

(No Model.)

2 Sheets—Sheet 1.

F. KROEBER.

APPARATUS FOR ADJUSTING THE BEAT OF PENDULUM CLOCKS.

No. 526,399.

Patented Sept. 25, 1894.

Fig. 1.

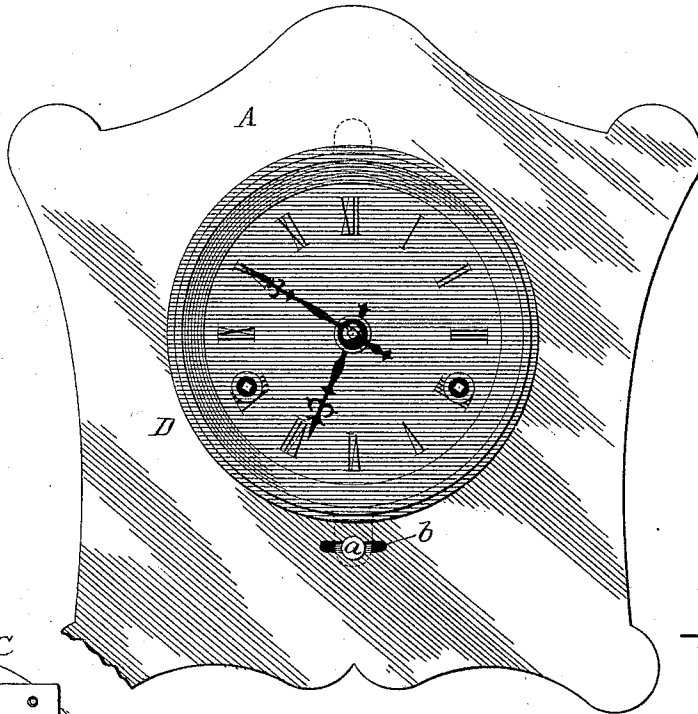

Fig. 2.

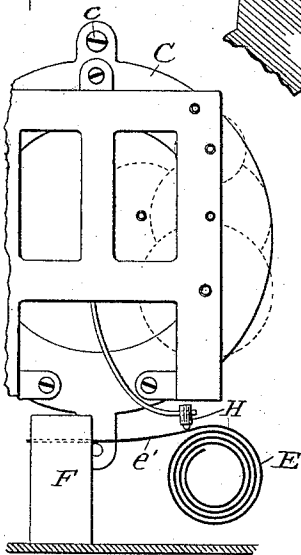

Fig. 4.

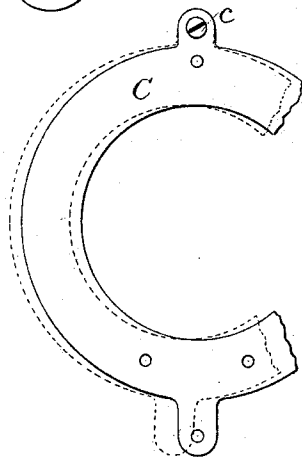
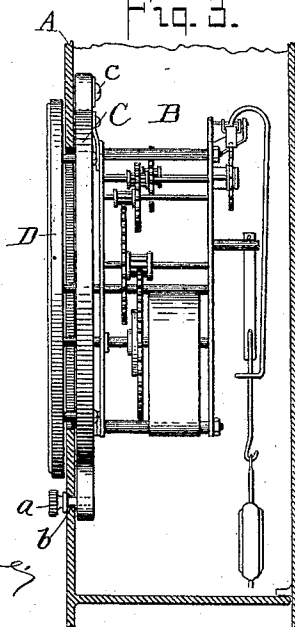

Fig. 3.



WITNESSES:

W. B. Shepard
Ed. C. Munsey

INVENTOR

Florence Kroeber

BY *Brisson & Knautz*

his ATTORNEYS

(No Model.)

2 Sheets—Sheet 2.

F. KROEBER.

APPARATUS FOR ADJUSTING THE BEAT OF PENDULUM CLOCKS.

No. 526,399.

Patented Sept. 25, 1894.

Fig. 5.

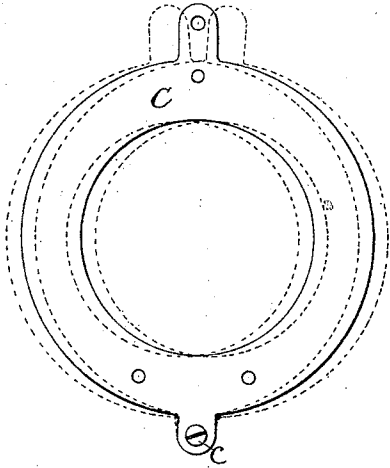

Fig. 6.

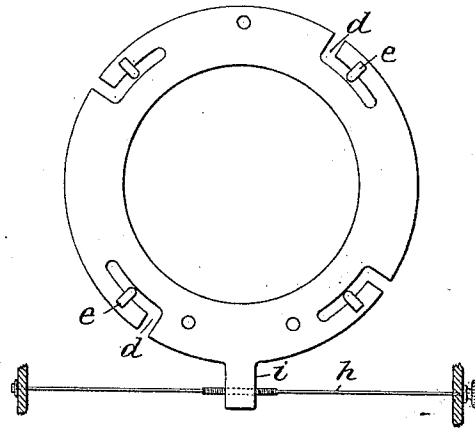

Fig. 7.

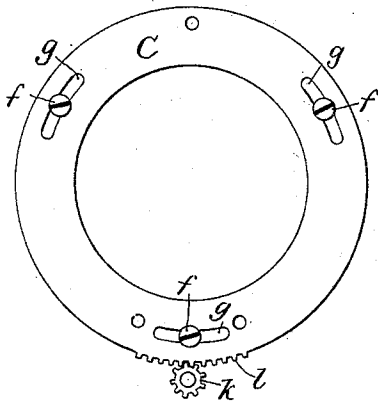
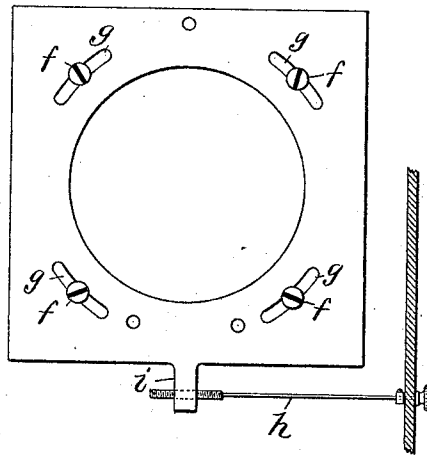

Fig. 8.



WITNESSES:

W. B. Shepherd.
Ed. C. Morse

INVENTOR

Florence Kroeber

BY *Brieser Knauth*

his ATTORNEYS

UNITED STATES PATENT OFFICE.

FLORENCE KROEBER, OF NEW YORK, N. Y.

APPARATUS FOR ADJUSTING THE BEAT OF PENDULUM CLOCKS.

SPECIFICATION forming part of Letters Patent No. 526,399, dated September 25, 1894.

Application filed April 19, 1894. Serial No. 508,123. (No model.)

To all whom it may concern:

Be it known that I, FLORENCE KROEBER, a resident of the city, county, and State of New York, have invented certain new and useful
5 Improvements in Clocks, of which the following is a specification.

My invention relates to clocks, and has for its object to produce a mantel pendulum clock that can be adjusted to the proper beat
10 without taking the case apart or adjusting by the crutch or escapement.

The primary use of the invention is to enable mantel clocks to be started and maintained in proper beat if placed on a mantel
15 which is not level or considerably out of plumb.

To this end my invention consists in fastening the movement and its dial and sash to a suitable supporting ring or plate and supporting this ring or plate movably upon some
20 portion of the clock case. Hitherto in clocks of this general character it has been customary to fasten the movement rigidly to the case and to fasten the dial rigidly upon the
25 front of the case or the movement has been attached and held to the clock case by the sash and dial. In these clocks as hitherto constructed it has been necessary, when the same have been placed upon a mantel or other support
30 which was out of plumb, to adjust the same to proper beat by leveling up the clock by means of shims or wedges or by taking the cases apart and changing the position of the movement in the case or by bending or
35 otherwise adjusting the crutch or escapement. Now, by my invention I obviate all these difficulties.

I attain the object of my invention by means of the mechanism illustrated in the
40 accompanying drawings, wherein—

Figure 1 is a face view of a mantel clock showing one form of my invention applied thereto. Fig. 2 is a broken away rear elevation of the movement and the supporting
45 ring or frame therefor. Fig. 3 is a side elevation partly in section of the mechanism illustrated in Figs. 1 and 2. Fig. 4 is a broken away detail view of one form of supporting ring or frame. Fig. 5 is an isometric view of a modification thereof. Figs. 6, 7, and 8 are
50 isometric face views of modified forms of rings, frames or plates showing also various

means for supporting the same upon the clock case and for moving the same with relation thereto.

It is well-known that when a mantel pendulum clock is placed upon a support more or less out of plumb it will not beat with regularity and if the inclination of the mantel be considerable, will even stop. In order to
55 remedy these defects it is necessary that the clock or its movement should be rocked so that the pendulum shall hang vertically when at about the middle of its stroke. Instead of adjusting the clock, as before described, I
60 have found it advantageous to adjust the position of the movement to obtain the proper hang of the pendulum. This I accomplish by means of the following mechanism.

In the drawings, A is a clock case containing a suitable movement B, preferably a square Yankee movement, as shown. This movement is secured upon a suitable ring,
70 plate or frame C of which several forms are shown, which is suitably secured to or carried
75 by the clock case A and movable relatively thereto.

In Figs. 1 to 4 inclusive I have shown this ring as suspended at *c* from a pivot. This ring also serves to support the sash and dial
80 D of the clock and to carry the same in its movement so that the position of the key-holes relatively to the key-posts will not be disturbed and the sash and dial kept in their
85 proper relative positions.

In the form shown in Fig. 1 the adjustment of this ring relatively to the clock case is effected by means of a set-screw *a* projecting through a slot *b* in the clock case and entering
90 an aperture in the ring C. When the ring has been adjusted to the proper position the set-screw may be screwed down to hold the same in its adjusted position.

In my preferred form, as shown in Fig. 1, I pivot the ring preferably by suspending the
95 same from its pivot, although the pivoting can be at the lower side, as shown in Fig. 5, or even on the sides, if desired. This ring, plate or frame may also be held to the clock case so as to be movable thereon by means
100 of screws, clamps or bayonet lock or similar fastening.

In Fig. 6 I have shown the ring as attached to the clock case by means of a bayonet lock

consisting of the angular slit *d* and hook pin *e*, while in Figs. 7 and 8 I have shown this ring or plate as attached to the clock case by means of screws *f* working in slits *g*.

5 Different means for adjusting or moving the ring may be used to suit different conditions of practice. For instance, I may adjust the ring by means of a worm-shaft *h* working in some part of the ring, as for instance, 10 the lug *i*, as shown in Figs. 6 and 8, or I may adjust the ring by means of a pinion as *k* upon a suitable spindle and co-operating with teeth *l* upon some part of the ring, as shown in Fig. 7.

15 I do not limit myself to mounting this ring, plate or frame upon the inside of the clock case as the same may be readily mounted upon the outside, in which case it will probably take the form of an ornamental ring or 20 indeed to any specific location of the ring on the clock case.

Now, it is obvious that if the ordinary form of gong were used with this adjustable clock movement the hammer H carried by the clock 25 movement would not at all times be in position to properly strike the gong. To overcome this I provide a suitable gong as E suitably mounted, as for instance, upon a post F,

the same being the ordinary arrangement for cathedral gong, and I provide this gong with 30 a curved portion *e'* conforming to the arc or sweep of the hammer H around the center of movement of the movable ring. By this means, when the hammer is in its retracted 35 position, it will be at all times the same distance from the gong which is vital to produce uniform sound.

I will have it understood that I do not herein limit myself to the precise construction and arrangement of the parts herein 40 shown, as the form, construction and arrangement thereof may be greatly varied without departing from the spirit of my invention; but

What I claim, and desire to secure by Letters Patent, is— 45

The combination with a clock case, of a ring, plate or frame, adjustably mounted thereon and adapted to be moved relatively thereto together with a clock movement and sash and dial carried by the ring, plate or frame substantially as described. 50

FLORENCE KROEBER.

Witnesses:

O. BARTEL,

W. VON SCHLEPEGRELL.