

(19) **DANMARK**

(10) **DK/EP 2808545 T3**



(12)

Oversættelse af  
europæisk patentskrift

Patent- og  
Varemærkestyrelsen

- 
- (51) Int.Cl.: **F 03 D 13/10 (2016.01)** **F 03 D 15/00 (2016.01)**
- (45) Oversættelsen bekendtgjort den: **2016-10-03**
- (80) Dato for Den Europæiske Patentmyndigheds bekendtgørelse om meddelelse af patentet: **2016-06-29**
- (86) Europæisk ansøgning nr.: **13169501.7**
- (86) Europæisk indleveringsdag: **2013-05-28**
- (87) Den europæiske ansøgnings publiceringsdag: **2014-12-03**
- (84) Designerede stater: **AL AT BE BG CH CY CZ DE DK EE ES FI FR GB GR HR HU IE IS IT LI LT LU LV MC MK MT NL NO PL PT RO RS SE SI SK SM TR**
- (73) Patenthaver: **Siemens Aktiengesellschaft, Wittelsbacherplatz 2, 80333 München, Tyskland**
- (72) Opfinder: **Ebbesen, Henning, Gåsdalvej 23, 6900 Skjern, Danmark**  
**Shukla, Akhilesh, Stationsvej 9, 2TH, 7330 Brande, Danmark**
- (74) Fuldmægtig i Danmark: **Zacco Denmark A/S, Arne Jacobsens Allé 15, 2300 København S, Danmark**
- (54) Benævnelse: **Vindmølleflangeforbindelse**
- (56) Fremdragne publikationer:  
**WO-A1-2013/042294**  
**US-A1- 2011 250 077**  
**US-A1- 2011 293 357**  
**US-A1- 2012 183 403**



## **DESCRIPTION**

**[0001]** The present invention relates to a wind turbine flange connection between the hub and the nacelle of the wind turbine, a wind turbine, a wind turbine hub and a wind turbine nacelle.

**[0002]** A wind turbine comprises a rotor with rotor blades and a hub. The hub of the wind turbine is connected to the nacelle of the wind turbine. The hub is connected to the main shaft of the wind turbine or to the rotor of an electrical generator at a direct driven wind turbine.

**[0003]** The hub is attached to the nacelle by a flange connection. The flange connection between the hub of a wind turbine and the nacelle comprises a flange at the hub of the wind turbine and a flange at the nacelle of the wind turbine

**[0004]** The hub sided flange and the nacelle sided flange are connected together by bolts. The bolts press the flanges together to prevent any movement of one of the flanges in relation to the other flange.

**[0005]** Document US2011/250077 discloses a prior art system according to the preamble of claim 1.

**[0006]** During the operation of the wind turbine the wind interacts with the rotor blades of the wind turbine and rotates the rotor. Due to the wind and gusts in the wind varying loads and vibrations are induced into the rotor.

**[0007]** The flange connection transfers the rotation to the main shaft of the wind turbine or to the rotor of the electrical generator. In addition radial forces, axial forces and bending moments from the loads and vibrations are transferred from the hub to the nacelle.

**[0008]** As the development of the wind turbine advances to bigger rotor diameters, more and more loads and vibrations have to be transferred over the flange connection.

**[0009]** It is known to increase the number and diameter of the bolts in the flange connection to prevent movements between the two flanges.

**[0010]** This shows the disadvantage, that more and heavier bolts are needed in a wind turbine and more installation time is needed for tightening the bolts.

**[0011]** Therefore, it is a first objective of the present invention to provide an advantageous wind turbine blade bearing. It is a second objective to provide an advantageous wind turbine hub and nacelle. A third objective of the present invention is to provide an advantageous wind turbine.

**[0012]** The aim of the invention is therefore to provide an improved flange connection between the hub and the nacelle of a wind turbine.

**[0013]** The object of the invention is achieved by the independent claims 1, 14 and 15. Further features of the invention are disclosed in the dependant claims.

**[0014]** A wind turbine flange connection between a hub and a nacelle is disclosed. The hub of the wind turbine comprises a first flange and the nacelle of the wind turbine comprises a second flange.

**[0015]** The first flange and the second flange are connected to each other by a number of connection means, to transfer forces between the first flange and the second flange.

**[0016]** The first flange comprises a plurality of holes and the second flange comprises a plurality of holes corresponding to the holes in the first flange. Shear pins are arranged in the holes in the flanges to transfer rotational forces between the hub and the nacelle.

**[0017]** The hub of a wind turbine is connected to a nacelle by a flange connection. The flange of the hub and the flange of the nacelle are connected by a number of connection means. The connection means can be bolts going through holes in the flanges of the hub and the nacelle.

[0018] Rotor blades are connected to the hub of the wind turbine. During the operation of the wind turbine the wind interacts with the rotor blades and rotates the hub.

[0019] The rotation is transferred over the flange connection to the nacelle. Thus, axial forces, rotational forces and tilting moments are transferred from the hub to the nacelle.

[0020] The connection means press the flanges of the hub and the nacelle together so that a transfer of the forces is possible.

[0021] The first flange of the hub comprises a plurality of holes and a second flange of the nacelle comprises a plurality of holes corresponding to the holes of the first flange. The holes in the first flange and the holes in the second flange are arranged in a way that they correspond to each other when the flanges are connected.

[0022] Shear pins are arranged in the holes of the flanges to transfer rotational forces between the hub and the nacelle. The shear pins are arranged in the holes of the flanges in addition to the connection means.

[0023] The shear pins take shear forces, thus rotational forces can be transferred from the first flange to the second flange. Thus, the ability of the flange connection to transfer rotational forces is improved. Thus, higher rotational forces can be transferred over the flange connection. Thus, higher loads can be transferred over the flange connection. Thus, more rotational energy can be transferred from the rotor of the wind turbine to the generator of the wind turbine in the nacelle.

[0024] Thus, more electrical energy is produced in the wind turbine. More rotational energy can be transferred over the flange connection without increasing the size and thereby the mass of the flanges.

[0025] The holes in the first flange and/or the holes in the second flange to accommodate the shear pins are blind holes.

[0026] The shear pins are arranged in the holes in the first flange and/or the holes of the second flange before the first flange and the second flange are connected. The shear pins can't accidentally be pushed out of the holes during the operation of connecting the flanges.

[0027] Thus, the shear pins are fixed in their position during the connection and during the operation of the wind turbine.

[0028] In addition, the shear pins can be used as guiding means to assist during the operation of connecting the flanges. Thus, the first flange is guided along the shear pins in the holes to a suitable position in reference to the second flange, while the hub of the wind turbine is connected to the nacelle of the wind turbine. Thus, the shear pins facilitate as guiding means in addition. Thus, the installation of the hub of the wind turbine can be performed easier and quicker.

[0029] The shear pins are at least arranged in a sector along the first flange where the hub shows a lower stiffness or a high gradient in the stiffness.

[0030] The hub of a wind turbine shows a changing stiffness along the first flange due to the constructive form of the hub. Thus, the first flange shows higher and lower values of stiffness along its surface. Thus, sectors of lower stiffness or sectors of a high gradient in the stiffness occur along the first flange.

[0031] The shear pins are arranged in a sector along the first flange where the first flange shows a lower stiffness or higher gradient in the stiffness.

[0032] The shear pins assist to transfer rotational forces from the first flange to the second flange in a sector of a lower stiffness or a high gradient in the stiffness.

[0033] Thus, the ability of the sector with a lower stiffness or a high gradient in the stiffness to transfer forces over the flange connection is increased.

[0034] The hub comprises a connection area that is prepared to receive a rotor blade and the shear pins are arranged in a sector along the first flange close to the area for the connection of a rotor blade.

[0035] Rotor blades are connected to the hub of a wind turbine. Thus, the hub of the wind turbine comprises a connection area that is prepared to receive a rotor blade.

[0036] During the operation of the wind turbine, the wind interacts with the rotor blades and induces forces into the rotor blades. The forces are transferred to the hub of the wind turbine via the connection area. The hub of the wind turbine rotates due to the forces induced in the rotor blades.

[0037] The forces induced in the rotor blades are transferred via the hub to the nacelle of the wind turbine. The loads and forces to be transferred over the flange connection are not evenly distributed along the flanges. In the sector along the first flange that is close to the area for the connection of the rotor blades higher forces and loads have to be transferred.

[0038] The shear pins are arranged in a sector along the first flange close to the area of the connection of the rotor blades. Thus, the shear pins are arranged in a sector where higher forces and loads have to be transferred.

[0039] Thus, the shear pins assist to transfer higher forces and loads over the flange connection. Thus, higher forces and loads can be transferred over the flange connection without increasing the size of the flange connection and thereby the mass of the flanges.

[0040] The hub comprises an opening for service and maintenance purpose and the shear pins are arranged in a sector along the first flange close to the area of the opening.

[0041] The hub comprises an opening for service and maintenance purpose. This can be man-holes, to allow service personal to reach the outer surface of the hub from the inside of the hub. Or this can be openings in the connection area to connect the rotor blades to the hub that are used to reach the interior of the rotor blades.

[0042] Openings in the hub for service and maintenance purpose are through-going holes through the wall of the hub. Through-going holes through the wall of the hub influence the stiffness of the hub. Thus, openings for service and maintenance purpose in the hub influence the stiffness along the first flange.

[0043] Thus openings in the hub lead to a changing stiffness along the first flange or to a high gradient of the stiffness along the first flange. The shear pins are arranged in a sector along the first flange close to the area of the opening.

[0044] Thus the shear pins transfer rotational forces over the flange connection in the area of the opening. Thus the ability of the flange connection to transfer rotational forces in a sector close to the area of an opening is improved.

[0045] The shear pins are arranged in the area of the first flange adjacent to a man-hole in the hub.

[0046] A man-hole is a through-going opening in the wall of the hub that allows service personal to reach from the inside of the hub to the outside. Through-going holes in the wall of the hub lead to a lower stiffness or a high gradient in the stiffness of the hub in the area of the opening.

[0047] The shear pins improve the transfer of rotational forces over the flange connection. The shear pins are arranged in the area of the first flange adjacent to a man-hole in the hub.

[0048] Thus the shear pins assist to transfer rotational forces in an area of lower stiffness or high gradient in the stiffness along the first flange of the flange connection.

[0049] The shear pins are located in three sectors along the circumference of the first flange which each cover up to one sixth of the circumference of the first flange.

[0050] Most of today's wind turbines are equipped with three rotor blades. This leads to three areas to connect a rotor blade at the hub. Close to the area for connection of a rotor blade, the first flange of the hub shows a lower stiffness or a high gradient in the stiffness.

[0051] The shear pins transfer rotational forces over the flange connection from the first flange to the second flange. The shear pins are arranged in a sector along the first flange close to the area for the connection of the rotor blades.

[0052] Thus the shear pins are arranged in three sectors along the circumference of the first flange. Each of the sectors along the first flange covers up to one sixth of the circumference of the first flange.

[0053] Thus the sector of lower stiffness or a high gradient in the stiffness is covered. Thus the distribution of the shear pins is optimized.

[0054] The plurality of shear pins is mainly evenly distributed along the circumference of the first flange.

[0055] The shear pins transfer rotational forces from the first flange to the second flange. Thus the rotational forces are mainly evenly transferred from the first flange to the second flange along the circumference of the flange connection.

[0056] The flange connection comprises a circle of holes that are arranged and prepared in a way to receive the connection means and the shear pins are arranged radially outward of the circle of holes.

[0057] The first flange and the second flange of the flange connection are connected by connection means. Preferably bolts are used as connection means. The bolts are arranged in holes in the first flange and the second flange.

[0058] The holes for the connection means are mainly evenly distributed along a circle in the first flange and the second flange for an even transfer of the axial forces, the rotational forces and the tilting moments over the flange connection.

[0059] Thus the holes for the connection means forms a circle of holes in the surface of the first flange and the second flange. The holes for the shear pins are arranged radially outward of the circle of holes of the connection means.

[0060] Thus the circle of holes for the shear pins show a larger radius than the circle of holes for the connection means. The bigger radius of the circle of holes of the shear pins leads to a longer lever for the shear pins to transfer rotational forces from the first flange to the second flange.

[0061] Thus the transfer forces by the shear pins is optimized.

[0062] The flange connection comprises a circle of holes that are arranged and prepared in a way to receive the connection means and that the shear pins are arranged radially inward of the circle of holes.

[0063] The first flange and the second flange of the flange connection are connected by connection means. Preferably bolts are used as connection means. The bolts are arranged in holes in the first flange and the second flange. The holes for the connection means are mainly evenly distributed along a circle in the first flange and the second flange for an even transfer of the axial forces, the rotational forces and the tilting moments over the flange connection.

[0064] Thus the holes for the connection means form a circle of holes in the surface of the first flange and the second flange.

[0065] The holes for the shear pins are arranged radially inward of the circle of holes of the connection means.

[0066] Thus the circle of holes for the shear pins show a smaller radius than the circle of holes for the connection means.

[0067] Thus the shear pins are located in an area of the surface of the flange connection where fewer forces are present. Thus the area of the surface with fewer forces is penetrated by the holes for the shear pins.

[0068] In addition, the shear pins can be arranged in two circles. A first circle is arranged radially outwardly of the circle of holes for the connection means. The second circle is arranged radially inwardly of the circle of holes for the connection means.

[0069] Thus the holes for the connection means and the holes for the shear pins are more evenly distributed in the area of the surface of the flange connection. Thus there are no spots with a high density of holes in the surface of the flange.

[0070] Thus the flange connection shows a more even distribution of material and therefore a more even ability to transfer forces.

[0071] Thus no weak areas, with a high density of holes, are present along the surface of the flange that might experience fatigue damages due to constant changing forces induced by the wind during operation of the wind turbine.

[0072] The flange connection comprises a circle of holes that are arranged and prepared in a way to receive the connection means and that the shear pins are arranged between the holes.

[0073] Thus the holes for the shear pins are arranged in a circle of holes with the same diameter than the circle of holes for the connection means.

[0074] Thus the width of the surface of the first flange and the second flange can be optimized.

[0075] The connection means are bolts.

[0076] Preferably bolts are used to connect the first flange and the second flange in the flange connection.

[0077] A wind turbine comprises a flange connection as disclosed.

[0078] A hub of a wind turbine comprises a flange that is prepared and arranged in a way to be connected to a nacelle of a wind turbine. The flange comprises a plurality of first holes that are prepared and arranged in a way to interact with connection means be used to connect a hub to the nacelle.

[0079] The flange comprises a plurality of second holes that are prepared and arranged in a way to contain shear pins, to be used to transfer rotational forces from the hub to the nacelle when the hub is connected to the nacelle.

[0080] The shear pins assist to transfer rotational forces from the hub to the nacelle when the hub is connected to the nacelle.

[0081] Thus the transfer of rotational forces from the hub to the nacelle is optimized.

[0082] A nacelle of a wind turbine comprises a flange that is prepared and arranged in a way to be connected to a hub of a wind turbine.

[0083] The flange comprises a plurality of first holes that are prepared and arranged in a way to interact with connection means being used to connect the nacelle to the hub. The flange comprises a plurality of second holes that are prepared and arranged in a way to interact with shear pins to be used to transfer rotational forces from the hub to the nacelle, when the nacelle is connected to the hub.

[0084] During the operation of the wind turbine axial forces, rotational forces and tilting moments are transferred from the hub of the wind turbine to the nacelle.

[0085] The shear pins assist to transfer rotational forces from the hub to the nacelle.

[0086] Thus the shear pins support the transfer of rotational forces. Thus the transfer of rotational forces is optimized.

[0087] The invention is shown in more detail by the help of figures. The figures show a preferred configuration and do not limit the scope of the invention.

FIG 1 shows a hub of a wind turbine,

FIG 2 shows a detail of the hub,

FIG 3 shows another embodiment of the hub,

FIG 4 shows a cut through a hub,

FIG 5 shows a detail of a flange connection,

FIG 6 shows a flange of the prior art.

[0088] FIG 1 shows a hub of a wind turbine.

[0089] FIG 1 shows a hub 1 of a wind turbine. The hub 1 comprises a flange 2 that is used to connect the hub 1 to the nacelle.

[0090] The flange 2 comprises holes 13. The holes 13 are used with connection means 4 like bolts to connect the hub 1 to the nacelle. The flange 2 comprises holes 5 for shear pins 7. The hub 1 comprises connection areas 8 to connect rotor blades to the

hub 1.

**[0091]** The wind interacts with the rotor blades and causes a rotation of the hub 1. The rotation of the hub 1 is transferred via the flange connection to the nacelle. Thus axial forces, rotational forces, and tilting moments are transferred over the flange connection.

**[0092]** The shear pins 7 are arranged in the holes 5 of the flange 2. The shear pins 7 transfer rotational forces from the first flange 2 of the hub 1 to the second flange 3 of the nacelle.

**[0093]** The hub 1 comprises man holes 12 for maintenance service. The hub 1 shows a lower stiffness, or high gradient in the stiffness, close to the connection areas 8 or the man holes 12.

**[0094]** In figure 1, the holes 5 for the shear pins 7 are arranged in three sectors 9, 10, 11 along the first flange 2 close to the area 8 for the connection of the rotor blade. Thus the shear pins 7 are arranged in an area with a lower stiffness of the hub 1.

**[0095]** Figure 2 shows a detail of the hub.

**[0096]** Figure 2 shows a detail of the hub 1. The hub 1 comprises a connection area 8 to connect a rotor blade to the hub 1. The hub 1 comprises a first flange 2 to connect the hub 1 to a nacelle.

**[0097]** The first flange 2 comprises holes 13 to be used by bolts 4. The first flange 2 comprises holes 5 to be used with shear pins 7. The holes 5 are arranged in a sector 9 that is close to the connection area 8 for connecting the rotor blade to the hub 1.

**[0098]** The holes 13 along the first flange 2 are arranged as a circle of holes. The holes 5 are arranged between the holes 13.

**[0099]** Figure 3 shows another embodiment of the hub.

**[0100]** Figure 3 shows another embodiment of the hub 1. The hub 1 comprises a connection area 8 to connect a rotor blade to the hub 1. The hub 1 comprises a first flange 2 to connect the hub to a nacelle of a wind turbine. The first flange 2 comprises a circle of holes 13. The holes 13 are used with bolts 4 to connect the hub 1 of the wind turbine to the nacelle. The first flange 2 comprises holes 5 to be used with shear pins 7.

**[0101]** The holes 5 are arranged in a sector 9 that is closed to the connection area 8 to connect a rotor blade to the hub 1. The holes 13 are arranged in a circle along the surface of the first flange 2. The holes 5 are arranged in the surface of the first flange 2 radially outward of the circle of holes 13.

**[0102]** Figure 4 shows a cut through a hub.

**[0103]** Figure 4 shows a cut through a hub 1. The hub 1 comprises a connection area 8 to connect a rotor blade to the hub. The hub 1 comprises a first flange 2 to connect the hub 1 to the nacelle. The nacelle comprises a second flange 3 that is connected to the first flange 2 by bolts 4.

**[0104]** Figure 5 shows a detail of a flange connection.

**[0105]** Figure 5 shows a detail of a flange connection according to figure 4. A hub 1 comprises a connection area 8 to connect a rotor blade to the hub 1.

**[0106]** The hub 1 comprises a first flange 2 to connect to a second flange 3, of a nacelle. The first flange 2 and the second flange 3 are connected by bolts 4.

**[0107]** The first flange 2 comprises holes 5. The second flange 3 comprises holes 6. The holes 5, 6 are blind holes. The blind holes 5, 6 comprise a shear pin 7.

**[0108]** The wind interacts with a rotor blade and rotates the hub 1. The rotation of the hub 1 is transferred via the flange connection of the first flange 2 and a second flange 3 to the nacelle of the wind turbine. The flange connection transfers axial forces, radial forces and tilting moments from the hub 1 to the nacelle. The shear pins 7 transfer rotational forces from the hub 1 to the nacelle.

[0109] Figure 6 shows a flange of the prior art.

[0110] Figure 6 shows a flange of a hub 1 of the prior art. The hub 1 comprises three connection areas 8 to connect rotor blades to the hub. The hub 1 comprises a flange 2 to connect a hub 1 to a nacelle. A flange 2 comprises a circle of holes 13 that are used to connect the hub 1 to the nacelle with bolts.

[0111] The wind interacts with the rotor blades and rotates the hub 1. The rotation is transferred from the hub 1 to the nacelle. The bolts through the holes 13 transfer axial forces, radial forces and tilting moments from the hub 1 to the nacelle.

[0112] The illustration in the drawings is in schematic form. It is noted that in different figures, similar or identical elements are provided with the same reference signs.

[0113] Although the present invention has been described in detail with reference to the preferred embodiment, it is to be understood that the present invention is not limited by the disclosed examples, and that numerous additional modifications and variations could be made thereto by a person skilled in the art without departing from the scope of the invention.

[0114] It should be noted that the use of "a" or "an" throughout this application does not exclude a plurality, and "comprising" does not exclude other steps or elements. Also elements described in association with different embodiments may be combined. It should also be noted that reference signs in the claims should not be construed as limiting the scope of the claims.

## **REFERENCES CITED IN THE DESCRIPTION**

This list of references cited by the applicant is for the reader's convenience only. It does not form part of the European patent document. Even though great care has been taken in compiling the references, errors or omissions cannot be excluded and the EPO disclaims all liability in this regard.

### **Patent documents cited in the description**

- [US2011250077A \[0005\]](#)

## Patentkrav

1. Vindmølleflangeforbindelse mellem et nav (1) og en nacelle,  
- hvor navet (1) af vindmøllen omfatter en første flange (2),  
5 - hvor nacellen af vindmøllen omfatter en anden flange (3),  
- hvor den første flange (2) og den anden flange (3) er forbundet med hinanden med et antal forbindelsesmidler (4) til overførsel af kræfter mellem den første flange (2) og den anden flange (3),  
- den første flange (2) omfatter en flerhed af huller (5), og den anden flange  
10 (3) omfatter en flerhed af huller (6), der svarer til hullerne (5) i den første flange (2),  
- hvor brudstifter (7) er anbragt i hullerne (5, 6) af flangerne (2, 3) til overførsel af rotationskræfter mellem navet (1) og nacellen,  
**kendetegnet ved, at**  
15 - brudstifterne (7) er anbragt ud over forbindelsesmidlerne (4) og mindst i en sektor (9, 10, 11) langs den første flange (2), hvor navet (1) udviser en lavere stivhed eller en høj gradient i stivheden.
2. Vindmølleflangeforbindelse ifølge krav 1, **kendetegnet ved, at** hullerne (5)  
20 i den første flange (2) og/eller hullerne (6) i den anden flange (3) til indsætning af brudstifterne (7) er blindhuller.
3. Vindmølleflangeforbindelse ifølge et af de foregående krav, **kendetegnet ved, at** navet (1) omfatter et forbindelsesområde (8), der er indrettet til at  
25 modtage en rotorvinge, og at brudstifterne (7) er anbragt i en sektor (9, 10, 11) langs den første flange (2) tæt på området (8) til forbindelse af en rotorvinge.
4. Vindmølleflangeforbindelse ifølge et af de foregående krav, **kendetegnet ved, at** navet (1) omfatter en åbning (12) til service- og vedligeholdelsesformål, og at brudstifterne (7) er anbragt i en sektor langs den første flange (2)  
30 tæt på åbningens (12) område.
5. Vindmølleflangeforbindelse ifølge et af de foregående krav, **kendetegnet ved, at** brudstifterne (7) er anbragt i området af den første flange (2) i umid-  
35

delbar nærhed af et mandehul (12) i navet.

5 **6.** Vindmølleflangeforbindelse ifølge et af de foregående krav, **kendetegnet ved, at** brudstifterne (7) er anbragt i tre sektorer (9, 10, 11) langs omkredsen af den første flange (2), som hver dækker op til en sjettedel af omkredsen af den første flange (2).

10 **7.** Vindmølleflangeforbindelse ifølge et af de foregående krav, **kendetegnet ved, at** flerheden af brudstifter (7) hovedsageligt er jævnt fordelt langs omkredsen af den første flange (2).

15 **8.** Vindmølleflangeforbindelse ifølge et af de foregående krav, **kendetegnet ved, at** flangeforbindelsen omfatter en cirkel af huller (13), der er anbragt og indrettet således, at de modtager forbindelsesmidlerne (4), og ved at brudstifterne (7) er anbragt udvendigt i radial retning i forhold til cirklen af huller (13).

20 **9.** Vindmølleflangeforbindelse ifølge et af de foregående krav, **kendetegnet ved, at** flangeforbindelsen omfatter en cirkel af huller (13), der er anbragt og indrettet således, at de modtager forbindelsesmidlerne (4), og ved at brudstifterne (7) er anbragt indvendigt i radial retning i forhold til cirklen af huller (13).

25 **10.** Vindmølleflangeforbindelse ifølge et af kravene 1 til 7, **kendetegnet ved, at** flangeforbindelsen omfatter en cirkel af huller (13), der er anbragt og indrettet således, at de modtager forbindelsesmidlerne (4), og ved at brudstifterne (7) er anbragt mellem hullerne (13).

**11.** Vindmølleflangeforbindelse ifølge et af de foregående krav, **kendetegnet ved, at** forbindelsesmidlerne (4) er bolte.

30 **12.** Vindmølle omfattende en flangeforbindelse ifølge et af kravene 1 til 12.

**13.** Nav (1) af en vindmølle til anvendelse i en flangeforbindelse ifølge et af kravene 1 til 12.

35 **14.** Nacelle af en vindmølle til anvendelse i en flangeforbindelse ifølge et af kravene 1 til 12.

DRAWINGS

FIG 1

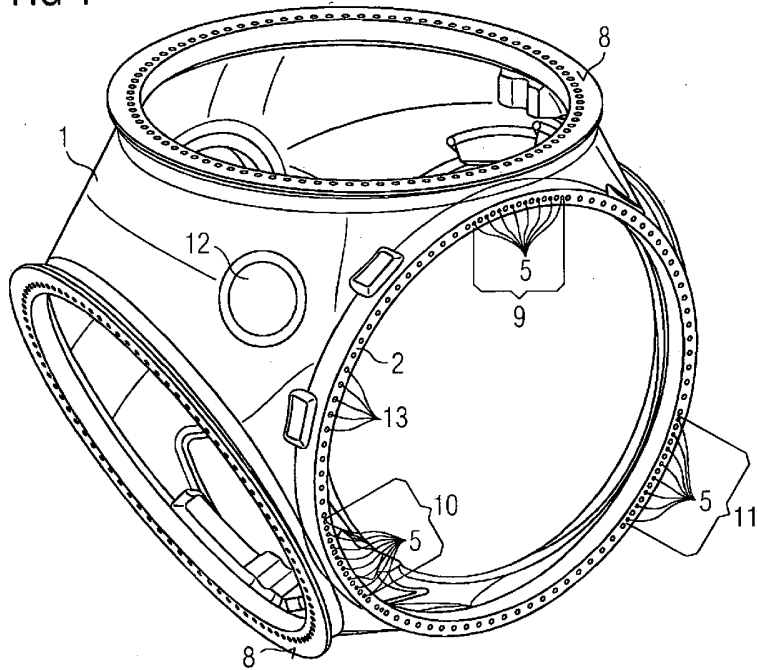

FIG 2

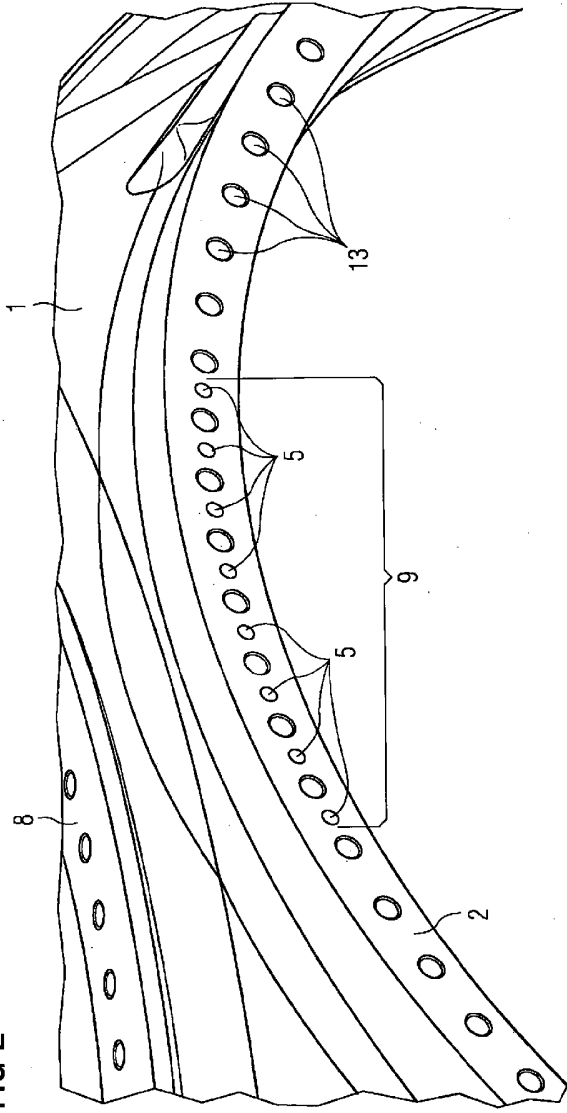

FIG 3

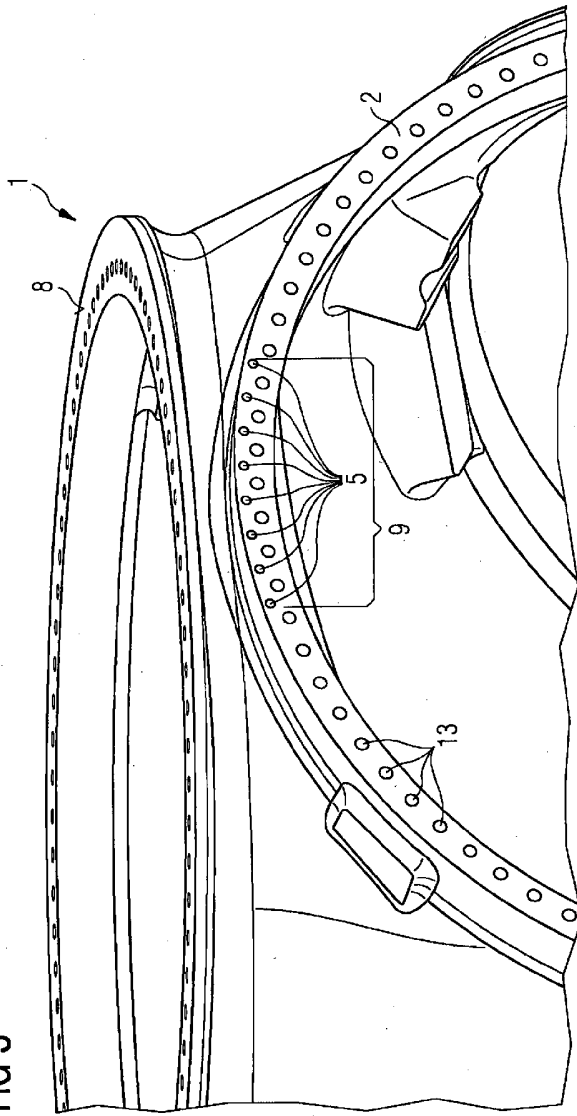

FIG 4

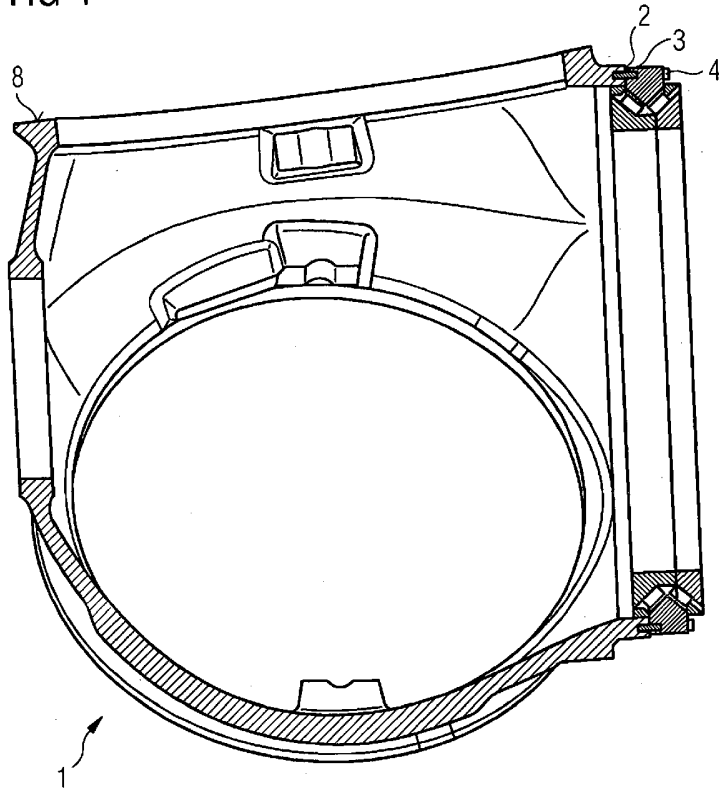



FIG 6

