

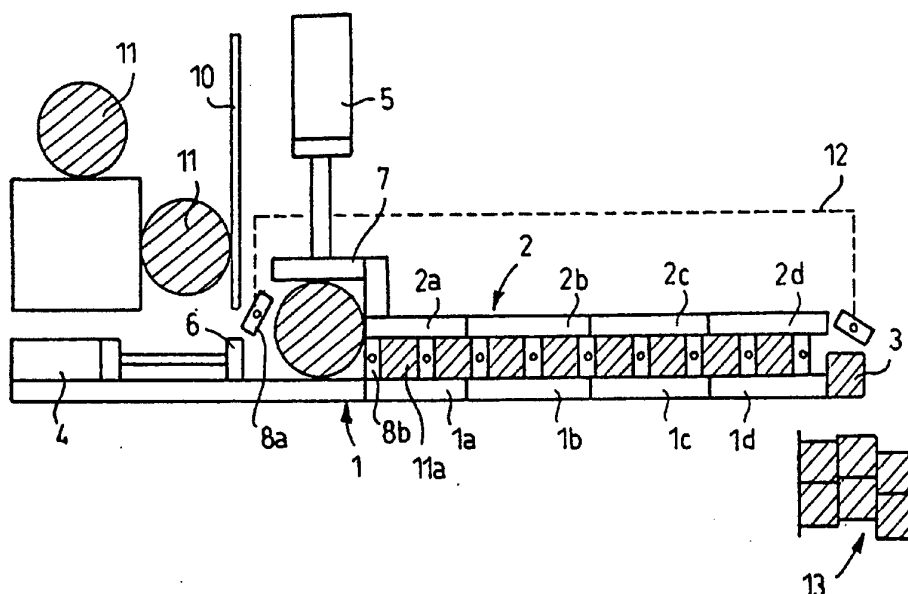

INTERNATIONAL APPLICATION PUBLISHED UNDER THE PATENT COOPERATION TREATY (PCT)

| | | |
|---|--|---|
| <p>(51) International Patent Classification ⁵ : B27M 1/02</p> | <p>A1</p> | <p>(11) International Publication Number: WO 94/20273 (43) International Publication Date: 15 September 1994 (15.09.94)</p> |
| <p>(21) International Application Number: PCT/FI94/00088 (22) International Filing Date: 10 March 1994 (10.03.94) (30) Priority Data: 931077 10 March 1993 (10.03.93) FI 931078 10 March 1993 (10.03.93) FI (71)(72) Applicant and Inventor: KAUSE, Jaakko [FI/FI]; Turajärvi, FIN-27510 Eura (FI). (74) Agent: OY KOLSTER AB; Iso Roobertinkatu 23, P.O. Box 148, FIN-00121 Helsinki (FI).</p> | <p>(81) Designated States: AT, AU, BB, BG, BR, BY, CA, CH, CN, CZ, DE, DK, ES, FI, GB, GE, HU, JP, KP, KR, KZ, LK, LU, LV, MG, MN, MW, NL, NO, NZ, PL, PT, RO, RU, SD, SE, SI, SK, TT, UA, US, UZ, VN, European patent (AT, BE, CH, DE, DK, ES, FR, GB, GR, IE, IT, LU, MC, NL, PT, SE), OAPI patent (BF, BJ, CF, CG, CI, CM, GA, GN, ML, MR, NE, SN, TD, TG).</p> <p>Published <i>With international search report. In English translation (filed in Finnish).</i></p> | |

(54) Title: METHOD FOR MAKING HARD-PRESSED WOOD



(57) Abstract

A method for making hard-pressed wood by compressing a piece of wood to a volume smaller than its original volume. A piece of wood (11; 11a) sufficiently moist or even saturated with water is compressed preferably at room temperature in a direction transverse to the fibres by a relatively rapid compression motion so that substantially the same pressure exists in the transverse direction of the whole compressible piece of wood (11; 11a), whereby water is removed from the faces of the piece of wood (11; 11a) when the compression continues. After having been compressed to its final size, the piece of wood (11; 11a) is kept in the achieved compression volume and heated as a whole so that the materials therein plasticizing under the influence of heat bind the remaining wood material to an integral material, after which the wood still being in its compressed volume is cooled so that the wood solidifies permanently in its compressed form.

FOR THE PURPOSES OF INFORMATION ONLY

Codes used to identify States party to the PCT on the front pages of pamphlets publishing international applications under the PCT.

| | | | | | |
|----|--------------------------|----|--|----|--------------------------|
| AT | Austria | GB | United Kingdom | MR | Mauritania |
| AU | Australia | GE | Georgia | MW | Malawi |
| BB | Barbados | GN | Guinea | NE | Niger |
| BE | Belgium | GR | Greece | NL | Netherlands |
| BF | Burkina Faso | HU | Hungary | NO | Norway |
| BG | Bulgaria | IE | Ireland | NZ | New Zealand |
| BJ | Benin | IT | Italy | PL | Poland |
| BR | Brazil | JP | Japan | PT | Portugal |
| BY | Belarus | KE | Kenya | RO | Romania |
| CA | Canada | KG | Kyrgyzstan | RU | Russian Federation |
| CF | Central African Republic | KP | Democratic People's Republic of Korea | SD | Sudan |
| CG | Congo | KR | Republic of Korea | SE | Sweden |
| CH | Switzerland | KZ | Kazakhstan | SI | Slovenia |
| CI | Côte d'Ivoire | LI | Liechtenstein | SK | Slovakia |
| CM | Cameroon | LV | Latvia | SN | Senegal |
| CN | China | LU | Luxembourg | TD | Chad |
| CS | Czechoslovakia | MC | Monaco | TG | Togo |
| CZ | Czech Republic | MD | Republic of Moldova | TJ | Tajikistan |
| DE | Germany | MG | Madagascar | TT | Trinidad and Tobago |
| DK | Denmark | ML | Mali | UA | Ukraine |
| ES | Spain | MN | Mongolia | US | United States of America |
| FI | Finland | | | UZ | Uzbekistan |
| FR | France | | | VN | Viet Nam |
| GA | Gabon | | | | |

METHOD FOR MAKING HARD PRESSED WOOD

The invention relates to a method for making wood having at least hard-pressed surface, in which
5 method a piece of wood is compressed to a volume smaller than its original volume for increasing its density and hardness.

Attempts have been made to make wood harder and thus more suitable for many purposes requiring wear
10 resistance and strength by compressing it so that pores in the wood get blocked or smaller while the volume of the wood decreases. Attempts have also been made for producing hard wood by saturating the wood with various plastic materials or adhesives. Further,
15 efforts have been made to compress wood to different predetermined shapes for a manufacture of various products or product blanks, for instance.

For bringing wood into a compressible state, it has been heated either by evaporation, microwave radiation or in some other manner, and then, attempts
20 have been made to compress the hot wood. Likewise, efforts have been made to make wood compressible by various chemicals, such as ammonia. Such solutions are known e.g. from Finnish Patent 10 001, British
25 Patent 1 426 555 and U.S. Patent 4,606,388.

In the solution disclosed in Finnish Patent 10 011, moist or heated wood is compressed, and then the compressed wood is placed into a mould and hardened in moist hot steam, which makes the wood material swell. In a subsequent drying step, the wood
30 shrinks, respectively, when the moisture leaves the wood.

British Patent 1 426 555 discloses a solution, in which strips of wood or logs and adhesive are arranged in a mould, the intention being to press the
35

adhesive into the wood material at the same time as it remains between the logs or strips adhering them to each other. Wood material and wood blanks compressed to shape are provided by this solution, but
5 actual hard wood or wood having hard surface is not produced by means of this method, which additionally requires extra adhesive making it difficult to apply the method and increasing the costs.

U.S. Patent 4 606 388 describes a solution for
10 compressing wood to hard wood material by impregnating it at first with ammonia to plasticize it, after which the wood is compressed several sequential times to provide a compression. Additionally, the wood must be dried separately at a temperature of less than 100
15 °C to remove the remaining water, which makes an application more difficult and increases the costs. Also in this solution, it is necessary to use an extra additive, i.e. ammonia.

Moreover, U.S. Patent 4,469,156 discloses a so-
20 lution, in which wood saturated with water is heated by microwave radiation and bent or formed into a desired shape while the material is still hot. After the forming, a separate drying takes place, at which the moisture is removed from the wood. It is not the
25 purpose of the solution to produce hard wood, but only to shape it. Therefore, this invention has a purpose and a solution to a problem different from those of the present invention.

A weakness of the known solutions is that,
30 through them, it is not possible to make sufficiently hard wood, either because the centre of the wood produced does not become hard enough or because the hardness and density of the surface portions of the wood material are not sufficient or deep enough. Fur-
35 ther, by using them, it is not possible to produce

wood material of equal quality, in which the wood hardness at the surface would be sufficient so that profiles or wood products having complicated cross-sections and being ready-shaped for a purpose of use could be provided simultaneously. By means of the known solutions, it is not possible either to provide bodies being ready-calibrated for the purpose of use and having surfaces formed into various shapes, because, using these solutions, it is impossible to provide a sufficiently equal plasticization of the wood material before the compression step.

An object of the present invention is to provide such a method of making compressed wood by which is effected a desired hardness to the heart of the wood, if necessary, so that the wood can be equally durable and hard along its entire cross-section. A further object of this invention is to provide such a method of making compressed wood by which can be effected a desired compression of wood and compressed wood suitable for use as such, as far as its outer dimensions and cross-section are concerned, and dense and hard enough at its surface portions. The method of the invention is characterized in that a piece of wood containing at least a predetermined amount of moisture is compressed in a direction transverse to its wood fibres and that the volume of the compressed piece of wood to which it was initially compressed is substantially maintained and that, having said volume, the compressed piece of wood as a whole is heated to a temperature of over 100 °C so that the materials in the piece of wood plasticizing under the influence of heat can be made softer and to adhere to the remaining wood material, in which case the moisture contained in the wood provides, when evaporated, an equal pressure inside the piece of wood while the

steam leaves the wood under the influence of pressure, after which the piece of wood is cooled, which makes the soft materials solidify, and the piece of wood remains permanently in its compressed form and
5 volume.

An essential idea of the invention is that a sufficiently moist piece of wood preferably saturated with a liquid is compressed to a desired compression ratio, which preferably takes place as a relatively
10 rapid compression step, whereby substantially all the liquid can be removed from the piece of wood via the ends thereof. Simultaneously, the liquid contained in the wood provides an equal pressure in the whole piece of wood, which is a condition of that the compression can be accomplished equally through the
15 whole piece of wood to the heart thereof. A further essential idea of the invention is that the compression is preferably performed when the piece of wood is at normal ambient temperature and that the piece
20 of wood is heated after the compression, still under the influence of compression, substantially entirely to a high temperature so that lignins, resins and other heat-plasticized materials contained in the wood material bind the fibres of the piece of wood
25 tightly and densely together. Subsequently, the temperature is lowered and the piece of wood is not released from the compression until the temperature has sunk so low that the binding agents of the wood have solidified and thus solidified the piece of wood permanently in its compressed form. According to one
30 preferred embodiment of the invention, a piece of wood is compressed into a shape having predetermined cross-section and dimensions, whereby a surface layer of the piece of wood is densified as dense and hard
35 as desired, while the heart may be formed either

throughout hard or in a desired manner softer than the surface layer, depending on the purpose of use. Still according to another preferred embodiment of the invention, a piece of wood is heated before compression, for instance by conducting electric current through the piece of wood, through which the wood material can be heated securely and equally, while it can be heated up to 500 - 600 °C or even higher.

5
10
15
20
25
30
35

By means of the method of the invention, a preheating of wood material is avoided, if desired, because a compression, if performed rapidly enough, may be carried out by using wood at an ambient temperature above zero degrees. A further advantage of the solution according to the invention is that wood can be compressed up to a compression ratio 1:2,5 or more, due to which it will be really compact and dense, while its strength and smoothness are considerably better than those of the known solutions. Moreover, the method according to the invention can be applied to a manufacture of products from wood for various purposes and with various hardnesses and densities as well as shapes, while any tree species, including alder, aspen and other tree species considered as soft, may be used for the manufacture. In the method, round wood material or wood material roughly calibrated to various shapes may be used as the piece of wood to be compressed. Similarly, either rectangular, octagonal or round compressed hardwood pieces or hardwood pieces of nearly any shape can be produced by this method. Still an advantage of the method is that the wood obtained is throughout undamaged and free from colour defects, which is an absolute condition especially for visible surface materials. When preheating the piece of wood, the wood can be made throughout equally soft and thus easily compressible

and the compressible piece of wood can be curved or bent without breaking or fracturing when compressed, because it is elastic enough due to its softness. An additional advantage of the invention is that nearly
5 100 % of the wood material can be used for various purposes, while a final product is obtained, which has a dimensioning and shape just suitable for the purpose of use. Further, an advantage of the method according to the invention is that various recesses
10 and embeddings can be provided in the final product by suitably shaped jaws of a compressing equipment, for instance for fastening fittings and other accessories, due to which extra shapings or other working measures are not always needed. Especially for pur-
15 poses when a compact integral surface layer is needed, but a softer and less dense heart either for fastening or insulating reasons, it is possible to manufacture by the method of the invention pieces of wood of various kinds and shapes as well as with various
20 densities of the heart portion. A piece of wood manufactured according to the invention may also be coated or surface-treated in various manners known per se to achieve a desired appearance.

The invention will be described in more detail
25 in the attached drawings, in which

Figure 1 shows schematically a compressing equipment suitable for implementing the method of the invention,

Figure 2 shows schematically hardnesses of tree
30 species obtained by the method of the invention compared to the original hardness values thereof,

Figure 3 shows schematically hardnesses of wood compressed by the method of the invention compared to natural tree species known as hard,

35 Figure 4 shows schematically bending strengths

of wood materials compressed by the method of the invention compared to the natural values thereof,

Figure 5 shows a schematical block diagram of implementing a second embodiment of the method of the invention in steps,

Figure 6 shows schematically a side view of another compressing equipment suitable for implementing the method of the invention and

Figure 7 shows schematically a heating equipment, by which a compressible piece of wood can be preheated and the compressed piece of wood heated, respectively.

Figure 1 shows schematically a compressing equipment suitable for implementing the method of the invention, in which wood can be compressed continuously also without preheating the wood. The compressing equipment comprises a compression table 1, above which there is a cover part 2. These form between themselves a treating channel 3, through which a compressed piece of wood is led after the compression in order to be heated and cooled. The compressing equipment further comprises compression cylinders 4 and 5 mounted substantially perpendicularly to each other, the compression cylinder 4 being parallel to the compression table 1 and the compression cylinder 5 perpendicular thereto. To piston rods of the compression cylinders 4 and 5 are fastened compression plates 6 and 7, by means of which the piece of wood is compressed. Moreover, the compressing equipment comprises intermediate beams 8; 8a, 8b necessary in a continuous-action compressing equipment to keep the compressed piece of wood in its compressed shape during the time it is treated after the compression. For feeding pieces of wood, the compressing equipment further comprises a proportioning table 9 and a guide

plate 10 for raw wood.

According to the invention, a raw uncompressed piece of wood 11 having a moisture of at least about 12 %, but being preferably saturated with water in some situations, is fed between the proportioning table 9 and the guide plate 10 on the compression table 1, with the piston of the cylinder 4 retracted, whereby the piece of wood 11 falls in front of it. Then the piece of wood 11 is pushed to the right in the figure, until it is under the cylinder 5. Subsequently, an intermediate beam 8a is positioned between the piece of wood 11 and the compression plate 6 of the cylinder 4. At this stage, the piece of wood 11 is preferably at normal room temperature, i.e. at ambient temperature, and there is no need to warm or heat it up. Then the piece of wood 11 is compressed by means of the cylinders 4 and 5, due to which the liquid, mainly water, contained in the piece of wood 11 is squeezed out of the ends thereof, while substantially the same pressure prevails throughout the whole piece of wood 11. In this manner, it is possible to get out the liquid contained in the piece of wood and to make wood fibres mutually movable so that it is even possible to achieve the compression ratio 1:2,5, and accordingly, the wood material substantially emptied of water can be brought into a dense, compact and homogenic form. After the compression, the successive intermediate beams 8a and 8b are coupled to each other so that the compressed piece of wood 11 cannot expand substantially in the direction between the beams after the termination of the compression. When the intermediate beams 8a and 8b move to the right in the figure, the compressed piece of wood 11a moves with them into the treating channel 3 between the compression table 1 and the cover part 2,

in which channel it is heated at the same time as it maintains the volume to which it was initially compressed. The heating may take place in various manners, e.g. in a manner to be described later by conducting an electric current through the wood, the temperature preferably being about 500 to 600 °C. Then the compressed and heated piece of wood is allowed to cool e.g. by lowering stepwise the temperature of the compression table and the cover part in the direction of motion of the piece of wood, and subsequently, a final cooling is performed e.g. by means of a cooling part cooled with cold water and situated at the end of the compression table 1 and the cover part 2. This is illustrated schematically in Figure 1 by zones 1d and 2a to 2d indicated on the compression table 1 and the cover part 2, the zone 1a/2a being the hottest one and the temperature of the zone 1b/2b and 1c/2c sinking suitably by e.g. about 200 °C compared to the previous zone. The zone 1d/2d again is a cooling zone, which can be cooled with water, for instance. After the compressed piece of wood has passed through the treating channel 3, the intermediate beam on the right side thereof is released from the coupling to the intermediate beam on the left side thereof and the intermediate beam is recirculated to the compression end along a conveyor path 12 indicated by broken lines. Correspondingly, the compressed piece of wood in its final form falls into a receiving gap 13 or is forwarded in some other way known per se for further processing.

The treating channel may be adjusted for instance by means of an adjustable cover part, which means that for each treating channel 3 height must be used intermediate beams of the same height for maintaining the compressed piece of wood as desired dur-

ing the whole treatment. The intermediate beams 8 can be displaced from the end of the compressing equipment to the beginning thereof in many different ways by using equipments and methods known per se. The successive intermediate beams may be coupled after the compression step by using suitable coupling means. The compression cylinders 4 and 5 are preferably mounted in such a manner that they can be displaced in a direction transverse to their compression direction. The compression point of the cylinders may then be set to move according to the midpoint of the piece of wood 11 so that the compression takes place, when the piece of wood is compressed and the midpoint moves both horizontally and vertically, all the time directly towards the midpoint from both directions. The compressed piece of wood 11a can also be heated in different ways, as for instance by using a heated compression table and cover part, which heat the piece of wood starting from the surface. This is, however, a slow procedure and may also cause colour defects at the surface portion of the piece of wood, which is not appropriate for all purposes.

Hardness values measured for pieces of wood made by the method of the invention are shown by way of example in Figure 2 for various tree species compared to the original hardness values thereof. The hardness is shown in the figure measured across the grain, on the one hand, and along the grain, on the other hand. The hardness of the pieces of wood obtained by compression has increased considerably across the grain for all tree species, being nearly 3,5-fold at its best. The hardness along the grain has increased as well to more than double for all tree species.

Figure 3 shows schematically tree hardnesses

obtained by means of the invention compared to natural tree species known to be hard. As appears from the figure, across the grain hardnesses of spruce and pine compressed by the method are considerably greater than the respective strengths of natural oak, rosewood etc. Pine and spruce material obtained by means of the method can thus be used for purposes requiring very hard surface material, such as for floor coverings and the like. If the across the grain hardness values of alder respective aspen compressed by means of the method and shown in Figure 2 are compared, they can be found to show strength values corresponding to those of natural beech and teak.

Figure 4 compares the bending strength of pieces of wood produced by compressing by the method of the invention to the natural bending strength thereof, the figure showing clearly that the bending strength of spruce has risen to more than 2,5-fold at its best and to more than 1,5-fold at its worst.

As appears from the figures 2 to 4, even soft tree species can be made to very hard materials by means of the method of the invention, harder than the known hard tree species, which materials can be used for different purposes requiring strength and hardness both as coating material and as components of furniture and building industry, for instance. Thanks to the density and hardness, a simultaneous effect is that wood made by the method has a considerably better fire-resistance than conventional wood, and material made in this way can be used in places where fire-resistance is of a very great significance, as in public premises or load-bearing structures. The method of the invention can be implemented most efficiently when a relatively rapid compression is used, whereby an equal pressure effecting through the piece

of wood is provided most rapidly, thus forming the piece of wood most efficiently. By the method according to the invention, the final result of the piece of wood is a compressed piece of wood having a throughout equal strength and hardness, which has not been possible to provide by the known solutions. Also wood material being a little decayed at some place as well as knotty wood material may well be used for applying the method, since these weaknesses are eliminated by means of the method, because the knot and the resin material or another material around the knot are then compressed in a corresponding manner and become dense and hard, adhering undetachably to the remaining wood material. By means of the method, so-called undesirable tree material can be used efficiently for a useful purpose, which up till now has required first-class wood material. At the same time, the raw wood quality improves and drying defects caused by normal wood drying are avoided. By using the method of the invention, raw wood material can be utilized efficiently, because the stages of operation before the compression are very few and raw wood material is thus wasted very little. Similarly, the method requires a substantially smaller amount of work for providing the final result than conventional sawing technique does. When compressing raw wood to a suitable shape, rectangular or square finished products are obtained from round wood material, due to which a final working is not absolutely necessary at all, leading to that both the amount of work and loss of material decrease further.

Figure 5 shows a schematic block diagram of another method of the invention, in which each step relating to the manufacture is indicated as a separate block. At a heating step 14, the ends of a com-

pressible piece of wood are provided with electrodes, and then an electric current is conducted through the piece of wood so that the liquid contained in the wood and thus, through the liquid, the whole wood material is heated to a suitable softness. The piece of wood has preferably the same cross-section along the whole length, i.e. its material volume is substantially the same at each cross-section point. The piece of wood may be curved or bent, because it does not break when compressed in a heated state. The compressible piece of wood is moist or probably saturated with liquid. The wood may then come from a nearly freshly cut tree, which has not had time to dry yet and is thus saturated with its growing liquids. The piece of wood can also be saturated with water afterwards, whereby a saturation preferably occurs by positioning the pieces of wood to stand in a water basin so that one end of the piece of wood is on the water level or above it. The saturation then takes place rapidly and securely under the influence of capillary effect.

After the heating 14, the piece of wood is compressed slowly in the direction transverse to the fibres into a desired shape, whereby it straightens, or it can also be made curved or perhaps even bent in a desired manner. A desired cross-section may be provided at the same time by selecting the shape of compressing jaws, whereby it is, for instance, possible to compress from a round piece of wood a rectangular piece of wood or a piece of wood provided with recesses, such as a door frame or another corresponding piece of wood having a multiformed cross-section. At a compression 15, the surface of the piece of wood is densified and becomes dense and hard. If the compression ratio remains suitable, the heart portion of the

wood remains softer than the surface. At the manufacture of door frames or window frames, for instance, the insulating capacity of the wood is then partly maintained, while the surface portion can be made in a desired manner durable and dense for fastening of fittings and, on the other hand, weather resistant because of its density. The compression ratio can be kept greater, if desired, due to which are obtained throughout dense and hard pieces of desired shape, which can be used as such for various purposes. The compression is followed by a heating 16, a controlled temperature drop 17 and a cooling 18.

Figure 6 shows schematically a side view of another compressing equipment suitable for implementing the method of the invention. A compressing unit 19 is formed by compressing jaws 6 and 7 and a compression cylinder 5 pressing the compressing jaw 7. A piece of wood 11 is positioned between the compressing jaws 6 and 7, where a separate form part 6a, for instance, may also be positioned to provide a shoulder at the compressed piece 11a. While the piece of wood 11 is between the compressing jaws 6 and 7, the jaw 7 is pressed by means of the cylinder 15 in the figure downwards, due to which the heated piece of wood 11 is formed to a compressed piece of wood 11a according to the space defined by the jaws. For making the properties of compressed pieces of wood used for the same purpose mutually similar, it is preferable to calibrate the cross-sections of the compressible pieces of wood 11 roughly in such a way that the cross-section area is substantially the same along the whole length. When the compressed piece of wood 11a has a desired form according to Figure 6 compressed by the compressing jaws 6 and 7 and the form part 6a, the heating and the temperature drop and the

cooling take place in the manner illustrated in connection with Figure 5. For keeping the piece of wood in the compressed form, separate compressing jaws 6 and 7 can be used, which are coupled to each other after the compression in such a way that the piece of wood 11a remains between them and the final measures may be performed by displacing the coupled compressing jaws 6 and 7 to the following step, while new separate compressing jaws are positioned in the compressing equipment for next compressible piece of wood. Another alternative is to perform the heating and the controlled temperature drop as well as the cooling in the compressing equipment by using fixed stationary compressing jaws 6 and 7, which is, however, a relatively slow procedure in view of bigger volumes of production and requires a plurality of separate compressing devices for providing a sufficient capacity.

Figure 7 shows schematically a heating device, by which a compressible piece of wood 11 can be preheated before compression and which device may be used for heating the compressed piece of wood 11a after the compression, respectively. The piece of wood is positioned between two electrodes 20 and 21 in such a way that, when heated, the electrodes are placed against the faces of the piece of wood 11. The electrodes 20 and 21 are connected by means of conductors 22 and 23 to a current source 24, which generates a voltage between the electrodes 20 and 21 so that a current flows between them through the piece of wood 11. The current source may feed either direct or alternating voltage, if only a suitable current is generated through the piece of wood 11 so that the entire piece of wood 11 is heated equally.

Above in the specification and the drawings,

the invention is described by way of example only and it is in no way restricted to that. The compressing equipment may have quite varying structures and the structure and operation of its jaws may be implemented rather freely. The essential thing is that a compressible piece of wood will be subjected to a similar compression along its whole length. The compressed piece of wood can be heated either, as described above, by conducting electric current through it in its longitudinal or even transverse direction or by heating the compressing jaws by electromagnetic radiation or in some other practicable manner. Correspondingly, the piece of wood can be cooled after the heating either by letting it cool by itself after the termination of the heating or, for instance, by cooling the compressing jaws in a controlled manner either with steam or water or in another suitable way.

20

Claims:

1. A method for making wood having at least
hard-pressed surface, in which method a piece of wood
5 is compressed to a volume smaller than its original
volume for increasing its density and hardness,
c h a r a c t e r i z e d in that a piece of wood
containing at least a predetermined amount of mois-
ture is compressed in a direction transverse to its
10 wood fibres and that the volume of the compressed
piece of wood to which it was initially compressed is
substantially maintained and that, having said vol-
ume, the compressed piece of wood as a whole is heat-
ed to a temperature of over 100 °C so that the materi-
15 als in the piece of wood plasticizing under the in-
fluence of heat can be made softer and to adhere to
the remaining wood material, in which case the mois-
ture contained in the wood provides, when evaporated,
an equal pressure inside the piece of wood while the
20 steam leaves the wood under the influence of pres-
sure, after which the piece of wood is cooled, which
makes the soft materials solidify, and the piece of
wood remains permanently in its compressed form and
volume.

25 2. A method according to claim 1, c h a r a c-
t e r i z e d in that the piece of wood is com-
pressed without preheating.

30 3. A method according to claim 2, c h a r a c-
t e r i z e d in that the piece of wood is com-
pressed substantially at room temperature.

4. A method according to claim 1, c h a r a c-
t e r i z e d in that the piece of wood is heated
before compression.

35 5. A method according to claim 4, c h a r a c-
t e r i z e d in that the piece of wood is heated by

conducting electric current through it.

5 6. A method according to claim 5, c h a r a c -
t e r i z e d in that the electric current is con-
ducted through the piece of wood in the direction of
the wood fibres.

10 7. A method according to any of the claims 1 to
6, c h a r a c t e r i z e d in that the piece of
wood is compressed in such a way that it is equally
compressed substantially along the whole cross-sec-
tion and that substantially all liquid has left the
piece of wood.

15 8. A method according to any of the claims 1 to
6, c h a r a c t e r i z e d in that the piece of
wood is compressed in such a way that it is substan-
tially equally compressed at the surface, but the
heart portion is less compressed than the surface.

20 9. A method according to any of the preceding
claims, c h a r a c t e r i z e d in that the piece
of wood is compressed to a predetermined cross-sec-
tional form and that the compressed piece of wood in
its compressed form and volume is cooled further to a
temperature at which the materials plasticized during
the heating solidify and fix the compressed piece of
wood permanently in its compressed form.

25 10. A method according to any of the preceding
claims, c h a r a c t e r i z e d in that the piece
of wood is heated after compression to a temperature
of over 500 °C.

30 11. A method according to any of the preceding
claims, c h a r a c t e r i z e d in that the tem-
perature of the piece of wood is lowered after the
heating substantially equally, until it is about 100
°C, and then the piece of wood is cooled rapidly.

35 12. A method according to any of the preceding
claims, c h a r a c t e r i z e d in that the piece

of wood is compressed when its moisture content is at least 12 %.

13. A method according to any of the preceding claims, characterized in that the piece
5 of wood is compressed when substantially saturated with water.

14. A method according to any of the preceding claims, characterized in that the piece
10 of wood is compressed when saturated with its own growing liquids without extra saturation.

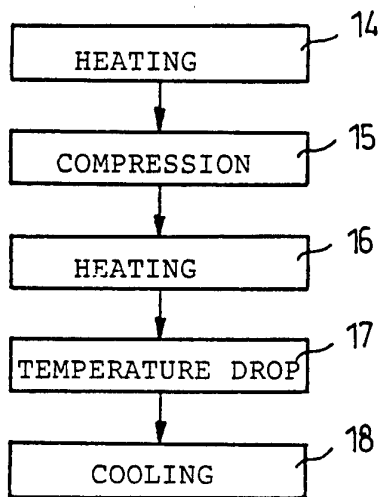
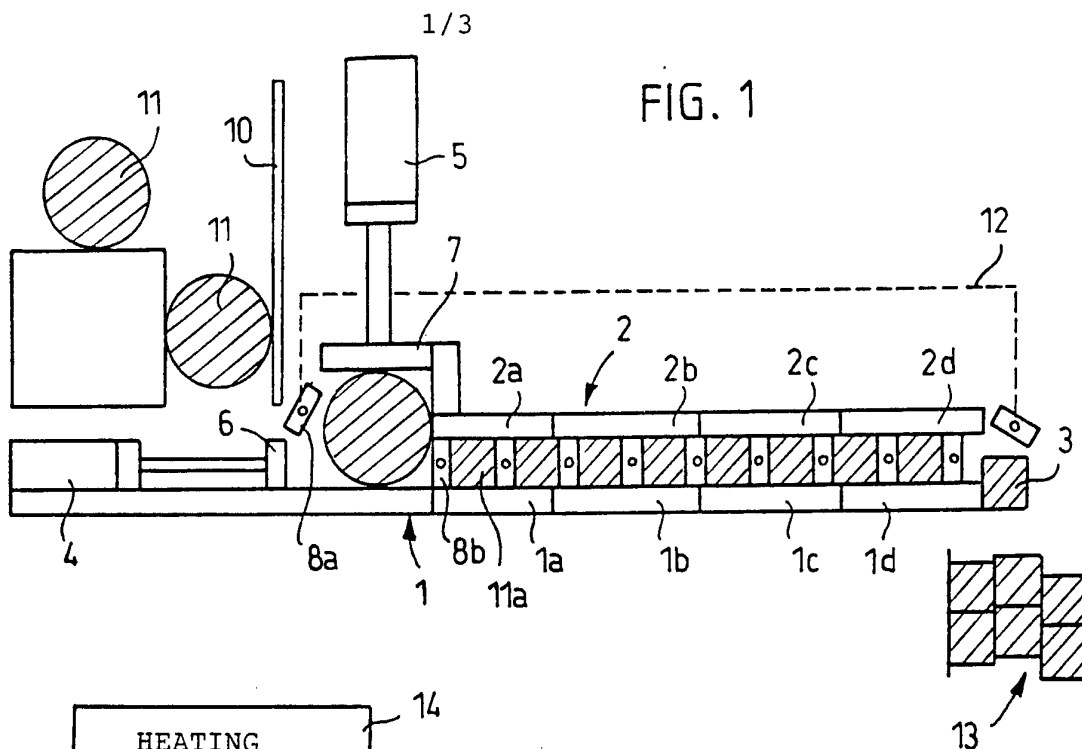

FIG. 5

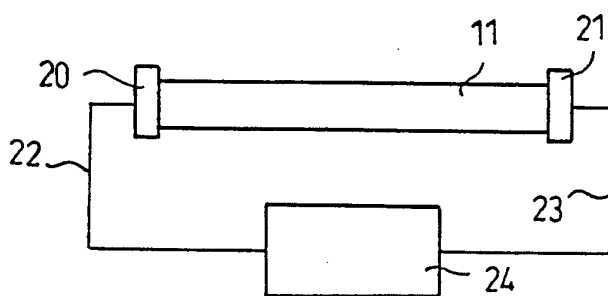
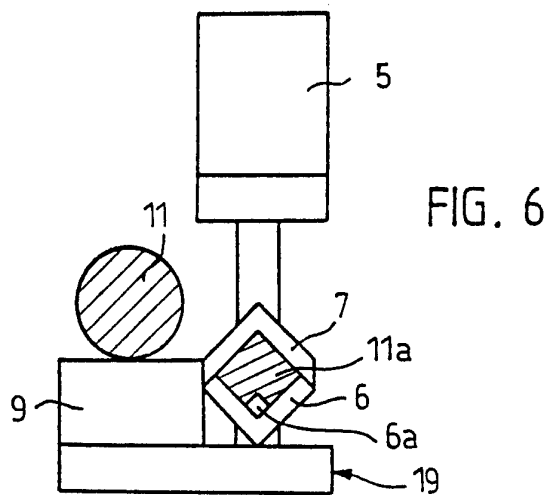

FIG. 2

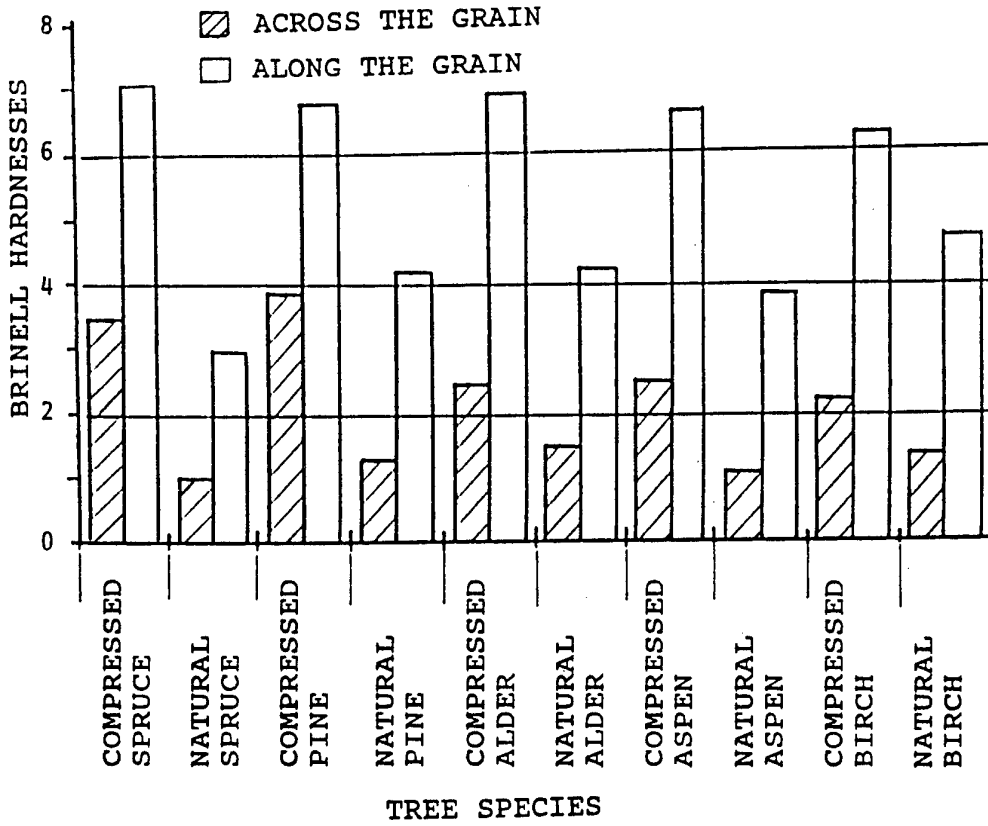

FIG. 3

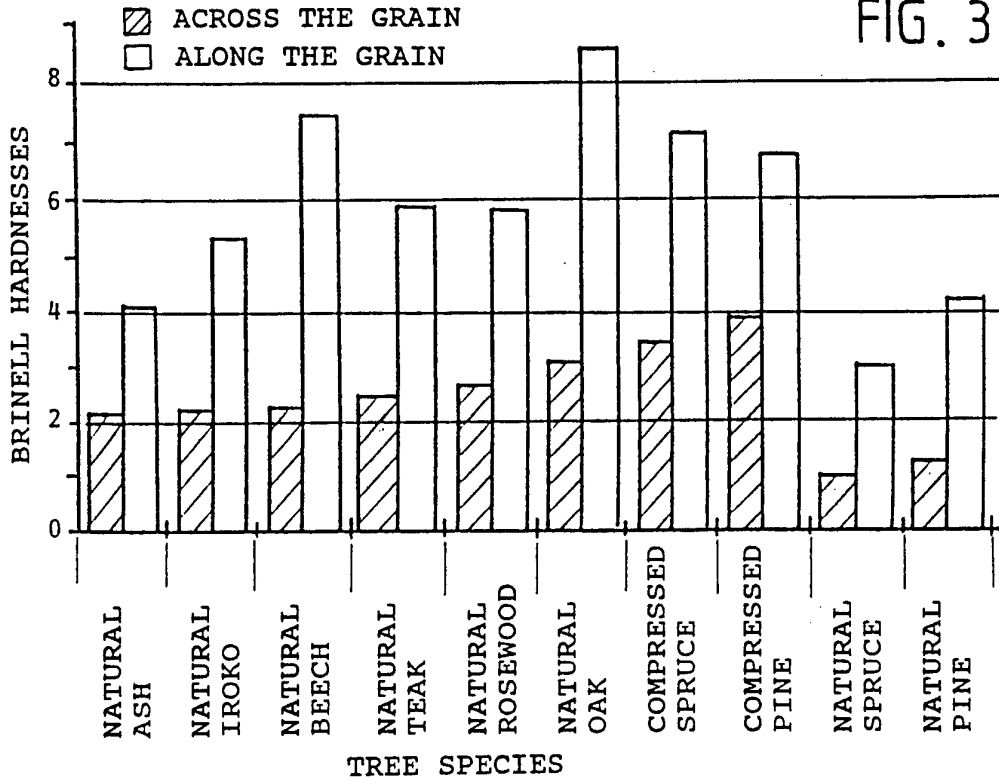
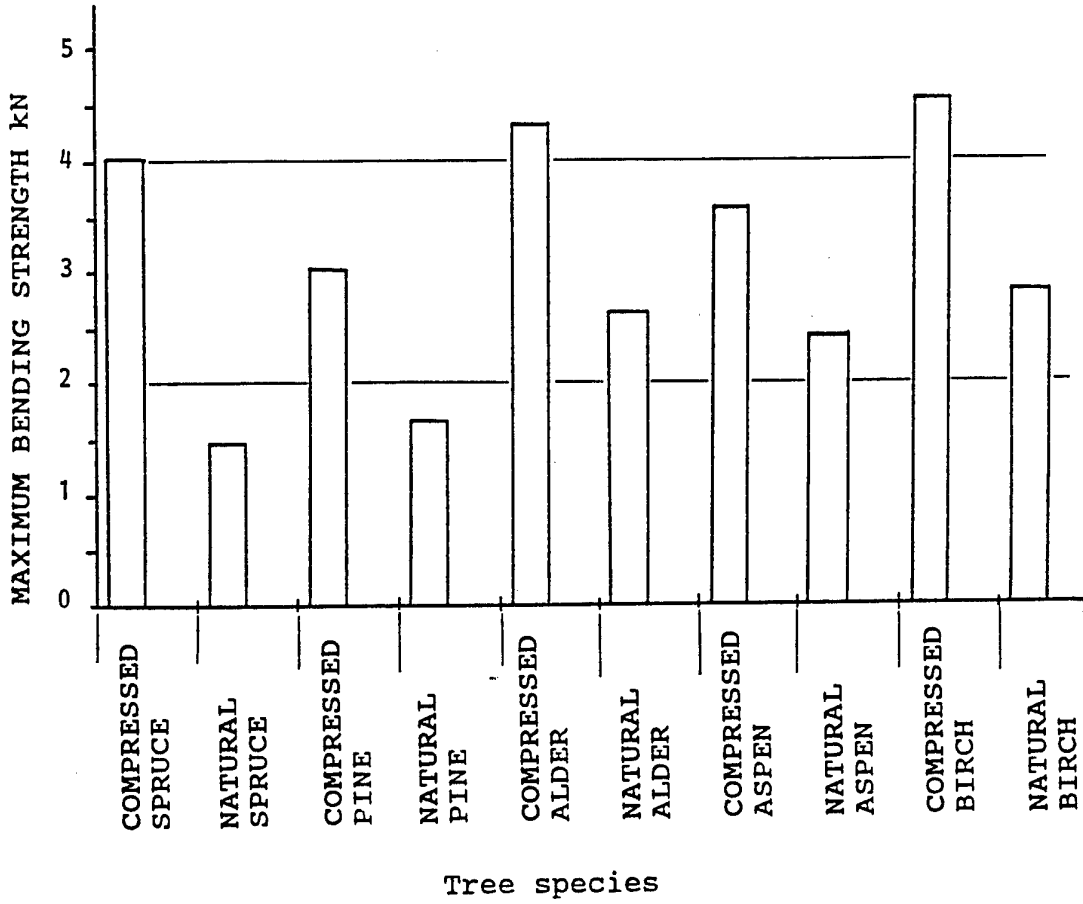

FIG. 4



INTERNATIONAL SEARCH REPORT

International application No.

PCT/FI 94/00088

| A. CLASSIFICATION OF SUBJECT MATTER | | |
|--|--|--|
| IPC : B27M 1/02 According to International Patent Classification (IPC) or to both national classification and IPC | | |
| B. FIELDS SEARCHED | | |
| Minimum documentation searched (classification system followed by classification symbols) | | |
| IPC : B27K, B27M | | |
| Documentation searched other than minimum documentation to the extent that such documents are included in the fields searched | | |
| SE,DK,FI,NO classes as above | | |
| Electronic data base consulted during the international search (name of data base and, where practicable, search terms used) | | |
| DIALOG, WPI | | |
| C. DOCUMENTS CONSIDERED TO BE RELEVANT | | |
| Category* | Citation of document, with indication, where appropriate, of the relevant passages | Relevant to claim No. |
| X | The Nikkei Weekly, Volume 30, No 1, June 1992, TAKASHI UEDA, "Microwave recipe yields straight logs" page 10 -- | 1,4-8 |
| A | SE, A, 8203011 (VALMET OY), 23 November 1982 (23.11.82), abstract -- | 5,6 |
| X | SE, B, 366241 (INSTITUT KHIMII DREVESINY AKADEMII NAUK LATVIISKOI SSR & EXPERIMENTALNAYA LYZHNAYA FABRIKA ESTONSKOGO RESPUBLIKANSKOGO SOVETA "DINAMO"), 22 April 1974 (22.04.74), page 1, line 4 - line 12; page 3, line 12 - page 4, line 8 -- | 1-3,7,9, 12-14 |
| <input checked="" type="checkbox"/> Further documents are listed in the continuation of Box C. <input checked="" type="checkbox"/> See patent family annex. | | |
| * Special categories of cited documents: "A" document defining the general state of the art which is not considered to be of particular relevance "E" erlier document but published on or after the international filing date "L" document which may throw doubts on priority claim(s) or which is cited to establish the publication date of another citation or other special reason (as specified) "O" document referring to an oral disclosure, use, exhibition or other means "P" document published prior to the international filing date but later than the priority date claimed | | "T" later document published after the international filing date or priority date and not in conflict with the application but cited to understand the principle or theory underlying the invention "X" document of particular relevance: the claimed invention cannot be considered novel or cannot be considered to involve an inventive step when the document is taken alone "Y" document of particular relevance: the claimed invention cannot be considered to involve an inventive step when the document is combined with one or more other such documents, such combination being obvious to a person skilled in the art "&" document member of the same patent family |
| Date of the actual completion of the international search | | Date of mailing of the international search report |
| 15 June 1994 | | 17 -06- 1994 |
| Name and mailing address of the ISA/ Swedish Patent Office Box 5055, S-102 42 STOCKHOLM Facsimile No. +46 8 666 02 86 | | Authorized officer Björn Salén Telephone No. +46 8 782 25 00 |

INTERNATIONAL SEARCH REPORT

International application No.

PCT/FI 94/00088

| C (Continuation). DOCUMENTS CONSIDERED TO BE RELEVANT | | |
|---|---|-----------------------|
| Category* | Citation of document, with indication, where appropriate, of the relevant passages | Relevant to claim No. |
| X | Derwent's abstract, No 93-334469/42, week 9342, ABSTRACT OF SU, 1766659 (VORON FORESTRY INST.), 7 October 1992 (07.10.92) -- | 1,2,7,12,13 |
| X | CH, A, 417925 (A/S JUNCKERS SAVVAERK), 15 February 1967 (15.02.67), see claim -- ----- | 1,7,12,13 |

INTERNATIONAL SEARCH REPORT
Information on patent family members

28/05/94

International application No.
PCT/FI 94/00088

| Patent document cited in search report | Publication date | Patent family member(s) | Publication date |
|--|------------------|-------------------------|------------------|
| SE-A- 8203011 | 23/11/82 | NONE | |
| SE-B- 366241 | 22/04/74 | NONE | |
| CH-A- 417925 | 15/02/67 | NONE | |