

FIG. 1

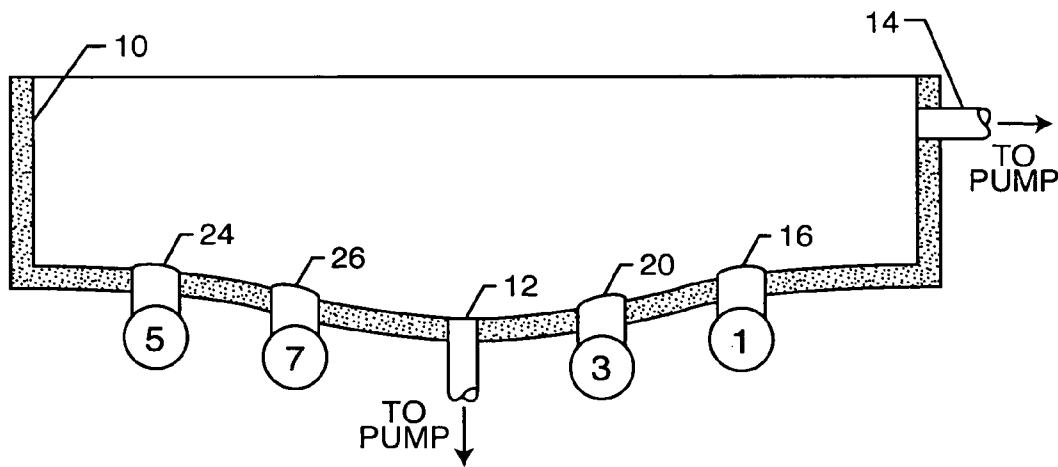

FIG. 2

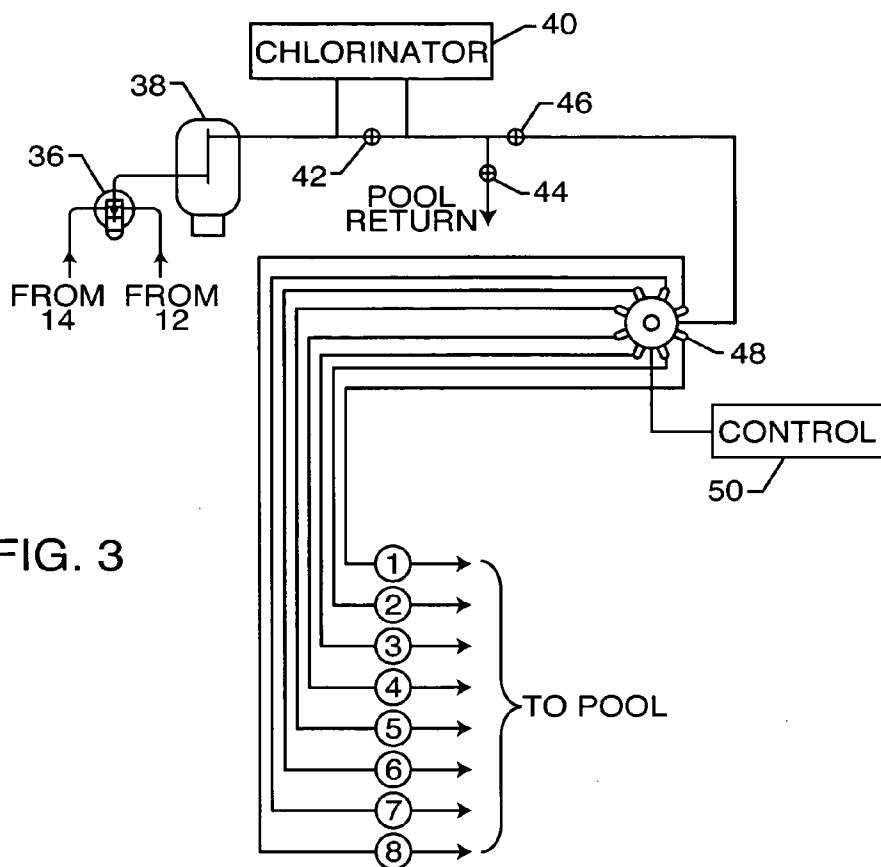

FIG. 3

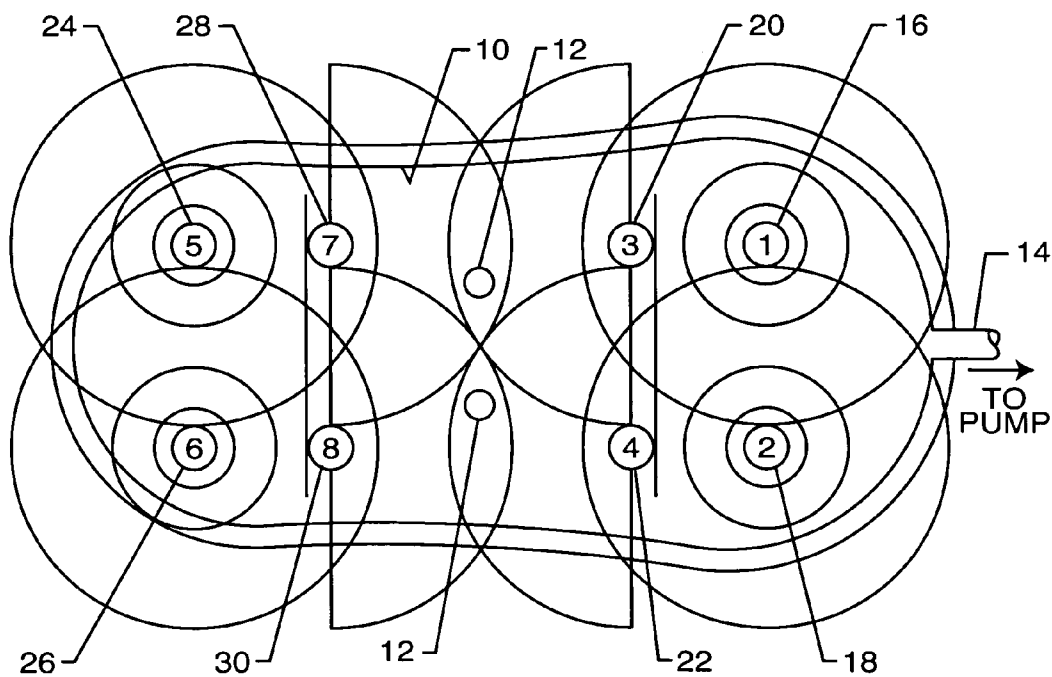

FIG. 4

PROGRAMMED POOL CLEANING SYSTEM

RELATED APPLICATIONS

[0001] This application is a continuation-in-part of co-pending U.S. Ser. No. 10/282,653, filed Oct. 28, 2002, which is in turn a continuation-in-part of U.S. Ser. No. 09/861,403, filed May 17, 2001, and now abandoned, which is related in turn to U.S. Pat. No. 6,345,645, issued Feb. 12, 2002.

BACKGROUND OF THE INVENTION

[0002] Many modern swimming pools are constructed with in-floor automatic cleaning systems. These systems substantially reduce, if not eliminate, the time which must be spent by pool owners or pool maintenance companies in cleaning the pools. Such cleaning systems typically include a plurality of spaced retractable cleaning heads located at various positions in the bottom, walls and steps of the pool to effect indexed sweeping of the floor, walls and steps of the pool with jets of water adjacent to and parallel to the pool surface surrounding the cleaning heads. This action moves dirt and debris which has settled onto the surface adjacent the heads away from the region being cleaned. Hopefully, the dirt ultimately moves toward the floor drain, where it then is removed by the suction inlet of a recirculating pump system for removal by filtration from the water of the pool, prior to returning the water to the cleaning heads. The outlet side of the recirculating pump system supplies the water back to the cleaning heads after passing it through a filter.

[0003] While such in-floor pool cleaning systems are a substantial improvement over pools without such systems, ultimate cleaning still does not occur. When the cleaning heads are placed around the perimeter of the pool, these heads activate currents which blow debris up the wall and/or the corners of the pool, holding the debris suspended in the currents, and then actually depositing the debris on the other side of the cleaning head. As a consequence, when the head indexes around and points to the interior of the pool, the water currents push the debris toward the center of the pool, eventually directing it to the deep end of the pool, where the suction drain typically is located.

[0004] Theoretically, this is good, until a second row or bank of cleaning heads intermediate the first ones and the drain operates. All of the cleaning heads in the bottom or floor of conventional in-floor pool cleaning systems have a 360° indexed circle of rotation. As a consequence, the second or intermediate row of heads has a tendency to blow the debris and dirt back behind the first row of heads to start the sequence all over again. Thus, dirt in such conventional in-floor pool cleaning systems is simply transferred back and forth, from one set of heads to the other, into the "just cleaned" zones.

[0005] It is desirable to provide a pool cleaning system for efficiently transferring dirt and debris from all parts of the pool toward the suction drains located in the bottom of the pool, with minimal back-and-forth transfer of the debris from one bank of cleaning heads to another.

SUMMARY OF THE INVENTION

[0006] It is an object of this invention to provide an improved swimming pool cleaning system.

[0007] It is another object of this invention to provide an improved method for cleaning a swimming pool.

[0008] It is an additional object of this invention to provide an improved in-floor cleaning system and method for a swimming pool.

[0009] It is a further object of this invention to provide an improved in-floor cleaning system and method for a swimming pool, which utilizes banks of programmed cleaning heads to direct debris toward the suction return or drain of the swimming pool.

[0010] In accordance with a preferred embodiment of the invention, a cleaning system and method for a swimming pool is operated in conjunction with a recirculating pump system which has a suction water inlet and a water outlet. A suction return of the swimming pool is connected to the suction water inlet of the recirculating pump system. The water outlet of the recirculating pump system is connected to at least a first rotatable cleaning head in the floor of the pool, located near an end of the pool for cleaning in a 360° circle. At least a second rotatable cleaning head is located in the floor of the pool between the first cleaning head and the suction return for cleaning in substantially a 180° arc directed toward the suction return of the pool. The water outlet of the recirculating pump system is connected to the first and second cleaning heads for alternately supplying water from the outlet of the recirculating pump system to these cleaning heads.

[0011] Other features and advantages of the present invention will become more apparent from the following detailed description taken in conjunction with the accompanying drawings which illustrate, by way of example, the principles of the invention.

BRIEF DESCRIPTION OF THE DRAWINGS

[0012] The accompanying drawings illustrate the invention. In such drawings:

[0013] **FIG. 1** is a top diagrammatic view of a swimming pool cleaning system incorporating a preferred embodiment of the invention;

[0014] **FIG. 2** is a diagrammatic cross-sectional view of a swimming pool cleaning system incorporating the preferred embodiment of the invention;

[0015] **FIG. 3** is a diagrammatic representation of a recirculating pump system employed in conjunction with the embodiment shown in **FIGS. 1 and 2**; and

[0016] **FIG. 4** is a top diagrammatic view of the same pool shown in **FIG. 1** illustrating the manner of operation of a preferred embodiment of the invention.

DETAILED DESCRIPTION OF THE PREFERRED EMBODIMENT

[0017] Reference now should be made to the drawings, in which the same reference numbers are used throughout the different figures to designate the same or similar components. Initially, reference should be made to **FIGS. 1 and 2**, which show a diagrammatic top view and a cross-sectional view, respectively of a typical swimming pool in which the preferred embodiment of the invention is employed.

[0018] The swimming pool **10** generally has at least one shallow end, or is shallow at both ends with a deeper portion in which a suction return in the form of a drain **12** (or pair

of drains, as shown in **FIG. 1**) is located. The pool typically is filled with water to a water level near the top edge of the pool, whereby the pool defines submerged bottom and side wall surfaces. In a pool which utilizes an automatic in-floor cleaning system using pop-up indexing cleaning heads, the cleaning heads are located at various positions in the submerged surfaces such as the bottom and/or steps of the pool, as indicated in **FIG. 1**. The locations of different cleaning heads are designated by the circled designations **1** through **8**, carrying the reference numbers **16, 18, 20, 22, 24, 26, 28** and **30** for different groups or banks of cleaning heads. In the simplified illustration of **FIGS. 1 and 2**, only one cleaning head is shown for each of the banks; although it should be understood that two or three, or perhaps even more, cleaning heads could be utilized for each of the different bank designations **1** through **8**, if desired. The number of cleaning heads on each bank or in each group, for any given pool system, depends upon the size of the recirculating pump used in the system, as well as the characteristics of the water distribution valve used to alternately supply water to the different banks of cleaning heads in a pre-programmed sequence.

[0019] A typical swimming pool of the type shown in **FIGS. 1 and 2** also generally includes another suction return in the form of a skimmer **14** (or water trap for a vanishing edge pool), which also is connected to the suction inlet of the water distribution system, along with the connection of the drain **12** in the bottom of the pool. In the operation of a pool of the type shown in **FIG. 1**, a recirculating water supply is utilized. A preferred arrangement of such a water supply is shown in **FIG. 3**. This recirculating water supply includes a pump **36**, the vacuum side of which is connected to lines (not shown) to the skimmer **14** and the floor drains **12**. This is the water which is pulled into the suction inlet of the pump **36** to remove the water from the pool for filtration and recirculation. The outlet side of the pump **36** is connected to a filter **38**, which may be of any one of a number of standard pool filter configurations.

[0020] Water flowing from the output of the filter **38** then either may pass directly through an open valve **42**, or, if the valve **42** is closed, through a chlorinator **40** for automatically treating the water passing out of the filter **38**. Two other valves **44** and **46** determine the path which will be taken by the water coming from the outlet side of the pump **36** and the filter **38**, and/or the chlorinator **40**. If the valve **46** is closed and the valve **44** is open, all of the water is returned to a single (or a plurality) of pool return inlets into the pool, typically bypassing the in-floor cleaning system described above in conjunction with **FIGS. 1 and 2**. If the valve **44** is closed and the valve **46** is open, all of the water passing out of the filter **38**, whether directly through the valve **42** or through the chlorinator **40**, is supplied to a water distribution valve **48**, shown as having eight different outlet pipes or banks, numbered **1** through **8**, in circles in the bottom of **FIG. 3**.

[0021] The water distribution valve **48** ideally is of the type described in the above mentioned U.S. Pat. No. 6,345,645; although the valve **48** could be any one of a number of water distribution valves currently used in conjunction with automatic in-floor swimming pool cleaning systems. The basic operation of such valves, including the valve **48**, is that the water supplied to the inlet of the valve, such as through the valve **46**, is directed through the outlet ports **1** through

8, one at a time. Consequently, the outlet ports **1** through **8** individually receive the full output of the recirculating pump **36** at any given time when the recirculation system is in operation.

[0022] In the system shown in **FIG. 3**, a control circuit **50** controls the dwell time of the water distribution valve **48** according to the above mentioned U.S. Pat. No. 6,345,645; so that the time at which water is supplied under pressure to each of the outlet ports **1** through **8** may be varied in accordance with the use of, and location of, those ports. For example, port No. **1** of the valve **48** is illustrated in **FIGS. 1 and 2** as being connected to the cleaning head (or bank of heads) **16** located in a shallower portion of the pool adjacent the right-hand end, as viewed in both **FIGS. 1 and 2**. The head **16** on port **1**, as well as the head or heads **18** on port **2** and those on ports **5** and **6** designated with reference Nos. **24** and **26** in the drawing of **FIGS. 1 and 2**, are located adjacent respective ends of the pool. The head or banks of heads connected to outlet ports **3, 4, 7** and **8** and numbered, respectively, **20, 22, 28** and **30** in **FIG. 1**, are located in a deeper portion of the pool, closer to the location of the drains **12**.

[0023] In the operation of the cleaning system, the dwell times of each of these different banks is adjustable by means of the control **50** to optimize the effective cleaning which is accomplished by each head or bank of heads in the system. The manner in which this is done is described in greater detail in the above mentioned U.S. Pat. No. 6,345,645. It should be noted, however, that the system according to the present invention may be operated in conjunction with standard water jet distribution valves as well, in which the dwell time of each of the different ports is the same, that is, where the dwell time is not varied from one port to the other.

[0024] Reference should now be made to **FIG. 4** taken again in conjunction with the illustrations of **FIGS. 1 and 2**. In the system under consideration, the water distribution valve **48** sequentially supplies water under pressure to each of its outlet ports numbered **1** through **8**, which are connected to corresponding outlets numbered **1** through **8** in the bottom of the pool, as previously described. In the system disclosed here, the outlet cleaning heads connected to the ports **1, 2, 5** and **6** are located with the cleaning heads **1** and **2** near the right-hand end of the pool, and the cleaning **5** and **6** located near the left-hand end of the pool as viewed in **FIGS. 1, 2** and **4**. These cleaning heads, numbered **16, 18, 24** and **26**, are located sufficiently near the walls and ends of the pool to direct the indexed cleaning water, supplied to them when the corresponding port of the valve **48** is provided with water, to step in a 360° circle to sweep the debris from the ends and walls of the pool located adjacent these heads. Such a 360° cleaning is indicated by three concentric circles around each of these heads **16, 18, 24** and **26**, as illustrated in **FIG. 4**. The circles are shown as extending beyond the edges of the pool **10** to indicate the cleaning force is applied to the walls and sides of the pool where the walls and sides of the pool connect with the bottom to thoroughly sweep debris from all surfaces of the pool. In actuality, the sweep of the heads **16, 18, 24** and **26** cannot extend beyond the pool perimeter, as is obvious. The operation of the pool cleaning heads connected to the ports **1, 2, 5** and **6** and designated as **16, 18, 24** and **26** is standard 360° rotation, of the type currently employed with pop-up, in-floor cleaning heads manufactured by various companies.

One illustrative full-circle rotatable cleaning head construction is shown and described in U.S. Pat. No. 4,462,546, which is incorporated by reference herein.

[0025] The cleaning heads of banks **3**, **4**, **7** and **8** in the pool bottom or floor, however, are designed to index 180° and then return the opposite direction 180° to sweep debris from these heads directly toward the drains **12**, without rotating full circle to blow debris back toward the heads **16**, **18**, **24** and **26**. The heads **20**, **22**, **28** and **30** are supplied with water under pressure from the distribution valve **48** in the same manner as the banks of heads located throughout the bottom of in-floor pool systems have been operated in the past. The difference, however, is that the heads **20**, **22**, **28** and **30** do not do a full circle (360°) rotation; but they are pointed and programmed to sweep debris only from the point of the heads on down toward the drains.

[0026] As is evident from an examination of the diagram of FIG. 4, all of the circles or semi-circles of cleaning of the different heads overlap one another. This is to insure that the entire floor of the pool is swept by these heads.

[0027] While the specific construction of the part-circle rotating heads **20**, **22**, **28** and **30**, including the associated mechanism or mechanisms for reversibly indexing these heads within a part-circle arcuate path of about 180°, is not shown and described in detail herein, persons skilled in the art will recognize and appreciate that suitable reverse mechanisms of the type used in reversible part-circle pop-up irrigation sprinklers may be employed in an otherwise standard full-circle rotary head of the above mentioned type employed with pop-up, in-floor cleaning heads manufactured by various companies. Alternately, such cleaning heads may be modified by use of rotary drive mechanisms used in irrigation sprinklers and suitably adjusted or set for full-circle or part-circle rotation in accordance with the location of each specific pop-up cleaning head in an in-floor cleaning system. Still further, using such reversing mechanisms as described, the part-circle rotating heads may be adjustably set for back-and-forth, reciprocal part-circle rotation through an arcuate path that is greater than or less than 180°, if desired and as appropriate for the specific location of each cleaning head in the in-floor cleaning system.

[0028] Illustrative pop-up irrigation sprinklers employing reversible and adjustably set part-circle reversing mechanisms that can be used in the production of part-circle pop-up cleaning heads for an in-floor pool cleaning system as described herein, are shown and described in detail in U.S. Pat. Nos. 3,187,056; 3,713,584; 3,724,757; 3,930,618; 4,253,608; 4,417,691; 4,625,914; 4,634,052; 4,699,321; 4,708,291; 4,87,558; 4,955,542; 5,148,991; and 5,383,600; as well as U.S. Publication U.S.2002/0092924, all of which are incorporated by reference herein.

[0029] In the operation of the system shown in FIGS. 3 and 4, the sequential operation is that the head **16** first is supplied with water under pressure from the distribution valve **48**. Then, the head **18** is supplied with water under pressure. Following this operation, the heads **20** and **22** connected to the ports **3** and **4**, respectively, are operated to effect their indexed cleaning in the semi-circle or 180° arcs, as shown. Following this operation, a similar set of operations takes place for the heads **24**, **26**, **28** and **30** on the opposite side of the pool. Over a period of time, the indexed cleaning of the heads **16**, **18**, **24** and **26** in a 360° circle, and

the heads **20**, **22**, **28** and **30** in 180° arcs, tends to optimize the cleaning of the pool. This occurs because the heads **20**, **22**, **28** and **30** do not operate to blow debris back toward the heads **16**, **18**, **24** and **26**. This improves the efficiency and cleaning action of the in-floor cleaning system employing a combination of 360° and 180° heads oriented as shown in FIG. 4.

[0030] While the suction returns connected to the suction inlet of the pump **36** have been described primarily in conjunction with a floor drain **12**, it should be noted that the system also may be used with pools which do not connect a floor drain to the suction inlet of the pump. This use of the term "suction inlet" is intended to cover such pool systems.

[0031] The foregoing description of the preferred embodiment of the invention should be considered as illustrative and not as limiting. Various changes will occur to those skilled in the art for performing substantially the same function, in substantially the same way, to achieve substantially the same result, without departing from the true scope of the invention as defined in the appended claims.

What is claimed is:

1. A cleaning system for swimming pools including in combination:

a recirculating pump system having a suction water inlet and a water outlet;

a pool having first and second ends and a bottom;

a suction return in the bottom of the pool;

a connection between the suction return and the suction inlet of the recirculating pump system;

at least one first rotatable cleaning head in the bottom of the pool for cleaning in a 360° circle;

at least one second rotatable cleaning head in the bottom of the pool between the at least one first cleaning head and the suction return for cleaning in substantially a 180° arc directed substantially toward the suction return; and

means connected between the water outlet of the recirculating pump system and the at least one first cleaning head and the at least one second cleaning head for alternately delivering water from the outlet of the recirculating pump system to the at least one first cleaning head and the at least one second cleaning head.

2. The cleaning system according to claim 2 wherein the means for alternately supplying water to the at least one first rotatable cleaning head and the at least one second rotatable cleaning head includes a water distribution valve.

3. The cleaning system according to claim 2 wherein the recirculating pump system delivers water from the water outlet thereof to the at least one first rotatable cleaning head for a first predetermined period of time and supplies water to the at least one second rotatable cleaning head for a second predetermined period of time.

4. The cleaning system according to claim 3 wherein a plurality of first rotatable cleaning heads are located in the bottom of the pool for indexed cleaning in a 360° circle.

5. The cleaning system according to claim 4 further including a plurality of second rotatable cleaning heads in the bottom of the pool between each of the plurality of first

rotatable cleaning heads and the suction return for cleaning in substantially a 180° arc directed toward the suction return.

6. The cleaning system according to claim 1 wherein the suction return is a drain and further including at least one additional first rotatable cleaning head in the bottom of the pool for cleaning in a 360° circle; and

further including at least one additional second rotatable cleaning head in the bottom of the pool between the additional first cleaning head and the drain for cleaning a substantially a 180° arc directed substantially toward the drain;

wherein the water outlet of the recirculating pump system further is connected to the additional first and additional second cleaning heads for alternately delivering water from the outlet of the recirculating pump system to the additional first cleaning head and the additional second cleaning head.

7. The cleaning system according to claim 6 wherein the first rotatable cleaning heads are located near first and second opposite ends of the pool and the second rotatable cleaning heads are located intermediate the first rotatable cleaning heads and the drain of the pool.

8. The cleaning system according to claim 1 wherein a plurality of first rotatable cleaning heads are located in the bottom of the pool for indexed cleaning in a 360° circle.

9. The cleaning system according to claim 8 further including a plurality of second rotatable cleaning heads in the bottom of the pool between the plurality of first cleaning heads and the suction return in the pool for cleaning in substantially a 180° arc directed toward the suction return in the pool.

10. A method for cleaning swimming pools where a drain is located in the swimming pool and first and second cleaning heads also are located in the bottom of the pool between the one end of the pool and the drain, the method comprising the steps of:

operating the first cleaning head in the bottom of the pool to clean in a 360° circle;

locating the second cleaning head between the first cleaning head and the drain; and

operating the second cleaning head in the bottom of the swimming pool to sweep debris substantially in a 180° arc directed away from the first cleaning head and toward the suction return of the pool.

11. The method according to claim 10 further including the step of operating the first and second cleaning heads in an alternating manner.

12. A cleaning system for swimming pools including in combination:

a recirculating pump system having a suction water inlet and a water outlet;

a pool having a suction return;

a connection between the suction return and the suction water inlet of the recirculating pump system;

at least one first rotatable cleaning head in the pool for cleaning in a substantially 360° circle;

at least one second rotatable cleaning head in the pool between the at least one first cleaning head and the suction return for cleaning in substantially a part-circle

arc directed substantially away from the at least one first cleaning head and directed substantially toward the suction return; and

means connected between the water outlet of the recirculating pump system and the at least one first cleaning head and the at least one second cleaning head for alternately delivering water from the outlet of the recirculating pump system to the at least one first cleaning head and the at least one second cleaning head.

13. The cleaning system according to claim 12 wherein said at least one second rotatable cleaning head indexes reversibly back-and-forth within said substantially part-circle arc.

14. The cleaning system according to claim 12 wherein the means for alternately supplying water to the at least one first rotatable cleaning head and the at least one second rotatable cleaning head includes a water distribution valve.

15. The cleaning system according to claim 14 wherein the means for alternately supplying water to the at least one first rotatable cleaning head and the at least one second rotatable cleaning head further includes a programmable control for programmably selecting the period of time said at least one first and second rotatable cleaning heads are respectively supplied with water from the outlet of said recirculating pump system.

16. The cleaning system according to claim 12 wherein the recirculating pump system delivers water from the water outlet thereof to the at least one first rotatable cleaning head for a first predetermined period of time and then supplies water to the at least one second rotatable cleaning head for a second predetermined period of time.

17. The cleaning system according to claim 12 wherein said pool further includes a bottom, and further wherein said at least one first rotatable cleaning head and said at least one second rotatable cleaning head are located in said pool bottom.

18. The cleaning system according to claim 12 wherein said at least one first rotatable cleaning head comprises a plurality of first rotatable cleaning heads located in the pool each for indexed cleaning in a substantially 360° circle.

19. The cleaning system according to claim 18 wherein said at least one second rotatable cleaning head comprises a plurality of second rotatable cleaning heads located in the pool respectively between each of the plurality of first rotatable cleaning heads and the suction return for indexed cleaning in a substantially part-circle arc directed substantially away from the associated one of said plurality of first cleaning heads and directed substantially toward the suction return.

20. The cleaning system of claim 19 wherein said pool further includes a bottom, and further wherein said plurality of first and second cleaning heads are located in said pool bottom.

21. The cleaning system of claim 20 wherein said suction return is located in said pool bottom.

22. The cleaning system according to claim 20 wherein the first rotatable cleaning heads are located near first and second opposite ends of the pool and the second rotatable cleaning heads are located intermediate the first rotatable cleaning heads and the suction return of the pool.

23. A method for cleaning swimming pools where a suction return is located in the swimming pool and first and

second cleaning heads also are located in the pool between the one end of the pool and the suction return, the method comprising the steps of:

operating the first cleaning head to clean in a substantially 360° circle;

locating the second cleaning head between the first cleaning head and the suction return; and

operating the second cleaning head to sweep debris substantially in a part-circle arc directed substantially away from the first cleaning head and directed substantially toward the suction return of the pool.

24. The method according to claim 23 further including the step of operating the first and second cleaning heads in an alternating manner.

* * * * *