



(86) Date de dépôt PCT/PCT Filing Date: 2006/08/17
(87) Date publication PCT/PCT Publication Date: 2007/06/21
(85) Entrée phase nationale/National Entry: 2008/05/23
(86) N° demande PCT/PCT Application No.: US 2006/032204
(87) N° publication PCT/PCT Publication No.: 2007/070124
(30) Priorité/Priority: 2005/12/13 (US11/301,632)

(51) Cl.Int./Int.Cl. *D21F 11/14* (2006.01)
(71) Demandeur/Applicant:
KIMBERLY-CLARK WORLDWIDE, INC., US
(72) Inventeurs/Inventors:
UNDERHILL, RICHARD, US;
SONNENBERG, JEFF, US;
VOGT, KEVIN J., US;
MATHEWS, JEFF, US
(74) Agent: BORDEN LADNER GERVAIS LLP

(54) Titre : PRODUITS EN PAPIER POSSEDANT DES PROPRIETES AVANCEES DE DIRECTION TRAVERS
(54) Title: TISSUE PRODUCTS HAVING ENHANCED CROSS-MACHINE DIRECTIONAL PROPERTIES

(57) **Abrégé/Abstract:**

Tissue products are disclosed having desirable strength, stretch and softness properties. In particular, the tissue products exhibit relatively high strength while still having a relatively low stiffness and a significant amount of stretch. The tissue webs generally comprise uncreped through-air dried webs. In accordance with the present disclosure, the webs are formed in a through-air drying process in which the transfer fabric and the through-air drying fabric are both textured fabrics having a substantially uniform high strain distribution in the cross-machine direction. Various improvements in properties in the cross-machine direction are exhibited by deforming or molding a tissue web against one or more of the fabrics during the tissue making process.



(12) INTERNATIONAL APPLICATION PUBLISHED UNDER THE PATENT COOPERATION TREATY (PCT)

(19) World Intellectual Property Organization
International Bureau



(43) International Publication Date
21 June 2007 (21.06.2007)

PCT

(10) International Publication Number
WO 2007/070124 A1

(51) International Patent Classification:
D21F 11/14 (2006.01)

(74) Agents: CASSIDY, Timothy, A. et al.; DORITY & MANNING, P.A., P.o. Box 1449, Greenville, SC 29602-1449 (US).

(21) International Application Number:
PCT/US2006/032204

(81) Designated States (*unless otherwise indicated, for every kind of national protection available*): AE, AG, AL, AM, AT, AU, AZ, BA, BB, BG, BR, BW, BY, BZ, CA, CH, CN, CO, CR, CU, CZ, DE, DK, DM, DZ, EC, EE, EG, ES, FI, GB, GD, GE, GH, GM, HN, HR, HU, ID, IL, IN, IS, JP, KE, KG, KM, KN, KP, KR, KZ, LA, LC, LK, LR, LS, LT, LU, LV, LY, MA, MD, MG, MK, MN, MW, MX, MY, MZ, NA, NG, NI, NO, NZ, OM, PG, PH, PL, PT, RO, RS, RU, SC, SD, SE, SG, SK, SL, SM, SV, SY, TJ, TM, TN, TR, TT, TZ, UA, UG, US, UZ, VC, VN, ZA, ZM, ZW.

(22) International Filing Date: 17 August 2006 (17.08.2006)

(25) Filing Language: English

(26) Publication Language: English

(30) Priority Data:
11/301,632 13 December 2005 (13.12.2005) US

(84) Designated States (*unless otherwise indicated, for every kind of regional protection available*): ARIPO (BW, GH, GM, KE, LS, MW, MZ, NA, SD, SL, SZ, TZ, UG, ZM, ZW), Eurasian (AM, AZ, BY, KG, KZ, MD, RU, TJ, TM), European (AT, BE, BG, CH, CY, CZ, DE, DK, EE, ES, FI, FR, GB, GR, HU, IE, IS, IT, LT, LU, LV, MC, NL, PL, PT, RO, SE, SI, SK, TR), OAPI (BF, BJ, CF, CG, CI, CM, GA, GN, GQ, GW, ML, MR, NE, SN, TD, TG).

(71) Applicant (*for all designated States except US*): KIMBERLY - CLARK WORLDWIDE, INC. [US/US]; 401 N. Lake Street, Neenah, WI 54956 (US).

(72) Inventors; and

(75) Inventors/Applicants (*for US only*): UNDERHILL, Richard [US/US]; 726 Congress Place, Neenah, WI 54956 (US). SONNENBERG, Jeff [US/US]; W4719 Windsor Ct., Sherwood, WI 54169 (US). VOGT, Kevin, J. [US/US]; 404 1/2 Nicolet Blvd., Menasha, WI 54952 (US). MATHEWS, Jeff [US/US]; 1690 Golf Bridge Drive, Neenah, WI 54956 (US).

Published:

— with international search report

For two-letter codes and other abbreviations, refer to the "Guidance Notes on Codes and Abbreviations" appearing at the beginning of each regular issue of the PCT Gazette.

(54) Title: TISSUE PRODUCTS HAVING ENHANCED CROSS-MACHINE DIRECTIONAL PROPERTIES

(57) Abstract: Tissue products are disclosed having desirable strength, stretch and softness properties. In particular, the tissue products exhibit relatively high strength while still having a relatively low stiffness and a significant amount of stretch. The tissue webs generally comprise uncreped through-air dried webs. In accordance with the present disclosure, the webs are formed in a through-air drying process in which the transfer fabric and the through-air drying fabric are both textured fabrics having a substantially uniform high strain distribution in the cross-machine direction. Various improvements in properties in the cross-machine direction are exhibited by deforming or molding a tissue web against one or more of the fabrics during the tissue making process.

WO 2007/070124 A1

TISSUE PRODUCTS HAVING ENHANCED CROSS-MACHINE DIRECTIONAL PROPERTIES

BACKGROUND OF THE INVENTION

In the manufacture of tissue products such as bath tissue, a wide variety of product characteristics must be given attention in order to provide a final product with the appropriate blend of attributes suitable for the product's intended purposes. Improving the softness of tissues without compromising strength is a continuing objective in tissue manufacture, especially for premium products. Softness, however, is a perceived property of tissues comprising many factors including thickness, smoothness, and fuzziness.

In order to improve the softness of tissue products while retaining sufficient strength, various two-ply tissue products have been proposed. However, in terms of manufacturing economy, multiple-ply products are typically more expensive to produce than single-ply products. Thus, a need exists for a single-ply tissue product with high bulk and softness while retaining strength.

Traditionally, tissue products have been made using a wet-pressing process in which a significant amount of water is removed from a wet-laid web by pressing the web prior to final drying. In one embodiment, for instance, while supported by an absorbent papermaking felt, the web is squeezed between the felt and the surface of a rotating heated cylinder (Yankee dryer) using a pressure roll as the web is transferred to the surface of the Yankee dryer for final drying. The dried web is thereafter dislodged from the Yankee dryer with a doctor blade (creping), which serves to partially debond the dried web by breaking many of the bonds previously formed during the wet-pressing stages of the process. Creping generally improves the softness of the web, albeit at a loss in strength.

Recently, throughdrying has increased in popularity as a means of drying tissue webs. Throughdrying provides a relatively noncompressive method of removing water from the web by passing hot air through the web until it is dry. More specifically, a wet-laid web is transferred to a coarse, highly permeable throughdrying fabric and retained on the throughdrying fabric until it is at least almost completely dry. The resulting dried web can be softer and bulkier than a wet-pressed sheet because fewer papermaking bonds are formed and because the web is less dense. Squeezing water from the wet web is eliminated, although

subsequent transfer of the web to a Yankee dryer for creping is still often used to final dry and/or soften the resulting tissue.

Even more recently, significant advances have been made in high bulk sheets as disclosed in US patents 5,607,551; 5,772,845; 5,656,132; 5,932,068; and 6,171,442, which are all incorporated herein by reference. These patents disclose soft throughdried tissues made without the use of a Yankee dryer.

Even in view of the advances disclosed in the above patents, further improvements are still needed in processes used to produce tissue products, such as bath tissues, facial tissues and paper towels. The present disclosure is generally directed to tissue products having improved properties, especially in the cross-machine direction.

DEFINITIONS

A tissue product as described in this disclosure is meant to include paper products made from base webs such as bath tissues, facial tissues, paper towels, industrial wipers, foodservice wipers, napkins, medical pads, and other similar products.

Pulp fibers, as used herein, include all known cellulosic fibers or fiber mixes comprising cellulosic fibers. Fibers suitable for making the webs of this disclosure comprise any natural cellulosic fibers including, but not limited to nonwoody fibers, such as cotton, abaca, kenaf, sabai grass, flax, esparto grass, straw, jute hemp, bagasse, milkweed floss fibers, and pineapple leaf fibers; and woody fibers such as those obtained from deciduous and coniferous trees, including softwood fibers, such as northern and southern softwood kraft fibers; hardwood fibers, such as eucalyptus, maple, birch, and aspen. Woody fibers can be prepared in high-yield or low-yield forms and can be pulped in any known method, including kraft, sulfite, high-yield pulping methods and other known pulping methods. Fibers prepared from organosolv pulping methods can also be used, including the fibers and methods disclosed in U.S. Patent No. 4,793,898, issued December 27, 1988, to Laamanen et al.; U.S. Patent No. 4,594,130, issued June 10, 1986, to Chang et al.; and U.S. Patent No. 3,585,104. Useful fibers can also be produced by anthraquinone pulping, exemplified by U.S. Patent No. 5,595,628, issued January 21, 1997, to Gordon et al. A portion of the fiber furnish, such as up to 50% or less by dry weight, or from about 5% to about 30% by dry weight, can be synthetic

fibers such as rayon, polyolefin fibers, polyester fibers, bicomponent sheath-core fibers, multi-component binder fibers, and the like. An exemplary polyethylene fiber is Pulpex®, available from Hercules, Inc. (Wilmington, Delaware). Any known bleaching method can be used. Synthetic cellulose fiber types include rayon in all its varieties and other fibers derived from viscose or chemically modified cellulose. Chemically treated natural cellulosic fibers can be used such as mercerized pulps, chemically stiffened or crosslinked fibers, or sulfonated fibers. For good mechanical properties in using papermaking fibers, it can be desirable that the fibers be relatively undamaged and largely unrefined or only lightly refined. While recycled fibers can be used, virgin fibers are generally useful for their mechanical properties and lack of contaminants. Mercerized fibers, regenerated cellulosic fibers, cellulose produced by microbes, rayon, and other cellulosic material or cellulosic derivatives can be used. Suitable papermaking fibers can also include recycled fibers, virgin fibers, or mixes thereof. In certain embodiments capable of high bulk and good compressive properties, the fibers can have a Canadian Standard Freeness of at least 200, more specifically at least 300, more specifically still at least 400, and most specifically at least 500.

Other pulp fibers that can be used in the present disclosure include paper broke or recycled fibers and high yield fibers. High yield pulp fibers are those papermaking fibers produced by pulping processes providing a yield of about 65% or greater, more specifically about 75% or greater, and still more specifically about 75% to about 95%. Yield is the resulting amount of processed fibers expressed as a percentage of the initial wood mass. Such pulping processes include bleached chemithermomechanical pulp (BCTMP), chemithermomechanical pulp (CTMP), pressure/pressure thermomechanical pulp (PTMP), thermomechanical pulp (TMP), thermomechanical chemical pulp (TMCP), high yield sulfite pulps, and high yield Kraft pulps, all of which leave the resulting fibers with high levels of lignin. High yield fibers are well known for their stiffness in both dry and wet states relative to typical chemically pulped fibers.

Tensile Strength, Geometric Mean Tensile Strength (GMT), Tensile Energy Absorbed (TEA), and Percent Stretch:

The tensile test is performed using tissue samples that are conditioned at 23° C +/- 1°C and 50% +/- 2% relative humidity for a minimum of 4 hours. The

samples are cut into 3 inch wide strips in the machine direction (MD) and cross-machine direction (CD) using a precision sample cutter model JDC 15M-10, available from Thwing-Albert Instruments, a business having offices located in Philadelphia, Pennsylvania, U.S.A.

The gauge length of the tensile frame is set to 4 inches. The tensile frame may be an Alliance RT/1 frame run with TestWorks 4 software. The tensile frame and the software are available from MTS Systems Corporation, a business having offices located in Minneapolis, Minnesota, U.S.A.

A 3" strip is then placed in the jaws of the tensile frame and subjected to a strain of 10 inches per minute until the point of sample failure. The stress on the tissue strip is monitored as a function of the strain. The calculated outputs include the peak load (grams-force/3", measured in grams-force), the peak stretch (%), calculated by dividing the elongation of the sample by the original length of the sample and multiplying by 100%), the % stretch @ 500 grams-force, the tensile energy absorption (TEA) at break (grams-force*cm/cm², calculated by integrating or taking the area under the stress-strain curve up to 70% of sample failure), and the slope A (kilograms-force, measured as the slope of the stress-strain curve from 57-150 grams-force).

Each tissue code (minimum of five replicates) is tested in the machine direction (MD) and cross-machine direction (CD). Geometric means of the tensile strength and tensile energy absorption (TEA) are calculated as the square root of the product of the machine direction (MD) and the cross-machine direction (CD). This yields an average value that is independent of testing direction.

Machine Direction Slope A or Cross-Machine Direction Slope A is a measure of the stiffness of a sheet and is also referred to as elastic modulus. The slope of a sample in the machine direction or the cross-machine direction is a measure of the slope of a stress-strain curve of a sheet taken during a test of tensile testing (see tensile strength definition above) and is expressed in units of grams of force. In particular, the slope A is taken as the least squares fit of the data between stress values of 70 grams of force and 157 grams of force.

Cross-Machine Direction Tensile/Cross-Machine Direction Stretch is the amount of tensile strength needed to generate 1% of stretch in the sample in the cross-machine direction. This value is calculated by taking the cross-machine

direction peak load and dividing it by the stretch obtained at 500 grams force or peak load whichever is lower.

Cross-Machine Direction Tensile Energy Absorbed/Cross-Machine Direction Stretch is the amount of tensile energy absorbed needed to create 1% of stretch. This value is calculated by dividing the tensile energy absorbed in the cross-machine direction by the stretch of the sample in the cross-machine direction.

The bulk is calculated as the quotient of the caliper of a dry tissue sheet, expressed in microns, divided by the dry basis weight, expressed in grams per square meter. The resulting sheet bulk is expressed in cubic centimeters per gram. More specifically, the caliper is measured as the total thickness of a stack of ten representative sheets and dividing the total thickness of the stack by ten, where each sheet within the stack is placed with the same side up. Caliper is measured in accordance with TAPPI test method T411 om-89 "Thickness (caliper) of Paper, Paperboard, and Combined Board" with Note 3 for stacked sheets. The micrometer used for carrying out T411 om-89 is an Emveco 200-A Tissue Caliper Tester available from Emveco, Inc., Newberg, Oregon. The micrometer has a load of 2.00 kilo-Pascals (132 grams per square inch), a pressure foot area of 2500 square millimeters, a pressure foot diameter of 56.42 millimeters, a dwell time of 3 seconds and a lowering rate of 0.8 millimeters per second.

SUMMARY OF THE INVENTION

The present disclosure is generally directed to tissue products having enhanced cross-machine directional properties. These properties include relatively high peak stretch, relatively low slope, and increased tensile energy absorbed in the cross-machine direction. Thus, products made according to the present disclosure have relatively low stiffness with increased extensibility at relatively high strength levels.

The present inventors have discovered that the above properties can be obtained particularly on uncreped through-air dried webs. Further, the properties can be obtained without having to apply any bonding materials or binders to the surfaces of the web or to otherwise incorporate such materials into the web. In accordance with the present disclosure, the webs are formed in a through-air drying process in which a transfer fabric and a through-air drying fabric are both textured fabrics having a substantially uniform high strain distribution in the cross-

machine direction. In the past, the transfer fabric tended to be more smooth and less textured than the through-air drying fabric.

In one embodiment, the present disclosure is directed to a single ply tissue product that comprises a tissue web containing pulp fibers. For instance, the tissue web may contain pulp fibers in an amount greater than about 50% by weight, such as in an amount greater than about 90% by weight. The tissue web may have a dry bulk of at least about 3 cc/g, such as at least about 8 cc/g, such as at least about 10 cc/g. In accordance with the present disclosure, the tissue web may have a geometric mean tensile strength of less than about 1,000 g/3 in, such as less than about 900 g/3 in, such as less than about 700 g/3 in. At these strength levels, the tissue web can have a cross-machine direction stretch of greater than about 11%, such as greater than about 13%, such as greater than about 15%. The cross-machine directional slope A of the product can be less than about 3 kg, such as less than about 2.5 kg. The cross-machine direction tensile/cross-machine directional stretch can be less than about 50, such as less than about 30. The cross-machine directional tensile energy absorbed/cross-machine directional stretch, on the other hand, can be less than about 0.4, such as less than about 0.35, such as less than about 0.3.

In one embodiment, the tissue web may comprise an uncreped through-air dried web. For instance, the web may be formed in a wetlaid through-air dried process. During the process, the web can be conveyed on a transfer fabric positioned immediately upstream from a through-air dryer. From the transfer fabric, the web may be transferred to a through-air dryer fabric that is configured to convey the web through the through-air dryer. In order to obtain the above properties, both the transfer fabric and the through-air dryer fabric may comprise textured fabrics having a machine direction dominant design.

For instance, the transfer fabric and the through-air dryer fabric may comprise multi-layered fabrics having from about 5 to about 15 raised elements per centimeter, such as from about 9 to about 11 raised elements per centimeter in the machine direction. The raised elements may have a height of from about 0.3 mm to about 5 mm, such as from about 0.3 mm to about 1 mm, such as from about 0.3 mm to about 0.5 mm. The raised elements may comprise ridges that have a width of from about 0.3 mm to about 1 mm. When viewed in the cross-

machine direction, the ridges may have a sinusoidal ridge frequency of from about 0.5 mm to about 2 mm.

While being conveyed on at least one of the transfer fabric or the through-air dryer fabric, the tissue web may be molded against the fabric which has been found to enhance the properties of the web, especially in the cross-machine direction.

In one embodiment, the tissue product can demonstrate improved properties even in relation to many commercially available two-ply products. For instance, in one embodiment, the tissue product may have a cross-machine directional stretch of greater than about 15%, while having a cross-machine direction tensile/cross-machine direction stretch of less than about 30 and a cross-machine directional TEA/cross-machine directional stretch of less than about 0.4. The tissue product can also have a cross-machine direction slope of less than about 3 kg at geometric mean tensile strengths of less than about 1,000 g/3 in, such as less than about 700 g/3 in, such as less than about 500 g/3 in.

Other features and aspects of the present disclosure are discussed in greater detail below.

BRIEF DESCRIPTION OF THE DRAWINGS

A full and enabling disclosure of the present disclosure, including the best mode thereof to one of ordinary skill in the art, is set forth more particularly in the specification, including reference to the accompanying Figures in which:

Figure 1 is a cross-sectional view of one embodiment of a process for making tissue webs in accordance with the present disclosure; and

Figure 2 is a cross-sectional view in the cross-machine direction of an exemplary illustration showing one embodiment of a transfer fabric that may be used in the process of the present disclosure.

Repeat use of reference characters in the present specification and drawings is intended to represent the same or analogous features or elements of the present disclosure.

DETAILED DESCRIPTION

It is to be understood by one of ordinary skill in the art that the present discussion is a description of exemplary embodiments only, and is not intended as

limiting the broader aspects of the present disclosure, which broader aspects are embodied in the exemplary construction.

In general, the present disclosure is directed to tissue products having a unique combination of properties and to a process for producing the products. More particularly, tissue products made according to the present disclosure have enhanced properties especially in the cross-machine direction or the width direction of the tissue web as it is formed during a tissue making process. Tissue products made according to the present disclosure may comprise single ply products or multiple ply products, such as two-ply products. Such tissue products may include bath tissues and facial tissues. Paper towels, napkins, and other similar products may also be produced.

Tissue webs made according to the present disclosure generally comprise uncreped through-air dried webs. In order to produce the webs with the enhanced properties, the tissue web is conveyed through the through-air drying process using a transfer fabric immediately upstream from a through-air drying fabric in which both fabrics comprise substantially uniform and highly strained fabrics. For instance, the fabrics may have a uniform cross-machine direction strain distribution with from about 5% to about 25% cross-machine direction path-length strain, such as from about 10% to about 20% cross-machine direction path-length strain. In one particular embodiment, for instance, the fabric may have a path-length strain in the cross-machine direction of approximately 15%.

As described above, tissue webs made according to the present disclosure have enhanced properties, especially in the cross-machine direction. For instance, the tissue webs have relatively low stiffness, have increased extensibility and have enhanced durability all in the cross-machine direction.

For example, in one embodiment, a tissue web may be made according to the present disclosure that has, at a geometric mean tensile strength (GMT) of less than about 1,000 g/3 in, such as less than about 700 g/3 in, such as less than about 500 g/3 in, and a cross-machine stretch of at least about 11%, such as at least about 13%, such as at least about 15%. Additionally, the tissue web may have a cross-machine direction tensile strength/cross-machine direction stretch of less than about 50, such as less than about 40, such as less than about 30, which indicates the amount of grams tensile strength in order to obtain 1% of stretch.

The tissue webs may also have a cross-machine direction tensile energy absorbed (TEA)/cross-machine direction stretch of less than about 0.4, such as less than about 0.3. In addition to having improved stretch and strength characteristics in the cross-machine direction, the products also exhibit relatively low stiffness. For instance, the products can have a cross-machine direction slope of less than about 3 kg, such as less than about 2.5 kg.

The basis weight of tissue products made in accordance with the present disclosure can vary depending upon the particular application and whether or not the product is a single ply product or a multiple ply product. For single ply products, for instance, the basis weight of the products can be from about 15 gsm to about 45 gsm. For multiple ply products, on the other hand, the basis weight can be from about 15 gsm to about 50 gsm. As stated above, such products have a geometric mean tensile strength of generally less than about 1,000 g/3 in and are particularly well suited for producing facial tissues and bath tissues. The tissue product may be sold to consumers as a spirally wound product or may be sold to consumers as separately stacked sheets.

The tissue products can also be produced with the above properties while also minimizing the presence of pinholes. The degree to which pinholes are present can be quantified by the Pinhole Coverage Index, the Pinhole Count Index and the Pinhole Size Index, all of which are determined by an optical test method known in the art and described in U.S. Patent Application No. US 2003/0157300 A1 to Burazin, et al. entitled "Wide Wale Tissue Sheets and Method of Making Same", published on August 21, 2003, and which is incorporated herein by reference. More particularly the "Pinhole Coverage Index" is the arithmetic mean percent area of the sample surface area, viewed from above, which is covered or occupied by pinholes. Tissue webs made according to the present disclosure can have a Pinhole Coverage Index of about 0.25 or less, such as from about 0.20 or less, such as from about 0.15 or less, and, in one embodiment, from about 0.05 to about 0.15.

The "Pinhole Count Index" is the number of pinholes per 100 square centimeters that have an equivalent circular diameter (ECD) greater than 400 microns. Webs made according to the present disclosure can have a Pinhole Count Index of about 65 or less, such as about 60 or less, such as about 50 or

less, such as about 40 or less, and, in one embodiment, from about 5 to about 50, such as from about 5 to about 40.

The "Pinhole Size Index" is the mean equivalent circular diameter (ECD) for all pinholes having an ECD greater than 400 microns. For webs made according to the present disclosure, the Pinhole Size Index can be about 600 or less, such as about 500 or less, such as from about 400 to about 600, such as from about 450 to about 550.

Base webs that may be used in the process of the present disclosure can vary depending upon the particular application. For instance, the webs can be made from any suitable type of fiber. For example, the base web can be made from pulp fibers, other natural fibers, synthetic fibers, and the like.

Pulp fibers useful for purposes of this disclosure include any cellulosic fibers which are known to be useful for making tissue products, particularly those fibers useful for making relatively low density webs such as facial tissue, bath tissue, paper towels, dinner napkins and the like. Suitable fibers include virgin softwood and hardwood fibers, as well as secondary or recycled cellulosic fibers, and mixtures thereof. Especially suitable hardwood fibers include eucalyptus and maple fibers. As used herein, secondary fibers means any cellulosic fiber which has previously been isolated from its original matrix via physical, chemical or mechanical means and, further, has been formed into a fiber web, dried to a moisture content of about 10 weight percent or less and subsequently reisolated from its web matrix by some physical, chemical or mechanical means.

Tissue webs made in accordance with the present invention can be made with a homogeneous fiber furnish or can be formed from a stratified fiber furnish producing layers within the single ply product. Stratified base webs can be formed using equipment known in the art, such as a multi-layered headbox. Both strength and softness of the base web can be adjusted as desired through layered tissues, such as those produced from stratified headboxes.

For instance, different fiber furnishes can be used in each layer in order to create a layer with the desired characteristics. For example, layers containing softwood fibers have higher tensile strengths than layers containing hardwood fibers. Hardwood fibers, on the other hand, can increase the softness of the web. In one embodiment, the single ply base web of the present invention includes a

first outer layer and a second outer layer containing primarily hardwood fibers. The hardwood fibers can be mixed, if desired, with paper broke in an amount up to about 30% by weight and/or softwood fibers in an amount up to about 30% by weight. The base web further includes a middle layer positioned in between the first outer layer and the second outer layer. The middle layer can contain primarily softwood fibers. If desired, other fibers, such as high-yield fibers or synthetic fibers may be mixed with the softwood fibers.

When constructing a web from a stratified fiber furnish, the relative weight of each layer can vary depending upon the particular application. For example, in one embodiment, when constructing a web containing three layers, each layer can be from about 15% to about 50% of the total weight of the web, such as from about 25% to about 35% of the weight of the web.

The tissue web can contain pulp fibers and can be formed in a wet-lay process incorporating a through-air dryer. In a wet-lay process, the fiber furnish is combined with water to form an aqueous suspension. The aqueous suspension is spread onto a wire or felt and dried to form the web.

In one embodiment, the base web is formed by an uncreped through-air drying process. More particularly, according to the present disclosure, a textured and highly strained transfer fabric and a similar textured and highly strained through-air drying fabric are used in the process during production of the webs and contributes to the improved and unique properties obtained. Referring to **Figure 1**, a schematic process flow diagram illustrating a method of making uncreped throughdried sheets in accordance with this embodiment is illustrated. Shown is a twin wire former having a papermaking headbox **10** which injects or deposits a stream **11** of an aqueous suspension of papermaking fibers onto the forming fabric **13** which serves to support and carry the newly-formed wet web downstream in the process as the web is partially dewatered to a consistency of about 10 dry weight percent. Specifically, the suspension of fibers is deposited on the forming fabric **13** between a forming roll **14** and another dewatering fabric **12**. Additional dewatering of the wet web can be carried out, such as by vacuum suction, while the wet web is supported by the forming fabric.

The wet web is then transferred from the forming fabric to a transfer fabric **17** traveling at a slower speed than the forming fabric in order to impart increased

stretch into the web. Transfer is preferably carried out with the assistance of a vacuum shoe **18** and a kiss transfer to avoid compression of the wet web. If desired, the web may be transferred against the transfer fabric **17** under sufficient pressure to cause the sheet to conform to the fabric.

The web is then transferred from the transfer fabric to the throughdrying fabric **19** with the aid of a vacuum transfer roll **20** or a vacuum transfer shoe. The throughdrying fabric can be traveling at about the same speed or a different speed relative to the transfer fabric. If desired, the throughdrying fabric can be run at a slower speed to further enhance stretch. Transfer is preferably carried out with vacuum assistance to ensure deformation of the sheet to conform to the throughdrying fabric, thus yielding desired bulk and appearance.

As described above, in accordance with the present disclosure, the process is carried out such that both the transfer fabric **17** and the through-air drying fabric **19** comprise textured fabrics having a substantially uniform cross-machine direction strain distribution. For instance, the fabrics can have a cross-machine direction path-length strain of from about 10% to about 20%, such as from about 14% to about 16%.

Suitable textured or 3-dimensional fabrics that may be used as the transfer fabric and the through-air drying fabric are fabrics that can include a top surface and a bottom surface. During molding and/or through-air drying, the top surface supports the wet tissue web. The wet tissue web conforms to the top surface and during molding is strained into a 3-dimensional topographic form corresponding to the 3-dimensional topography of the top surface of the fabric. Adjacent the bottom surface, the fabric can have a load-bearing layer which integrates the fabric and provides a relatively smooth surface for contact with various tissue machine elements.

The transfer fabric and the through-air drying fabric, for instance, may have textured sheet-contacting surfaces comprising substantially continuous machine-direction ridges separated by valleys (see, for instance, U.S. Patent Application No. 2003/0157300 A1 to Burazin, et al., which is incorporated herein by reference).

For instance, both fabrics can have a machine-direction dominant design comprising from about 5 to about 15 raised elements per centimeter in the machine direction, such as from about 9 to about 11 raised elements per

centimeter. The raised elements may have a height of from about 0.3 mm to about 5 mm, such as from about 0.3 mm to about 1 mm, such as from about 0.3 mm to about 0.5 mm. The raised elements may comprise ridges that have a width of from about 0.3 mm to about 1 mm. A cross-machine direction line trace of the fabric, for instance, may have the approximate structure of a wave, such as a sine wave. For example, referring to **Fig. 2**, for exemplary purposes only, a cross section of a fabric **100** in the cross-machine direction is shown illustrating the structure of a wave. For fabrics used in accordance with the present disclosure, the wave can have an amplitude of from about 0.3 mm to about 0.7 mm, such as about 0.5 mm and a frequency of from about 0.5 mm to about 2 mm, such as about 1 mm.

In one embodiment, both the transfer fabric and the through-air drying fabric may comprise the same fabric or a different but similar fabric. In one particular embodiment, the transfer fabric and the through-air drying fabric comprise the t-1207-6 fabric obtained from Voith Fabrics, Inc.

The use of textured and highly strained fabrics as described above in both the transfer fabric position and the through-air drying fabric position has unexpectedly produced products having a unique combination of properties and improved characteristics, especially in the cross-machine direction. In the past, many conventional processes used a transfer fabric that had a relatively smooth surface (less textured than the throughdrying fabric) in order to impart smoothness to the web. The present inventors, however, have discovered that using a textured and highly strained fabric as described above may provide various benefits and advantages.

The level of vacuum used for the web transfers can be, for instance, from about 3 to about 25 inches of mercury, such as about 6 inches of mercury to about 15 inches of mercury. The vacuum shoe (negative pressure) can be supplemented or replaced by the use of positive pressure from the opposite side of the web to blow the web onto the next fabric in addition to or as a replacement for sucking it onto the next fabric with vacuum. Also, a vacuum roll or rolls can be used to replace the vacuum shoe(s).

While supported by the throughdrying fabric, the web is dried to a consistency of about 94 percent or greater by the throughdryer **21** and thereafter

transferred to a carrier fabric **22**. The dried basesheet **23** is transported to the reel **24** using carrier fabric **22** and an optional carrier fabric **25**. An optional pressurized turning roll **26** can be used to facilitate transfer of the web from carrier fabric **22** to fabric **25**. Suitable carrier fabrics for this purpose are Albany International 84M or 94M and Asten 959 or 937, all of which are relatively smooth fabrics having a fine pattern.

Softening agents, sometimes referred to as debonders, can be used to enhance the softness of the tissue product and such softening agents can be incorporated with the fibers before, during or after formation of the aqueous suspension of fibers. Such agents can also be sprayed or printed onto the web after formation, while wet. Suitable agents include, without limitation, fatty acids, waxes, quaternary ammonium salts, dimethyl dihydrogenated tallow ammonium chloride, quaternary ammonium methyl sulfate, carboxylated polyethylene, cocamide diethanol amine, coco betaine, sodium lauryl sarcosinate, partly ethoxylated quaternary ammonium salt, distearyl dimethyl ammonium chloride, polysiloxanes and the like. Examples of suitable commercially available chemical softening agents include, without limitation, Berocell 596 and 584 (quaternary ammonium compounds) manufactured by Eka Nobel Inc., Adogen 442 (dimethyl dihydrogenated tallow ammonium chloride) manufactured by Sherex Chemical Company, Quasoft 203 (quaternary ammonium salt) manufactured by Quaker Chemical Company, and Arquad 2HT-75 (di (hydrogenated tallow) dimethyl ammonium chloride) manufactured by Akzo Chemical Company. Suitable amounts of softening agents will vary greatly with the species selected and the desired results. Such amounts can be, without limitation, from about 0.05 to about 1 weight percent based on the weight of fiber, more specifically from about 0.25 to about 0.75 weight percent, and still more specifically about 0.5 weight percent.

In order to provide stretch to the tissue in the machine direction, a speed differential may be provided between fabrics at one or more points of transfer of the wet web. This process is known as rush transfer. The speed difference between the fabrics can be from about 5 to about 75 percent or greater, such as from about 10 to about 35 percent. For instance, in one embodiment, the speed difference can be from about 20 to about 30 percent, based on the speed of the slower fabric. The optimum speed differential will depend on a variety of factors,

including the particular type of product being made. As previously mentioned, the increase in stretch imparted to the web is proportional to the speed differential. For a single-ply uncreped throughdried bath tissue having a basis weight of about 30 grams per square meter, for example, a speed differential of from about 20 to about 30 percent between the forming fabric and a transfer fabric produces a stretch in the machine direction in the final product of from about 15 to about 25 percent. The stretch can be imparted to the web using a single differential speed transfer or two or more differential speed transfers of the wet web prior to drying. Hence there can be one or more transfer fabrics. The amount of stretch imparted to the web can hence be divided among one, two, three or more differential speed transfers.

The web is transferred to the throughdrying fabric for final drying preferably with the assistance of vacuum to ensure macroscopic rearrangement of the web to give the desired bulk and appearance.

As described above, webs made according to the process of the present disclosure possess a combination of unique properties especially in the cross-machine direction. It may be possible to obtain these properties by applying a flexible binder to the web as it is produced. As used herein, a "binder" refers to any suitable bonding agent that is applied to a tissue web for bonding the web together and may include materials, such as ethylene vinyl acetate copolymers and the like. The properties of webs made according to the present disclosure, however, are produced without having to apply a binder to either surface of the web.

After the web is formed and dried, the tissue product of the present disclosure may undergo a converting process where the formed base web is prepared for final packaging. For instance, in one embodiment, the tissue web may be spirally wound into rolls to produce, for instance, a bath tissue product. Alternatively, the tissue web may be cut into sheets to serve as a bath tissue product or a facial tissue product. In one embodiment, the tissue web may be combined with another web to produce a two-ply tissue product.

The following example is intended to illustrate particular embodiments of the present disclosure without limiting the scope of the appended claims.

EXAMPLE

An uncreped through-dried bath tissue was produced similar to the process illustrated in **Fig. 1**. In accordance with the present disclosure, the transfer fabric immediately upstream from the through-air dryer and the following through-air dryer fabric were both a t-1207-6 fabric obtained from Voith Fabrics, Inc.

The base web was made of about 28 to 29% Northern Softwood Kraft (NSWK) and about 71 to 72% Kraft eucalyptus, which was layered as follows: 36% eucalyptus / 28% NSWK / 36% eucalyptus by weight.

The eucalyptus was treated with 1.75 kg/mt active debonder and the NSWK was refined between 0 and 2.5 HPD/T with 5 kg/mt of PAREZ wet strength resin added.

The tissue was vacuum dewatered to approximately 26-28% consistency prior to entering the through-air dryer and then dried in the through-air dryer to approximately 1% final moisture prior to winding of the parent rolls.

Eleven different tissue samples made according to the above process were prepared and tested for various properties. Also, numerous bath tissue products obtained world-wide were also tested. The following results were obtained:

Manufacturer	Brand	Sub-Brand	Plies (number)	BD Basis Weight (gsm)	MD-Dry Tensile (gm/76.2mm)	CD-DRY Tensile (gm/76.2mm)	MD/CD Ratio	GMT (gm/76.2mm)
	Sample 1	Code 220	1	28.1	907	284	3.2	507
	Sample 2	Code 4	1	28.3	896	451	2.0	636
	Sample 3	Code 6	1	29.3	1037	565	1.8	766
	Sample 4	Code 219	1	28	812	315	2.6	506
	Sample 5	Code 218	1	27.9	759	350	2.2	516
	Sample 6	Code 64	1	28.1	896	538	1.7	695
	Sample 7	Code 65	1	27.8	883	509	1.7	671
	Sample 8	Code 5	1	28.5	940	480	2.0	672
	Sample 9	Code 66	1	29.2	1198	676	1.8	900
	Sample 10	Code 67	1	29	1157	654	1.8	870
	Sample 11	Code 217	1	27.2	701	387	1.8	521
Kimberly-Clark	Classic		2	30.73	918	391	2.3	599
SCA	Sorbent	Original	2	28.8	1948	467	4.2	954
Kimberly-Clark	Petalo	Sensations	1	31.00	851	605	1.4	718
Melhoramentos	Fofura		2	27.92	906	311	2.9	531
Kimberly-Clark	Lys		2	29.43	886	381	2.3	581
Kimberly-Clark	Cottenelle	Dilbert	1	28.87	670	501	1.3	579
Kimberly-Clark	Scottex	double roll	2	29.30	1487	724	2.1	1038
Kimberly-Clark	Kleenex		1	32.1	984	668	1.5	811
Kimberly-Clark	Kerlisu		2	31.42	1365	567	2.4	880
Kimberly-Clark	Cottenelle	Ironman 1.2	1	27.5	724	489	1.5	595
Kirkland								
GP	Signature		2	30.7	1193	427	2.8	714
P&G	Charmin		1	29.9	671	461	1.5	556
Kimberly-Clark	Kleenex	Printed	2	31.3	1127	496	2.3	748
Kimberly-Clark	Cottenelle	Linea Dorada	2	31.80	1208	931	1.3	1060
P&G	Charmin	Ultra	2	43.1	694	513	1.4	597

Manufacturer	Brand	Sub-Brand	Plies (number)	BD Basis Weight (gsm)	MD-Dry Tensile (gm/76.2mm)	CD-DRY Tensile (gm/76.2mm)	MD/CD Ratio	GMT (gm/76.2mm)
Kimberly-Clark	Popee	Plus	2	31.42	1536	583	2.6	946
	Albert Heijn	mainline	2	36.80	1541	476	3.2	856
P&G	Charmin	Plus	1	35.7	721	515	1.4	609
P&G	Codi		2	26.97	1350	521	2.6	839
Nibong Tebal	Royal Gold		3	44.80	2689	569	4.7	1237
Kimberly-Clark	Cottenelle	Aloe & E	1	33.7	804	632	1.3	713
Kimberly-Clark	Page Good	mainline	1	33.40	1134	956	1.2	1041
Monalisa	Morning		2	28.26	1573	470	3.3	860
GP	Northern		2	33.0	941	398	2.4	612
Papeles								
Nacionales	Joya	Economico	2	28.39	1585	411	3.9	807
Kimberly-Clark	Cottenelle	Ultra	2	44.3	1055	700	1.5	859
Kimberly-Clark	Scottex	mainline	2	30.50	1574	708	2.2	1056
Kimberly-Clark	Fiesta	-	1	20.62	1063	438	2.4	682
Kimberly-Clark	Scottex	mainline	2	37.2	1536	486	3.2	864
Kimberly-Clark	Kleenex		2	32.96	1444	475	3.0	828
	Kirkland							
Kimberly-Clark	Signature Member's	Evt #1	2	30.5	1253	448	2.8	749
Kimberly-Clark	Mark		2	29.2	1302	513	2.5	817
Kimberly-Clark	Carlton	1-Ply	1	17.67	1343	440	3.1	769
Cimic	Hygienix		2	30.83	1538	534	2.9	906
	Kirkland							
Kimberly-Clark	Signature Soft &	Evt #3	2	31.4	1016	471	2.2	692
Metsa / Soffass	Easy		2	30.29	2297	612	3.8	1186
Kimberly-Clark	Tiss Soff		2	28.59	1580	717	2.2	1064

Manufacturer	Brand	Sub-Brand	Plies (number)	BD Basis Weight (gsm)	MD-Dry Tensile (gm/76.2mm)	CD-DRY Tensile (gm/76.2mm)	MD/CD Ratio	GMT (gm/76.2mm)
GP	Angel Soft		2	35.1	1490	454	3.3	822
Nibong Tebal	Cutie	Soft	2	42.41	1967	714	2.8	1185
Berli Jucker								
Cellox	Cellox		2	28.72	1657	579	2.9	979
Kimberly-Clark	WalMart	Great Value	2	28.79	1514	548	2.8	911
Nampak	Twinsaver	1-Ply	1	19.09	1244	558	2.2	833
Copamex	Regio		2	30.10	1242	449	2.8	747
Yung feng yu	Mayflower		2	32.67	2471	539	4.6	1154
Tronchetti	Foxy	Super Soft	2	30.60	1788	650	2.8	1078
Kimberly-Clark	Andrex		2	32.90	1403	622	2.3	934
GP	Walgreen	1000	1	17.7	1139	435	2.6	704
Kimberly-Clark	Velvet		2	34.33	3468	934	3.7	1800
Kimberly-Clark	Scott	Deluxe	2	28.54	1245	524	2.4	808
Delicarta	Aldi Solo	3-ply	3	44.20	2369	598	4.0	1190
Nampak	Twinsoft	2 Ply	2	30.12	1300	639	2.0	911
Kimberly-Clark	Sujay		3	43	2597	847	3.1	1483
Kimberly-Clark	Wondersoft		2	29.5	1088	736	1.5	895
Kimberly-Clark	Scott	Extra	2	33.06	1604	688	2.3	1051
SCA	Sorbent	Extra Thick	3	41.7	2401	720	3.3	1315
Kimberly-Clark	Scottenelle		2	37.6	1387	668	2.1	963
Kimberly-Clark	Scott	Gold	2	29.90	1188	493	2.4	765
Delitissue	Regina		2	39.86	3029	878	3.4	1631
P&G	Charmin	Basic	1	26.43	1198	580	2.1	834
Nibong Tebal	Cutie	Compact	2	38.92	2556	620	4.1	1259
Tien Long								
Paper	Andante		2	33.00	1494	675	2.2	1004

Manufacturer	Brand	Sub-Brand	Plies (number)	BD Basis Weight (gsm)	MD-Dry Tensile (gm/76.2mm)	CD-DRY Tensile (gm/76.2mm)	MD/CD Ratio	GMT (gm/76.2mm)
Papeles								
Nacionales	Suave	Premium Gold	2	38.50	1122	451	2.5	711
Potlatch	Albertson's		1	17.3	1196	527	2.3	794
GP	Colhogar	mainline	2	38.7	1631	515	3.2	916
Kimberly-Clark	Flamingo		2	32.80	1994	535	3.7	1033
Kimberly-Clark	Scott	1-ply	1	17.87	1213	529	2.3	801
P&G	Charmin	Comfort	2	39.7	1600	971	1.6	1246
P&G	Charmin	Suave Aroma	2	33.40	1425	632	2.3	949
Deltissue	Regina		3	44.5	3124	868	3.6	1647
ICT	Foxy	Super Soft	2	34.6	1980	830	2.4	1282
CMPC	Elite	Diseno 2-ply	2	28.13	1094	486	2.3	729
Kimberly-Clark	KleenexSujay		2	33.61	1751	898	1.9	1254
PT Pindo Deli	Paseo		3	43.20	1796	815	2.2	1210
Carrara	Migros Soft	3-ply	3	50.6	2943	948	3.1	1670
Kimberly-Clark	Andrex	POAR	2	41.8	2613	733	3.6	1384
Eroski	Linder	mainline	2	30.5	1608	694	2.3	1056
Kimberly-Clark	Scott	Select	2	27.21	2357	853	2.8	1418
GP	Tenderly	DermaSoft	2	35.80	1393	499	2.8	834
GP	Northern	Ultra	2	39.3	1072	429	2.5	678
Copamex	Flen		2	28.16	2651	821	3.2	1475
	Dollar							
	General		2	32.8	1515	688	2.2	1021
Kimberly-Clark	Kleenex	Care	2	31.50	2091	683	3.1	1195
Sano	SanoSoft		2	30.53	1836	893	2.1	1280
	Clean & Soft	International	3	36.70	2465	861	2.9	1457

Manufacturer	Brand	Sub-Brand	Plies (number)	BD Basis Weight (gsm)	MD-Dry Tensile (gm/76.2mm)	CD-DRY Tensile (gm/76.2mm)	MD/CD Ratio	GMT (gm/76.2mm)
Kimberly-Clark	Andrex	mainline	2	44.1	1945	651	3.0	1125
		Plus Mas Metros						
Kimberly-Clark	Scott		2	27.21	1334	667	2.0	943
Kimberly-Clark	Scott	Natural	2	28.4	1335	669	2.0	945
Kimberly-Clark	Neve	Neutro	2	28.21	1937	731	2.6	1190
Kimberly-Clark	Sujay		2	34.33	1159	721	1.6	914
Kimberly-Clark	Scott	Extra	2	29.01	1925	832	2.3	1266
DaeHan Pulp	K-Nara		2	28.49	1537	736	2.1	1064
Kimberly-Clark	Tiss	-	2	30.94	1818	850	2.1	1243
	Coop Italia	mainline	2	31.50	2208	748	3.0	1285
Kimberly-Clark	Kleenex	Care	2	32.80	1286	766	1.7	993
Santher	Personal	1-ply	1	19.64	1785	913	2.0	1277
Santher	Personal	Premium	2	26.59	1408	670	2.1	971
P&G	Charmin	Comfort	2	42.00	2107	1217	1.7	1601
Kimberly-Clark	Molett		2	31.54	1740	832	2.1	1203
Kimberly-Clark	Kleenex	Baby Soft	2	30.03	1584	725	2.2	1072
P&G	Charmin		2	34.20	1322	684	1.9	951
Kimberly-Clark	Delsey		2	28.67	1713	776	2.2	1153
Kimberly-Clark	Kleenex	Boutique	2	37.45	1233	598	2.1	859
ABC Tissue								
Products	Quilton		3	49.5	2014	781	2.6	1254
Kimberly-Clark	Neve	Elegance	2	29.63	1751	765	2.3	1157
Papeles								
Nacionales	Suave		2	38.70	1346	592	2.3	893
Irving	Soft Weve		1	15.4	1264	498	2.5	793
Kimberly-Clark	Andrex	Ultra (for HK)	3	42.73	1729	841	2.1	1206

				BD															
Manufacturer	Brand	Sub-Brand	Plies (number)	Basis Weight (gsm)	MD-Dry Tensile (gm/76.2mm)	CD-DRY Tensile (gm/76.2mm)	MD/CD Ratio	GMT (gm/76.2mm)											
Kimberly-Clark	Suavel		2	28.08	1614	834	1.9	1160											
	ASDA																		
SCA	Shades		2	34.1	2461	1089	2.3	1637											
Familia Sancela	Familia	Ultra Suave	2	30.24	1278	593	2.2	871											
Familia Sancela	Familia	Economico	2	32.45	1729	766	2.3	1151											
Kimberly-Clark	Kleenex	Ultra Care	3	44.10	1515	897	1.7	1166											
CMPC	Elite	Extra	2	28.43	1919	1211	1.6	1524											
Kimberly-Clark	Nice	1-ply	1	20.03	1354	542	2.5	857											
Kimberly-Clark	Scott	Deluxe	3	46.13	1865	913	2.0	1305											
GP	Tesco	mainline	2	43.5	1823	743	2.5	1164											
Melhoramentos	Sublime		1	19.07	727	480	1.5	591											
	Carrefour	Classic	2	29.40	3135	940	3.3	1717											
SCA	Carrefour	mainline	2	38.7	2586	876	3.0	1505											
Kimberly-Clark	Servus	3-ply	3	46.50	3020	1179	2.6	1887											
Kimberly-Clark	Fancy		2	31.08	1690	743	2.3	1121											
Kimberly-Clark	Scott	1000	1	16.8	1326	581	2.3	878											
Copamex	Lady Regio		2	30.60	1861	963	1.9	1339											
P&G	Tender		2	33.06	1841	710	2.6	1143											
Kimberly-Clark	Hakle Kamille	3-ply	3	48.50	3506	1264	2.8	2105											
	Coop Super																		
	Soft		4	59.8	3821	1269	3.0	2202											
	Clean & Soft	C & S	3	39.40	3225	947	3.4	1748											
Kimberly-Clark	Lily		2	35.03	1724	901	1.9	1246											
Delicarta	AS Schlecker	Premium	4	56.30	2144	1142	1.9	1565											
Kimberly-Clark	Petalo	Classico	2	29.50	2020	940	2.1	1378											
		(Bahrain tissue)																	
Kimberly-Clark	Kleenex		2	30.8	1225	674	1.8	909											

Manufacturer	Brand	Sub-Brand	Plies (number)	BD Basis Weight (gsm)	MD-Dry Tensile (gm/76.2mm)	CD-DRY Tensile (gm/76.2mm)	MD/CD Ratio	GMT (gm/76.2mm)
Familia Sancela	Familia	Cuidado	2	39.69	1243	681	1.8	920
Kimberly-Clark	Scott	Gold	2	28.10	1219	770	1.6	969
	Denner		4	56.4	3389	1248	2.7	2057
Marcal	Marcal		1	16.9	1284	567	2.3	853
Yuen Foong Yu	Mayflower		2	31.3	2019	796	2.5	1268
Kimberly-Clark	Nice	Gold	2	27.01	2302	774	3.0	1335
APP group	Virjoy	2-ply	2	33.98	2885	1009	2.9	1706
APP group	Virjoy	Premium	3	42.30	2095	913	2.3	1383
Productos								
Tissue del Peru	Noble	1-ply	1	19.49	1404	1304	1.1	1353
Kimberly-Clark	Suave	Extra	1	21.11	1230	825	1.5	1007
Kimberly-Clark	Scott	Gold Ultra	3	41.50	1633	1137	1.4	1363
CMPC	Elite	Doble Hoja	2	27.47	2181	977	2.2	1460
Kimberly-Clark	Hakle Kamille	3-ply	3	47.7	3734	1560	2.4	2414
GP	Zewa Lind	3-ply	3	48.70	2901	1008	2.9	1710
SCA	Edet	Friendly	3	44.30	3117	1146	2.7	1890
Kimberly-Clark	Suave	Plus	2	28.66	1529	1004	1.5	1239
Kimberly-Clark	Kleenex	500	2	28.41	2074	701	3.0	1206
Metsa	Lambi		3	44.8	2597	1407	1.8	1912
CMPC	Elite	1-ply	1	18.59	1344	867	1.6	1079
Kimberly-Clark	Suave	Gold	2	29.6	1486	917	1.6	1167
GP	Lotus	Finesse	2	38.50	2155	870	2.5	1369
LIDL	Siempre		4	60.90	4058	1481	2.7	2452
CMPC	Elite	Premium	3	40	2759	1054	2.6	1705
	Vinda	regular	3	38.70	3147	948	3.3	1727
	Migros Soft	Extra	4	56.7	3379	1431	2.4	2199
Soffass	Regina	Rotolini	2	31.80	2013	986	2.0	1409

Manufacturer	Brand	Sub-Brand	Plies (number)	BD Basis Weight (gsm)	MD-Dry Tensile (gm/76.2mm)	CD-DRY Tensile (gm/76.2mm)	MD/CD Ratio	GMT (gm/76.2mm)
APP group	Virjoy	Extra Soft	3	41.90	2221	1057	2.1	1532
	Favorita	Plus	2	28.7	2065	868	2.4	1339
SCA	Velvet		2	43.4	2311	898	2.6	1441
Soffass	Regina	Cartacomomilla	4	59.20	3117	1366	2.3	2063
CMPC	Elite	con Oso	2	27.7	2302	992	2.3	1511
	Vinda	premium	3	40.40	3162	964	3.3	1746
Vinda	Vinda blue		3	40.02	3080	1042	3.0	1791
	Aldi Kokett		4	58.10	3238	1306	2.5	2056
Kimberly-Clark Familia	Vogue		2	28.87	2156	923	2.3	1411
Sancela	Familia	Cuidado	2	39.80	910	1023	0.9	965
San Francisco	Hortensia		2	28.34	2405	1573	1.5	1945

Manufacturer	Brand	Sub-Brand	Plies (number)	MD-Dry Stretch (%)	CD-DRY Stretch (%)	MD-Dry Slope (kg)	CD-DRY Slope (kg)	MD-Dry TEA (gm-cm/cm2)	CD-DRY TEA (gm-cm/cm2)
	Sample 1	Code 220	1	15.3	13.63	6.13	1.92	10.53	3.34
	Sample 2	Code 4	1	16.7	14.6	6.08	2.19	11.48	4.94
	Sample 3	Code 6	1	18.8	16.3	15.2	2.2	18.8	6.22
	Sample 4	Code 219	1	14.54	12.8	6.28	2.2	9.16	3.46
	Sample 5	Code 218	1	13.72	12.64	6.07	2.32	8.58	3.65
	Sample 6	Code 64	1	17.6	15	5.74	2.35	12.6	5.36
	Sample 7	Code 65	1	17	14.5	6.38	2.35	12	5.12
	Sample 8	Code 5	1	15.6	14.4	11.6	2.4	15.6	5.01
	Sample 9	Code 66	1	18.3	15.4	6.79	2.44	16.5	6.6
	Sample 10	Code 67	1	17.5	14.7	8.13	2.55	15.6	6.5
	Sample 11	Code 217	1	13.92	11.91	5.97	2.6	8.23	3.75
Kimberly-Clark	Classic		2	16.95	12.87	5.66	3.19	13.08	6.62
SCA	Sorbent	Original	2	15.18	14.76	7.85	4.00	21.40	9.35
Kimberly-Clark	Petalo	Sensations	1	16.34	10.30	4.67	4.04	9.85	4.45
Melhoramentos	Fofura		2	9.06	7.45	8.13	5.03	6.97	3.03
Kimberly-Clark	Lys		2	11.41	8.75	6.63	5.08	8.93	4.60
Kimberly-Clark	Cottenelle	Dilbert	1	13.23	8.24	8.31	5.16	5.45	4.18
Kimberly-Clark	Scottex	double roll	2	14.29	11.92	10.25	5.21	16.34	8.28
Kimberly-Clark	Kleenex		1	16.18	8.80	4.19	5.87	11.07	4.87
Kimberly-Clark	Kerlisu		2	18.73	9.02	6.35	6.20	21.19	5.95
Kimberly-Clark	Cottenelle	Ironman 1.2	1	13.20	7.19	5.38	6.39	8.32	3.88
GP	Kirkland		2	23.38	9.24	6.25	6.41	22.50	5.28
P&G	Signature		1	22.78	8.55	3.32	6.70	12.53	4.53
Kimberly-Clark	Charmin	Printed	2	23.02	7.51	5.34	6.91	18.75	4.13
Kimberly-Clark	Kleenex								

Manufacturer	Brand	Sub-Brand	Plies (number)	MD-Dry Stretch (%)	CD-DRY Stretch (%)	MD-Dry Slope (kg)	CD-DRY Slope (kg)	MD-Dry TEA (gm-cm/cm2)	CD-DRY TEA (gm-cm/cm2)
Kimberly-Clark	Cottenelle	Linea Dorada	2	17.30	10.14	7.53	6.94	17.55	9.35
P&G	Charmin	Ultra	2	17.91	9.69	5.49	7.35	12.27	6.05
Kimberly-Clark	Popee	Plus	2	20.82	9.27	6.76	7.52	23.86	5.88
	Albert Heijn	mainline	2	11.27	7.85	12.81	7.56	14.15	4.46
P&G	Charmin	Plus	1	23.85	8.71	3.09	7.75	14.14	5.45
P&G	Codi		2	11.34	7.76	9.26	7.91	14.53	5.01
Nibong Tebal	Royal Gold		3	30.01	8.88	9.23	7.94	57.19	7.40
Kimberly-Clark	Cottenelle	Aloe & E	1	13.43	7.42	6.44	7.94	9.52	4.72
Kimberly-Clark	Page Good	mainline	1	20.85	8.19	6.01	7.95	18.33	6.62
Monalisa	Morning		2	22.00	8.37	7.88	8.01	25.77	5.52
GP	Northern		2	17.65	6.85	6.74	8.07	15.11	3.98
Papeles Nacionales	Joya	Economico	2	6.58	6.79	24.93	8.13	9.51	4.14
Kimberly-Clark	Cottenelle	Ultra	2	10.66	8.40	10.36	8.14	10.94	6.15
Kimberly-Clark	Scottex	mainline	2	11.14	9.52	11.93	8.21	14.13	7.99
Kimberly-Clark	Fiesta	-	1	16.29	5.40	4.60	8.22	11.25	3.39
Kimberly-Clark	Scottex	mainline	2	13.03	6.83	8.71	8.26	16.22	4.56
Kimberly-Clark	Kleenex		2	29.00	7.46	6.44	8.32	32.80	5.11
Kimberly-Clark	Kirkland								
Kimberly-Clark	Signature Member's	Evt #1	2	29.04	6.99	5.20	8.36	26.18	4.34
Kimberly-Clark	Mark		2	18.04	6.64	7.22	8.37	18.32	4.08
Kimberly-Clark	Carlton	1-Ply	1	14.25	6.69	11.03	8.40	15.91	3.86
Cimic	Hygienix		2	13.85	5.72	8.04	8.48	16.08	3.89
Kimberly-Clark	Kirkland								
Kimberly-Clark	Signature	Evt #3	2	25.24	6.87	4.69	8.49	19.53	4.22

Manufacturer	Brand	Sub-Brand	Plies (number)	MD-Dry Stretch (%)	CD-DRY Stretch (%)	MD-Dry Slope (kg)	CD-DRY Slope (kg)	MD-Dry TEA (gm-cm/cm2)	CD-DRY TEA (gm-cm/cm2)
Metsa / Soffass	Soft & Easy		2	14.11	8.67	10.34	8.51	24.26	6.59
Kimberly-Clark	Tiss Soff		2	21.03	8.29	6.35	8.52	22.97	6.03
GP	Angel Soft		2	16.14	7.39	11.44	8.61	22.70	4.89
Nibong Tebal	Cutie	Soft	2	27.54	8.59	5.29	8.73	48.26	6.79
Berli Jucker									
Cellox	Cellox		2	16.67	6.63	7.02	8.85	18.33	4.84
Kimberly-Clark	Walmart	Great Value	2	12.98	8.03	8.94	8.94	15.19	5.98
Nampak	Twinsaver	1-Ply	1	13.68	7.09	7.82	8.97	13.58	4.52
Copamex	Regio		2	12.84	6.21	9.09	9.04	14.58	4.23
Yung feng yu	Mayflower		2	13.49	6.69	13.20	9.13	26.39	4.89
Tronchetti	Foxy	Super Soft	2	15.36	7.91	8.15	9.31	18.70	6.60
Kimberly-Clark	Andrex		2	19.54	6.76	6.29	9.57	19.00	5.20
GP	Walgreen	1000	1	11.94	5.36	10.35	9.67	10.94	3.41
Kimberly-Clark	Velvet		2	21.72	9.34	9.58	9.72	56.84	10.39
Kimberly-Clark	Scott	Deluxe	2	13.33	5.99	6.36	9.72	11.10	3.64
Delicarta	Aldi Solo	3-ply	3	12.19	6.85	12.72	9.96	21.31	5.72
Nampak	Twinsoft	2 Ply	2	11.63	6.25	9.08	9.97	14.16	5.08
Kimberly-Clark	Sujay		3	23.75	8.78	8.82	10.04	40.77	8.14
Kimberly-Clark	Wondersoft		2	29.19	7.74	3.49	10.09	22.09	7.27
Kimberly-Clark	Scott	Extra	2	22.94	7.88	4.41	10.10	24.40	7.16
SCA	Sorbent	Extra Thick	3	17.32	7.87	8.54	10.11	26.03	6.12
Kimberly-Clark	Scottenelle		2	7.10	6.40	11.62	10.30	8.51	5.35
Kimberly-Clark	Scott	Gold	2	14.20	4.99	7.96	10.31	12.99	3.04
Deliftissue	Regina		2	16.20	8.34	10.12	10.33	31.81	8.47
P&G	Charmin	Basic	1	25.48	5.78	11.29	10.36	18.47	3.95
Nibong Tebal	Cutie	Compact	2	20.67	7.40	11.01	10.40	36.25	5.69
Tien Long									
Paper	Andante		2	18.32	6.48	5.85	10.65	19.97	5.40

Manufacturer	Brand	Sub-Brand	Plies (number)	MD-Dry Stretch (%)	CD-DRY Stretch (%)	MD-Dry Slope (kg)	CD-DRY Slope (kg)	MD-Dry TEA (gm-cm/cm2)	CD-DRY TEA (gm-cm/cm2)
Papeles Nacionales	Suave	Premium Gold	2	20.16	5.09	6.43	10.67	18.46	3.45
Potlatch	Albertson's		1	17.19	6.00	9.76	10.81	17.78	4.57
GP	Colhogar	mainline	2	15.27	5.70	8.63	10.81	18.13	4.95
Kimberly-Clark	Flamingo		2	12.48	6.82	12.29	10.95	19.21	5.01
Kimberly-Clark	Scott	1-ply	1	17.56	5.76	7.30	10.98	15.38	3.66
P&G	Charmin	Comfort	2	20.49	8.85	9.05	11.16	27.39	9.45
		Suave							
P&G	Charmin	Aroma	2	18.21	6.12	7.96	11.18	21.05	5.35
Deltissue	Regina		3	15.50	9.03	12.25	11.37	32.18	10.21
ICT	Foxy	Super Soft	2	21.38	8.40	9.35	11.47	31.45	7.82
		Diseno 2-ply							
CMPC	Elite		2	9.99	4.47	11.71	11.47	10.49	3.52
Kimberly-Clark	KleenexSujay		2	23.38	6.76	6.65	11.56	29.63	6.03
PT Pindo Deli	Paseo		3	22.19	7.90	6.97	11.63	31.39	7.78
Carrara	Migros Soft	3-ply	3	18.10	8.82	12.60	11.65	38.70	10.49
Kimberly-Clark	Andrex	POAR	2	15.00	6.86	7.46	11.82	21.79	6.35
Eroski	Linder	mainline	2	11.55	5.63	10.65	11.90	16.16	4.28
Kimberly-Clark	Scott	Select	2	20.81	7.21	7.39	11.96	29.35	6.44
GP	Tenderly	DermaSoft	2	16.90	5.38	8.14	12.07	19.39	4.80
GP	Northern	Ultra	2	20.18	4.88	6.98	12.07	19.23	3.49
Copamex	Flen		2	13.86	6.91	12.16	12.13	26.85	6.58
	Dollar								
	General		2	14.79	6.98	11.26	12.27	21.36	7.25
Kimberly-Clark	Kleenex	Care	2	13.91	6.03	13.96	12.35	22.91	5.11
Sano	SanoSoft		2	14.88	7.37	10.29	12.37	24.45	8.42
	Clean & Soft	International	3	22.69	7.31	9.41	12.50	47.12	8.81
Kimberly-Clark	Andrex	mainline	2	21.68	6.86	5.80	12.54	25.90	5.81

Manufacturer	Brand	Sub-Brand	Plies (number)	MD-Dry Stretch (%)	CD-DRY Stretch (%)	MD-Dry Slope (kg)	CD-DRY Slope (kg)	MD-Dry TEA (gm-cm/cm2)	CD-DRY TEA (gm/cm/cm2)
Kimberly-Clark	Scott	Plus Mas Metros	2	9.19	6.24	15.73	12.60	10.82	4.71
Kimberly-Clark	Scott	Natural	2	14.40	5.96	8.30	12.82	15.09	4.85
Kimberly-Clark	Neve	Neutro	2	20.28	7.52	8.80	12.83	28.06	6.06
Kimberly-Clark	Sujay		2	15.22	5.88	5.68	12.93	13.73	4.60
Kimberly-Clark	Scott	Extra	2	19.70	7.19	7.41	13.02	26.79	7.12
DaeHan Pulp	K-Nara		2	13.30	6.04	13.86	13.14	18.57	4.89
Kimberly-Clark	Tiss	-	2	16.37	5.52	7.25	13.39	20.03	5.30
	Coop Italia	mainline	2	12.58	5.22	11.29	13.54	21.36	4.76
Kimberly-Clark	Kleenex	Care	2	19.26	5.70	6.88	13.83	17.53	4.54
Santher	Personal	1-ply	1	17.50	6.20	11.45	13.93	24.45	5.57
Santher	Personal	Premium	2	21.47	5.01	6.74	14.04	23.90	4.25
P&G	Charmin	Comfort	2	18.46	8.93	8.03	14.06	27.35	11.72
Kimberly-Clark	Molett		2	16.98	6.49	9.38	14.25	25.22	6.11
Kimberly-Clark	Kleenex	Baby Soft	2	18.64	5.43	7.73	14.50	22.65	4.74
P&G	Charmin		2	17.29	5.59	7.55	14.53	18.11	5.22
Kimberly-Clark	Delsey		2	14.86	6.68	10.66	14.57	11.21	6.90
Kimberly-Clark	Kleenex	Boutique	2	15.30	4.68	7.07	14.57	14.27	3.62
ABC Tissue									
Products	Quilton		3	16.89	6.89	10.77	14.67	27.95	7.25
Kimberly-Clark	Neve	Elegance	2	20.96	5.74	7.06	14.68	26.64	4.69
Papeles									
Nacionales	Suave		2	23.15	4.91	6.63	14.68	23.42	3.97
Irving	Soft Weve		1	16.69	4.56	11.70	14.73	16.87	3.18
Kimberly-Clark	Andrex	Ultra (for HK)	3	10.70	5.71	12.75	14.76	16.54	5.36
Kimberly-Clark	Suavel		2	17.87	6.71	8.72	14.89	22.83	7.47

Manufacturer	Brand	Sub-Brand	Plies (number)	MD-Dry Stretch (%)	CD-DRY Stretch (%)	MD-Dry Slope (kg)	CD-DRY Slope (kg)	MD-Dry TEA (gm-cm/cm2)	CD-DRY TEA (gm-cm/cm2)
SCA	ASDA		2	11.29	6.63	12.69	14.93	19.52	8.77
Familia	Shades	Ultra							
Sancela	Familia	Suave	2	14.65	4.28	8.06	15.16	14.76	3.48
Familia									
Sancela	Familia	Economico	2	15.73	5.11	11.60	15.18	21.75	4.49
Kimberly-Clark	Kleenex	Ultra Care	3	10.75	6.36	11.29	15.22	17.56	6.14
CMPC	Elite	Extra	2	12.99	6.99	11.92	15.38	20.46	8.32
Kimberly-Clark	Nice	1-ply	1	17.95	3.65	7.08	15.39	17.74	2.13
Kimberly-Clark	Scott	Deluxe	3	12.77	5.84	9.27	15.60	19.28	6.30
GP	Tesco	mainline	2	33.37	7.21	5.37	15.69	40.55	7.53
Melhoramentos	Sublime		1	11.67	3.47	6.08	15.69	6.91	1.95
	Carrefour	Classic	2	10.46	5.79	15.83	15.80	21.79	6.82
SCA	Carrefour	mainline	2	12.26	5.64	18.05	15.89	23.83	5.72
Kimberly-Clark	Servus	3-ply	3	13.25	7.19	15.31	15.92	29.96	9.64
Kimberly-Clark	Fancy		2	16.67	5.44	7.37	15.98	19.97	5.51
Kimberly-Clark	Scott	1000	1	18.50	5.15	9.00	16.01	18.68	4.32
Copamex	Lady Regio		2	21.36	6.73	9.94	16.02	31.53	7.35
P&G	Tender		2	14.64	4.27	7.79	16.06	18.58	4.14
Kimberly-Clark	Hakle Kamille	3-ply	3	19.31	7.61	10.38	16.08	44.14	10.93
	Coop Super								
	Soft		4	13.80	7.07	16.27	16.13	37.32	11.54
	Clean & Soft	C & S	3	32.53	6.32	10.49	16.18	76.19	9.08
Kimberly-Clark	Lily		2	25.06	5.82	5.29	16.20	26.40	5.52
Delicarta	AS Schlecker	Premium	4	12.45	7.68	13.46	16.34	21.85	10.50
Kimberly-Clark	Petalo	Classico (Bahrain tissue)	2	14.19	5.08	13.85	16.36	25.39	5.38
Kimberly-Clark	Kleenex		2	31.08	6.55	6.77	16.52	33.50	5.88

Manufacturer	Brand	Sub-Brand	Plies (number)	MD-Dry Stretch (%)	CD-DRY Stretch (%)	MD-Dry Slope (kg)	CD-DRY Slope (kg)	MD-Dry TEA (gm-cm/cm2)	CD-DRY TEA (gm/cm/cm2)
Familia									
Sancela	Familia	Cuidado	2	17.04	3.84	7.42	16.63	15.62	3.01
Kimberly-Clark	Scott	Gold	2	19.26	4.47	5.93	16.77	15.86	4.11
	Denner		4	10.08	7.57	19.79	17.40	26.26	12.53
Marcal	Marcal		1	12.30	4.00	13.75	17.42	13.68	2.96
Yuen Foong Yu	Mayflower		2	19.69	5.52	8.74	17.54	28.41	5.59
Kimberly-Clark	Nice	Gold	2	17.73	4.15	9.59	17.54	30.72	4.10
APP group	Virjoy	2-ply	2	18.14	5.35	8.42	17.55	35.26	7.41
APP group	Virjoy	Premium	3	31.49	6.61	7.41	17.73	48.27	8.54
Productos									
Tissue del Peru	Noble	1-ply	1	10.79	5.27	10.57	17.75	13.37	5.91
Kimberly-Clark	Suave	Extra	1	13.41	4.22	8.23	18.01	12.89	3.48
Kimberly-Clark	Scott	Gold Ultra	3	10.48	5.39	12.55	18.13	18.82	7.01
CMPC	Elite	Doble Hoja	2	14.84	5.74	10.34	18.44	22.08	6.05
Kimberly-Clark	Hakle Kamille	3-ply	3	18.40	7.33	11.70	18.55	54.35	12.15
GP	Zewa Lind	3-ply	3	14.77	7.19	16.72	18.72	34.75	11.52
SCA	Edet	Friendly	3	20.50	7.14	13.50	18.72	47.17	12.27
Kimberly-Clark	Suave	Plus	2	12.82	5.07	11.43	19.53	16.57	5.55
Kimberly-Clark	Kleenex	500	2	16.55	4.81	16.64	19.64	29.64	5.56
Metsa	Lambi		3	21.24	6.51	13.43	19.95	44.07	10.46
CMPC	Elite	1-ply	1	11.55	3.96	9.13	20.08	13.06	4.00
Kimberly-Clark	Suave	Gold	2	19.09	4.55	8.18	20.15	21.09	4.33
GP	Lotus	Finesse	2	21.14	5.84	9.18	20.41	34.26	7.02
LIDL	Siempre		4	14.78	6.76	16.23	20.86	43.49	12.55
CMPC	Elite	Premium	3	18.49	5.57	10.37	21.04	35.01	7.05
	Vinda	regular	3	22.87	5.07	11.78	21.06	46.72	7.71
	Migros Soft	Extra	4	12.96	6.70	18.78	21.12	36.21	13.00

Manufacturer	Brand	Sub-Brand	Plies (number)	MD- Dry Stretch (%)	CD- DRY Stretch (%)	MD-Dry Slope (kg)	CD-DRY Slope (kg)	MD-Dry TEA (gm-cm/cm2)	CD-DRY TEA (gm/cm/cm2)
Soffass	Regina	Rotolini	2	14.42	4.96	16.69	21.67	26.76	6.97
APP group	Virjoy	Extra Soft	3	23.02	5.47	10.33	22.15	40.07	8.45
	Favorita	Plus	2	12.87	4.18	9.05	22.27	19.68	4.85
SCA	Velvet		2	26.31	4.66	5.79	22.41	31.74	5.69
Soffass	Regina	Cartacomomilla	4	11.61	5.75	22.30	23.01	33.22	9.89
CMPC	Elite	con Oso	2	19.84	5.20	9.95	23.50	30.67	6.24
	Vinda	premium	3	21.63	5.80	14.92	23.55	48.54	8.19
Vinda	Vinda blue		3	19.57	4.64	16.04	24.65	45.74	7.74
	Aldi Kokett		4	17.35	6.72	21.09	26.03	48.02	11.60
Kimberly-Clark	Vogue		2	11.11	4.25	30.50	27.18	23.95	5.31
Familia									
Sancela	Familia	Cuidado	2	14.37	2.97	7.55	28.82	13.66	3.29
San Francisco	Hortensia		2	16.96	3.90	14.02	48.80	33.76	8.02

Manufacturer	Brand	Sub-Brand	Plies (number)	CDT/CD Stretch	CDT/CD TEA	CDTEA/CDS
	Sample 1	Code 220	1	20.8	85.0	0.245
	Sample 2	Code 4	1	30.9	91.3	0.338
	Sample 3	Code 6	1	34.7	90.8	0.382
	Sample 4	Code 219	1	24.6	91.0	0.270
	Sample 5	Code 218	1	27.7	95.9	0.289
	Sample 6	Code 64	1	35.9	100.4	0.357
	Sample 7	Code 65	1	35.1	99.4	0.353
	Sample 8	Code 5	1	33.3	95.8	0.348
	Sample 9	Code 66	1	43.9	102.4	0.429
	Sample 10	Code 67	1	44.5	100.6	0.442
	Sample 11	Code 217	1	32.5	103.2	0.315
Kimberly-Clark	Classic		2	30.4	59.1	0.514
SCA	Sorbent	Original	2	31.6	49.9	0.633
Kimberly-Clark	Petalo	Sensations	1	58.7	136.0	0.432
Melhoramentos	Fofura		2	41.7	102.6	0.407
Kimberly-Clark	Lys		2	43.5	82.8	0.526
Kimberly-Clark	Cottenelle	Dilbert	1	60.8	119.9	0.507
Kimberly-Clark	Scottex	double roll	2	60.7	87.4	0.695
Kimberly-Clark	Kleenex		1	75.9	137.2	0.553
Kimberly-Clark	Kerlisu		2	62.9	95.3	0.660
Kimberly-Clark	Cottenelle	Ironman 1.2	1	68.0	126.0	0.540
GP	Kirkland		2	46.2	80.9	0.571
P&G	Signature		1	53.9	101.8	0.530
Kimberly-Clark	Charmin	Printed	2	66.0	120.1	0.550
Kimberly-Clark	Kleenex	Linea Dorada	2	91.8	99.6	0.922
Kimberly-Clark	Cottenelle	Ultra	2	52.9	84.8	0.624

Manufacturer	Brand	Sub-Brand	Plies (number)	CDT/CD Stretch	CDT/CD TEA	CDTEA/CDS
Kimberly-Clark	Popee	Plus	2	62.9	99.1	0.634
	Albert Heijn	mainline	2	60.6	106.7	0.568
P&G	Charmin	Plus	1	59.1	94.5	0.626
P&G	Codi		2	67.1	104.0	0.646
Nibong Tebal	Royal Gold		3	64.1	76.9	0.833
Kimberly-Clark	Cottenelle	Aloe & E	1	85.2	133.9	0.636
Kimberly-Clark	Page	mainline	1	116.7	144.4	0.808
Monalisa	Good Morning		2	56.2	85.1	0.659
GP	Northern		2	58.1	100.0	0.581
Papeles Nacionales	Joya	Economico	2	60.5	99.3	0.610
Kimberly-Clark	Cottenelle	Ultra	2	83.3	113.8	0.732
Kimberly-Clark	Scottex	mainline	2	74.4	88.6	0.839
Kimberly-Clark	Fiesta	-	1	81.1	129.2	0.628
Kimberly-Clark	Scottex	mainline	2	71.2	106.6	0.668
Kimberly-Clark	Kleenex		2	63.7	93.0	0.685
	Kirkland					
Kimberly-Clark	Signature	Evt #1	2	64.1	103.2	0.621
	Member's					
Kimberly-Clark	Mark		2	77.3	125.7	0.614
Kimberly-Clark	Carlton	1-Ply	1	65.8	114.0	0.577
Cimic	Hygienix		2	93.4	137.3	0.680
	Kirkland					
Kimberly-Clark	Signature	Evt #3	2	68.6	111.6	0.614
Metsa / Soffass	Soft & Easy		2	70.6	92.9	0.760
Kimberly-Clark	Tiss Soft		2	86.5	118.9	0.727
GP	Angel Soft		2	61.4	92.8	0.662
Nibong Tebal	Cutie	Soft	2	83.1	105.2	0.790

Manufacturer	Brand	Sub-Brand	Plies (number)	CDT/CD Stretch	CDT/CD TEA	CDTEA/CDS
Berli Jucker Cellox	Cellox		2	87.3	119.6	0.730
Kimberly-Clark	WalMart	Great Value	2	68.2	91.6	0.745
Nampak	Twinsaver	1-Ply	1	78.7	123.5	0.638
Copamex	Regio		2	72.3	106.1	0.681
Yung feng yu	Mayflower		2	80.6	110.2	0.731
Tronchetti	Foxy	Super Soft	2	82.2	98.5	0.834
Kimberly-Clark	Andrex		2	92.0	119.6	0.769
GP	Walgreen	1000	1	81.2	127.6	0.636
Kimberly-Clark	Velvet		2	100.0	89.9	1.112
Kimberly-Clark	Scott	Deluxe	2	87.5	144.0	0.608
Delicarta	Aldi Solo	3-ply	3	87.3	104.5	0.835
Nampak	Twinsoft	2 Ply	2	102.2	125.8	0.813
Kimberly-Clark	Sujay		3	96.5	104.1	0.927
Kimberly-Clark	Wondersoft		2	95.1	101.2	0.939
Kimberly-Clark	Scott	Extra	2	87.3	96.1	0.909
SCA	Sorbent	Extra Thick	3	91.5	117.6	0.778
Kimberly-Clark	Scottenelle		2	104.4	124.9	0.836
Kimberly-Clark	Scott	Gold	2	98.8	162.2	0.609
Delitissue	Regina		2	105.3	103.7	1.016
P&G	Charmin	Basic	1	100.3	146.8	0.683
Nibong Tebal	Cutie	Compact	2	83.8	109.0	0.769
Tien Long Paper	Andante		2	104.2	125.0	0.833
Papeles Nacionales	Suave	Premium Gold	2	88.6	130.7	0.678
Potlatch	Albertson's		1	87.8	115.3	0.762
GP	Colhogar	mainline	2	90.4	104.0	0.868
Kimberly-Clark	Flamingo		2	78.4	106.8	0.735
Kimberly-Clark	Scott	1-ply	1	91.8	144.5	0.635
P&G	Charmin	Comfort	2	109.7	102.8	1.068

Manufacturer	Brand	Sub-Brand	Plies (number)	CDT/CD		CDTEA/CDS
				Stretch	TEA	
P&G	Charmin	Suave Aroma	2	103.3	118.1	0.874
Dellitissue	Regina		3	96.1	85.0	1.131
ICT	Foxy	Super Soft	2	98.8	106.1	0.931
CMPC	Elite	Diseno 2-ply	2	108.7	138.1	0.787
Kimberly-Clark	KleenexSujay		2	132.8	148.9	0.892
PT Pindo Deli	Paseo		3	103.2	104.8	0.985
Carrara	Migros Soft	3-ply	3	107.5	90.4	1.189
Kimberly-Clark	Andrex	POAR	2	106.9	115.4	0.926
Eroski	Linder	mainline	2	123.3	162.1	0.760
Kimberly-Clark	Scott	Select	2	118.3	132.5	0.893
GP	Tenderly	DermaSoft	2	92.8	104.0	0.892
GP	Northern	Ultra	2	87.9	122.9	0.715
Copamex	Flen		2	118.8	124.8	0.952
Kimberly-Clark	Dollar General		2	98.6	94.9	1.039
Sano	Kleenex	Care	2	113.3	133.7	0.847
Kimberly-Clark	SanoSoft		2	121.2	106.1	1.142
	Clean & Soft	International	3	117.8	97.7	1.205
	Andrex	mainline	2	94.9	112.0	0.847
Kimberly-Clark	Scott	Plus Mas	2	106.9	141.6	0.755
Kimberly-Clark	Scott	Metros	2	112.2	137.9	0.814
Kimberly-Clark	Neve	Natural	2	97.2	120.6	0.806
Kimberly-Clark	Sujay	Neutro	2	122.6	156.7	0.782
Kimberly-Clark	Scott	Extra	2	115.7	116.9	0.990
DaeHan Pulp	K-Nara		2	121.9	150.5	0.810
Kimberly-Clark	Tiss	-	2	154.0	160.4	0.960
	Coop Italia	mainline	2	143.3	157.1	0.912

Manufacturer	Brand	Sub-Brand	Plies (number)	CDT/CD Stretch	CDT/CD TEA	CDTEA/CDS
Kimberly-Clark	Kleenex	Care	2	134.4	168.7	0.796
Santher	Personal	1-ply	1	147.3	163.9	0.898
Santher	Personal	Premium	2	133.7	157.6	0.848
P&G	Charmin	Comfort	2	136.3	103.8	1.312
Kimberly-Clark	Moleft		2	128.2	136.2	0.941
Kimberly-Clark	Kleenex	Baby Soft	2	133.5	153.0	0.873
P&G	Charmin		2	122.4	131.0	0.934
Kimberly-Clark	Delsey		2	116.2	112.5	1.033
Kimberly-Clark	Kleenex	Boutique	2	127.8	165.2	0.774
ABC Tissue Products	Quilton		3	113.4	107.7	1.052
Kimberly-Clark	Neve	Elegance	2	133.3	163.1	0.817
Papeles Nacionales	Suave		2	120.6	149.1	0.809
Irving	Soft Weve		1	109.2	156.6	0.697
Kimberly-Clark	Andrex	Ultra (for HK)	3	147.3	156.9	0.939
Kimberly-Clark	Suavel		2	124.3	111.6	1.113
SCA	ASDA		2	164.3	124.2	1.323
Familia Sancela	Shades		2	138.6	170.4	0.813
Familia Sancela	Familia	Ultra Suave	2	149.9	170.6	0.879
Kimberly-Clark	Kleenex	Economico	3	141.0	146.1	0.965
CMPC	Elite	Ultra Care	2	173.2	145.6	1.190
Kimberly-Clark	Nice	Extra	1	148.5	254.5	0.584
Kimberly-Clark	Scott	1-ply	3	156.3	144.9	1.079
GP	Tesco	Deluxe	2	103.1	98.7	1.044
Mejhoramentos	Sublime	mainline	1	138.3	246.2	0.562
SCA	Carrefour	Classic	2	162.3	137.8	1.178
	Carrefour	mainline	2	155.3	153.1	1.014

Manufacturer	Brand	Sub-Brand	Plies (number)	CDT/CD Stretch	CDT/CD TEA	CDTEA/CDS
Kimberly-Clark	Servus	3-ply	3	164.0	122.3	1.341
Kimberly-Clark	Fancy		2	136.6	134.8	1.013
Kimberly-Clark	Scott	1000	1	112.8	134.5	0.839
Copamex	Lady Regio		2	143.1	131.0	1.092
P&G	Tender		2	166.3	171.5	0.970
Kimberly-Clark	Hakle Kamille	3-ply	3	166.1	115.6	1.436
	Coop Super		4	179.5	110.0	1.632
	Soft		3	149.8	104.3	1.437
	Clean & Soft	C & S	2	154.8	163.2	0.948
Kimberly-Clark	Lily		4	148.7	108.8	1.367
Delicarta	AS Schlecker	Premium	2	185.0	174.7	1.059
Kimberly-Clark	Petalo	Classico (Bahrain tissue)	2	102.9	114.6	0.898
Kimberly-Clark	Kleenex	Cuidado	2	177.3	226.2	0.784
Familia Sancela	Familia	Gold	2	172.3	187.3	0.919
Kimberly-Clark	Scott		4	164.9	99.6	1.655
	Denner		1	141.8	191.6	0.740
Marcal	Marcal		2	144.2	142.4	1.013
Yuen Foong Yu	Mayflower		2	186.5	188.8	0.988
Kimberly-Clark	Nice	Gold	2	188.6	136.2	1.385
APP group	Virjoy	2-ply	3	138.1	106.9	1.292
APP group	Virjoy	Premium	1	247.4	220.6	1.121
Productos Tissue del Peru	Noble	1-ply	1	195.5	237.1	0.825
Kimberly-Clark	Suave	Extra	3	210.9	162.2	1.301
Kimberly-Clark	Scott	Gold Ultra	2	170.2	161.5	1.054
CMPC	Elite	Doble Hoja	3	212.8	128.4	1.658
Kimberly-Clark	Hakle Kamille	3-ply				

Manufacturer	Brand	Sub-Brand	Plies (number)	CDT/CD Stretch	CDT/CD TEA	CDTEA/CDS
GP	Zewa Lind	3-ply	3	140.2	87.5	1.602
SCA	Edet	Friendly	3	160.5	93.4	1.718
Kimberly-Clark	Suave	Plus	2	198.0	180.9	1.095
Kimberly-Clark	Kleenex	500	2	145.7	126.1	1.156
Metsa	Lambi		3	216.1	134.5	1.607
CMPC	Elite	1-ply	1	218.9	216.8	1.010
Kimberly-Clark	Suave	Gold	2	201.5	211.8	0.952
GP	Lotus	Finesse	2	149.0	123.9	1.202
LIDL	Siempre		4	219.1	118.0	1.857
CMPC	Elite	Premium	3	189.2	149.5	1.266
	Vinda	regular	3	187.0	123.0	1.521
	Migros Soft	Extra	4	213.6	110.1	1.940
Soffass	Regina	Rotolini	2	198.8	141.5	1.405
APP group	Virjoy	Extra Soft	3	193.2	125.1	1.545
	Favorita	Plus	2	207.7	179.0	1.160
SCA	Velvet		2	192.7	157.8	1.221
Soffass	Regina	Cartacomomilla	4	237.6	138.1	1.720
CMPC	Elite	con Oso	2	190.8	159.0	1.200
	Vinda	premium	3	166.2	117.7	1.412
Vinda	Vinda blue		3	224.6	134.6	1.668
	Aldi Kokett		4	194.3	112.6	1.726
Kimberly-Clark	Vogue		2	217.2	173.8	1.249
Familia Sancela	Familia	Cuidado	2	344.4	310.9	1.108
San Francisco	Hortensia		2	403.3	196.1	2.056

As shown above, the samples made according to the present disclosure exhibited improved properties especially in the cross-machine direction in comparison to the commercially available samples. The samples made according to the present disclosure had the highest cross-machine directional stretch and the lowest amount of cross directional tensile needed to create 1% of stretch. The samples made according to the present disclosure also exhibited the lowest amount of cross directional tensile energy absorbed to create 1% of stretch. Further, the samples made according to the present disclosure exhibited the lowest cross-machine directional slope compared to the commercial products.

These and other modifications and variations to the present invention may be practiced by those of ordinary skill in the art, without departing from the spirit and scope of the present invention, which is more particularly set forth in the appended claims. In addition, it should be understood that aspects of the various embodiments may be interchanged both in whole or in part. Furthermore, those of ordinary skill in the art will appreciate that the foregoing description is by way of example only, and is not intended to limit the invention so further described in such appended claims.

What Is Claimed:

1. A single ply tissue product comprising:
a single ply tissue web comprising pulp fibers, the tissue web having a dry bulk of at least 3 cc/g, the tissue web having a geometric mean tensile strength of less than about 1,000 g/3 in, a cross-machine direction stretch of at least 11%, a cross-machine direction tensile strength/cross-machine direction stretch of less than about 50 and a cross-machine direction slope of less than about 3 kg.
2. A tissue product comprising:
at least one tissue web comprising pulp fibers, the tissue web having a dry bulk of at least 3 cc/g, the tissue web having a geometric mean tensile strength of less than about 1,000 g/3 in, a cross-machine direction stretch of at least 15%, a cross-machine direction tensile strength/cross-machine direction stretch of less than about 30 and a cross-machine direction slope of less than about 3 kg.
3. A tissue product as defined in claim 1 or 2, wherein the tissue web also has a cross-machine direction tensile energy absorbed/cross-machine direction stretch of less than about 0.4.
4. A tissue product as defined in claim 1, 2 or 3, wherein the tissue web has a cross-machine direction stretch of greater than about 14% and a cross-machine direction tensile strength/cross-machine direction stretch of less than about 30.
5. A tissue product as defined in claim 1, 2, 3 or 4, wherein the tissue web has a geometric mean tensile strength of less than 900 g/3 in, such as less than 700 g/3 in, such as less than 500 g/3 in.
6. A tissue product as defined in claim 1, 2, 3, 4 or 5, wherein the tissue web comprises an uncreped through-air dried web.
7. A tissue product as defined in claim 1, 2, 3, 4, 5 or 6, wherein the tissue web has a basis weight of from about 15 gsm to about 45 gsm.
8. A tissue product as defined in any of the preceding claims, wherein the tissue web has a Pinhole Coverage Index of about 0.25 or less, has a Pinhole Count Index of about 65 or less, and/or has a Pinhole Size Index of about 600 or less.

9. A tissue product as defined in any of the preceding claims, wherein the tissue web has been formed in a wetlaid through-air dried process by being conveyed on a transfer fabric positioned immediately upstream of a through-air dryer fabric that is configured to convey the web through a through-air dryer, both the transfer fabric and the through-air dryer fabric comprising textured fabrics having a machine direction dominate design comprising from about 5 to about 15 raised elements per centimeter in the machine direction, the raised elements having a height of from about 0.3 mm to about 5 mm.

10. A tissue product as defined in claim 9, wherein the raised elements have a height of from about 0.3 mm to about 1 mm.

11. A tissue product as defined in claim 9 or 10, wherein the transfer fabric and the through-air dryer fabric have a machine direction dominate design that comprises from about 9 to about 11 raised elements per centimeter in the machine direction, the raised elements having a height of from about 0.3 mm to about 0.5 mm.

12. A tissue product as defined in claim 9, 10 or 11, wherein the raised elements on the transfer fabric and on the through-air dryer fabric comprise ridges, the ridges having a width of from about 0.3 mm to about 1 mm, the ridges, when viewed from the cross-machine direction, having a ridge frequency of from about 0.5 mm to about 2 mm.

13. A tissue product as defined in claim 9, 10, 11 or 12, wherein the tissue web has been molded against at least one of the transfer fabric and the through-air dryer fabric during formation.

14. A method of producing a tissue web comprising the steps of:
forming a tissue web from an aqueous suspension of fibers, the aqueous suspension of fibers containing pulp fibers;
conveying the formed web on a transfer fabric positioned immediately upstream from a through-air dryer;
transferring the tissue web from the transfer fabric to a through-air dryer fabric that conveys the web through the through-air dryer, both the transfer fabric and the through-air dryer fabric comprising textured fabrics having a machine direction dominant design comprising from about 5 to about 15 raised

elements per centimeter in the machine direction, the raised elements having a height of from about 0.3 mm to about 5 mm; and

drying the web so that the web has a final moisture content of less than about 8%.

15. A process as defined in claim 14, wherein the raised elements have a height of from about 0.3 mm to about 1 mm.

16. A process as defined in claim 14 or 15, wherein the transfer fabric and the through-air dryer fabric have a machine direction dominate design that comprises from about 9 to about 11 raised elements per centimeter in the machine direction, the raised elements having a height of from about 0.3 mm to about 0.5 mm.

17. A process as defined in claim 14, 15 or 16, wherein the raised elements on the transfer fabric and on the through-air dryer fabric comprise ridges, the ridges having a width of from about 0.3 mm to about 1 mm, the ridges, when viewed from the cross-machine direction, having a ridge frequency of from about 0.5 mm to about 2 mm.

18. A process as defined in claim 14, 15, 16 or 17, wherein the transfer fabric and the through-air dryer fabric comprise multi-layered fabrics.

19. A process as defined in claim 14, 15, 16, 17 or 18, wherein the tissue web during the process is molded against at least one of the transfer fabric and the through-air fabric.

20. A process as defined in claim 14, 15, 16, 17, 18 or 19, wherein the tissue web is formed without applying a binder to the web.

1 / 2

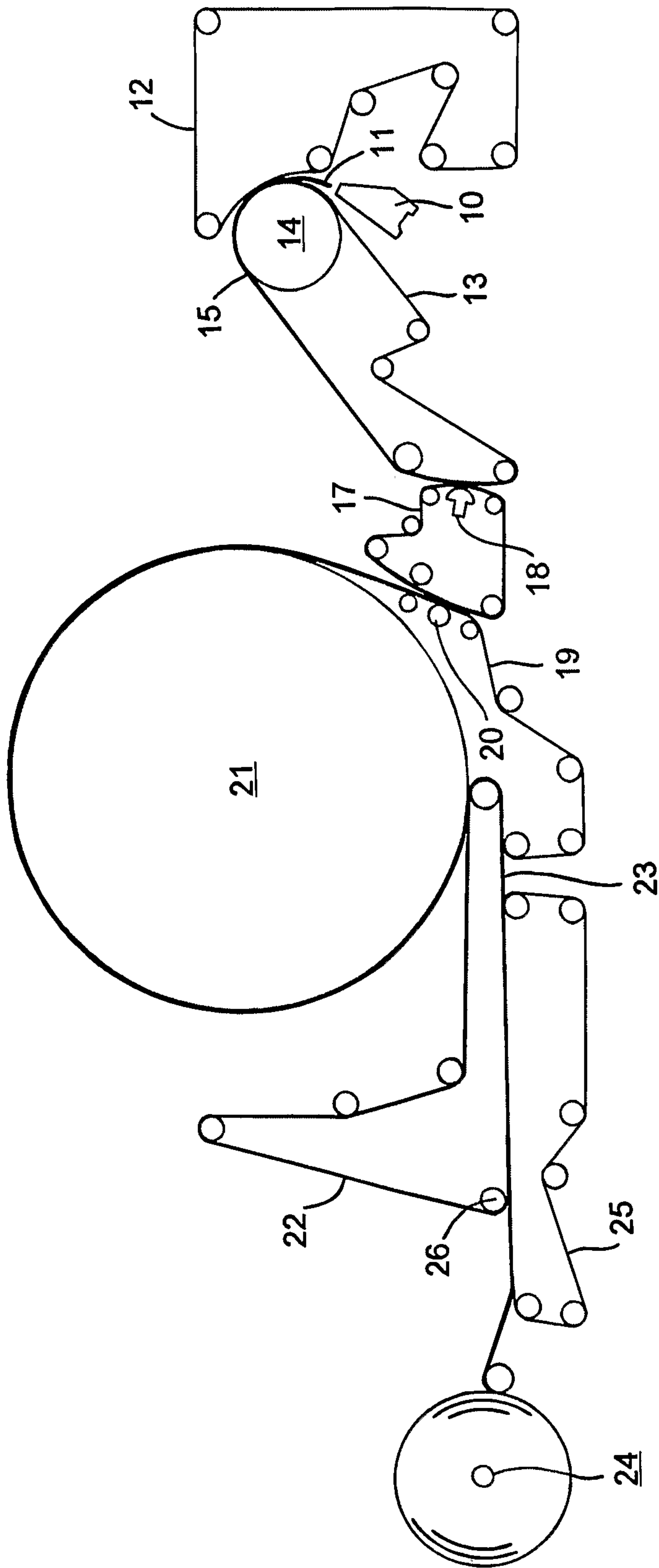

FIG. 1

2 / 2

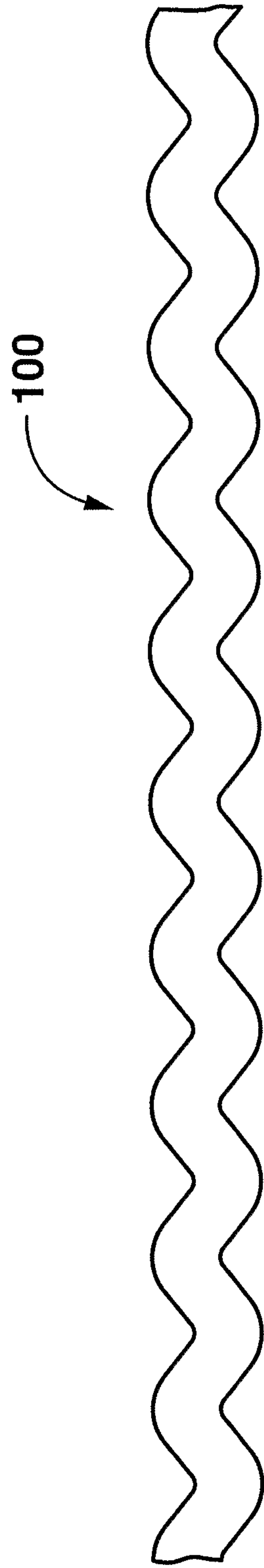

FIG. 2