

J. DELA MAR.  
CIGAR BUNCHING MACHINE.

No. 523,516.

Patented July 24, 1894.

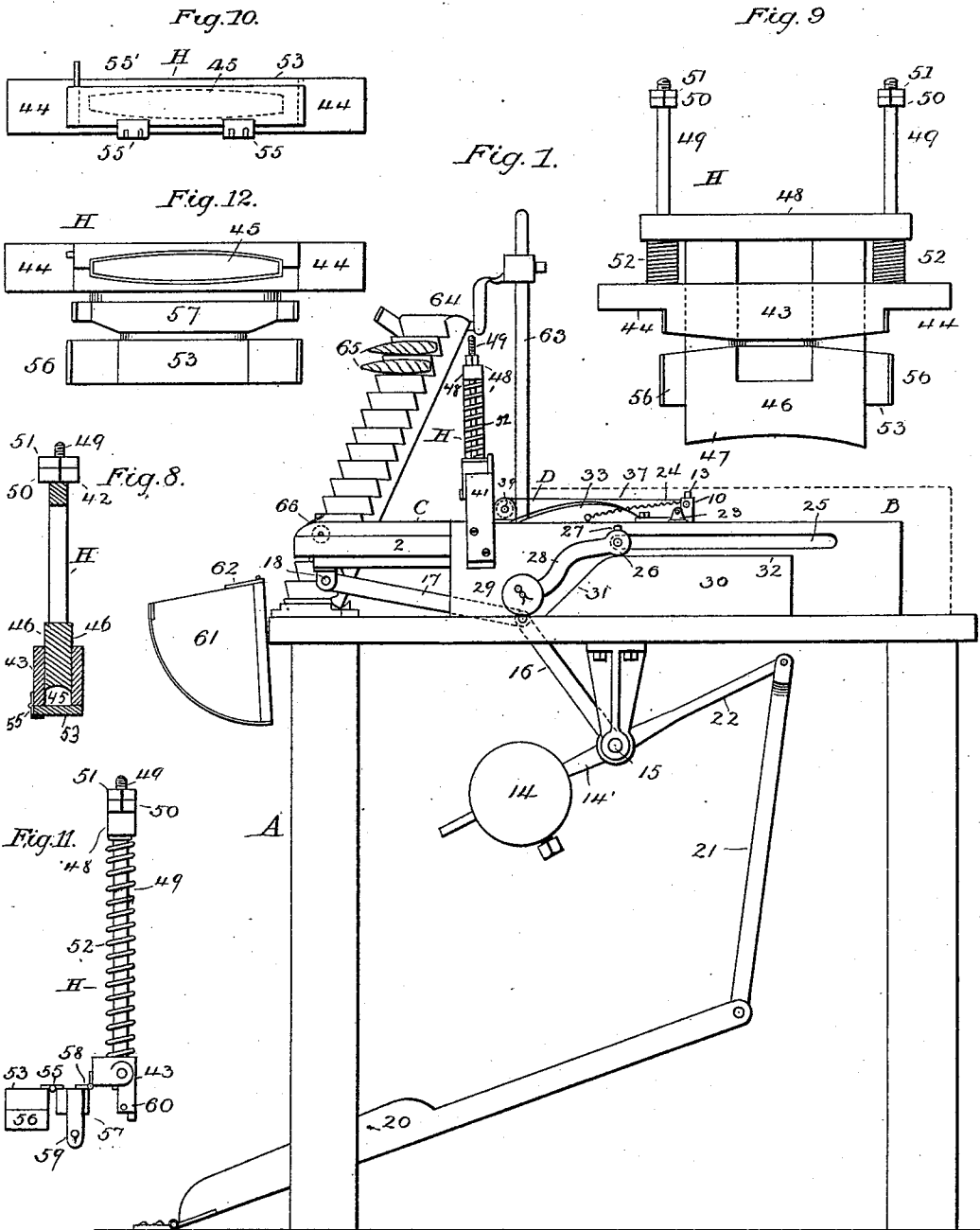

Witnesses:  
 Frank Simon  
 Joseph Montells.

Inventor:  
 Joseph Dela Mar  
 By Clarence Laidlaw-Davis  
 Atty.

(No Model.)

3 Sheets—Sheet 2.

J. DELA MAR.  
CIGAR BUNCHING MACHINE.

No. 523,516.

Patented July 24, 1894.

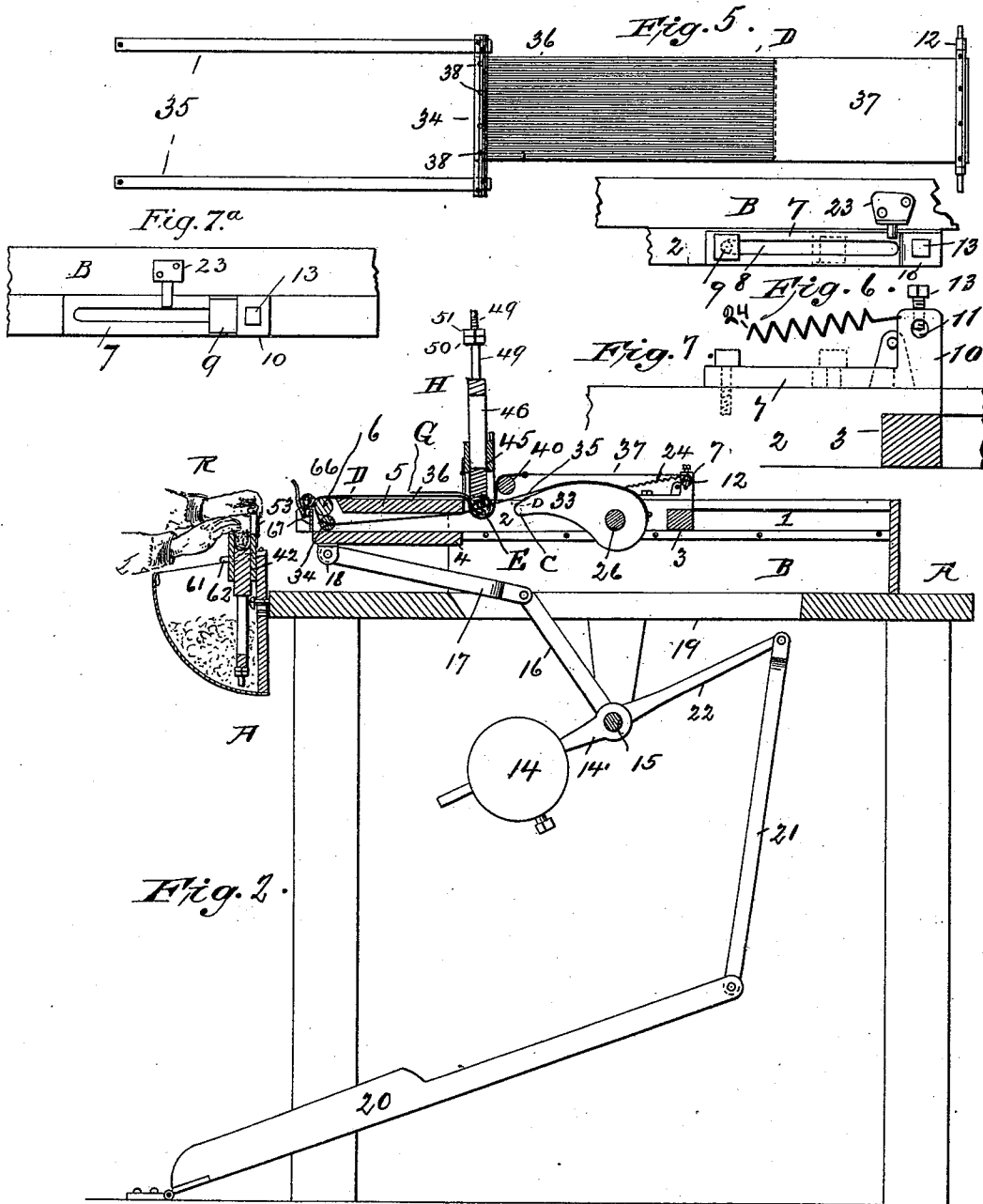

Attest:  
C. W. Benjamin  
Audrey Lyon

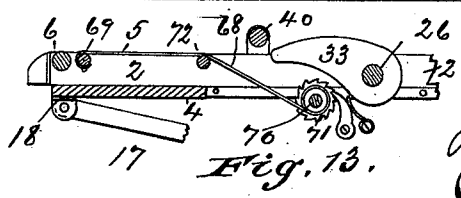

Inventor:  
Joseph Dela Mar  
by  
Clarence Ladd-Tani  
Atty.

J. DELA MAR.  
CIGAR BUNCHING MACHINE.

No. 523,516.

Patented July 24, 1894.

Fig. 3.

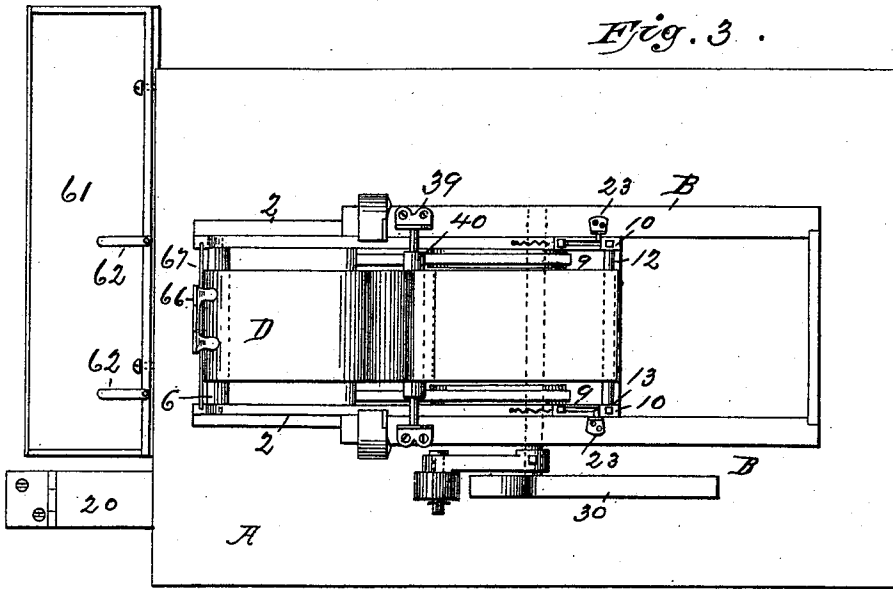
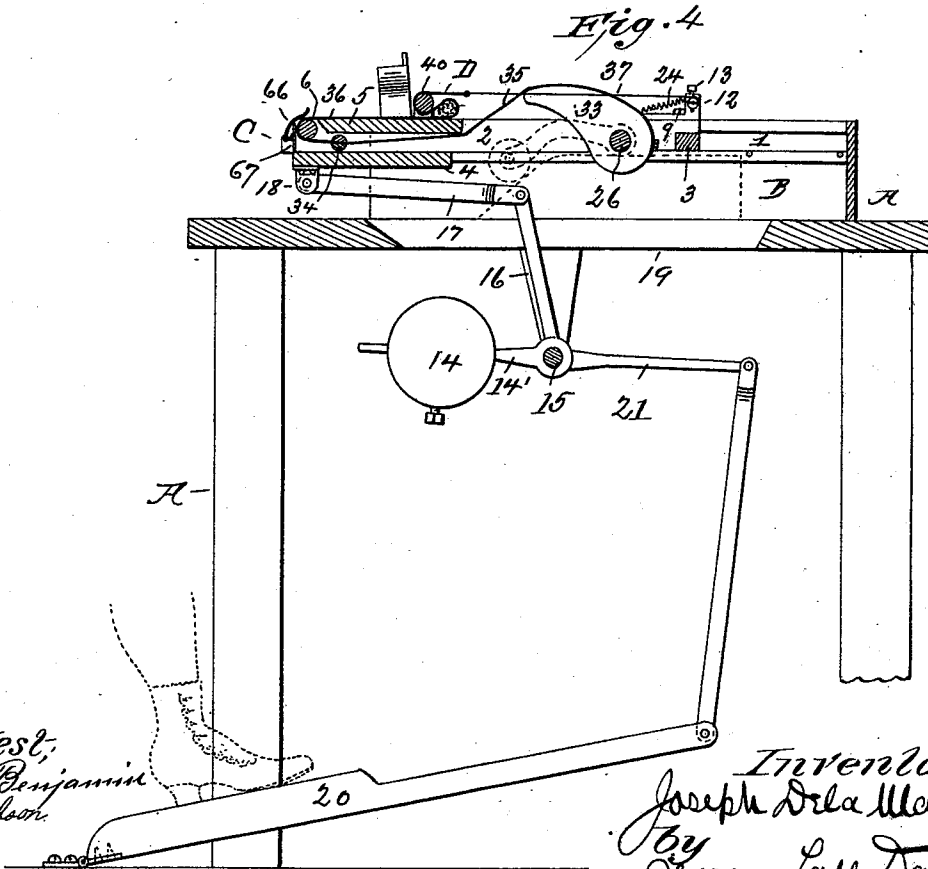

Fig. 4.



Attest:  
C. W. Benjamin  
Subj. Clerk

Inventor:  
Joseph Dela Mar  
by  
Charles Ladd-Daniels  
att'y

# UNITED STATES PATENT OFFICE.

JOSEPH DELA MAR, OF NEW YORK, N. Y., ASSIGNOR OF ONE-HALF TO  
LEON KLEIN, OF SAME PLACE.

## CIGAR-BUNCHING MACHINE.

SPECIFICATION forming part of Letters Patent No. 523,516, dated July 24, 1894.

Application filed January 9, 1894. Serial No. 496,304. (No model.)

### *To all whom it may concern:*

Be it known that I, JOSEPH DELA MAR, a citizen of the United States, residing in the city and county of New York, in the State of New York, have invented certain new and useful Improvements in Cigar-Bunching Machines, of which the following is a specification, such as will enable others skilled in the art to which it appertains to make and use the same.

The objects of my invention are: first, to provide a cigar-bunching machine of a new and improved form, of simple and cheap construction, which may be operated by unskilled labor; second, to so construct such machine that right or left taper, or straight bunches may be rolled thereon with ease, and without readjustment of any of the parts; third, to make a machine in which the bunches whether straight or taper, and although varying one from another in diameter, will all be of the same consistency throughout; fourth, to provide a machine of such form that when a suitable shaper is used therewith all the bunches formed thereon will be of like form as well as of like consistency throughout, whereby the necessity of compressing the bunches in forming molds after the same are made is obviated, and a bunch is formed that when wrapped and finished into a cigar cannot be told from the highest grade of hand-work; and fifth, to provide a removable shaper for use with cigar-bunching machines of any form, which shaper is so constructed as to be easily and quickly filled and as quickly emptied, which shaper when used will deposit upon the bunch-rolling-apron of the machine the required quantity of filler tobacco in such shape and form as to cause the machine to form and roll such filler tobacco into a bunch of the required shape, size and consistency; and to such ends, my invention consists of the construction, combination, and arrangement of the several parts of my improved cigar-bunching machine, together with the bunch-rolling-apron and the removable shaper, which while not limited strictly to use therewith, are more particularly designed and adapted to be used with my improved form of cigar-bunching-machine; all of which are more fully shown and described in the following specification of which the accompanying

drawings form a part, wherein similar letters and numerals of reference designate like or equivalent parts wherever found throughout the several views, and in which—

Figure 1, is a side view in elevation of my improved cigar-bunching machine; Fig. 2, a like view in central vertical section thereof, showing the position assumed by the various parts, as the filler tobacco out of which the bunch is to be formed is deposited upon the binder-leaf placed for that purpose in the rolling-bight of the bunch-rolling-apron. Fig. 3, is a top plan view of Figs. 1, and 2, with the shaper and finished bunch-holder removed; and Fig. 4, is a view of the machine in central vertical section, similar to Fig. 2, except that the moving parts are shown in the position assumed by them during the operation of rolling the bunch. Fig. 5, is a detail view of the bunch-rolling-apron D, and attachments. Figs. 6 and 7, are detail top and side-views respectively of the sliding connection by which the bunch-rolling-apron D is secured to the carriage at the rear end thereof, and Fig. 7<sup>a</sup> is a top view thereof similar to Fig. 6 showing the relative position assumed by the various parts when at or near the extreme point of rearward movement of the carriage. Fig. 8 is a detail side view in central vertical section, and Fig. 9, a front view in elevation, of my improved form of shaper, and Fig. 10 a bottom view of such shaper. Figs. 11 and 12 are bottom and side views respectively of a shaper of a somewhat modified form of construction from that shown in Figs. 8, 9 and 10; and Fig. 13, is a detail view, in central vertical longitudinal section, of a modified form of rolling-bed and the carriage on which the same is mounted.

In said drawings the reference letter A designates a supporting stand or table formed preferably of wood and metal, as are nearly all the various parts of the machine, and B designates two side pieces supported on the table A which pieces extend longitudinally of such table and serve as a support for the reciprocating carriage C, upon which carriage is mounted the bunch-rolling apron D, while H designates my improved form of shaper.

Referring to the drawings: The reference numeral 1, designates suitable ways formed

in the two side-pieces B, which ways 1 form a suitable track back and forth in which reciprocates freely the carriage C, which carriage C is preferably of substantially the shape shown, consisting of longitudinal side-pieces 2 secured together at the rear ends by a cross-bar 3, which bar 3 is preferably only about half the thickness of such side-pieces 2, and at the front or forward end by a bottom-piece 4 and an upper-piece or rolling-bed 5, each of which pieces 4 and 5 extends from the front end of the carriage to the distance of about one-third the length thereof, as shown in Fig. 4.

Extending across the front end of the carriage C and revolubly mounted in the side-pieces 2 thereof so as to practically form an extension of the rolling-bed 5 is a roller 6, and mounted upon the side-pieces 2 of such carriage at the rear ends thereof are upwardly extending brackets 7 of substantially the shape shown in Figs. 6, 7 and 7<sup>a</sup>, which brackets are provided in the lower portions with slots 8 through which pass bolts 9, by which bolts such brackets are secured to the side-pieces 2 of the carriage in such manner as to slide easily back and forth thereon the length of the slots 8. Formed in the upward extensions 10 of such brackets are bearings 11 which are adapted to receive the ends of the bar 12 to which is secured the rear end of the bunch-rolling-apron D, which bar 12 is prevented from turning in the bearings 11 by suitable set-screws 13 of ordinary form which screw into suitable holes formed for that purpose in such brackets.

The reciprocating carriage C is kept normally forced toward the front end of the table A by any convenient means, preferably by a counter-poise-weight 14 mounted upon a lever 14', which lever is rigidly secured to a shaft 15 which is in turn rigidly secured to a lever 16 which is in pivotal connection with a connecting-rod 17 which rod is connected with the reciprocating carriage C in any desired manner preferably by a pivotal connection 18, such weight 14 and shaft 15 being preferably located beneath the table A as shown, and the lever 16 passing up through a slot 19 formed in the top of such table for such purpose. The said carriage is forced rearward when desired by a treadle 20, connected with the shaft 15 by a connecting-rod 21 and lever 22, all as shown in Figs. 1, 2 and 4; and said carriage C is limited in its forward movement and is prevented from being forced beyond a certain point by the weight 14, when returned by such weight to its normal position, by stops 23 which are secured to the side-pieces B and abut against the front sides of the upward extensions 10 of the brackets 7 so as to stop the same while the carriage C continues its forward movement until stopped by the bolts 9 reaching the forward ends of the slots 8 in the lower portions of such brackets 7, as shown in full lines in Figs. 6 and 7, which brackets 7, when

not in contact with the stops 23 are kept normally forced toward the front of the reciprocating carriage C by springs 24, which springs are secured at one end to the brackets 7 and at the other to the side-pieces 2 of the said carriage C, such front position being shown in Figs. 4, and 7<sup>a</sup>, and in dotted lines, showing the position assumed by the bolts 9 during rearward movement of the carriage, in Figs. 6 and 7. It will be seen that by this form of construction the rear end of the bunch-rolling-apron D is secured to the rear end of the carriage C by a yielding connection which remains stationary during the first portion of the rearward working movement of the carriage, whereby the position of the rear end of the apron, which is connected with such yielding connection, relative to the bunching-roller, is not changed, until such time as the bight is closed, when the yielding connection is carried rearward with the carriage, and thereby draws the apron over such bunching-roller to roll the bunch as shown, and while I prefer to use the form of connection shown, I do not limit myself strictly thereto, as any connection which will bring about substantially the same action upon the said apron in substantially the same manner, may if desired be used.

Revolubly mounted in suitable bearings formed for that purpose in the side-pieces 2 of the carriage C with one end thereof extending through a slot 25 formed for that purpose in one of the side-pieces B of the table A, is a shaft 26 to the extended end of which outside of the slotted side-piece B, is rigidly secured, preferably by means of a set-screw 27 so as to be adjustable thereon, a cam-lever 28, preferably of substantially the shape shown, which to facilitate ease of operation is preferably provided near the outer end with a revoluble wheel or roller 29.

Secured to the table A in any desired manner outside of the side-piece B is a cam-piece 30 of substantially the shape shown, having an inclined front edge 31 and a substantially straight upper edge 32, and such cam-piece 30 is located upon the same side of the machine as is the cam-lever 28 in such manner that when the reciprocating carriage C is moved to the rear of the table A the roller or wheel 29 on such cam-lever 28 will be forced up the inclined front edge 31 and along the straight top edge 32 of the cam-piece 30 (as shown in dotted lines in Fig. 4) so as to partially rotate the shaft 26 to the end of which is secured such cam-lever 28.

Rigidly secured to the shaft 26, preferably immediately adjacent to the side-pieces 2 of the carriage C are eccentric cams 33, preferably of substantially the shape shown, the longer actuating ends of which extend toward the front of such carriage, and the front end of the bunch-rolling-apron D is in connection in any desired manner with these cams 33 so that such apron will be drawn to the rearward of the carriage C underneath the rolling-bed 5,

preferably by being securely fastened in any desired manner to a bar 34 adapted to move freely back and forth between the rolling-table 5 and the bottom 4 of such carriage C, as shown in Figs. 2 and 4, from each end of which bar there extend back over said cams to the rear side thereof where the same are securely fastened thereto, two straps 35, preferably of leather or other suitable material.

The bunch-rolling-apron D, as shown in detail in Fig. 5, is preferably composed of a front or working portion 36 of some material which in addition to being flexible is also highly elastic, and of a rear portion which is flexible but not elastic, and such form of apron I have found preferable to others for many reasons, but in some cases the entire apron may be formed of such highly elastic material, and in others of material which is flexible but not elastic. When such bunch-rolling-apron, or any portion thereof, is made of highly elastic material, I have found it preferable to use for such purpose the cloth or fabric woven partly of threads of elastic india-rubber and partly of linen or other suitable non-elastic threads, such as is commonly used to form the elastic side-pieces of the uppers of Congress shoes or gaiters.

The bar 34 which plays freely back and forth underneath the rolling-bed 5, and to which are securely fastened the forward end of the apron D and the forward ends of the two cam-straps 35, to facilitate the fastening thereto of such apron and straps is split longitudinally into two pieces between which the ends of such apron and of the straps 35 are inserted and there securely clamped in position by means of suitable screws 38 by which the two parts of such bar 34 are held firmly together; and the rear end of such apron D is secured to the bar 12 in a similar manner, such bar 12 being also split longitudinally thereof in the same manner as is the bar 34, and like it being also secured together by means of suitable screws.

Rigidly mounted upon the two side-pieces B of the table A near the forward ends thereof, are suitable bearings 39, in which are revolubly mounted a bunching-roller 40 the position of such bearings and the size of the roller being such that when the reciprocating carriage C is in its normal position there will be a space of say an inch or so between such bunching-roller 40 and the rear end of the rolling-table 5, as shown in Fig. 2, the bottom of such bunching-roller being a short distance, say a quarter of an inch above the top of the rolling-bed 5 so as to allow the carriage C to reciprocate freely back and forth beneath the same; and located immediately forward of such bunching-roller 40, and firmly secured to the side-pieces B are two bracket-pieces 41 preferably of substantially the shape shown, which are adapted to receive and hold in position by gravity therein a removable shaper H, holding in a suitable mold cavity formed therein the required

quantity of tobacco filler, of the required shape and size, from which shaper such tobacco-filler may be ejected into the rolling-bight E of the bunch-rolling-apron D, which bight E is normally located between the rear end of the rolling-table 5 and the forward side of the bunching-roller 40, as shown in Fig. 2.

The shaper H is ordinarily and preferably of the simple form of construction shown in Figs. 8, 9, and 10, consisting of a block 43 of wood or other suitable material, preferably of substantially the shape shown, having the extending end portions 44 to extend over and support the same on the bracket-pieces 41, and also to support such shaper in an inverted position for filling, as hereinafter described, and in such block 43 is formed a mold-cavity 45 of the shape of the bunch desired to be formed upon the machine, which mold cavity 45 extends entirely through such block 43 from top to bottom thereof, and in such cavity slides freely back and forth an ejecting-plunger 46, preferably the same shape in cross-section as is such mold-cavity, the bottom end of such plunger 46, which when in position forms one of the walls of the same, being shaped and hollowed out into a substantially cigar shape as shown at 47 in Fig. 9, and the top thereof being provided with a cross-bar 48 rigidly secured thereto, which cross-bar is provided at the ends thereof with suitable holes through which pass rods 49 the lower ends of which are rigidly secured to the block 43, and the upper ends of which are screw-threaded and provided with suitable adjusting and jam-nuts 50 and 51, the holes in the ends of the cross-bar 48 being of course made slightly larger in diameter than are the rods 49 so as to allow such cross-bar to slide freely up and down the same, so as to allow the plunger 46 to be reciprocated through the mold-cavity 45, as shown in Fig. 9, such plunger being normally retracted back into such cavity, so as to allow the same to be filled from the bottom, by suitable springs 52 interposed between the cross-bar 48 and the block 43 and coiled around the rods 49.

The bottom or open end of the mold-cavity 45 of the block 43 is normally closed by a bottom-piece 53, of such shape upon the inner-side thereof as to conform to the curved lower side 54 of the mold-block, which bottom-piece 53 is secured to the said block by hinges 55, and is provided with spring flanges 56 at the ends thereof, which are adapted to tightly clasp the ends proper of the block 43 when such bottom-piece is closed down so as to hold the same tightly in place, or such bottom-piece may be kept normally closed in any other desired manner, and I prefer to make said bottom-piece 53 as well as said flanges 56 of sheet brass bent to conform to the curved lower side of said block 43, and in all cases to facilitate the opening of the same, such bottom-piece is preferably provided with a suitable thumb-piece 53'.

The form of shaper just described is that ordinarily used by me with my improved form of machine, and while the same may be used for long filler as well as short filler tobacco, for forming bunches of the highest grade of long-filler tobacco, I prefer to use a shaper of a somewhat modified form of construction, such as I have shown in Figs. 11, and 12, which differs from the form shown in Figs. 8, 9, and 10, only in the fact that the block 43 is split or sawed longitudinally thereof from the center of the bottom and one side toward the center until such splits or saw-kerfs meet, so that a piece 57, which when in place forms one side of the lower part of the mold-cavity 45, may be removed, and such piece 57 is then hinged to the remainder of the block 43 from which it has been sawed by means of suitable hinges 58, and is also provided with a suitable spring catch 59 adapted to engage with a pin or other suitable device 60 on the block 43 when such piece is swung into its closed position, so as to be held so closed, and to such movable-piece 57 is in turn hinged the bottom-piece 53, which bottom-piece 53, as well as all the other parts of this modified form of shaper, not enumerated in this paragraph, is of substantially similar construction as in the form of shaper shown in Figs. 8, 9, and 10 and herebefore described.

Removably secured to the forward end of the table A is a tobacco-receptacle or box 61, preferably of substantially the shape shown, out over the open top of which project two supports 62 placed such a distance apart as to allow the removable shaper H to be supported thereon in an inverted position, by reason of the extended end portions 44 of the block 43 of such shaper extending across the same, as shown at R in Fig. 2, and resting on such table, also at the forward end thereof, and preferably supported in an inclined raised position to the left of the forward end of the reciprocating carriage C, by means of a suitable adjustable support 63 is a finished bunch-holder 64 having suitable grooves 65 formed therein for holding the finished bunches after the same are taken by the operator from the spring-bunch-catcher 66 located at the extreme forward end of the rolling-bed 5, in which the same are automatically deposited by the bunch-rolling-apron D.

The spring-bunch-catcher 66 may be of any desired form, preferably of that shown, and is secured to the forward end of the reciprocating carriage C in any desired manner, preferably by being secured to an end bar 67 removably secured in grooves formed for that purpose in the ends of the side-pieces 2 of the carriage C, as shown in Fig. 3, by which arrangement easy access may be obtained to the space between the rolling-bed 5 and the bottom-piece 4 of such carriage, when desired.

For forming the greater number of the various shapes and sizes of bunches I prefer to

use the rigid form of rolling-bed shown in Figs. 2, 3, and 4, but for some certain shapes I prefer to use a rolling-bed formed of some flexible material such as canvas or leather, which in some cases may if desired be made of highly elastic as well as flexible material, and when such flexible rolling-bed is used I prefer to use the particular form shown in detail in Fig. 13, in which the rolling-bed 5 is formed of a sheet of suitable flexible, or flexible and elastic material 68, the forward end of which sheet is firmly secured to a bar 69, the ends of which are secured in the side-pieces 2 of the reciprocating carriage C, immediately forward of the roller 6, and the forward end of such sheet is firmly secured to a roller 70 revolvably mounted in such side-pieces 2 of said carriage C below the cams 33, which roller 70 is provided with a ratchet and pawl mechanism 71, and suitable means, (not shown) for rotating the ratchet, whereby such sheet 68 may be kept at all times taut, the rolling-bed portion 5 thereof, being of course made substantially level by passing over a suitable bar 72, similar in form to the bar 69 and like it mounted in the side-pieces 2 of such carriage C, in such manner as to form the rear end of such rolling-bed, as shown in said Fig. 13, or if desired, such sheet may be tightened in any other desired manner.

The operation of said machine is as follows:—The machine being at rest, and the various parts thereof being in the positions shown in Fig. 2, the person about to operate the same places himself in front of the table A in a sitting or standing position, as desired, with one foot upon the treadle 20, and taking one of the removable shapers H places the same in an inverted position upon the brackets 62, as shown at R in Fig. 2, and after turning back the hinged bottom-piece 53 thereof proceeds to fill the mold-cavity 45 of such shaper H with tobacco-filler taken from the box or receptacle 61, the size of such cavity, as well as that of the rolling-bight E of the bunch-rolling-apron D having been beforehand made of the right size by a proper manipulation and adjustment, in the case of the shaper of the nuts 50 and 51, and in the case of the apron of the bar 12. If the modified form of shaper shown in Figs. 11 and 12 is the one which is used after the same is inverted upon the brackets 61 the hinged movable-piece 57 as well as the hinged bottom-piece 53 thereof, is thrown back into the open position, as shown in Figs. 11, and 12, so that access may be had to the mold cavity 45 from the side and the required quantity of filler tobacco be placed therein and built up from the bottom in a proper manner to form a well formed bunch when submitted to the action of the machine. In either case as soon as the mold cavity of such shaper H has been properly filled, the bottom-piece is closed down over the open side thereof, and such shaper is then placed in an upright position, with the bottom-piece 53 thereof downward, in the

bracket-pieces 41, as shown in Fig. 1, and a binder-leaf G of suitable tobacco-leaf having been spread out on the bunch-rolling-apron D so that the portion of the same toward the rear of the table A extends over and covers the rolling-bight E of such apron D, the tobacco-filler contained in the mold-cavity of the shaper H mounted on the brackets 41 is deposited on the binder-leaf G and in such rolling-bight E, by forcing down the cross-bar 48 of such shaper H, so as to force the plunger 46 thereof down through the mold-cavity, as shown in Figs. 2, and 9, and as soon as the cross-bar 48 of such shaper is released from pressure the plunger 46 will be drawn back into the mold-cavity by the springs 52, but the tobacco-filler will be left in the rolling-bight E of the bunch-rolling-apron D. The operator then presses down upon the treadle 20 with his foot, and the reciprocating carriage C is forced backward toward the rear of the table A, but inasmuch as the bar 12 to which is secured the rear end of the apron D is kept from moving rearward with the carriage by the action of the springs 24, until the bolts 9 on the carriage strike against the rear ends of the slots 8 of the brackets 7, and as not until or about such time as said brackets 7 have reached their fullest forward position on the carriage C, does the roller 29 on the cam-lever 28, strike against the lower portion of the inclined end 31 of the cam-piece 30 and begin to ascend the same, is the bunch-rolling-apron D tightened; and inasmuch as such apron D, during the first two inches or so of the rearward working movement of the reciprocating carriage C, is not moved or drawn over the bunching-roller at all, the rear end of such apron and such bunching-roller retain the same relative position until the bight is closed by the rear end of the rolling-bed passing beneath such roller, at which point of the rearward working movement of the carriage the rear of the apron for the first time begins to move rearward with the rolling-bed, when consequently the apron is drawn over the bunching-roller, and the filler in the bight begins to be rolled over and over therein as the carriage continues to move rearward in such manner as to form the bunch in the well known manner, and by reason of the fact that the apron is not drawn rearward over the bunching-roller until the bight is closed, it is possible to use a much smaller bight than would otherwise be necessary in order to prevent the filler being thrown out of the bight upon the first rearward movement of the machine, and when an elastic belt is used this is of great advantage, as otherwise and when a very large bight is used, the first movement of the cams which operate to tighten and stretch the belt, if a perfect bunch is to be formed, is so great and so abrupt in order to take up the slack of the bight, that the binder is liable to be drawn out of the same, or a loosely formed and bunch of poor quality be made. By the arrangement

shown, as soon as the bight is closed, and before the belt has been tightened by pulling on the same it will be found that the apron is tightly closed around the filler so as to keep the same in the required shape from the very first movement at which the rolling action begins. As the rearward working movement of the carriage and rolling-bed continues after the closing of the bight, the roller 29 is forced up the inclined end 31 of the cam-piece 30 by the rearward movement of said carriage C, the cams 33 are partially rotated so that the long forwardly projecting ends thereof are forced up into the position shown in Fig. 4, and the bunch-rolling-apron D is of course tightened thereby, and as said cams 33 are raised higher and higher as the roller 29 continues to rise higher and higher up the inclined end 31 of the cam-piece 30, greater and greater force is of course brought upon the straps 35 the rear ends of which are secured to such cams 33, and the front ends of which are secured to the bar 34 to which is also secured the forward end of the bunch-rolling apron D, and as this continues as the carriage C continues to move rearward upon the table A until the top of the cam-piece 30 is reached and the roller 29 is moved along the same, the binder-leaf G is of course rolled tightly around the filler-tobacco ejected from the shaper H into the rolling-bight E, by the action of the bunch-rolling-apron D, in the well known manner, except that the tightening of such apron D, coupled with the natural elasticity thereof, causes such apron to accommodate itself to the varying diameter of the different portions of the bunch, and to roll it substantially equally tight in the binding-leaf G at all points along the length thereof, irrespective of the varying diameter of the same; and the bunch so formed is rolled over and over in the rolling-bight E of such apron D as the carriage C continues to move rearward until at last, as the roller 6 forming the forward end of the rolling-table 5 passes beneath the bunching-roller 40, such bunch is ejected from the rolling-bight E, and is caught by and held in the spring-bunch-catcher 66, as shown in Fig. 2, when the foot of the operator being removed from the treadle 20, the reciprocating carriage C will of course be at once returned to its normal position at the front of the table A by the action of the weight 14, when the parts will be in the position shown in Fig. 1, and the operation just described may be again repeated.

The period of the backward movement of the reciprocating carriage C at which the cams 33 begin to pull upon the straps 35 so as to tighten the bunch-rolling-apron D, may be regulated in any desired manner, preferably by changing the position of the cam-lever 28 on the shaft 26 by means of the set-screw provided for that purpose; and the size of the rolling-bight E of such an apron D may in like manner be regulated and increased or diminished in size as desired by rolling more or less

of the same upon the bar 12 to which the rear end of such apron is secured, and then securing such bar against reverse rotation in the bearings 11 in the extensions 10 of the brackets 7, by means of the set-screws 13, or the straps 35 or even the belt itself may be shortened in any desired manner with the same effect.

In practice it may sometimes be found desirable to have more than one person at work at the same machine at the same time, and when this is so, the rear portion of the side-pieces B, and the table A, are covered by a flat-topped box (shown in dotted lines in Fig. 1), beneath which the carriage C may reciprocate freely back and forth, and a tobacco receptacle similar to the box 61 is hung upon the rear end of the table A in the same manner as is the box 61 to the front end thereof, and while one or more persons are engaged in filling the removable shapers H (a number of which are in such case provided for that purpose) with the required quantities of tobacco-filler, and placing the same when filled upon the top of the inclosing cover where they can be reached by the operator standing or sitting at the forward end of the table, who is engaged wholly in emptying such shapers, so filled by the others, into the rolling-bight E of the bunch-rolling-apron D, supplying binder-leaves G to wrap such filler-tobacco in, from the box 61, rolling the bunches, taking the same from the spring-bunch-catcher and depositing same in the finished-bunch-holder 64, and in returning the empty shapers to the top of the inclosing cover, to be refilled by those engaged in performing that service.

It will be seen that in both forms of my improved removable shapers shown and described herein the lower or ejecting end of the plunger, when the shaper is inverted for the purpose of filling the same, forms what is at such time the bottom of the mold-cavity 45, and that the size of such cavity may be materially increased or diminished by the proper manipulation of the screw-threaded stop and jam-nuts 50 and 51 on the rods 49, by which the normal position of the cross-bar 48 on said rods 49, and consequently also that of the lower end of the plunger 46 in the mold-cavity 45, will be regulated as desired. And by the use of a shaper of this form, I am enabled, simply by a proper adjustment of the size of the mold-cavity, and of the rolling-bight E of the bunch-rolling-apron D of the machine with which the same is used, to form bunches of many different shapes and sizes at a minimum of expense by reason of using only one shaper for all of them, instead of one for each shape. Furthermore, by the use of such shaper in connection with my improved form of bunching-machine herein shown and described, as the bunches then formed are regular of shape, perfect of form, without hardness, and of the same general consistency throughout, and bear every ap-

pearance of having been made by hand, I am able to form with low priced, unskilled labor, a bunch that when properly wrapped and finished into a cigar cannot be told from one which has been wrapped wholly by the highest grade of skilled labor; yet while I prefer to use such shaper with my improved form of bunching-machine, in some cases the use thereof may be omitted, and the required quantity of filler tobacco be placed in the rolling-bight E of the bunch-rolling-apron D by hand, or in any other desired manner.

Although I have shown and described the bunching-roller 40 as being revolubly mounted in suitable bearings, and while I prefer to so mount such roller by reason of there being less friction, in some cases and for certain kinds and forms of bunches, it may be found preferable to have such bunching-roller 40 made of other than a cylindrical form, and to have the same secured rigidly instead of revolubly in place, and I do not in any case intend to limit myself to either a cylindrical or revolubly mounted bunching-roller; in like manner, and while I have shown the bunch-rolling-apron D as having only the working-portion thereof formed of a highly elastic material, it may sometimes be preferable to form such belt throughout its entire length of such highly elastic material, or in some cases it may be made wholly of flexible but non-elastic material, but I prefer to use a bunch-rolling-apron of the form of construction shown, as I have obtained the best results from such form of apron. However, I do not intend to limit myself strictly to the exact form of construction of the whole or any of the parts of my improved form of cigar-bunching-machine, or of the removable shaper, shown and described herein, as it is evident that many changes in the construction, combination and arrangement of the various parts thereof, other than those mentioned herein, may be made without departing from the scope of my invention, and I do not intend to limit myself to any particular form thereof, but,

Having now particularly described and ascertained the nature of my said invention, its construction and operation, what I claim, and desire to secure by Letters Patent, is—

1. In a cigar bunching machine, the combination, with a reciprocating carriage of a rolling-bed mounted on the carriage, a bunching-roller, a bunch-rolling-apron mounted wholly upon and carried by the carriage and supported wholly thereby so as to move bodily therewith, and means for tightening the apron as the carriage performs its rearward working movement during bunching, substantially as shown and described.

2. In a cigar bunching machine, the combination with a reciprocating carriage, of a rolling-bed mounted thereon, a bunching-roller, a bunch-rolling apron mounted upon and carried wholly by the carriage and supported wholly thereby so as to move bodily there-

with, means for preventing change in the relative positions of the rear end of the apron and of the bunching-roller during the closing of the bight upon the first working movement of the carriage rearward, and means for drawing upon the forward end of the apron in advance of the bight so as to tighten the apron as the carriage continues to move rearward after the closing of the bight, substantially as shown and described.

3. In a cigar bunching machine, the combination with a bunch-rolling-apron the working portion of which is elastic throughout its entire width, of a rolling-bed, a bunching-roller, means for closing the bight of the apron by changing the relative positions of the bunching-roller and rolling-bed, means for preventing change in the relative positions of the rear end of the apron and of the bunching-roller during the closing of the bight, and means for drawing upon the apron in advance of the bight after the same is closed so as to tighten and stretch the same, substantially as shown and described.

4. In a cigar bunching machine, the combination with a bunch-rolling-apron the working portion of which is elastic throughout its entire width, of a rolling-bed, a bunching-roller of the form of a right cylinder, means for closing the bight of the apron by changing the relative positions of the bunching-roller and rolling-bed, means for preventing change in the relative positions of the rear end of the apron and of the bunching-roller during the closing of the bight, and means for drawing upon the apron in advance of the bight after the same is closed so as to tighten and stretch the same, substantially as shown and described.

5. In a cigar bunching machine, the combination with a reciprocating carriage, of a rolling-bed, a bunching-roller, a bunch-rolling-apron the working portion of which is elastic throughout its entire width, positive means for preventing the throwing of the bunch filling from the bight during the movement of the carriage while closing the same, and means for drawing upon the forward end of the apron in advance of the bight so as to tighten the apron as the carriage continues to move rearward after the closing of the bight, substantially as shown and described.

6. In a cigar bunching machine, the combination with a reciprocating carriage, of a rolling-bed, a bunching-roller, a bunch-rolling apron mounted upon the carriage and carried wholly thereby and supported wholly thereon so as to move bodily therewith, means for preventing the throwing of the bunch filling from the bight during the first rearward working movement of the carriage, and means for drawing upon the forward end of the apron in advance of the bight as the carriage continues its rearward working movement after the closing of the bight, substantially as shown and described.

7. In a cigar bunching machine, the combi-

nation with a reciprocating carriage, of a rolling-bed, a bunching-roller, a bunch-rolling apron mounted upon the carriage and carried wholly thereby and supported wholly thereon so as to move bodily therewith, means for preventing change in the relative positions of the rear end of the apron and of the bunching-roller during the first movement of the mechanism in closing the bight, and means for drawing upon the forward end of the apron in advance of the bight so as to tighten the same during the rearward working movement of the carriage after the closing of the bight, substantially as shown and described.

8. In a cigar bunching machine, the combination with a reciprocating carriage, of a rolling-bed, a bunching-roller, a bunch-rolling apron mounted upon the carriage and carried wholly thereby, means for preventing the rear end of the apron from being carried rearward during the first portion of the rearward working movement of the carriage, and means for drawing upon the apron so as to tighten the same after the rear end of the apron begins to move rearward with the carriage, substantially as shown and described.

9. In a cigar bunching machine, the combination with a carriage reciprocating in a plane, of a rolling-bed, a bunching-roller, a bunch-rolling apron mounted upon the reciprocating carriage and carried wholly thereby, means for preventing the rear end of the apron from changing its position relative to the bunching roller during the closing of the bight, and means for tightening the apron after the closing of the bight, substantially as shown and described.

10. In a cigar bunching machine, the combination with a reciprocating carriage, of a rolling-bed, a bunching-roller, a bunch-rolling apron the working portion of which is elastic throughout its entire width mounted upon the carriage and carried wholly thereby, positive means for preventing the throwing of the bunch filling from the bight during the first rearward working movement of the carriage, and means for drawing upon the front end of the apron in advance of the bight as the carriage continues its rearward working movement after the closing of the bight, substantially as shown and described.

11. In a cigar bunching machine, the combination with a reciprocating carriage, of a rolling-bed, a bunching-roller, a bunch-rolling apron the working portion of which is elastic throughout its entire width mounted upon the carriage and carried wholly thereby, means for preventing change in the relative positions of the rear end of the apron and of the bunching-roller during the first movement of the mechanism in closing the bight, and means for drawing upon the front end of the apron in advance of the bight so as to tighten the same during the rearward working movement of the carriage after the closing of the bight, substantially as shown and described.

12. In a cigar bunching machine, the com-

10 combination with a reciprocating carriage, of a rolling-bed, a bunching-roller, a bunch-rolling apron the working portion of which is elastic throughout its entire width mounted upon the carriage and carried wholly thereby, means for preventing the rear end of the apron from being carried rearward during the first portion of the rearward working movement of the carriage, and means for drawing upon the apron so as to tighten the same after the rearward end of the apron begins to move rearward with the carriage, substantially as shown and described.

15 13. In a cigar bunching machine, the combination with a carriage reciprocating in a plane, a rolling-bed, a bunching-roller, a bunch-rolling apron the working portion of which is elastic throughout its entire width mounted upon the reciprocating carriage and carried wholly thereby, means for preventing the rear end of the apron from changing its position relative to the bunching roller during the closing of the bight, and means for tightening the apron after the closing of the bight, substantially as shown and described.

20 14. In a cigar bunching machine, the combination with a reciprocating carriage, of a rolling-bed, a bunching-roller, a bunch-rolling apron mounted upon the carriage and carried wholly thereby and supported wholly thereon so as to move bodily therewith, and means for automatically tightening the apron during the rearward working movement of the carriage while forming the bunch, substantially as shown and described.

25 15. In a cigar bunching machine, the combination with a reciprocating carriage, of a rolling-bed, a bunching-roller, a bunch-rolling apron the working portion of which is elastic throughout its entire width, mounted upon and carried wholly by the carriage and supported wholly thereon so as to move bodily therewith, and means for automatically tightening the apron during the rearward working movement of the carriage while forming the bunch, substantially as shown and described.

30 16. In a cigar bunching machine, the combination with a reciprocating carriage, of a rolling-bed, a bunching-roller, a bunch-rolling apron mounted upon the carriage and carried wholly thereby, and supported wholly thereon so as to move bodily therewith means for preventing change in the relative positions of the bunching-roller and the rear end of the apron during the first movement of the mechanism in closing the bight and means for automatically tightening the apron during the rearward working movement of the carriage after the closing of the bight, substantially as shown and described.

35 17. In a cigar-bunching-machine, the combination with a support, of a carriage mounted upon the support and reciprocating through a plane, a rolling-bed mounted upon the carriage, a bunch-rolling-apron, a bunching-roller, a yielding connection or connections by which the rear of the apron is secured to

the rear of the reciprocating carriage, means for forcing such connection or connections toward the front of the carriage to slacken the apron, means secured to the support for stopping such yielding connection or connections short of the extreme forward movement of the carriage, and means for automatically tightening the apron during the rearward working movement of the carriage, substantially as shown and described.

40 18. In a cigar-bunching-machine, the combination with a support, of a carriage mounted upon the support and reciprocating through a plane, a rolling-bed mounted upon the carriage, a bunching-roller, a bunch-rolling-apron, a yielding connection or connections by which the rear of the apron is secured to the rear of the reciprocating carriage, means for forcing such connection or connections toward the front of the carriage to slacken the apron, means secured to the support for stopping such yielding connection or connections short of the extreme forward movement of the carriage, and means for automatically drawing the forward end of the apron to the rear beneath the rolling-bed during the rearward working movement of the carriage so as to tighten such apron, substantially as shown and described.

45 19. In a cigar-bunching-machine, the combination with a support, of a carriage mounted upon such support and reciprocating through a plane, a rolling-bed, a bunching-roller, a bunch-rolling-apron the working portion of which is elastic throughout the entire width thereof, a yielding connection or connections by which the rear of the apron is secured to the rear of the reciprocating carriage, means for normally facing such connection or connections toward the front of the carriage to slacken the apron, means secured to the support for stopping such yielding connection or connections short of the extreme forward movement of the carriage, and means for automatically drawing upon the forward end of the apron so as to tighten the same during the rearward working movement of the carriage, substantially as shown and described.

50 20. In a cigar-bunching-machine, the combination with a reciprocating carriage, of a rolling-bed, a bunching-roller, a bunch-rolling-apron, a yielding connection or connections by which one end of such apron is secured to the carriage for the purpose stated, means for limiting the movement of such connection or connections to less than the full forward movement of the carriage, and means for drawing upon the opposite end of the apron during the rearward or working movement of the carriage so as to tighten the same, substantially as shown and described.

55 21. In a cigar-bunching-machine, the combination with a reciprocating carriage, of a bunching-roller, a rolling-bed, a bunch-rolling-apron, a sliding bracket or brackets mounted upon the carriage and in connection with one end of the apron, a spring or springs

24 by which such bracket or brackets are normally forced toward the front of the carriage, and a stop or stops 23 for limiting the forward movement of the bracket or brackets for the purpose stated mounted upon the support for the carriage, substantially as shown and described.

22. In a cigar-bunching-machine, the combination, with a reciprocating carriage mounted upon a suitable support, of a bunching-roller, a rolling-bed, a bunch-rolling-apron, a movable bracket or brackets 12 mounted upon the carriage, and in connection with one end of the apron, a spring or springs 24 by which such bracket or brackets are normally forced toward the front of the carriage, a stop or stops 23 mounted upon the support for the carriage, by which the forward movement of the bracket or brackets is limited to less than the full forward movement of the carriage, and means for automatically tightening the apron during the rearward movement of the carriage, substantially as shown and described.

23. In a cigar-bunching-machine, the combination with a bunch-rolling-apron the working portion of which is elastic throughout its entire width, of a rolling-bed, a bunching-roller, and means for tightening and stretching the apron after the bight is closed, substantially as shown and described.

24. In a cigar-bunching-machine, the combination with a reciprocating carriage, of a bunching-roller, a rolling-bed, a bunch-rolling-apron, a shaft 26 mounted in the carriage, a cam or cams 33, mounted upon the shaft 26 and in actuating connection with the apron in such manner as to tighten the same when actuated, a cam-lever 28, secured to the shaft 26, and a cam-piece 30 for actuating the cam-lever 28, substantially as shown and described.

25. In a cigar-bunching-machine, the combination with a reciprocating carriage, of a bunching-roller, a rolling-bed, a bunch-rolling-apron the working portion of which is elastic throughout the entire width thereof, a shaft 26, a cam or cams 33 mounted upon the shaft, mechanism connecting the cam or cams 33 with the apron in such manner that the actuation of the cam or cams will tighten and stretch such apron, a cam-lever 28 secured to the shaft 26, and a cam-piece 30 adjacent to the cam-lever 28 by which the same is actuated, substantially as shown and described.

26. In a cigar-bunching-machine, the combination with a reciprocating carriage, of a rolling-bed, a bunching-roller, a bunch-rolling-apron one end of which is secured to such carriage by a yielding connection, a shaft 26 mounted upon the carriage, a cam or cams 33 mounted upon the shaft 26, mechanism connecting the end of the apron which is unconnected with the yielding connection with the cam or cams 33, and means for actuating the shaft 26 as the carriage is reciprocated, substantially as shown and described.

27. In a cigar-bunching-machine, the com-

ination with a reciprocating carriage, of a rolling-bed, a bunching-roller, a bunch-rolling-apron one end of which is secured to such carriage by a yielding connection, a shaft 26 mounted upon the carriage, a cam or cams 33 mounted upon the shaft 26, mechanism connecting the end of the apron that is unconnected with the yielding connection with the cam or cams 33, a cam-lever 28 secured to the shaft 26, and a cam-piece 30 adjacent to such cam-lever for actuating the same, substantially as shown and described.

28. In a cigar-bunching-machine, the combination with a reciprocating carriage, of a rolling-bed, a bunching-roller, located above the rolling-bed, a bunch-rolling-apron the forward end of which is secured to the reciprocating carriage by a yielding connection, means for limiting the forward movement of the yielding connection to less than the entire forward movement of the carriage, and means for automatically drawing the forward end of the apron toward the rear underneath the rolling-bed as the carriage is moved to the rear while working, substantially as shown and described.

29. In a cigar-bunching-machine, the combination with a reciprocating carriage, of a rolling-bed formed of a sheet of flexible material mounted upon the carriage, and means for tightening and loosening such sheet, substantially as shown and described.

30. In a removable shaper for cigar-bunching-machines, the combination with a suitable block having a mold-cavity extending through the same, of an ejecting-plunger located in the mold-cavity and adapted to be reciprocated in the same, means for normally holding such plunger in a retracted position with the end thereof in the mold-cavity, and a movable-piece 53 adapted to close the open side of the mold-cavity, substantially as shown and described.

31. In a removable shaper for cigar-bunching-machines, the combination with a suitable block having a mold-cavity extending through the same, of an ejecting-plunger located in such cavity so that one end thereof may be pushed entirely through the same, and suitable springs by which such plunger is kept normally in a retracted position with the end thereof within the cavity so as to form one wall of such cavity, and a movable piece 53 for closing the open side of the cavity so as to hold the filler-tobacco therein when the shaper is held in the ejecting position, substantially as shown and described.

32. In a removable shaper for cigar-bunching-machines, the combination with a suitable block having a mold-cavity extending through the same, of an ejecting-plunger located in the mold-cavity the end of which is adapted to be pushed entirely through the mold-cavity, rods 49 secured at the lower ends to the mold-block, the cross-bar 48 secured to the top of the plunger and having holes in the ends through which pass said rods 49, adjust-

- able nuts on the rods 49 above the cross-bar 48, a spring or springs 52 interposed between the mold-block and the cross-bar, and a swinging movable piece 53 by which the open side of the mold-cavity is closed and adapted to be forced open by the pressure of the ejecting-plunger when the same is forced down through the mold-cavity, substantially as shown and described.
33. In a removable shaper for cigar-bunching-machines, the combination with a block having a mold-cavity extending through the same, and having the extending end-portions 44, of an ejecting-plunger located in the mold-cavity the end of which is adapted to be pushed entirely through the same, means for normally holding such plunger in a retracted position with the end thereof within the cavity so as to form one wall thereof, and a movable-piece 53 adapted to close the open side of the mold-cavity and to be pushed open by the end of the plunger when the same is pushed down through the cavity, substantially as shown and described.
34. In a removable shaper for cigar-bunching-machines, the combination with a suitable block having a mold-cavity extending through the same, of a hinged bottom-piece 53, an ejecting-plunger located in the mold-cavity, and a portion of the block forming one side wall of the mold-cavity separated from the rest of the block so as to be moved aside, substantially as shown and described.
35. In a removable shaper for cigar-bunching-machines, the combination with a suitable block having a mold-cavity extending through the same, of a hinged bottom-piece 53, an ejecting-plunger reciprocating in the cavity, and a portion of the block forming one side wall of such cavity separated from the rest of the block and hinged thereto so as to be swung aside, substantially as shown and described.
36. In a removable shaper for cigar-bunching machines, the combination with a suitable block having a mold-cavity extending through the same, of an ejecting-plunger reciprocating in such cavity, a portion of the block forming one side wall of the cavity being separated from the rest of the block and hinged thereto so as to be swung open, and a piece 53 for covering the open end of the mold-cavity hinged to the swinging piece of the block, substantially as shown and described.
37. A removable shaper for cigar-bunching machines, having an ejecting plunger reciprocating in the mold-cavity, a hinged wall to such cavity, and a hinged bottom-piece therefor, substantially as shown and described.
38. In a cigar-bunching machine, the combination with a bunch-rolling-apron the working portion of which is elastic throughout its entire width, of a rolling-bed, a bunching-roller of the form of a right cylinder, and means for tightening and stretching the apron after the bight is closed, substantially as shown and described.
39. In a cigar-bunching-machine, the combination with a bunch-rolling-apron the working portion of which is elastic throughout its entire width, of a rolling-bed, a bunching-roller of the form of a right cylinder, means for closing the bight without disturbing the filler tobacco therein, and means for tightening and stretching the apron after the bight is closed, substantially as shown and described.
40. In a cigar-bunching-machine, the combination with a bunch-rolling-apron, the working portion of which is elastic throughout its entire width, of a rolling-bed, a bunching-roller substantially in the form of a right cylinder, means for preventing change in the relative positions of the rear end of the apron and of the bunching-roller during the closing of the bight, and means for drawing upon the front end of the apron so as to tighten and stretch the same after the bight is closed, substantially as shown and described.
41. In a cigar-bunching-machine, the combination with a reciprocating carriage, of a rolling-bed mounted thereon, a bunch-rolling-apron the working portion of which is elastic throughout its entire width mounted upon and carried wholly by the reciprocating carriage, a bunching-roller substantially in the form of a right cylinder, means for preventing the rear end of the apron from moving rearward with the carriage while the bight is being closed and for carrying it rearward after the bight is closed, and means for drawing upon the front end of the apron so as to tighten and stretch the same as the carriage moves rearward after the bight is closed, substantially as shown and described.
42. In a cigar-bunching-machine, the combination with a bunch-rolling-apron the working portion of which is elastic throughout its entire width, of a rolling-bed, a bunching-roller, means for closing the bight without disturbing the filler tobacco therein, and means for tightening and stretching the apron after the bight is closed, substantially as shown and described.
43. In a cigar-bunching-machine, the combination with a bunch-rolling-apron, the working portion of which is elastic throughout its entire width, of a rolling-bed, a bunching-roller, means for preventing change in the relative positions of the rear end of the apron and of the bunching roller during the closing of the bight, and means for drawing upon the front end of the apron so as to tighten and stretch the same after the bight is closed, substantially as shown and described.
44. In a cigar-bunching-machine, the combination with a reciprocating carriage, of a rolling-bed mounted thereon, a bunch-rolling-apron the working portion of which is elastic throughout its entire width mounted upon and carried wholly by the reciprocating carriage, a bunching-roller, means for prevent-

ing the rear end of the apron from moving rearward with the carriage while the bight is being closed and for carrying it rearward after the bight is closed, and means for drawing upon the front end of the apron so as to tighten and stretch the same as the carriage moves rearward after the bight is closed, substantially as shown and described.

Signed at the city and county of New York, in the State of New York, this 6th day of January, A. D. 1894.

JOSEPH DELA MAR.

Witnesses:

F. DE LYSLE SMITH,  
LEON KLEIN.