

(19) World Intellectual Property Organization
International Bureau



(43) International Publication Date
5 December 2002 (05.12.2002)

PCT

(10) International Publication Number
WO 02/096278 A1

- (51) International Patent Classification⁷: **A61B 1/32**
- (21) International Application Number: PCT/US02/17285
- (22) International Filing Date: 31 May 2002 (31.05.2002)
- (25) Filing Language: English
- (26) Publication Language: English
- (30) Priority Data:
60/295,408 31 May 2001 (31.05.2001) US
- (71) Applicant: **NEOSEED TECHNOLOGY LLC** [US/US];
The Presidio, Old Army Headquarters, Building 220, Suite
120, P.O. Box 29450, San Francisco, CA 94129 (US).
- (72) Inventors: **HOGENDIJK, Michael**; 501 Forest Avenue
#904, Palo Alto, CA 94301 (US). **GREEN, Thomas, C.**;
11071 Arroyo Beach Place, S.W. Seattle, WA 98146 (US).

GANDIONCO, Isidro, M.; 36520 Alder Ct., Fremont, CA 94536 (US). **BOUCHER, Ryan, P.**; 1424 Clay Street, San Francisco, CA 94109 (US). **BELMAN, Yuri**; 241 Arriba Drive, Apt. 4, Sunnyvale, CA 94086 (US).

- (74) Agents: **PISANO, Nicola, A.** et al.; Fish & Neave, 1251 Avenue of the Americas, New York, NY 10020 (US).
- (81) Designated States (*national*): AE, AG, AL, AM, AT, AU, AZ, BA, BB, BG, BR, BY, BZ, CA, CH, CN, CO, CR, CU, CZ, DE, DK, DM, DZ, EC, EE, ES, FI, GB, GD, GE, GH, GM, HR, HU, ID, IL, IN, IS, JP, KE, KG, KP, KR, KZ, LC, LK, LR, LS, LT, LU, LV, MA, MD, MG, MK, MN, MW, MX, MZ, NO, NZ, OM, PH, PL, PT, RO, RU, SD, SE, SG, SI, SK, SL, TJ, TM, TN, TR, TT, TZ, UA, UG, UZ, VN, YU, ZA, ZM, ZW.
- (84) Designated States (*regional*): ARIPO patent (GH, GM, KE, LS, MW, MZ, SD, SL, SZ, TZ, UG, ZM, ZW),

[Continued on next page]

(54) Title: PROSTATE VISUALIZATION DEVICE AND METHODS OF USE

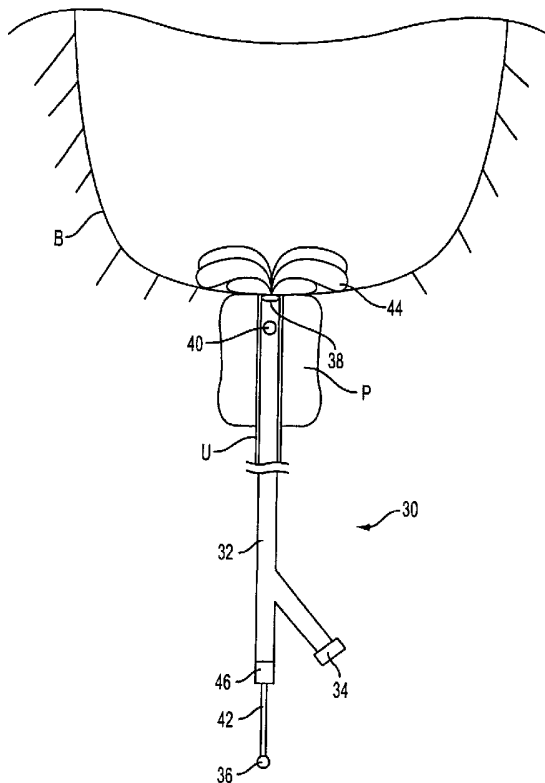

(57) Abstract: Methods and apparatus (30) are provided for improved administration of brachytherapy in the treatment of prostate disease. More particularly, a prostate visualization device is provided comprising a catheter (32) coupled to at least one deployable member (44) at the distal end of the catheter (32). The deployable member (44) is preferably manufactured from a shape memory alloy having a petal-shaped configuration suitable for engaging and defining the proximal region of a patient's bladder (B). The deployable member (44) may comprise tubing (82) filled with air or other radiopaque agents to facilitate ultrasonic imaging of the deployable members (44) near the bladder/prostate junction.



WO 02/096278 A1



Eurasian patent (AM, AZ, BY, KG, KZ, MD, RU, TJ, TM),
European patent (AT, BE, CH, CY, DE, DK, ES, FI, FR,
GB, GR, IE, IT, LU, MC, NL, PT, SE, TR), OAPI patent
(BF, BJ, CF, CG, CI, CM, GA, GN, GQ, GW, ML, MR,
NE, SN, TD, TG).

Published:

- *with international search report*
- *before the expiration of the time limit for amending the claims and to be republished in the event of receipt of amendments*

Declarations under Rule 4.17:

- *as to applicant's entitlement to apply for and be granted a patent (Rule 4.17(ii)) for all designations*
- *as to the applicant's entitlement to claim the priority of the earlier application (Rule 4.17(iii)) for all designations*

For two-letter codes and other abbreviations, refer to the "Guidance Notes on Codes and Abbreviations" appearing at the beginning of each regular issue of the PCT Gazette.

PROSTATE VISUALIZATION DEVICE AND METHODS OF USE

Reference to Related Application

[0001] The present application claims the benefit of the filing date of U.S. provisional application Serial
5 No. 60/295,408, filed May 31, 2001, the disclosure of which is incorporated herein by reference in its entirety.

Field Of The Invention

10 [0002] This invention relates to improved apparatus and methods for the treatment of prostate cancer. More particularly, the present invention provides a prostate visualization device having at least one deployable member suitable for imaging the bladder/prostate
15 junction, and methods of use.

Background Of The Invention

[0003] Excluding nonmelanoma skin cancers, prostate cancer is the most common cancer afflicting American men.
20 The American Cancer Society estimates that over 180,00 new cases will be diagnosed in the U.S. in the year 2000 alone, and that nearly 32,000 people will die from the

- 2 -

disease. Prostate cancer is second only to lung cancer as the leading cause of cancer death in men, accounting for roughly 11%.

[0004] Prostate cancer is defined as malignant tumor growth within the prostate gland. Its cause is unknown, although high dietary fat intake and increased testosterone levels are believed to be contributory factors. A letter scale ("A" through "D"), which accounts for the location of the cancer, is commonly used to classify the stage of disease. In Stage A, the tumor is not palpable but is detectable in microscopic biopsy. Stage B is characterized by a palpable tumor confined to the prostate. By Stage C, the tumor extends locally beyond the prostate with no distant metastasis. By Stage D, cancer has spread to the regional lymph nodes or has produced distant metastasis.

[0005] In the early stages, prostate cancer is most commonly treated by either prostate removal or by brachytherapy. More advanced cases are treated by hormonal manipulation or orchiectomy to reduce testosterone levels and curb spreading of the disease, by chemotherapy, or by external beam radiation therapy.

[0006] With regard to treatment of early stage prostate cancer, the state of the art has several drawbacks. Radical prostatectomy is often recommended for treatment of localized stage A and B prostate cancers. Under general or spinal anesthesia, an incision is made through a patient's abdomen or perineal area, and the diseased prostate is removed. The procedure is lengthy, especially if a lymph node dissection is simultaneously performed, and requires a hospital stay of 2-5 days. Possible complications include impotence and urinary incontinence.

- 3 -

[0007] Internal radiation therapy or brachytherapy has recently been developed and holds great promise for the treatment of early stage prostate cancer. Radioactive pellets or seeds of, for example, iodine-125, palladium-
5 103, or iridium-192, are deposited directly into the prostate through needle placement. U.S. Patent No. 5,928,130 to Schmidt provides a slightly modified example of such a needle device. Imaging techniques, such as
10 transrectal ultrasound, CT scans, or MRI, are used to accurately guide placement of the radioactive material. Advantageously, radiation from the brachytherapy seeds is administered directly to the prostate with less damage to surrounding tissues, delivering a substantially higher
15 radiation dosage to the prostate than to the surrounding tissues, as compared to external beam radiation therapy. The procedure need only be performed once, and impotence and urinary incontinence complications are significantly reduced, as compared to prostate removal procedures.

[0008] The seeds, which are permanently implanted,
20 give off radiation for weeks or months. Their presence causes little discomfort, and they remain in the prostate after decay of the radioactivity. For several weeks following needle insertion, patients may experience pain in the perineal area, and urine may have a red-brown
25 discoloration.

[0009] Although, when performed correctly, brachytherapy may provide several benefits when compared to prostate removal and other techniques, current
apparatus and methods for delivering the seeds to target
30 locations within the prostate are somewhat crude and are subject to practitioner error. The current method of identifying the depth of needle insertion is by ultrasound imaging. The junction of the base of the

prostate and the bladder provides a common reference plane for needle insertion. Identifying this critical reference "base" plane is critical to proper needle and seed placement.

5 [0010] One previously known technique for imaging the base plane is to visualize the plane in either transverse or sagittal ultrasound imaging. Injection of contrast agent may facilitate imaging. A catheter, such as a standard Foley catheter, may be inserted into the
10 patient's urethra proximal of the junction. Contrast agent comprising aerated K-Y jelly and water, may then be injected through an end port of the catheter. The agent moves distally towards the patient's bladder and is visible to an ultrasound probe, positioned in the
15 patient's rectum, thereby facilitating imaging.

[0011] Attempts have been made to improve Foley catheters, as well as to facilitate improved imaging within a body lumen. For example, U.S. Patent No. 5,715,825 to Crowley provides an acoustic imaging
20 catheter with an inflatable dilation balloon and an ultrasound transducer. However, while Crowley may provide improved imaging, the device is mechanically and electrically complex, and is therefore costly. U.S. Patent No. 5,916,153 to Rhea, Jr. provides a
25 multifunction, modified Foley catheter. The device described in that patent, however, does not improve on current junction imaging techniques.

[0012] In view of the drawbacks associated with previously-known methods and apparatus for
30 bladder/prostate junction imaging, it would be desirable to provide methods and apparatus that overcome such drawbacks.

- 5 -

[0013] It further would be desirable to provide methods and apparatus that provide reliable imaging of the bladder/prostate junction.

[0014] It still further would be desirable to provide
5 methods and apparatus that may be used in conjunction with standard brachytherapy apparatus.

Summary Of The Invention

[0015] In view of the foregoing, it is an object of
10 the present invention to provide methods and apparatus for bladder/prostate junction imaging that overcome drawbacks associated with previously-known methods and apparatus.

[0016] It is also an object of the present invention
15 to provide methods and apparatus that provide reliable imaging of the bladder/prostate junction.

[0017] It still further is an object to provide methods and apparatus that may be used in conjunction with standard brachytherapy apparatus.

[0018] These and other objects of the present
20 invention are accomplished by providing methods and apparatus for bladder/prostate junction imaging comprising a catheter having at least one distally deployable member that engages and defines the proximal
25 region of the bladder. The deployable member is preferably constructed from a shape memory material that forms a petal-shaped configuration upon deployment. The deployable member is deployed within the patient's bladder, and may be retracted proximally to conform to
30 the proximal wall of a patient's bladder. Gas pockets may be provided around the deployable member to enhance visibility with an ultrasound probe. Additionally, echo-

contrast agent may be injected to the region to facilitate reliable imaging.

[0019] In a preferred embodiment, the deployable member comprises a plurality of petal-shaped Nitinol wires affixed to the distal end of a plunger that is coupled to a multi-lumen catheter. The catheter may include a deployment lumen, a bladder drainage lumen, a contrast injection lumen, and a prostatic therapy lumen. The catheter is advanced through a patient's urethra into the patient's bladder. The deployable member is deployed by advancing the plunger distally within the deployment lumen. Upon deployment within the bladder, the plunger is proximally retracted until the deployable member engages the proximal wall of the bladder. Echo-contrast agent then may be injected into a space near the bladder/prostate junction. Ultrasonic imaging may then proceed, often with an ultrasound probe positioned in the patient's rectum. Urine also may be emptied from the bladder via the bladder drainage lumen, and the patient's prostate may be accessed via the prostatic therapy lumen.

[0020] The deployment lumen may be used in combination with any of the drainage, contrast, and prostatic therapy lumens. In alternative embodiments, one or more catheter lumens may be configured to serve more than one function. For example, a single lumen catheter having only one distal outlet port may be provided whereby one or more proximal ports are in communication with the outlet port via the single lumen. In this embodiment, the single lumen of the catheter allows for passage of the deployable member, fluid injection, fluid drainage and delivery of prostatic therapy devices or therapeutic agents.

[0021] Additionally, tubing may cover the deployable member to form gas pockets around the deployable member such that the gas enhances ultrasonic imaging of the bladder/prostate junction. The tubing may comprise a
5 variety of shapes and sizes to facilitate imaging of the deployable member.

[0022] Methods of using the present invention are also provided.

10 Brief Description of the Drawings

[0023] Additional objects and advantages of the invention will be apparent from the following description, the appended claims, and the accompanying drawings, in which like reference characters refer to
15 like parts throughout, and in which:

[0024] FIG. 1 is a schematic view of a prior art method of performing brachytherapy;

[0025] FIG. 2 is a schematic view detailing the prior art method of imaging the bladder/prostate junction in
20 greater detail;

[0026] FIGS. 3A-3C are, respectively, a side view of apparatus constructed in accordance with the present invention in a collapsed delivery state, a sectional view of the apparatus through section line A--A of FIG. 3A,
25 and a side view, partly in section, of the apparatus in an expanded deployed state;

[0027] FIG. 4 is a schematic view, partly in cross-section, demonstrating a method of using the apparatus of FIG. 3 to image a patient's bladder/prostate junction;

30 [0028] FIG. 5 illustrates an actuation mechanism for the deployable member;

[0029] FIGS. 6 illustrate alternative embodiments for enhancing ultrasonic imaging of the deployable member;

[0030] FIG. 7 illustrates an alternative mechanism for actuating the deployable member;

[0031] FIGS. 8A-8B are, respectively, a side view of an alternative apparatus constructed in accordance with the present invention in a collapsed delivery state, and a sectional view of the apparatus through section line B-B of FIG. 8A; and

[0032] FIGS. 9A-9B are, respectively, a side view of a further alternative embodiment constructed in accordance with the present invention in a deployed state, and a cross-sectional view through line C--C of FIG. 9A.

Detailed Description Of The Invention

[0033] The present invention provides methods and apparatus for improved administration of brachytherapy. More particularly, the present invention provides a prostate visualization device comprising at least one distally deployable member that engages and defines the proximal wall of a patient's bladder. The device is preferably coupled to a catheter to facilitate imaging of the patient's bladder/prostate junction.

[0034] Referring to FIGS. 1 and 2, a prior art method of performing brachytherapy is described. The method and apparatus are as taught by Peter Grimm, DO, in a pamphlet entitled, "Ultrasound Guided Implantation of the Prostate: A Practical Review Course." As seen in FIG. 1, brachytherapy apparatus 10 comprises transrectal ultrasound probe 12, guide block 14, needle 16, plunger 18, and radioactive seeds 20. Ultrasound probe 12 is advanced through a patient's rectum R to facilitate imaging of the patient's prostate P. Prostate P surrounds urethra U and is just proximal of bladder B. An ultrasonic image of a junction between the prostate

- 9 -

and the bladder is acquired, as described hereinbelow with respect to FIG. 2. Needle 16, loaded with seeds 20 and plunger 18, is then advanced through guide block 14, through the patient's perineum **Pe**, and into prostate **P**, where needle 16 is retracted while plunger 18 is held stationary to sew the seeds in a line within prostate **P**.

[0035] With reference to FIG. 2, the imaging aspect of the apparatus and method of FIG. 1 is described in greater detail. A catheter, such as a standard Foley catheter, is inserted into the patient's urethra proximal of the patient's bladder/prostate junction. A combination of water and KY jelly is then injected through an end port of the catheter. The combination moves distally towards the patient's bladder and appears to ultrasound probe 12 as contrast agent. Ultrasound probe 12 then provides signals that are converted by a previously known ultrasound system to display ultrasonic image 22 of base plane **BP**, which is located tangent to the distal surface of prostate **P**, i.e. at the prostate/bladder junction. All positions within the prostate are determined relative to base plane **BP** during the brachytherapy procedure.

[0036] Ultrasonic imaging and location determination of base plane **BP** may be unreliable due to irregular ultrasonic images dependent on a density of the water/KY jelly combination at a given location, as well as flow conditions within the bladder and urethra. Thus, there exists a need for reliable apparatus and methods for bladder/prostate junction imaging.

[0037] Referring now to FIGS. 3, a first embodiment of apparatus constructed in accordance with the present invention is described. Apparatus 30 comprises catheter 32 and plunger 42 having handle 36. Plunger 42 may span

- 10 -

the approximate length of catheter 32 such that it is directly affixed to deployable member 44 of FIG. 3C. Alternatively, plunger 42 may be affixed to the proximal end of a connector, and the distal end of the connector
5 may be affixed to deployable member 44, as described in FIG. 5 hereinbelow.

[0038] Catheter 32 further comprises deployment lumen 33 and contrast lumen 35. A second contrast lumen 37 may be provided, and contrast lumens 35 and 37 may be
10 separated by optional dividing wall 39 to enhance catheter stability during injection of the contrast agent.

[0039] Deployment lumen 33 extends between proximal deployment port 46 and distal deployment port 38.
15 Proximal deployment port 46 is preferably a hemostatic port, e.g., a Touhy-Borst connector, that enables plunger 42 to slide longitudinally through the port while inhibiting fluid transfer. Contrast lumens 35 and 37 extend between proximal contrast port 34 and distal
20 contrast port 40, which is located proximal of distal deployment port 38. Catheter 32, excluding plunger 42 and handle 36, preferably comprises a total length of 30-50 cm.

[0040] Deployable member 44 is expandable from a
25 collapsed delivery configuration within deployment lumen 33, to an expanded deployed configuration, as shown in FIG. 3C. In the deployed configuration, deployable member 44 is suitable for engaging and defining the proximal wall of a patient's bladder. Deployment member
30 44 preferably is provided in a petal or hoop shape, and may comprise a shape memory material, e.g., a Nickel-Titanium alloy (commonly known in the art as Nitinol). The predetermined shape is set by constraining the

- 11 -

Nitinol element on a mandrel or fixture of the desired shape, then applying an appropriate heat treatment.

[0041] Deployable member 44 preferably is provided in a concave configuration with respect to the
5 bladder/prostate junction. The member is flexible such that it may automatically conform to the shape of the proximal wall of the bladder, without imposing excessive pressure on the prostate or bladder upon retraction of the member against the proximal wall of the bladder. In
10 a preferred embodiment, deployable member 44 comprises twelve petal-shaped members, although greater or fewer numbers of petal-shaped members may be used. The petal-shaped members may either overlap circumferentially or be spaced apart circumferentially when deployed.

[0042] Referring now to FIG. 4, a method of using apparatus 30 in accordance with the principles of the present invention is described. Catheter 32 is advanced through a patient's urethra **U** into bladder **B**, with
15 deployable member 44 in a collapsed delivery configuration. Plunger 42 then is advanced distally, e.g., by pushing handle 36 of plunger 42 distally while retaining catheter 32 stationary, such that deployable member 44 extends beyond distal deployment port 38 of
20 catheter 32. Deployable member 44 then self-expands to a predetermined, deployed configuration, as shown in FIG. 4.

[0043] Catheter 32 then is retracted out of bladder **B** to a desired position within urethra **U**. Alternatively, catheter 32 first may be placed at the desired position
30 within the urethra and plunger 42 then is advanced distally to push deployable member 44 through the remaining portion of the urethra and into the bladder. With deployable member 44 in the expanded configuration,

- 12 -

plunger 42 is retracted proximally until deployable member 44 engages a proximal region of bladder B.

[0044] Echo-contrast agent then may be injected through proximal contrast port 34 so that it exits distal contrast port 40. Contrast lumens 35 and 37, and ports 34 and 40, are preferably dimensioned in a manner that accounts for the viscosity of the agent. Once the contrast agent has been injected, apparatus 30 facilitates reliable ultrasonic imaging with ultrasound probe 12 inserted through the patient's rectum R, as shown in FIG. 1, and enables determination of a reliable reference plane, as depicted in FIG. 2. The reference plane may be used to conduct or to prepare for brachytherapy treatment of prostate cancer, in the manner discussed hereinabove.

[0045] With respect to FIG. 5, a mechanism for actuating the deployable member is described. Plunger 42 of FIG. 3 may be affixed to connector 50 via adhesive 52. Plunger 42 preferably comprises a relatively rigid material suitable for longitudinally sliding through proximal deployment port 46. Connector 50 preferably comprises a relatively elastic material that may adapt to the curvature of catheter 32, i.e., during transurethral insertion of catheter 32. Connector 50 may, for example, comprise a coil, a straight wire, a plastic rod, or any other configuration having elastic properties.

[0046] Connector 50 may be affixed to deployable member 44 via adhesive 54. Alternatively, connector 50 may be omitted and plunger 42 may span the approximate length of catheter 32 such that it is directly affixed to deployable member 44. In this embodiment, plunger 42 may comprise a relatively rigid proximal section and a more

elastic distal section that spans the majority of the length of catheter 32.

[0047] Referring now to FIGS. 6, alternative embodiments for enhancing ultrasonic imaging of the deployable member are described. In FIG. 6A, deployable member 81 is preferably constructed from shape memory wire 80 that expands to the deployed, petal-shape illustrated. Shape memory wire 80 may be covered with biocompatible tubing 82.

10 [0048] Biocompatible tubing 82 may be affixed to wire 80 by a biocompatible adhesive 84. The inner diameter of tubing 82 is sized to form gas pocket **G** around wire 80. Gas pocket **G** may comprise air, or any other radiopaque material, to enhance radiopaque imaging of deployable member 81 within the body.

[0049] Alternatively, tubing 92 may completely surround deployable member 91 and may extend toward the proximal end of catheter 32, as shown in FIG. 6B. In this embodiment, tubing 92 surrounds wire 90 and plunger 20 93 such that gas pocket **G** is visible along the length of catheter 32. An optional inflation port (not shown) may be added to the apparatus of FIG. 3, and the inflation port may be coupled to the tubing such that additional gas **G** may be added to or removed from within the tubing.

25 [0050] FIG. 6C illustrates deployable member 101 comprising various tubing configurations that are intermittently spaced around deployable member 101. Tubing pieces 102 are affixed at spaced increments around wire 100, each piece of tubing being suitable for housing gas pockets **G** to facilitate ultrasonic imaging of 30 deployable member 101. Intermittently spacing the tubing around wire 100 may provide less resistance as wire 100 deploys to its predetermined configuration. Similarly,

- 14 -

smaller tubing pieces 106 or rounded tubing pieces 104 may be intermittently spaced around deployable member 101.

[0051] In FIG. 6D, deployable member 111 comprises
5 plurality of interwoven wires 112. Plurality of interwoven wires 112 are loosely wrapped such that gaps exist between the wires. Advantageously, these gaps may trap gas bubbles **G** to facilitate ultrasonic imaging of deployable member 111 near the bladder/prostate junction.

10 [0052] In FIG. 6E, deployable member 121 comprises a single piece of tubing 122 configured to deploy to a predetermined shape. In this embodiment, the proximal end of tubing 122 is sealed by plug 124 to confine contrast gas **G**. Alternatively, plug 124 may be omitted
15 and tubing 122 may be coupled to a proximal inflation port (not shown) such that a radiopaque contrast agent may be injected into or removed from tubing 122.

[0053] In FIG. 7, an alternative mode of actuating deployable member 131 is depicted. Deployable member 131
20 comprises wire 130 having hinging member 134. Hinging member 134 is initially constrained within catheter 132 during transurethral insertion of the device, as illustrated by the dotted line outline of position **X**. Upon positioning, wire 130 is advanced distally, e.g., by
25 distally advancing plunger 42 of FIG. 1, such that hinging member 134 is advanced distal to port 138. Hinges 136 provide torsional rotation that allow hinging member 134 to expand to a curved configuration, as illustrated by position **Y**, suitable for conforming to the
30 proximal wall of the patient's bladder.

[0054] Referring now to FIGS. 8, a further alternative embodiment of the catheter of the present invention is described. Catheter 152 comprises deployment lumen 153,

prostatic therapy lumen 155, contrast lumen 157, and bladder drainage lumen 159. Deployment lumen 153 extends between proximal deployment port 158, e.g., a Touhy-Borst connector, and distal deployment port 170. Contrast lumen 157 extends between proximal contrast port 160 and distal contrast port 166, which is located proximal of distal deployment port 170. Prostatic therapy lumen 155 extends between proximal prostate port 164 and distal prostate port 165, which is located proximal of distal contrast port 166. Bladder drainage lumen 159 extends between proximal drainage port 162 and distal drainage port 168, which is located adjacent to distal deployment port 170.

[0055] Urine and other fluids may be emptied from the patient's bladder **B** of FIGS. 8 during and after imaging via bladder drainage lumen 168. Urine enters distal drainage port 168, passes through drainage lumen 159 and exits the patient's body through proximal drainage port 162.

[0056] Prostatic therapy lumen 155 provides access to the patient's prostate **P** of FIGS. 8. Therapeutic agents or interventional devices may be inserted into lumen 155 through proximal prostate port 164, and deposited into the patient's prostate **P** via distal prostate port 165. Apparatus 150 thus may be used for a variety of procedures which will be apparent to those of skill in the art and of which brachytherapy is only one example. Furthermore, it should be appreciated that deployment lumen 153 and its respective ports may be used in conjunction with any of the other three lumens described hereinabove, and their respective ports.

[0057] Referring now to FIGS. 9A-9B, a further alternative embodiment of a catheter of the present

invention is described. In FIG. 9A, apparatus 230 comprises catheter 232 having plunger 242 disposed within lumen 233 thereof. Plunger 242 includes handle 236 and is coupled to deployable member 244, for example, via
5 connecting rod 250, as described hereinabove with respect to FIG. 5. In this embodiment, catheter 232 comprises single lumen 233, as shown in FIG. 9B, that is configured to be used as a deployment lumen, contrast lumen, bladder drainage lumen and, optionally, as a prostatic therapy
10 lumen. This configuration eliminates the need for two or more separate lumens, and reduces the overall profile of catheter 232.

[0058] In the embodiment of FIG. 9A, proximal deployment port 246 and proximal contrast port 234
15 preferably are similar to ports 46 and 34 of FIG. 3A, respectively, except that each of ports 246 and 234 communicate with lumen 233. Accordingly, contrast may be injected into proximal contrast port 234, flow through lumen 233 alongside connecting rod 250, and exit through
20 distal outlet port 240, which forms as an opening at the distalmost end of catheter 232. In this embodiment, distal outlet port 240 also serves as the deployment port through which deployable member 244 is extended to self-deploy.

25 [0059] In the embodiment of FIGS. 9, the wire loops forming the petal-shaped members at least partially overlap, thereby enhancing the structural rigidity of the petal-shaped members when deployed. As in the embodiment of FIG. 5, the petal-shaped members preferably comprise a
30 shape-memory biocompatible alloy, such as nickel-titanium.

[0060] Although particular embodiments of the present invention have been described above in detail, it will be

understood that this description is merely for purposes of illustration. Specific features of the invention are shown in some drawings and not in others; this is for convenience only, and any feature may be combined with
5 another in accordance with the invention. Further variations will be apparent to one skilled in the art in light of this disclosure and are intended to fall within the scope of the appended claims.

Claims:

1. . Apparatus for facilitating visualization of a patient's prostate/bladder junction, comprising:
a catheter having proximal and distal ends, a proximal deployment port at the proximal end, a
5 first outlet port at the distal end, and a first lumen extending therebetween;
a plunger having proximal and distal ends, the distal end of the plunger configured to slidably pass through the proximal deployment port; and
10 at least one deployable member coupled to the distal end of the plunger, wherein the deployable member is expandable from a delivery configuration adapted for transurethral insertion, to a deployed configuration adapted for engagement of a proximal
15 portion of the patient's bladder.
2. The apparatus of claim 1 wherein the catheter further comprises a second inlet port, a second outlet port and a second lumen extending therebetween.
3. The apparatus of claim 2 wherein the catheter further comprises a third inlet port, a third outlet port and a third lumen extending therebetween.
4. The apparatus of claim 1 wherein the deployable member comprises at least one wire loop.
5. The apparatus of claim 4 wherein the wire loop has a roughened exterior surface, the roughened exterior surface adapted to entrap gas bubbles to facilitate ultrasonic imaging.
6. The apparatus of claim 4 wherein the wire loop comprises a shape memory material.

7. The apparatus of claim 6 wherein the wire loop consists of a Nickel Titanium alloy.

8. The apparatus of claim 1 wherein the deployable member comprises a petal-shape in the deployed configuration.

9. The apparatus of claim 1 wherein the deployable member comprises a plurality of petal-shaped members that at least partially overlap in the deployed configuration.

10. The apparatus of claim 1 wherein the elasticity of the deployable member enables the deployable member to conform to the proximal wall of the bladder without displacing the bladder wall.

11. The apparatus of claim 1 wherein the deployable member is concave with respect to the proximal wall of the bladder in the deployed configuration.

12. The apparatus of claim 1 further comprising brachytherapy apparatus configured for delivery of radioactive seeds to the patient's prostate, wherein delivery of the seeds is facilitated by
5 ultrasonic imaging of a junction of the patient's prostate and bladder.

13. The apparatus of claim 1 wherein the plunger further comprises a handle affixed to the proximal end of the plunger.

14. The apparatus of claim 1 wherein the plunger comprises a rigid material.

15. The apparatus of claim 1 wherein the plunger comprises a rigid proximal section and an elastic distal section, the elastic distal section suitable for conforming to the curvature of the catheter.

16. The apparatus of claim 1 further comprising a connector having proximal and distal ends, wherein the proximal end of the connector is affixed to the distal end of the plunger, and the distal end of the
5 connector is affixed to the deployable member.

17. The apparatus of claim 16 wherein the connector is a plastic rod.

18. The apparatus of claim 16 wherein the connector has a coiled configuration.

19. The apparatus of claim 16 wherein the connector has a flexible wire configuration.

20. The apparatus of claim 1 wherein the catheter has a length of between 30 cm and 50 cm.

21. The apparatus of claim 1 further comprising a piece of tubing at least partially covering the deployable member, the tubing suitable for confining gas pockets to enhance ultrasonic imaging around the
5 deployable member.

22. The apparatus of claim 21 further comprising adhesives suitable for affixing the deployable members to the tubing to confine the gas pockets within the tubing.

23. The apparatus of claim 21 wherein a plurality of spaced apart pieces of tubing are spaced along the deployable member.

24. The apparatus of claim 1 wherein the deployable member further comprises a hinging member suitable for rotating the deployable member to a predetermined configuration upon deployment.

25. The apparatus of claim 1 wherein the deployable members comprise a plurality of interwoven wires.

26. A method of facilitating visualization of a patient's prostate/bladder junction, the method comprising:

5 providing apparatus comprising a catheter having proximal and distal ends, a proximal deployment port at the proximal end, a first outlet port at the distal end, a first lumen extending therebetween, a plunger having proximal and distal ends, and at least one deployable member affixed to the distal end of the
10 plunger;

advancing the apparatus through the patient's urethra;

15 distally advancing the deployable member beyond the distal outlet port to deploy the deployable member to a predetermined configuration within the patient's bladder; and

proximally retracting the deployable member such that it engages a proximal portion of the patient's bladder.

27. The method of claim 26 further comprising injecting an echo-contrast agent to facilitate visualization of the patient's prostate/bladder junction.

28. The method of claim 26 further comprising ultrasonically imaging a junction between the patient's bladder and the patient's prostate.

29. The method of claim 26 further comprising performing brachytherapy on the patient's prostate.

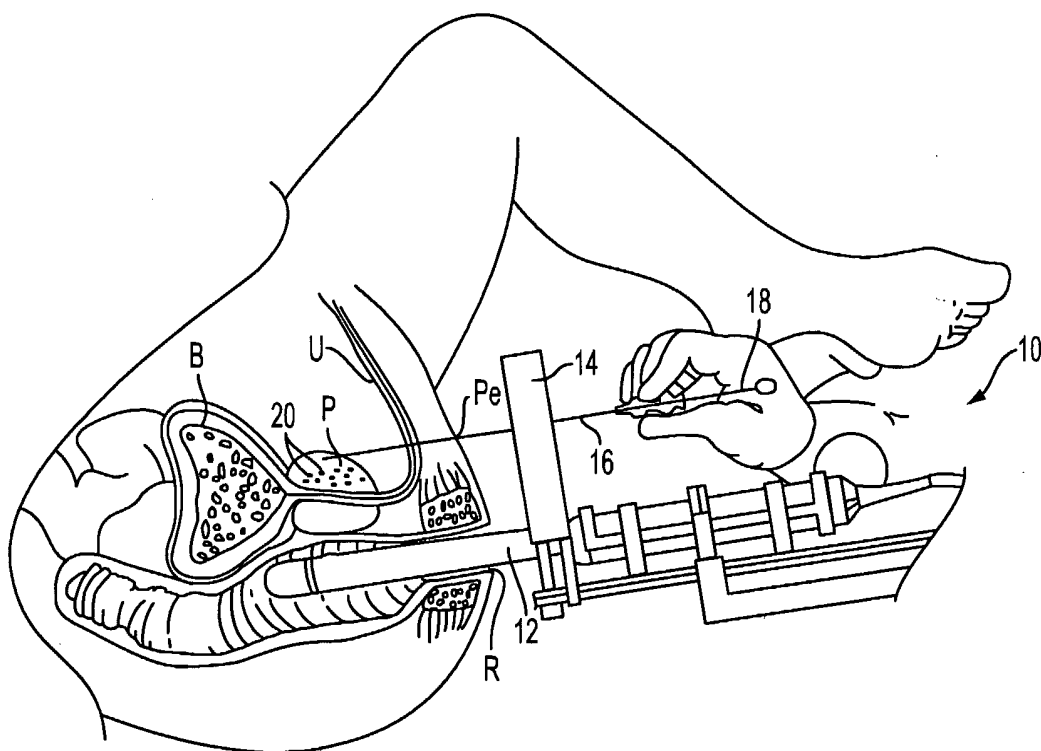

FIG. 1
(PRIOR ART)

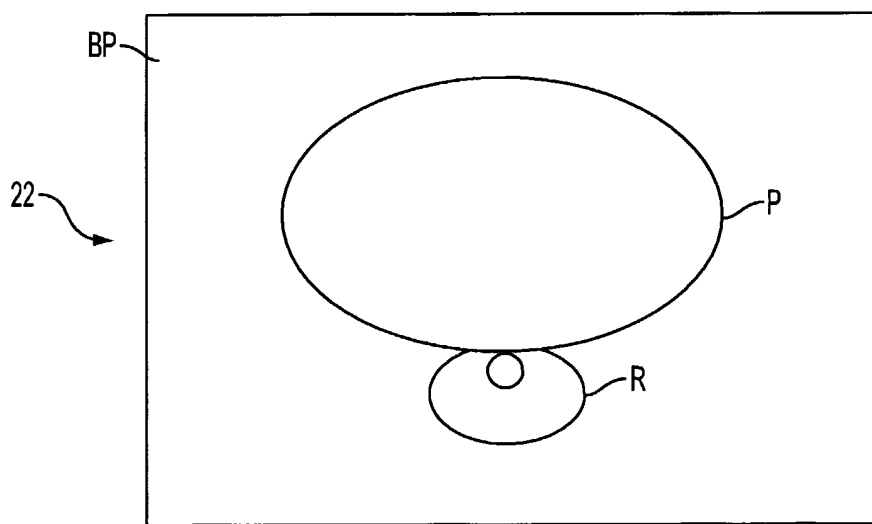

FIG. 2
(PRIOR ART)

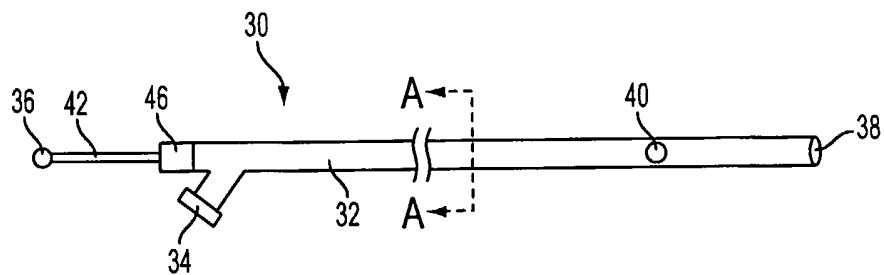

FIG. 3A

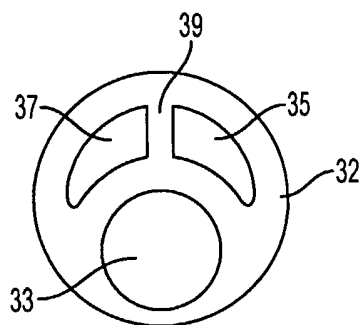

FIG. 3B

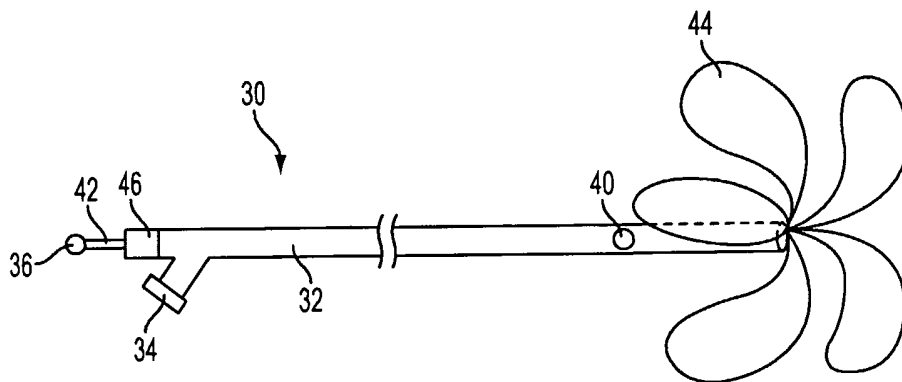

FIG. 3C

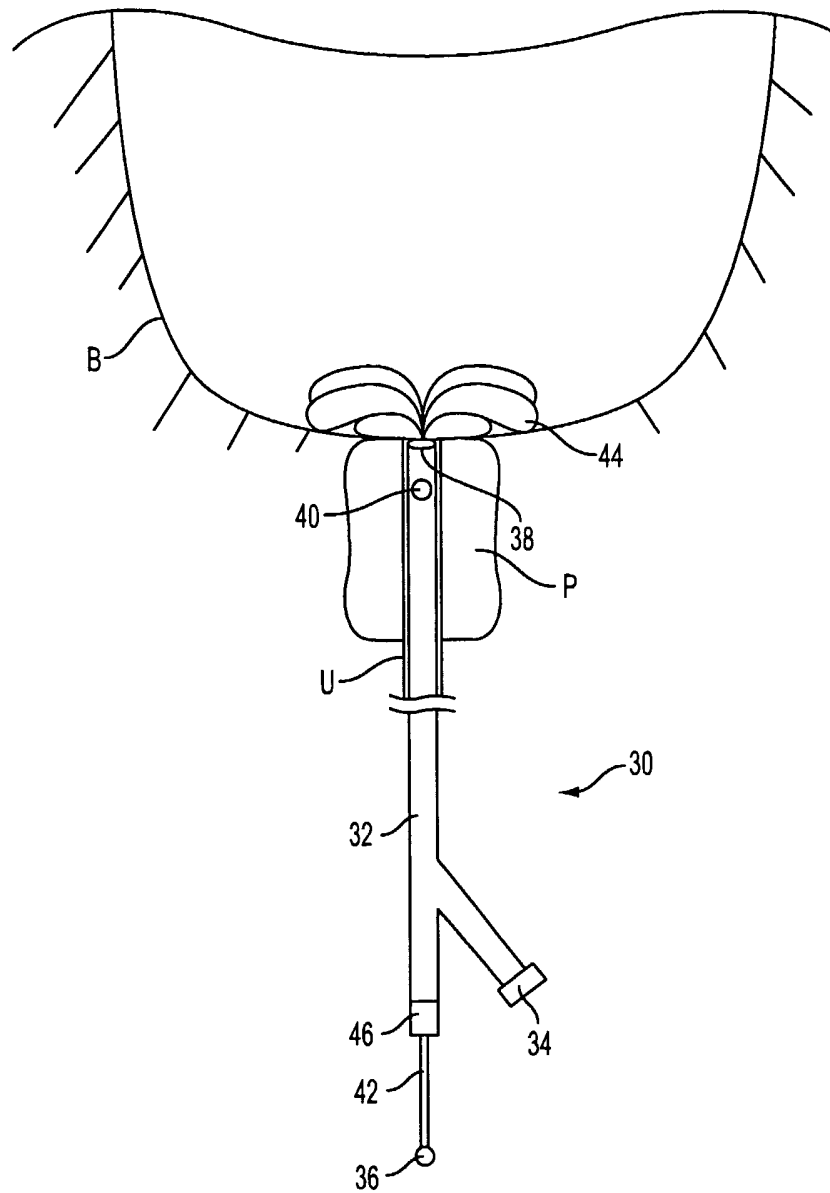

FIG. 4

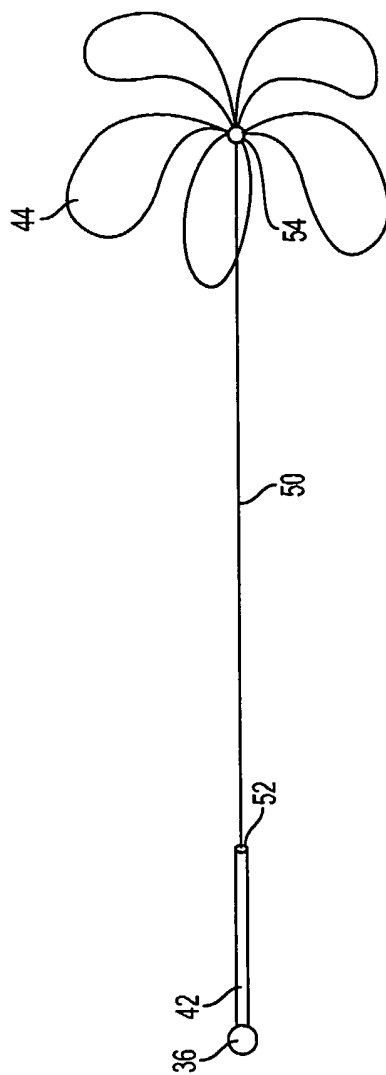

FIG. 5

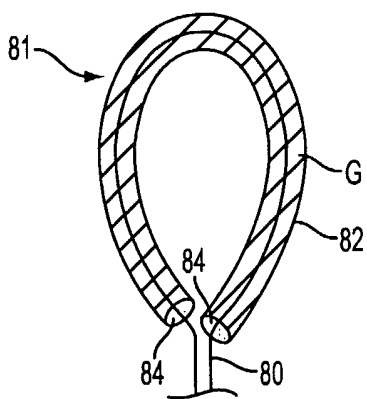

FIG. 6A

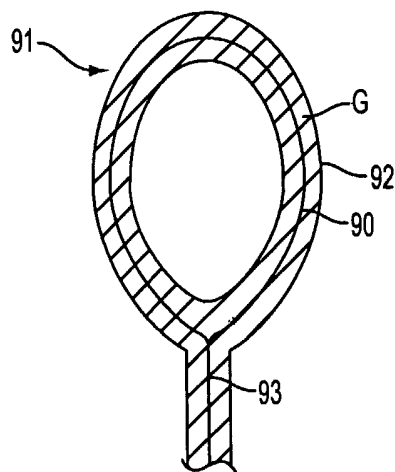

FIG. 6B

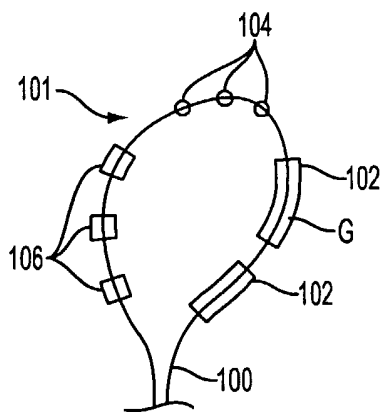

FIG. 6C

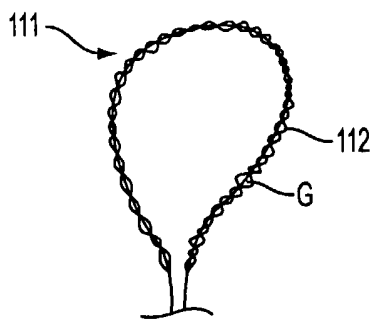

FIG. 6D

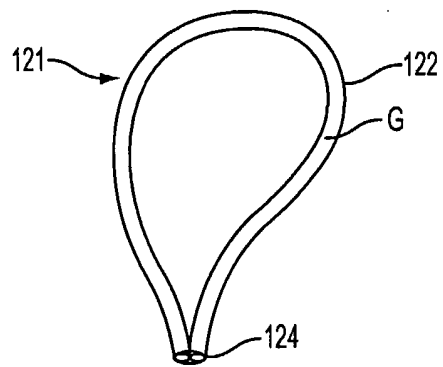

FIG. 6E

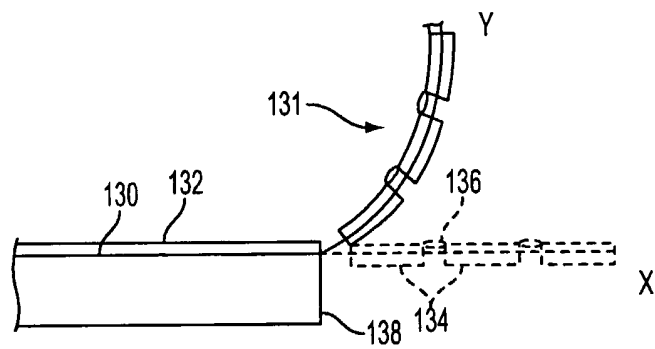

FIG. 7

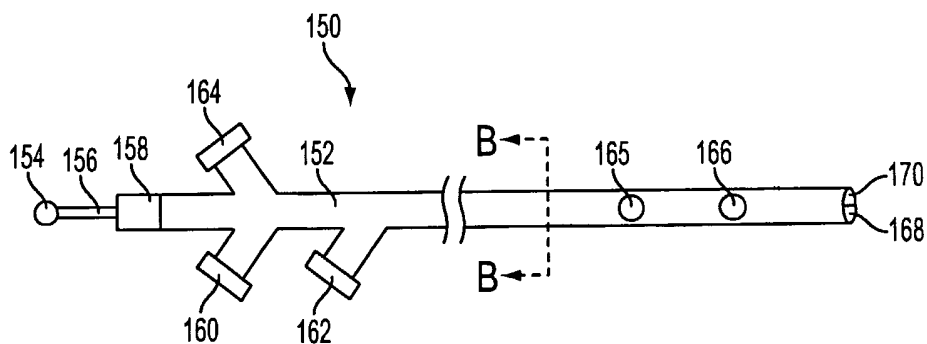

FIG. 8A

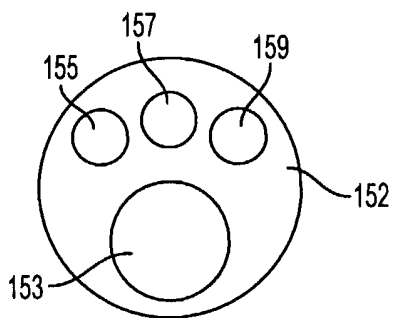

FIG. 8B

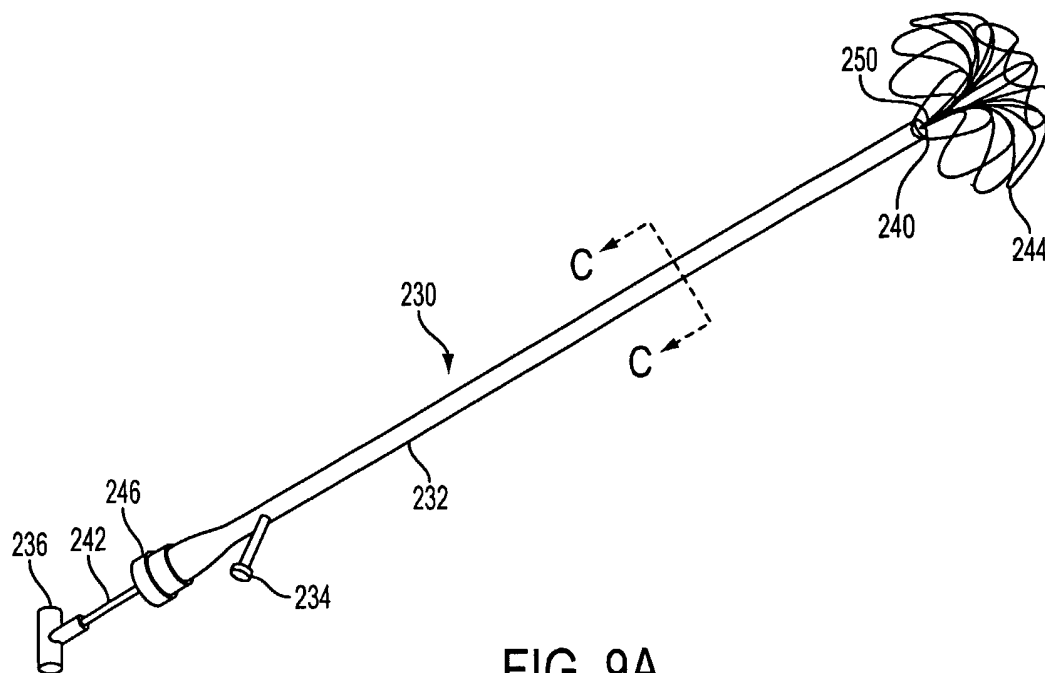

FIG. 9A

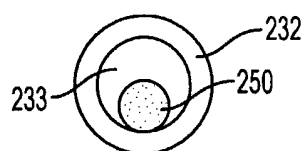

FIG. 9B

INTERNATIONAL SEARCH REPORT

International application No.

PCT/US02/17285

A. CLASSIFICATION OF SUBJECT MATTER

IPC(7) : A61B 1/32
 US CL : 600/207

According to International Patent Classification (IPC) or to both national classification and IPC

B. FIELDS SEARCHED

Minimum documentation searched (classification system followed by classification symbols)
 U.S. : 600/3, 204, 207, 437; 604/101.03, 96, 49, 508, 103.1, 509; 606/108, 48, 15, 192.; 607/99

Documentation searched other than minimum documentation to the extent that such documents are included in the fields searched

Electronic data base consulted during the international search (name of data base and, where practicable, search terms used)

C. DOCUMENTS CONSIDERED TO BE RELEVANT

Category *	Citation of document, with indication, where appropriate, of the relevant passages	Relevant to claim No.
X	US 5,301,688 A (Stephen et al.) 12 April 1994 (12.04.1994), column 9, lines 18-21; Figure 3 (13, 18).	1-3, 8, 10-25
Y, P	US 6,299,598 B1 (Bander) 09 October 2001 (09.10.2001), column 4, lines 1-25, 53-61; column 5, lines 35-36, 58, 59, 63; Figure 1 24, (32-34); Figure 4 (24).	4-7, 9
Y	US 5,899,882 A(Waksman et al.) 04 May 1999 (04.05.1999), abstract; column 3, lines 2-16; column 22, lines 58-62.	26-29

Further documents are listed in the continuation of Box C.

See patent family annex.

* Special categories of cited documents:	"T"
"A" document defining the general state of the art which is not considered to be of particular relevance	later document published after the international filing date or priority date and not in conflict with the application but cited to understand the principle or theory underlying the invention
"E" earlier application or patent published on or after the international filing date	"X" document of particular relevance; the claimed invention cannot be considered novel or cannot be considered to involve an inventive step when the document is taken alone
"L" document which may throw doubts on priority claim(s) or which is cited to establish the publication date of another citation or other special reason (as specified)	"Y" document of particular relevance; the claimed invention cannot be considered to involve an inventive step when the document is combined with one or more other such documents, such combination being obvious to a person skilled in the art
"O" document referring to an oral disclosure, use, exhibition or other means	"&" document member of the same patent family
"P" document published prior to the international filing date but later than the priority date claimed	

Date of the actual completion of the international search

Date of mailing of the international search report

02 August 2002 (02.08.2002)

05 NOV 2002

Name and mailing address of the ISA/US
 Commissioner of Patents and Trademarks
 Box PCT
 Washington, D.C. 20231

Authorized officer

Nikita R Veniaminov *Diana Smee f*
 Telephone No. (703) 308-0858

Facsimile No. (703)305-3230