



(51) International Patent Classification:

F24H 1/22 (2006.01) F24H 1/08 (2006.01)
F02N 19/10 (2010.01) F24H 9/20 (2006.01)
F23N 5/26 (2006.01)

(21) International Application Number:

PCT/CA2017/050391

(22) International Filing Date:

30 March 2017 (30.03.2017)

(25) Filing Language:

English

(26) Publication Language:

English

(30) Priority Data:

62/315,527 30 March 2016 (30.03.2016) US

(71) Applicant: **MARINE CANADA ACQUISITION INC.**
[CA/CA]; 3831 No. 6 Road, Richmond, British Columbia
V6V 1P6 (CA).

(72) Inventors: **STRANG, Kenneth**; 120-3000 Riverbend
Drive, Coquitlam, British Columbia V3C 6R1 (CA). **WIL-
NECHENKO, Bruce**; 5290 Portland Street, Burnaby,
British Columbia V5J 2R2 (CA). **THOMAS, Korbin**;
20429 38 Avenue, Langley, British Columbia V3A 4Y7
(CA).

(74) Agent: **CAMERON IP**; 1401-1166 Alberni Street, Van-
couver, British Columbia V6E 3Z3 (CA).

(81) Designated States (unless otherwise indicated, for every kind of national protection available): AE, AG, AL, AM, AO, AT, AU, AZ, BA, BB, BG, BH, BN, BR, BW, BY, BZ, CA, CH, CL, CN, CO, CR, CU, CZ, DE, DJ, DK, DM, DO, DZ, EC, EE, EG, ES, FI, GB, GD, GE, GH, GM, GT, HN, HR, HU, ID, IL, IN, IR, IS, JP, KE, KG, KH, KN, KP, KR, KW, KZ, LA, LC, LK, LR, LS, LU, LY, MA, MD, ME, MG, MK, MN, MW, MX, MY, MZ, NA, NG, NI, NO, NZ, OM, PA, PE, PG, PH, PL, PT, QA, RO, RS, RU, RW, SA, SC, SD, SE, SG, SK, SL, SM, ST, SV, SY, TH, TJ, TM, TN, TR, TT, TZ, UA, UG, US, UZ, VC, VN, ZA, ZM, ZW.

(84) Designated States (unless otherwise indicated, for every kind of regional protection available): ARIPO (BW, GH, GM, KE, LR, LS, MW, MZ, NA, RW, SD, SL, ST, SZ, TZ, UG, ZM, ZW), Eurasian (AM, AZ, BY, KG, KZ, RU, TJ, TM), European (AL, AT, BE, BG, CH, CY, CZ, DE, DK, EE, ES, FI, FR, GB, GR, HR, HU, IE, IS, IT, LT, LU, LV, MC, MK, MT, NL, NO, PL, PT, RO, RS, SE, SI, SK, SM, TR), OAPI (BF, BJ, CF, CG, CI, CM, GA, GN, GQ, GW, KM, ML, MR, NE, SN, TD, TG).

Published:

— with international search report (Art. 21(3))

(54) Title: VEHICLE HEATER AND CONTROLS THEREFOR

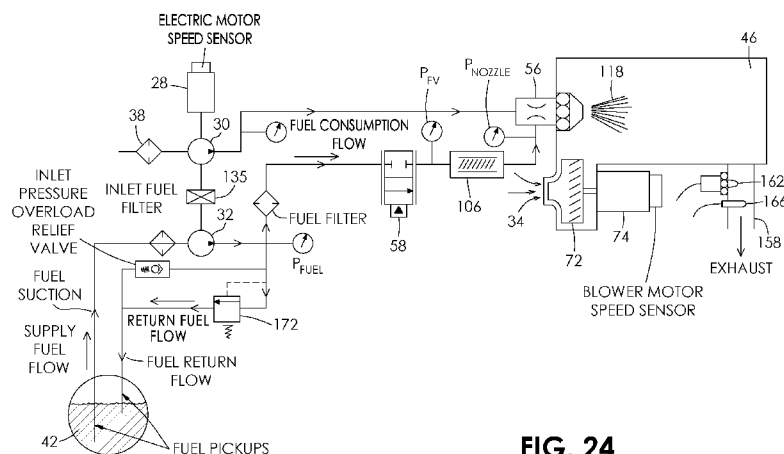

FIG. 24

(57) Abstract: A heater comprises a combustion chamber and a jacket extending about the combustion chamber. There is a fan having an output which communicates with the combustion chamber to provide combustion air. There is also a fuel delivery system having a variable delivery rate. A burner assembly is connected to the combustion chamber. The burner assembly has a burner mounted thereon adjacent the combustion chamber. The burner receives fuel from the fuel delivery system. There is an exhaust system extending from the combustion chamber. An oxygen sensor is positioned in the exhaust system to detect oxygen content of exhaust gases. There is a control system operatively coupled to the oxygen sensor and the fuel delivery system. The control system controls the delivery rate of the fuel delivery system according to the oxygen content of the exhaust gases

WO 2017/165973 A1

VEHICLE HEATER AND CONTROLS THEREFOR

TECHNICAL FIELD

[0001] The present disclosure relates to heaters and, in particular, to heaters for heating
5 the coolant of vehicles and to controls therefor.

BACKGROUND

[0002] Diesel fired coolant heaters are essentially water heaters. They are typically
installed in commercial, industrial and marine applications to preheat engines to facilitate
starting in cold weather or to provide comfort heat to the passenger compartments. They
10 burn liquid fuels to generate heat which is then transferred to the coolant system of the
target application. Coolant is then circulated throughout the system to deliver the heat to
the desired locations and thus transferred to the engine or heat exchangers.

[0003] In cold weather, engines can be difficult to start because the oil becomes more
viscous, causing increased resistance of the internal moving parts, while cold diesel fuel
15 does not atomize and ignite as readily. Cold engines work inefficiently, resulting in
increased wear, decreasing useful engine life. To overcome these issues, heated coolant is
circulated through the engine, heating the engine block, internal components and oil within.

[0004] In cold weather, when vehicles are stationary, the engines are typically idled to
generate heat to keep the engine and passenger compartments warm. Utilization of a
20 coolant heater eliminates the need to idle the engine, thus reducing the overall fuel
consumption, corresponding emissions and provides a reduction in engine maintenance.
Heat generated by the heater is transferred to the engine directly by circulating coolant
through the engine block.

[0005] In some cases, newer commercial engines are very efficient but need to operate within specific operating temperatures to ensure proper operation of the emissions control equipment. In some applications, the engine loading is low and thus it never reaches the required operating temperature. Diesel fired coolant heaters are utilized to add heat to the engine to maintain or increase the operating temperatures so that the emissions control equipment operates correctly.

[0006] In cold temperatures, hydraulic equipment must be cycled gently until it warms up, otherwise it can be damaged. Heated coolant can be provided to heat hydraulic system reservoirs and equipment to enable faster operation in cold temperatures, reducing potential component life damage.

[0007] Heat can also be applied with such heaters to temperature sensitive loads such as cooking grease in rendering trucks or for the transportation of waxes or foodstuffs which may solidify in cold temperatures.

SUMMARY

[0008] It is an object of the present invention to provide an improved vehicle heater and controls therefor.

[0009] There is accordingly provided a heater for a liquid, the heater comprising a combustion chamber and a jacket for the liquid which extends about the combustion chamber. There is a fan having an output which communicates with the combustion chamber to provide combustion air. There is also a fuel delivery system having a variable delivery rate. A burner assembly is connected to the combustion chamber. The burner assembly has a burner mounted thereon adjacent the combustion chamber. The burner receives fuel from the fuel delivery system. There is an exhaust system extending from the combustion chamber. An oxygen sensor is positioned in the exhaust system to detect oxygen content of exhaust gases. There is a control system operatively coupled to the

oxygen sensor and the fuel delivery system. The control system controls the delivery rate of the fuel delivery system according to the oxygen content of the exhaust gases. The oxygen sensor may also detect the presence or absence of a flame by measuring the oxygen content of exhaust gases in the exhaust system.

5 [0010] The control system may provide a closed loop feedback control. The fuel delivery system may include a proportional control valve. The control system may control the delivery rate of the fuel delivery system via the proportional control valve.

[0011] The heater may include an air compressor. The burner may have an atomizing nozzle connected to the compressor to receive compressed air therefrom. The nozzle may
10 be connected to the fuel delivery system to receive fuel therefrom. The nozzle may have a disparager assembly. The disparager assembly may include an outer barrel having a threaded inner wall portion and an inner rod having a threaded outer wall portion. The threaded inner wall portion of the outer barrel and the threaded outer wall portion of the inner rod may have different thread pitches.

15 [0012] The fuel delivery system may have a fuel pump and the air compressor may have an electric drive motor. The electric drive motor may be operatively coupled to the fuel pump by a magnetic coupling to power the fuel pump. The magnetic coupling may include a drive cup rotated by the electric drive motor of the compressor. There may be a shaft follower within the drive cup which is connected to the fuel pump by a shaft.

20 [0013] The combustion chamber may have a wall with a plurality of openings extending therethrough. The openings may communicate with the fan to deliver additional air along the combustion chamber. The wall of the combustion chamber may be a double wall. The double wall may include a cylindrical inner wall portion, a cylindrical outer wall portion which extends about and is spaced-apart from the inner wall portion, and a
25 passageway extending between the inner wall portion and the outer wall portion. The passageway may be operatively connected to the fan to receive combustion air therefrom.

The plurality of openings may extend through the inner wall portion of the combustion chamber.

[0014] The heater may include an air swirler which forces combustion air to swirl prior to entry into the combustion chamber. The air swirler may have radially or axially
5 extending fins.

[0015] There may be a first set of spaced-apart fins extending from the combustion chamber to the jacket to promote heat transfer therebetween. The first set of spaced-apart fins may comprise a plurality of axially and radially extending fins. There may be a second set of spaced-apart fins extending from the combustion chamber to the jacket and from near
10 a first end of the combustion chamber partway towards a second end of the combustion chamber. The second set of spaced-apart fins may also comprise a plurality of axially and radially extending fins. Each of the fins of the second set of spaced-apart fins may be disposed between two adjacent fins of the first set of fins.

[0016] The jacket of the heater may include a first temperature sensor and a second
15 temperature sensor. The control system may detect the presence or absence of a flame by comparing a temperature of the liquid at the first temperature sensor and a temperature of the liquid at the second temperature sensor.

BRIEF DESCRIPTION OF THE DRAWINGS

[0017] Figure 1 is a front, side perspective view of a vehicle heater;

20 [0018] Figure 2 is a rear, side perspective view of the heater of Figure 1;

[0019] Figure 3 is a front, side perspective view of the heater of Figure 1 with an exterior panel removed to show control components thereof;

[0020] Figure 4 is a fragmentary, cross-sectional view of a magnetic coupling for coupling a fuel pump and an air compressor to their common motor;

[0021] Figure 5 is a fragmentary, partially schematic view of a fuel system, ignition system and burner head of the heater of Figure 1;

5 [0022] Figure 6 is a front, perspective view of the heater of Figure 1 with a burner head thereof removed;

[0023] Figure 7 is an exploded view of the heater of Figure 1 with the burner head removed;

[0024] Figure 8 is a front view of a combustion chamber of the heater of Figure 1;

10 [0025] Figure 9 is a cross-sectional view of the combustion chamber taken along line 9-9 of Figure 8;

[0026] Figure 10 is a fragmentary, side cross-sectional view of the combustion chamber of the heater of Figure 1;

[0027] Figure 11 is a fragmentary, front perspective view of a heat exchanger of the
15 heater of Figure 1 showing fins extending from the combustion chamber to a coolant jacket thereof;

[0028] Figure 12 is a front, side perspective view of one set of the fins of Figure 11;

[0029] Figure 13 is a side cross-sectional view of a nozzle of the heater of Figure 1;

[0030] Figure 14 is an exploded view of the air compressor of the heater of Figure 1;

[0031] Figure 15A is a perspective view of a fuel pump of the heater of Figure 1;

[0032] Figure 15B is an exploded view of the fuel pump of the heater of Figure 1;

[0033] Figure 16 is a perspective view of an assembled fan assembly of the heater of Figure 1;

5 [0034] Figure 17 is an exploded view of the fan assembly of Figure 16;

[0035] Figure 18 is a perspective view of the fan assembly showing an air swirler thereof;

[0036] Figure 19 is a side cross-sectional view of the heater of Figure 1 showing the flow of combustion air through the air swirler of Figure 18;

10 [0037] Figure 20 is a simplified, partially schematic view of the heat exchanger of the heater of Figure 1 showing paths of combustion air and exhaust gases;

[0038] Figure 21 is a perspective view of the fan assembly showing another air swirler thereof;

15 [0039] Figure 22 is a side cross-sectional view of the heater of Figure 1 showing the flow of combustion air through the air swirler of Figure 21;

[0040] Figure 23 is an enlarged, fragmentary side view showing a portion of an exhaust conduit of the heater of Figure 1 and an oxygen sensor thereof;

[0041] Figure 24 is a schematic diagram of fuel, exhaust and combustion air components of the heater of Figure 1;

[0042] Figure 25 is a schematic diagram of a closed loop control system of the heater of Figure 1;

[0043] Figure 26 is a graph of a flame detection system of the heater of Figure 1;

[0044] Figure 27 is another graph of the flame detection system of the heater of Figure
5 1;

[0045] Figure 28 is a schematic diagram of a fuel delivery system of the heater of Figure 1;

[0046] Figure 29 is a front, top perspective view of another vehicle heater; and

[0047] Figure 30 is a rear, bottom perspective view of the heater of Figure 29.

10

DESCRIPTION OF EMBODIMENTS

[0048] Referring to the drawings and first to Figures 1 and 2, there is shown a vehicle heater 10. The heater 10 includes a housing 12, a pump which in this example is a coolant pump 14, and a heat exchanger 16. The heat exchanger 16 has a plurality of legs, for example, legs 18 and 20 shown in Figure 2 for mounting the heat exchanger on a support
15 frame 22. The housing 12 includes a controller cover 24 which covers a controller 26 shown in Figure 3. There is also a motor which in this example is an electric motor 28. The electric motor 28 powers an air compressor 30 and a fuel pump 32, both of which are shown in Figure 4. Referring back to Figures 1 and 2, the heater 10 further includes an air intake 34 which receives combustion air for the heater and an exhaust system 36 which discharges
20 exhaust gases from the heater. There is also an air filter 38 shown in Figure 3. The heater 10 further includes a fuel line connector 40 for connecting the heater to a fuel tank 42 of a vehicle via a fuel line 44 as shown in Figure 5.

[0049] As best shown in Figures 6 and 7, the heat exchanger 16 includes a cylindrical combustion chamber 46 and an outer jacket extending about the combustion chamber, which in this example is a coolant jacket 48. The coolant pump 14 circulates a liquid, which in this example is engine coolant, through the heat exchanger 16 in order to heat the coolant.

5 In particular, the coolant is fed through the coolant jacket 48 of the heat exchanger 16 via a conduit 50. The coolant is then heated by combustion of fuel in the combustion chamber 46. The coolant may be a mixture of water and antifreeze.

[0050] Referring back to Figure 5, there is a burner head 54 mounted on an end of the combustion chamber 46. The burner head 54 has a nozzle 56 which in this example is a two fluid siphon-type air atomizing nozzle. Fuel from the tank 42 is drawn into the fuel pump 32 via the fuel line 44. The fuel is then discharged from the fuel pump 32 towards a fuel control valve, which in this example is a proportional control valve 58, via a conduit 60. The fuel is then provided to the nozzle 56 via a conduit 62. The nozzle 56 utilizes compressed air received from the air compressor 30 via a conduit 64 to break up the fuel and deliver a highly atomized spray of fuel into the combustion chamber 46. An igniter 66 ignites the atomized fuel to produce a flame 68. Combustion air for the combustion reaction is supplied to the combustion chamber 46 by a blower assembly 70 which includes a blower 72 and a blower motor 74 for powering the blower. The heat generated by the combustion reaction is transferred to the coolant flowing through the heat exchanger 16 and then circulated throughout the vehicle coolant system.

[0051] As best shown in Figures 8 to 10, the combustion chamber 46 in this example has a double wall formed by a cylindrical inner wall portion 76 and a cylindrical outer wall portion 78. The cylindrical inner wall portion 76 and the cylindrical outer wall portion 78 are spaced apart from each other by an annular space 80 which provides a passageway between the wall portions. A plurality of apertures 82 extends through the inner wall portion 76 and communicates with the space 80. In this example, the apertures 82 are arranged in spaced-apart, annular rows 84 and 86 which extend circumferentially about the inner wall portion 76. The apertures 82 permit air to enter the combustion chamber 46 from the space 80.

[0052] Referring back to Figure 7, there is a first set of fins 88 extending radially inwardly from the coolant jacket 48 to the combustion chamber 46. The fins 88 facilitate the transfer of heat from the combustion chamber 46 to the coolant jacket 48 and thus the coolant flowing through the coolant jacket. In this example, the fins 88 comprise a single, cylindrical member which is annular in profile. The cylindrical member is an aluminum casting in this example but may be of other metals formed in ways other than casting. The fins 88 extend from near a first end 90 of the combustion chamber 46 to a position near a second end 92 of the combustion chamber 46. In this example, each of the fins 88 tapers in profile from the second end 92 of the combustion chamber 46 to the first end 90 thereof. Accordingly, the fins 88 are thinner near the first end 90 of the combustion chamber 46 than near the second end 92 of the combustion chamber 46. The fins 88 are also spaced further apart from adjacent fins near the first end 90 of the combustion chamber 46 than near the second end 92 thereof. This is caused by using a single annular casting for the fins 88 in order to facilitate removal of the casting from a mould. However, the result is that the spacing between the fins 88 is less optimal near the first end 90 of the combustion chamber 46.

[0053] Referring now to Figures 11 and 12, there is a second set of fins 94 which extends from a position near the first end 90 of the combustion chamber 46 part way towards the second end 92 thereof. In this example, the fins 94 also comprise a single, cylindrical member which is annular in profile and of aluminum casting as best shown in Figure 12. However, the fins 94 may also be of other materials and be in other configurations in other examples. Each of the fins 96 is positioned between two adjacent fins of the first set of fins 88 to reduce spacing between the fins of the set of fins 88 and accordingly optimize heat transfer between the combustion chamber 46 and the coolant jacket 48.

[0054] The nozzle 56 is shown in greater detail in Figure 13 and includes a hex body 98, a stem 100, a cap 102 and a distributor 104. The stem 100 has an axial bore 103 through which fuel from the fuel tank 42, shown in Figure 5, flows in the direction indicated by arrow 105. Referring back to Figure 13, there is also a disparager assembly 106 and a seal

in the form of an O-ring 107 which is disposed between the disparager assembly 106 and the distributor 104. The disparager assembly 106 includes an outer barrel 108 and an inner rod 110 which are concentric with each other. The outer barrel 108 has a threaded inner wall portion 112 and the inner rod 110 has a threaded outer wall 114. The threaded inner wall portion 112 of the outer barrel 108 and the threaded outer wall 114 of the inner rod 110 have different thread pitches which creates a torturous flow path for the fuel as it flows through the disparager assembly 106. This disrupts the flow of gas bubbles within the fuel stream, thereby breaking up larger gas bubbles into smaller gas bubbles prior to passing into the distributor 104. The sizes of the gas bubbles are sufficiently reduced after passing through the disparager assembly 106 to avoid disrupting the fuel flow to the combustion chamber 46. Otherwise, the combustion process may be interrupted which may cause the heater 10 to stumble or flame out. Compressed air supplied from the air compressor 30, shown in Figure 5, flows through the nozzle 56 as indicated by arrow 116 in Figure 13 and interacts with the fuel, causing the fuel to break up into an atomized spray 118 consisting of small droplets of fuel. The small droplets of fuel are evaporated by the heat of combustion and form a combustible gas which, when mixed well with air, is burned in the combustion chamber 46 shown in Figure 5. The degree of atomization of the fuel is dependent upon the supplied air pressure from the air compressor 30.

[0055] The air compressor 30 is shown in greater detail in Figure 14 and includes an air compressor housing 120, a diaphragm 122, a cylinder head 124 and an air filter 126. Referring now to Figures 15A and 15B, the fuel pump 32 is shown in greater detail. The fuel pump 32 is a gerotor pump in this example but may be a different type of pump such as a gear pump in other examples. The fuel pump 32 is mounted on a fuel pump housing 128 together with the proportional control valve 58. The fuel pump 32 has a connecting rod assembly 130, shown in Figure 14, which is connected to the electric motor 28.

[0056] As shown in Figure 4, the electric motor 28 has an output shaft 132 which drives both the air compressor 30 and the fuel pump 32. In this example, the electric motor 28 drives the air compressor 30 and the fuel pump 32 simultaneously at the same speed. The output shaft 132 is provided with a moulded drive cup 134 which forms part of a magnetic

coupling 135 with a cylindrical, moulded shaft follower 136 received within the drive cup 134. The drive cup 134 has internal magnets 138 in an annular wall thereof and the shaft follower 136 has magnets 140 in an annular wall thereof. A shaft 142 of the shaft follower 136 is connected to the fuel pump 32. When the output shaft 132 of the electric motor 28 rotates, the drive cup 134 rotates the shaft follower 136 which cause its shaft 142 to rotate the fuel pump 32. There is also a moulded separator cup 137 located between the electric motor 28 and the fuel pump 32. The separator cup 137 contains the fuel within the fuel pump 32 while magnetically transferring the rotational torque to drive the fuel pump. This eliminates the need for a dynamic shaft seal on the fuel pump which reduces the potential for fuel leaks. The output pressure of the fuel pump 32 remains constant throughout the RPM range of the pump.

[0057] Figures 16 and 17 shows a fan assembly 144 which provides combustion air for the heater 10. The fan assembly 144 includes a fan housing 146 which receives the blower assembly 70 including the blower 72 and the blower motor 74. The fan assembly 144 further includes a cylindrical sleeve 148 and an air swirler 150 which is mounted on the cylindrical sleeve as best shown in Figure 18. The sleeve 148 is adapted to receive the nozzle 56. The air swirler 150 has fins which extend radially outwardly from the sleeve 148. The air swirler 150 is located in the path of the combustion air supply indicated by arrow 152 and forces the combustion air to swirl prior to entry into the combustion chamber 46 as shown in Figure 19. The swirling air 155 interacts with the atomized fuel spray 118, shown in Figure 20, causing the air and the fuel to mix. The swirling air also creates a vortex which creates a recirculation in the combustion chamber 46, causing the hot gases of combustion to interact with the new air/fuel mixture delivery. The internal recirculation zone created by the swirling air results in low velocity regions which anchor the flame. This improves mixing and flame stabilization which results in a shorter, more compact flame and lower nitric oxides.

[0058] As shown in Figure 20, there are three air passages for the delivery of combustion air to the combustion chamber 46. The majority of the combustion air (approximately 70%) is delivered through the air swirler 150 as indicated by arrows 152.

Approximately 10% of the combustion air is atomized air supplied from the air compressor 30 which flows through the atomizing nozzle 56 as indicated by arrow 154 to break up the fuel into droplets. The balance of the combustion air (approximately 20%) is routed through the annular space 80 between the double wall of the combustion chamber 46 and delivered downstream in the combustion chamber as indicated by arrows 156. This secondary air supply supplements the primary swirled air supply in conjunction with the baffle at the end of the combustion chamber 46 to further enhance the recirculation within the combustion chamber. The baffle and the plurality of apertures 82 in the inner wall portion 76 promote recirculation of combustion gases with the new air/fuel mixture, resulting in improved combustion.

[0059] Figure 21 shows another air swirler 151 which may be used in the fan assembly 144. The air swirler 151 is not mounted on the cylindrical sleeve 148. Instead, the air swirler 151 is located near a base 149 of the sleeve 148. The air swirler 151 has fins which extend upwardly from the base 149 of the sleeve 148. The air swirler 151 is similarly located in the path of the combustion air supply indicated by arrow 152 and forces the combustion air to swirl as indicated by arrow 157 prior to entry into the combustion chamber 46 as shown in Figure 22.

[0060] Referring back to Figure 2, the exhaust system 36 includes an exhaust conduit 158 which is connected to the heater exchanger 16 by a flange 160 which is shown in Figure 7. Typically, the exhaust conduit 158 is connected to the exhaust of the vehicle via an exhaust pipe. There is an oxygen sensor 162 connected to the exhaust conduit 158 as best shown in Figure 2. The oxygen sensor 162 is also operatively connected to the controller 26 which is shown in Figure 3. The oxygen sensor 162 measures the oxygen content of exhaust gases from the heater 10, thereby providing an indication of the air/fuel ratio and the status of the combustion process. Figure 23 shows the oxygen sensor 162 and the exhaust conduit 158 in greater detail.

[0061] Figure 24 shows the fuel control system for the heater 10. The fuel control system is a closed loop fuel control system based on feedback from the oxygen sensor 162.

As shown in Figure 25, feedback 164 from the oxygen sensor 162 to the controller 26 is used to control the fuel control valve, which in this example is the proportional control valve 58. In this way, the fuel delivery rate to the heater is modulated in response to the control loop. The proportional control valve 58, together with the fuel pump 32, provides continuously variable heat output. This is in contrast to conventional stepped control for heat output. Variable heat output control allows power consumption to be optimized.

[0062] The closed loop fuel control system allows the heat output from the heater 10 to be reduced or turned down while maintaining a preset stoichiometry throughout the turndown range. To reduce the heat output, the controller 26 reduces the speed of the blower motor 74 which results in a corresponding reduction in the oxygen level in the exhaust stream. To maintain the preset stoichiometry, the controller 26 then adjusts the proportional control valve 58 to reduce the fuel rate. Reducing the fuel rate in turn causes the oxygen level in the exhaust stream to increase until the target oxygen level set point is reached. The closed loop fuel control system also automatically maintains stoichiometry in situations where the air intake 34 or the exhaust conduit 158 are restricted.

[0063] A speed sensor is integrated into the electric motor 28 common to the air compressor 30 and the fuel pump 32. The blower motor 42 is also provided with a speed sensor. The electric motor 28 and the blower motor 74 are designed to operate specific speeds associated with specific heater output levels. As the heater output is reduced in accordance with the closed loop fuel control strategy or a lower desired output is required, the motor speeds are adjusted accordingly based on the defined lookup table set out below.

Heat Output Setting	10%	20%	30%	40%	50%	60%	70%	80%	90%	100%
Blower Speed (rpm)	1200	1667	2133	2600	3067	3533	4000	4467	4933	5400
Compressor Speed (rpm)	1500	1589	1678	1767	1856	1944	2033	2122	2211	2300

[0064] The heater 10 is designed to operate on voltages of 10 to 30 volts where the motors are nominally rated at 10 volts. As the heater 10 supply voltage fluctuates throughout the supply nominal operating range, a closed loop speed control adjusts the motor speed to follow the required speeds defined in the above lookup table and the desired heater output setting.

[0065] The closed loop fuel control system further maintains combustion stoichiometry and resulting exhaust emissions as the operating altitude of the heater increases. As altitude increases, the air density decreases and the performance of the blower 72 and the air compressor 30 are reduced proportionally. If the fuel rate is not adjusted as the altitude increases, and resultant air flow decreases, the oxygen level in the exhaust gases will decrease and the carbon monoxide content in the exhaust gases will increase. To compensate for the reduced air density, the controller 26 reduces the fuel rate proportionally to maintain the specified stoichiometry or preset oxygen level target.

[0066] The heat output of the heater 10 is also automatically adjusted to match the ability of the vehicle coolant system to accept the generated heat. The amount of generated heat that can be transferred to the coolant is proportional to the flow rate of the coolant. If the coolant flow rate is too low, then the coolant cannot absorb all of the heat generated and the temperature rises quickly to the heater cycle off temperature and the heater cycles off. The coolant continues to circulate and because the heating cycle is very short, the coolant is only heated locally within the heat exchanger. The balance of the unheated coolant continues to circulate through the system, resulting in the unheated coolant flowing into the heater. The system temperature sensor measures the low coolant temperature and signals the heater to restart and another heating cycle begins. This frequent start/stop cycle is called short cycling. In this situation, the load never gets warm.

[0067] To prevent short cycling, the closed loop fuel control system utilizes its turndown capability to vary the heater output. As shown in Figures 6 and 7, the heater 10 is provided with temperature sensors 168 and 170. When the temperature sensors 168 and 170 signal a call for heat, the heater 10 initiates a heating cycle. If the heater output is less

than the heating load, the heater will run continuously or until it is shut off as it will never reach the cycle off temperature. If the heating load is less than the heater output, the heater will operate at 100% output until it reaches the cycle off temperature. The control strategy dictates that the heater must run for a minimum of ten minutes after the cycle is initiated.

5 If the elapsed cycle time is less than ten minutes, the heater will start to reduce the heat output. A PID control loop will modulate the heater output using the closed loop fuel control to maintain the coolant temperature at the cycle off temperature for the balance of the ten-minute cycle interval. At the end of the ten minutes, the heater will cycle off.

[0068] The objective of this strategy is to prevent short cycling to ensure that the
10 maximum amount of heat can be transferred to the load. This also ensures that the heater is operated for a period of time that is sufficient to heat up the burner components and burn off fuel and combustion residue, minimizing carbon deposits inside the combustion chamber.

[0069] The heater output can be coupled to a feedback system based on an external
15 heat exchanger to maintain a specific temperature within the heated space. Based on information supplied from the load, the heater can automatically adjust itself to maintain a desired temperature change in the system. Large temperature variations in heating systems can be considered uncomfortable. The more consistent and steady the heat, the more comfortable it can be.

20 [0070] The oxygen sensor 162 has a secondary function as a flame detection device. In particular, the oxygen sensor 162 measures the oxygen level in the exhaust stream to determine if a flame is present in the combustion chamber 46. As shown in Figure 26 during start-up and operation of the heater 10, the level of oxygen in the exhaust stream as measured by the oxygen sensor 162 must reach prescribed limits and be maintained within
25 the prescribed limits to indicate that a suitable flame is present in the combustion chamber 46. If a suitable or “good” flame is detected, the heater 10 will continue to operate. If a good flame is not detected, then the controller 26 will shut down the heater 10.

[0071] However, there are situations in which the oxygen sensor 162 may indicate that a flame is present in the combustion chamber 46 when there is no flame. For example, if the flame does not immediately ignite during ignition, fuel will continue to spray into the combustion chamber and saturate the oxygen sensor 162 with unburned fuel. This may
5 cause the oxygen sensor 162 to potentially indicate a flame where none is present.

[0072] To overcome this problem, secondary heater performance parameters, for example, exhaust gas temperature and coolant outlet temperature, are resolved into a parameter called the EGDT which is monitored concurrently with the oxygen sensor 162 data. The exhaust gas temperature may be measured by a temperature sensor 166 shown in
10 Figure 24. Referring now to Figure 27, if a flame is present in the combustion chamber 46 during ignition or operation of the heater 10, the EGDT parameter is expected to rise or remain above prescribed levels. If a good flame is established at the start of combustion, the oxygen level will decrease while the EGDT value will increase. In cases where the oxygen sensor 162 is being deceived as to the presence of a flame, the oxygen level may
15 decrease as normal but the EGDT will not increase, indicating a failure in flame detection and causing the controller 26 to indicate a fault. The concurrent monitoring of the EGDT parameter provides a secondary validation of the oxygen level reading in the exhaust stream confirming that a flame is present in the combustion chamber 46.

[0073] The heater 10 may also be provided with a backup flame detection system in
20 the form of coolant temperature sensors 168 and 170 which are mounted on the coolant jacket 48 in spaced-apart locations as shown in Figures 6 and 7. The temperature sensors 168 and 170 measure the temperature of the coolant at two separate locations and compares the difference in temperature to a model of the theoretical temperature difference. If the measured temperature difference is outside of the range, then this may signal the lack of a
25 flame. For example, the temperature sensor 168 may measure the temperature of inlet coolant while the temperature sensor 170 may measure the temperature of outlet coolant. The controller 26 senses a rise in the temperature difference between the inlet temperature sensor 168 and the outlet temperature sensor 170 and compares it to a running average of the temperature differences. The system compares the difference between the inlet and

outlet coolant temperatures and the running average of the temperature differences. Depending upon the sign (+/-) of the comparison, the system can detect if a flame of the heater just came on or if it went out.

[0074] Referring now to Figure 28, the fuel delivery system of the heater 10 is shown. A pressure relief valve 172 is used to establish the fuel system operating pressure. At maximum heater output, approximately 85% to 90% of the total fuel flow returns to the fuel tank 42 over the relief valve 172. The balance of the total fuel flow (approximately 10% to 15%) is ported through the proportional control valve 58 and consumed in the combustion chamber 46 to generate heat. As the system operates, fuel delivered from the fuel pump 32 passes into a separation chamber 176. This allows large gas bubbles 178 entrained or suspended in the fuel to float up to the top of the chamber 176. There is a narrow fuel passage 180 near the top of the chamber 176. The narrow size of the fuel passage 180 increases the velocity of the fuel through the passage 180. The gas bubbles 178 are carried away in the passage 180 through the relief valve 172 to the fuel tank 42 in the return line 181.

[0075] There is also a narrow passage 182 located at the base of the chamber 176 which leads to a secondary chamber 184. Larger gas bubbles such as the gas bubbles 178 are restricted from entering the secondary chamber 184 due to the narrow size of the passage 182. Fuel flowing into the secondary chamber 184 is at the fuel burn rate which is significantly lower than the total fuel rate through the system. The velocity of the fuel is further reduced as it enters the secondary chamber 184. This lowered velocity increases the residence time of the fuel in the secondary chamber 184, allowing any remaining gas bubbles 186 to float up into the passage 180 and be returned to the fuel tank 42 in the return line 181. Fuel leaving the secondary chamber 184 is metered through the proportional control valve 58 to the atomizing nozzle 56.

[0076] Figures 29 and 30 show another vehicle heater 210. Like parts have like numbers and functions as the vehicle heater 10 described above and shown in Figures 1 to 28 with the addition of “200”.

[0077] It will be understood by a person skilled in the art that many of the details provided above are by way of example only, and are not intended to limit the scope of the invention which is to be determined with reference to the following claims.

What is claimed is:

1. A heater for a liquid, the heater comprising:

a combustion chamber;

a jacket for the liquid, the jacket extending about the combustion chamber;

a fan having an output communicating with the combustion chamber to provide combustion air;

a fuel delivery system having a variable delivery rate;

a burner assembly connected to the combustion chamber, the burner assembly having a burner mounted thereon adjacent the combustion chamber, the burner receiving fuel from the fuel delivery system;

an exhaust system extending from the combustion chamber;

an oxygen sensor positioned in the exhaust system to detect oxygen content of exhaust gases; and

a control system operatively coupled to the oxygen sensor and the fuel delivery system, the control system controlling the delivery rate of the fuel delivery system according to the oxygen content of the exhaust gases.
2. The heater as claimed in claim 1, wherein the control system provides a closed loop feedback control.

3. The heater as claimed in claim 1, wherein the fuel delivery system includes a proportional control valve, the control system controlling the delivery rate of the fuel delivery system via the proportional control valve.
4. The heater as claimed in claim 1, further including an air compressor, the burner having an atomizing nozzle connected to the compressor to receive compressed air therefrom and the nozzle being connected to the fuel delivery system to receive fuel therefrom.
5. The heater as claimed in claim 1, wherein the combustion chamber has a wall with a plurality of openings extending therethrough and communicating with the fan to deliver additional air along the combustion chamber.
6. The heater as claimed in claim 5, wherein the wall of the combustion chamber is a double wall, the double wall including a cylindrical inner wall portion, a cylindrical outer wall portion which extends about and is spaced-apart from the inner wall portion, and a passageway extending between the inner wall portion and the outer wall portion, the passageway being operatively connected to the fan to receive combustion air therefrom, the plurality of openings extending through the inner wall portion.
7. The heater as claimed in claim 1, further including an air swirler which forces combustion air to swirl prior to entry into the combustion chamber.
8. The heater as claimed in claim 7, wherein the air swirler has radially extending fins.
9. The heater as claimed in claim 7, wherein the air swirler has axially extending fins.

10. The heater as claimed in claim 1, wherein the combustion chamber has a first end and a second end, the heater further including:

a first set of spaced-apart fins extending from the combustion chamber to the jacket to promote heat transfer therebetween, the first set of spaced-apart fins comprising a plurality of axially and radially extending fins; and

a second set of spaced-apart fins extending from the combustion chamber to the jacket and from near the first end of the combustion chamber partway towards the second end of the combustion chamber, the second set of spaced-apart fins comprising a plurality of axially and radially extending fins, each of the fins of the second set of spaced-apart fins being disposed between two adjacent fins of the first set of fins.

11. The heater as claimed in claim 1, wherein the jacket includes a first temperature sensor and a second temperature sensor, the control system detecting the presence or absence of a flame by comparing a temperature of the liquid at the first temperature sensor and a temperature of the liquid at the second temperature sensor.

12. A heater for a liquid, the heater comprising:

a combustion chamber;

a jacket for the liquid, the jacket extending about the combustion chamber;

a fan having an output communicating with the combustion chamber to provide combustion air;

a fuel delivery system including a fuel pump;

a burner assembly connected to the combustion chamber, the burner assembly having a burner mounted thereon adjacent the combustion chamber, the burner receiving fuel from the fuel delivery system; and

an air compressor, the air compressor having an output communicating with the burner to supply compressed air thereto;

wherein the burner includes a nozzle having a disarager assembly, the disarager assembly including an outer barrel having a threaded inner wall portion and an inner rod having a threaded outer wall portion, the threaded inner wall portion and the threaded outer wall portion having different thread pitches.

13. The heater as claimed in claim 12, wherein the compressor has an electric drive motor, the electric drive motor being operatively coupled to the fuel pump by a magnetic coupling to power the fuel pump.
14. The heater as claimed in claim 13, wherein the magnetic coupling includes a drive cup rotated by the electric drive motor of the compressor and a shaft follower within the drive cup which is connected to the fuel pump by a shaft.
15. The heater as claimed in claim 12, further including an exhaust system and an oxygen sensor positioned in the exhaust system, the oxygen sensor detecting the presence or absence of a flame by measuring oxygen content of exhaust gases in the exhaust system.

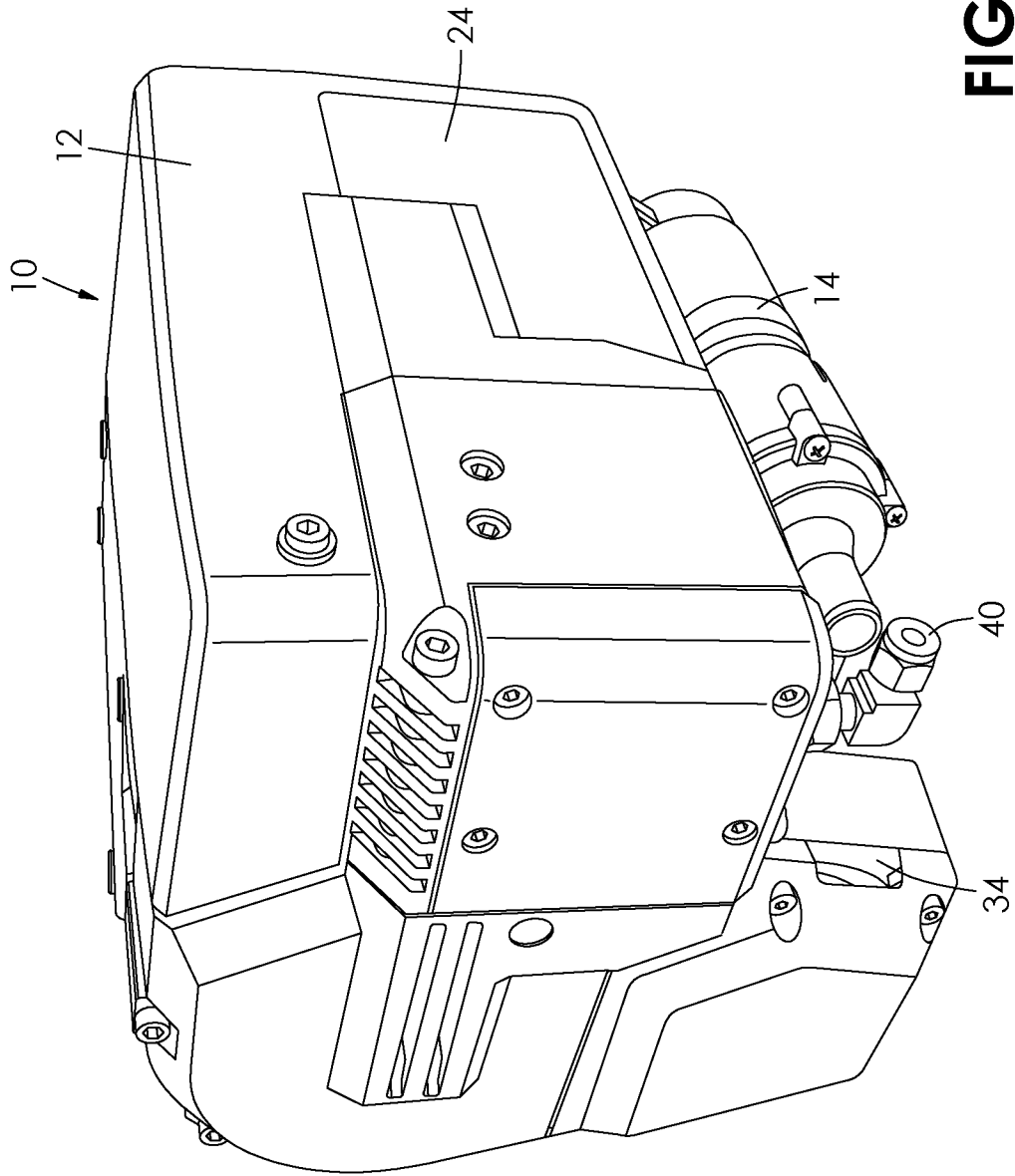

FIG. 1

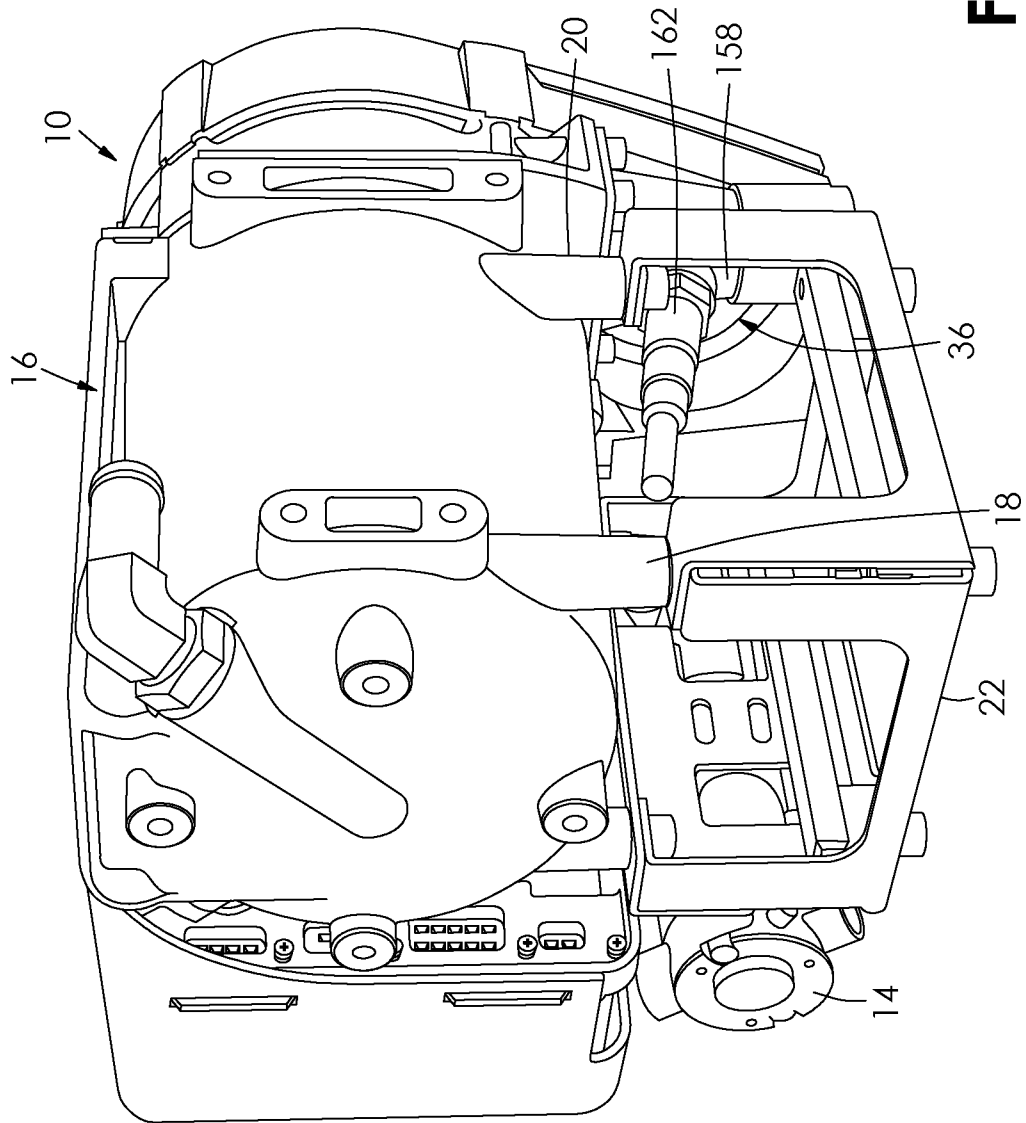

FIG. 2

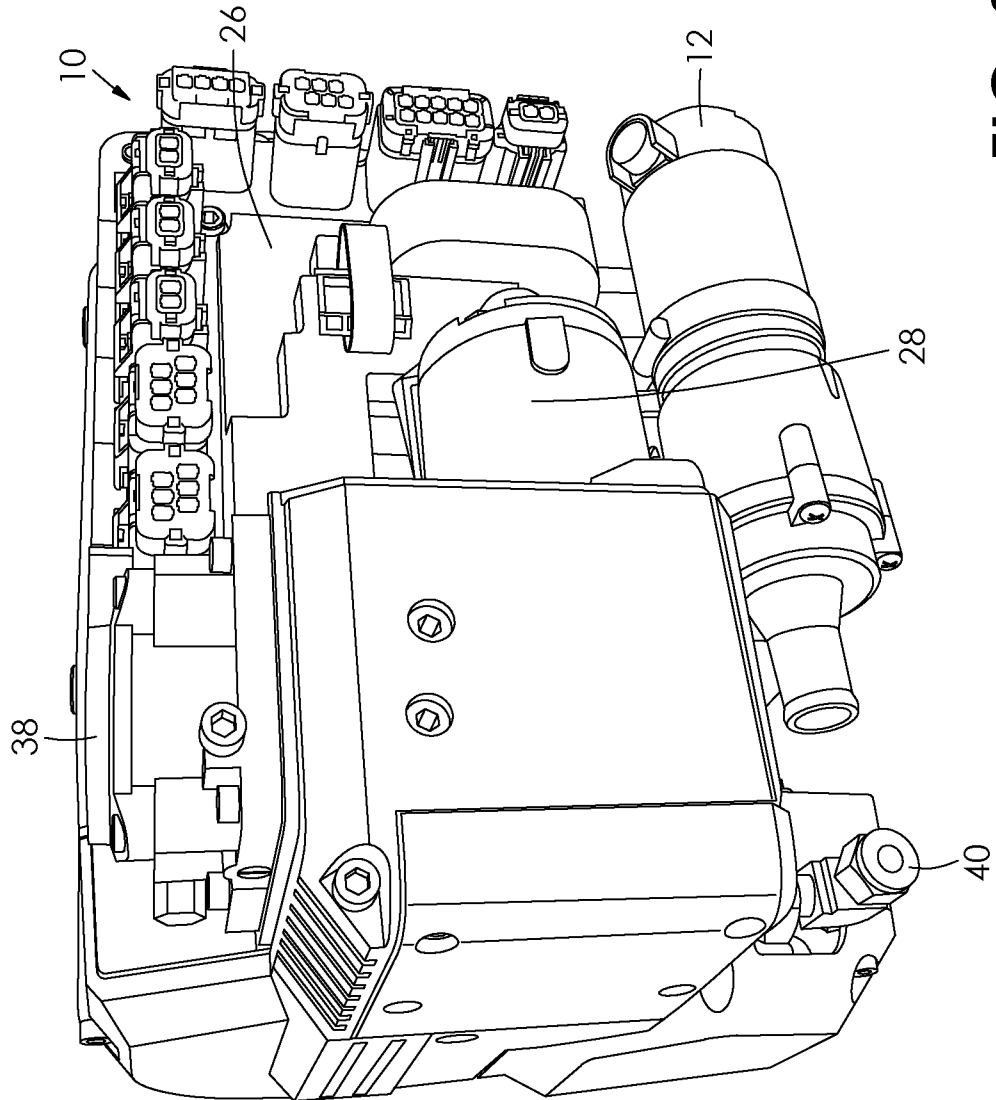

FIG. 3

4/27

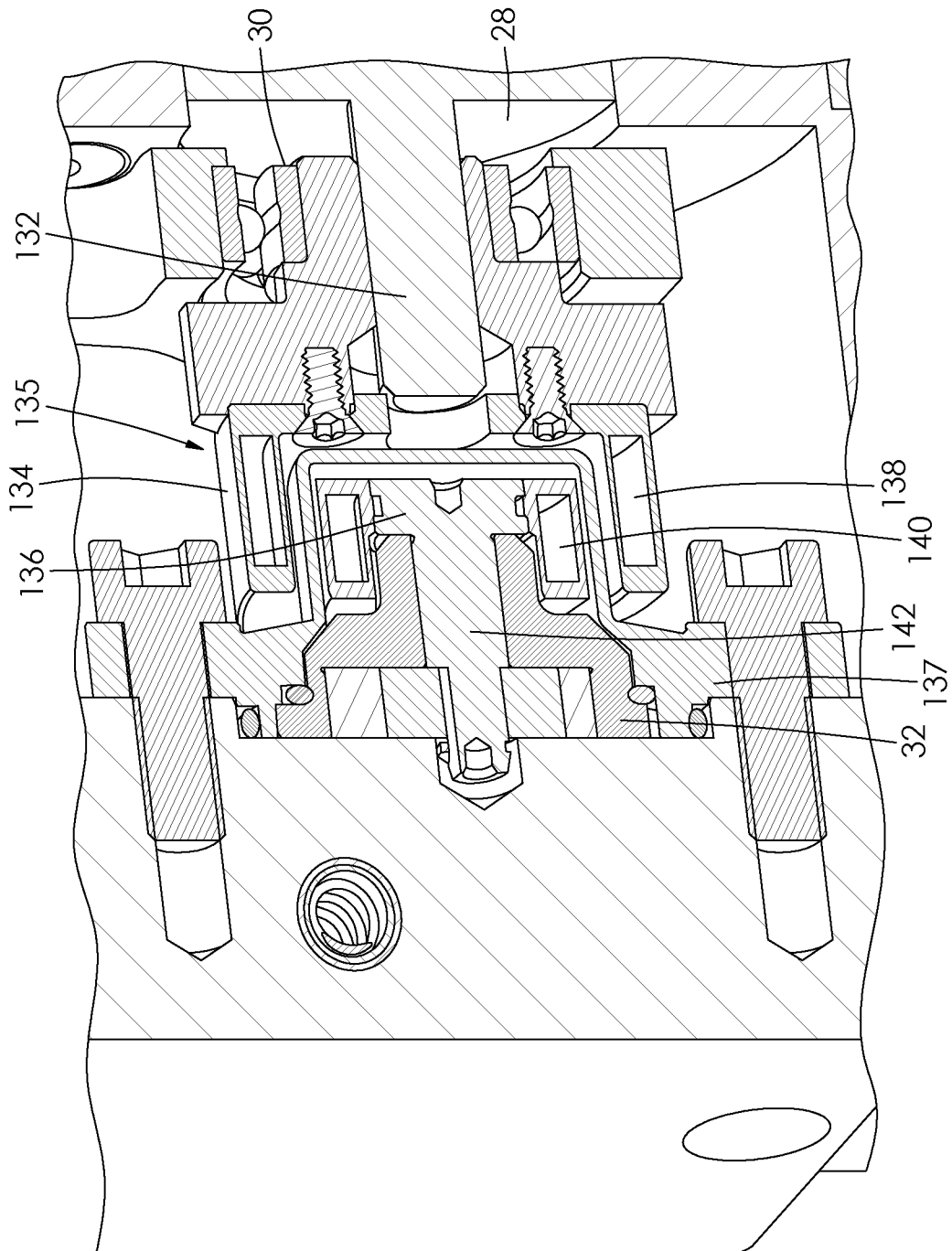

FIG. 4

5/27

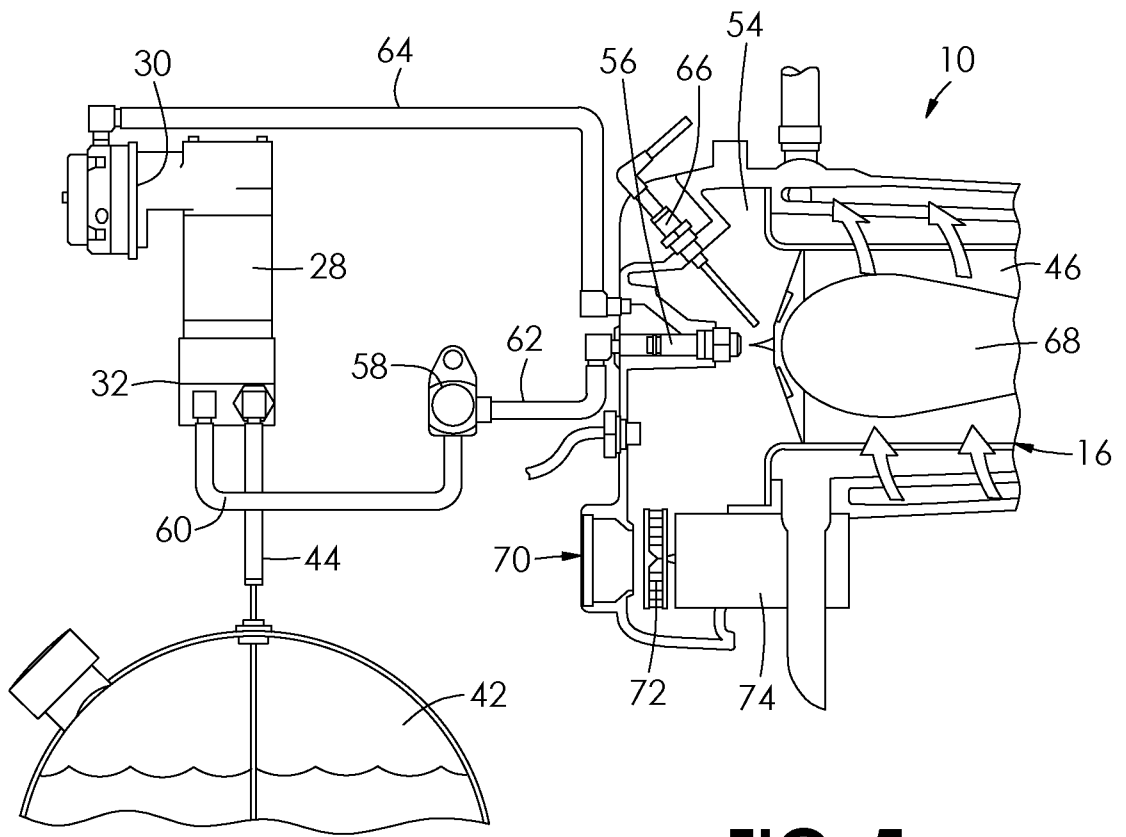

FIG. 5

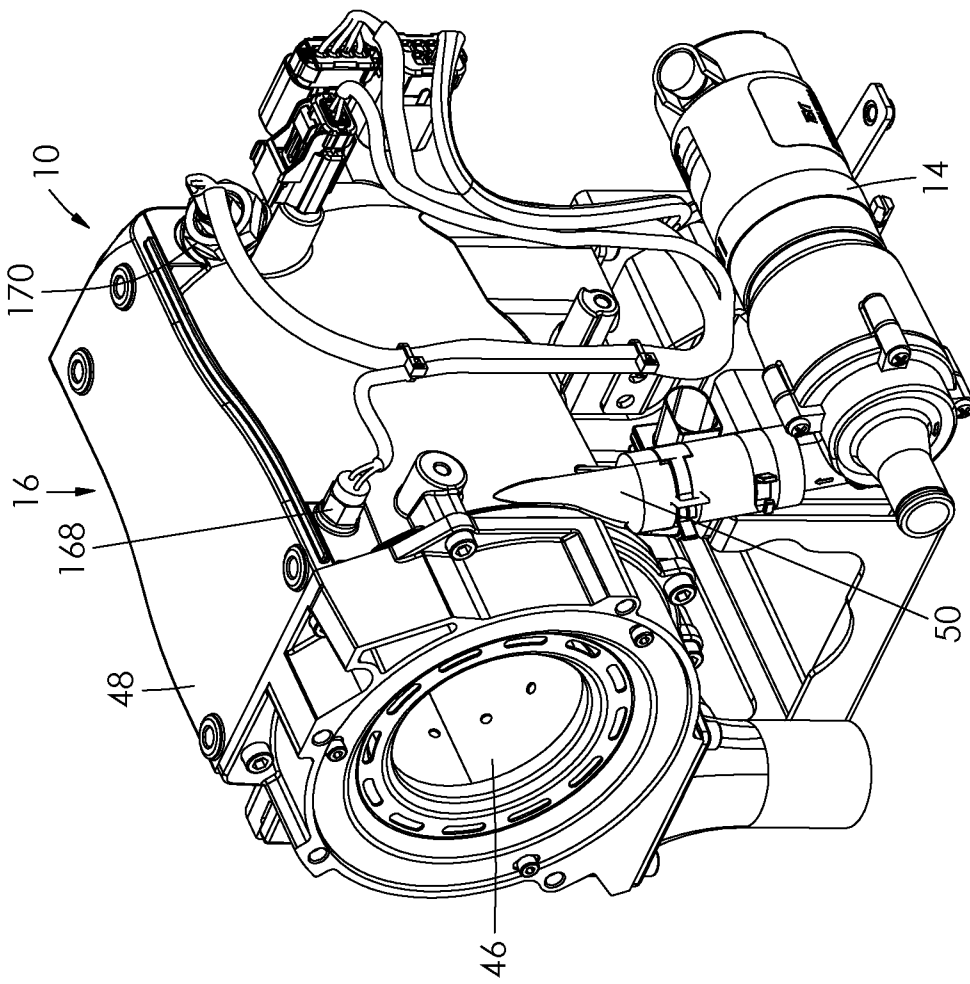

FIG. 6

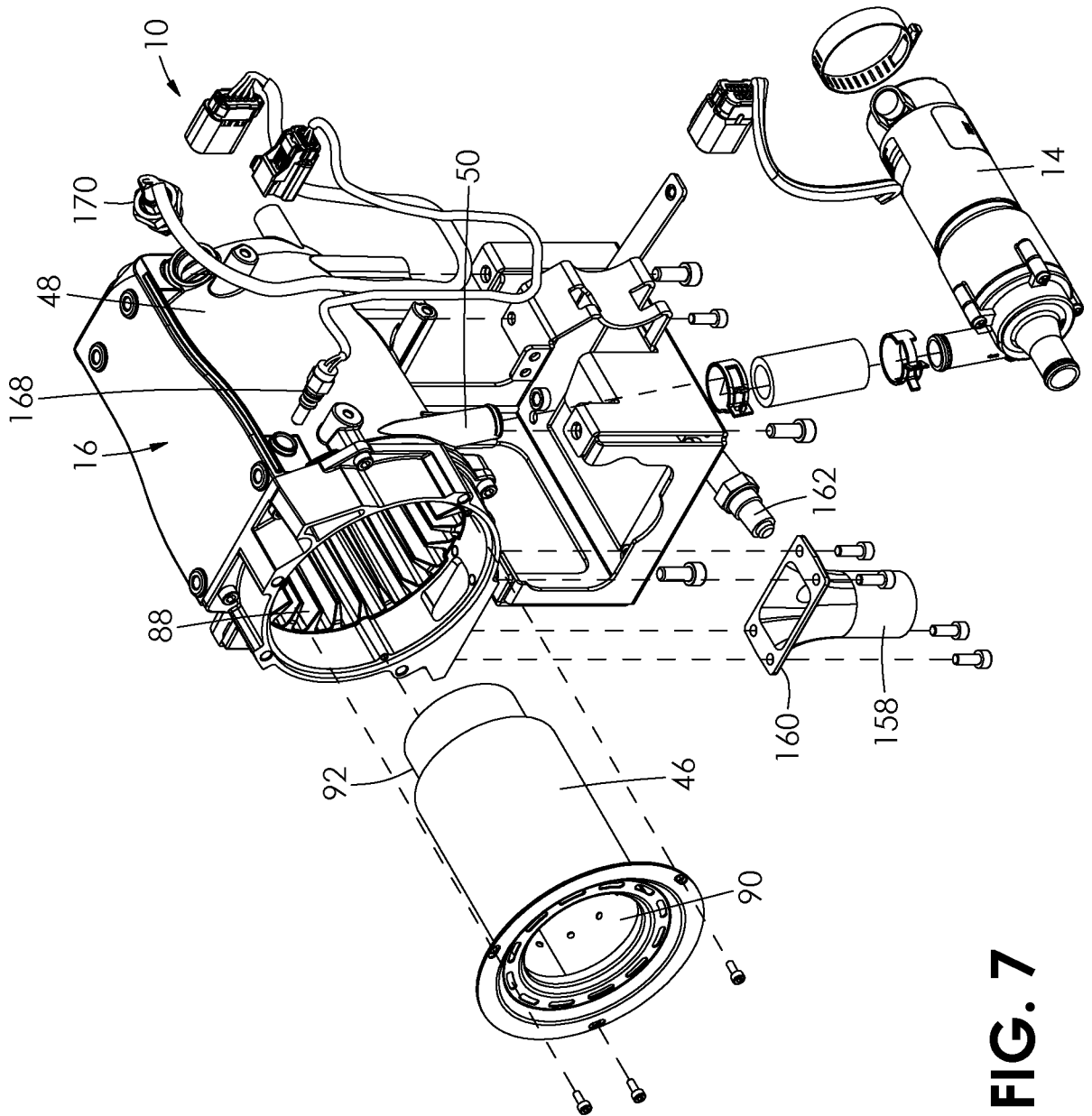

FIG. 7

8/27

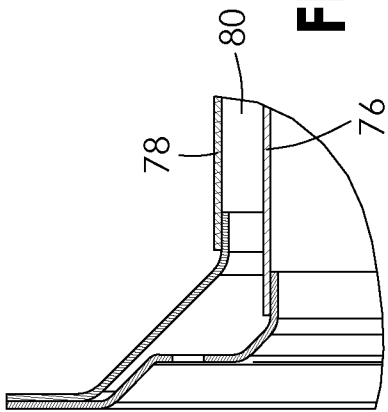

FIG. 10

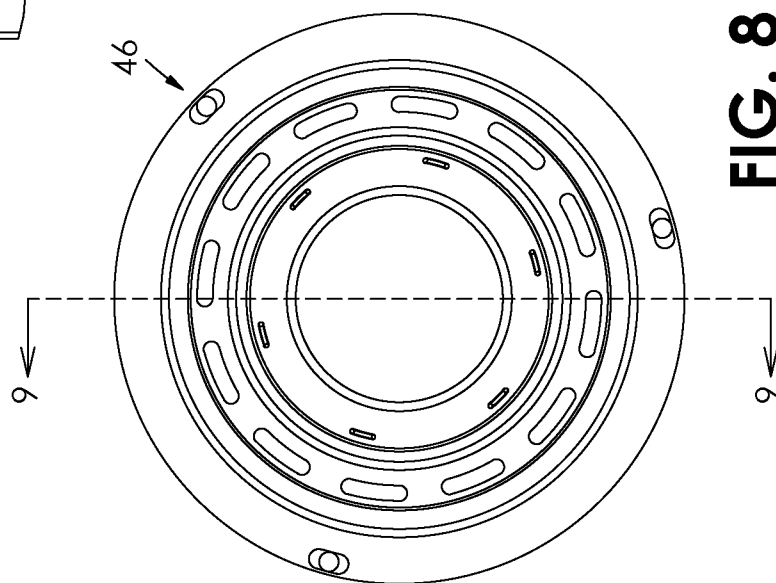

FIG. 8

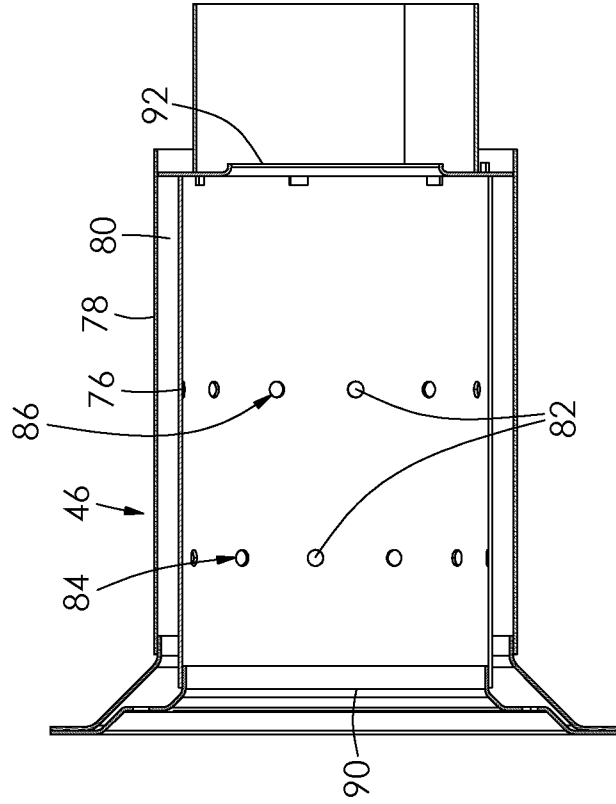

FIG. 9

9/27

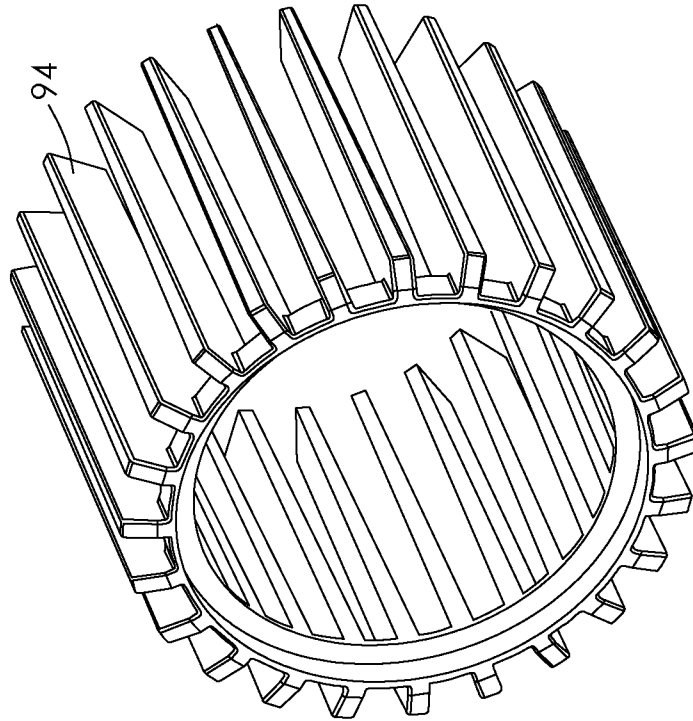

FIG. 12

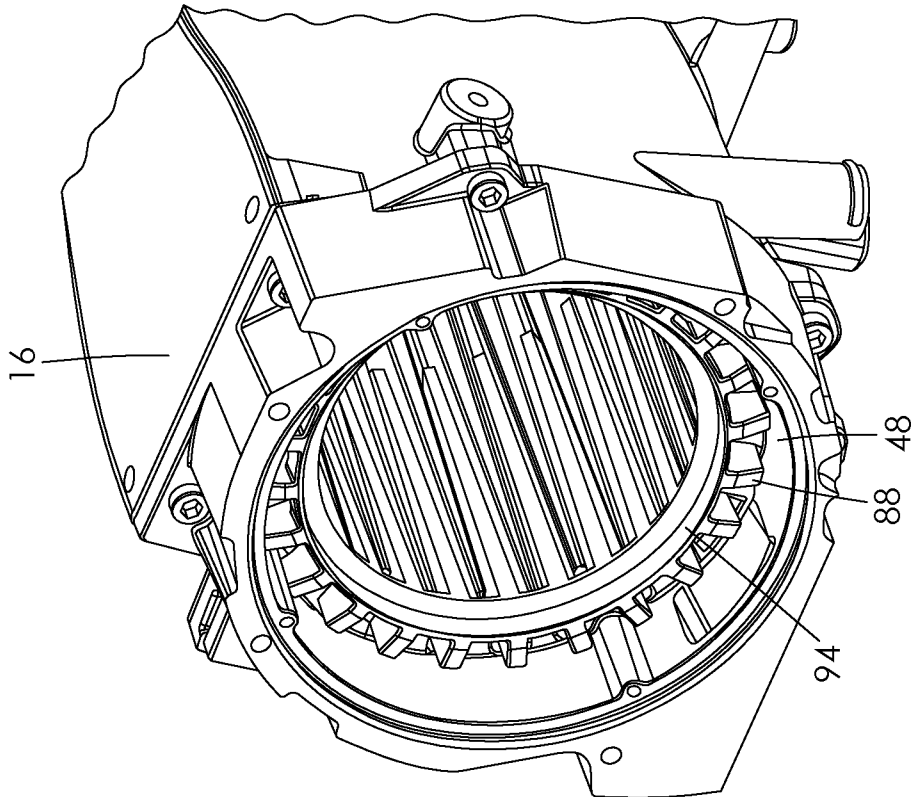

FIG. 11

10/27

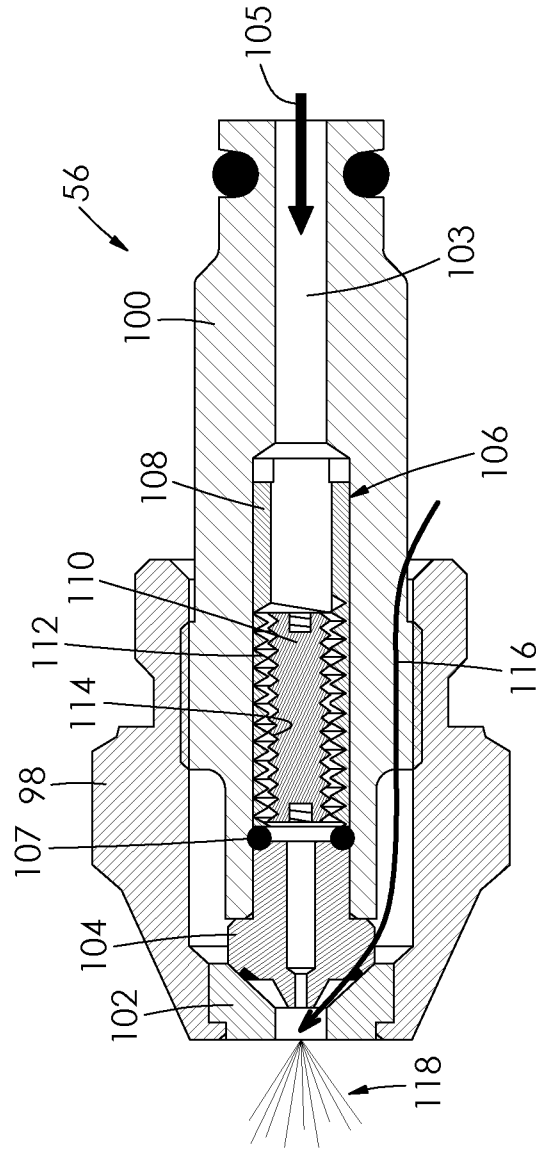

FIG. 13

11/27

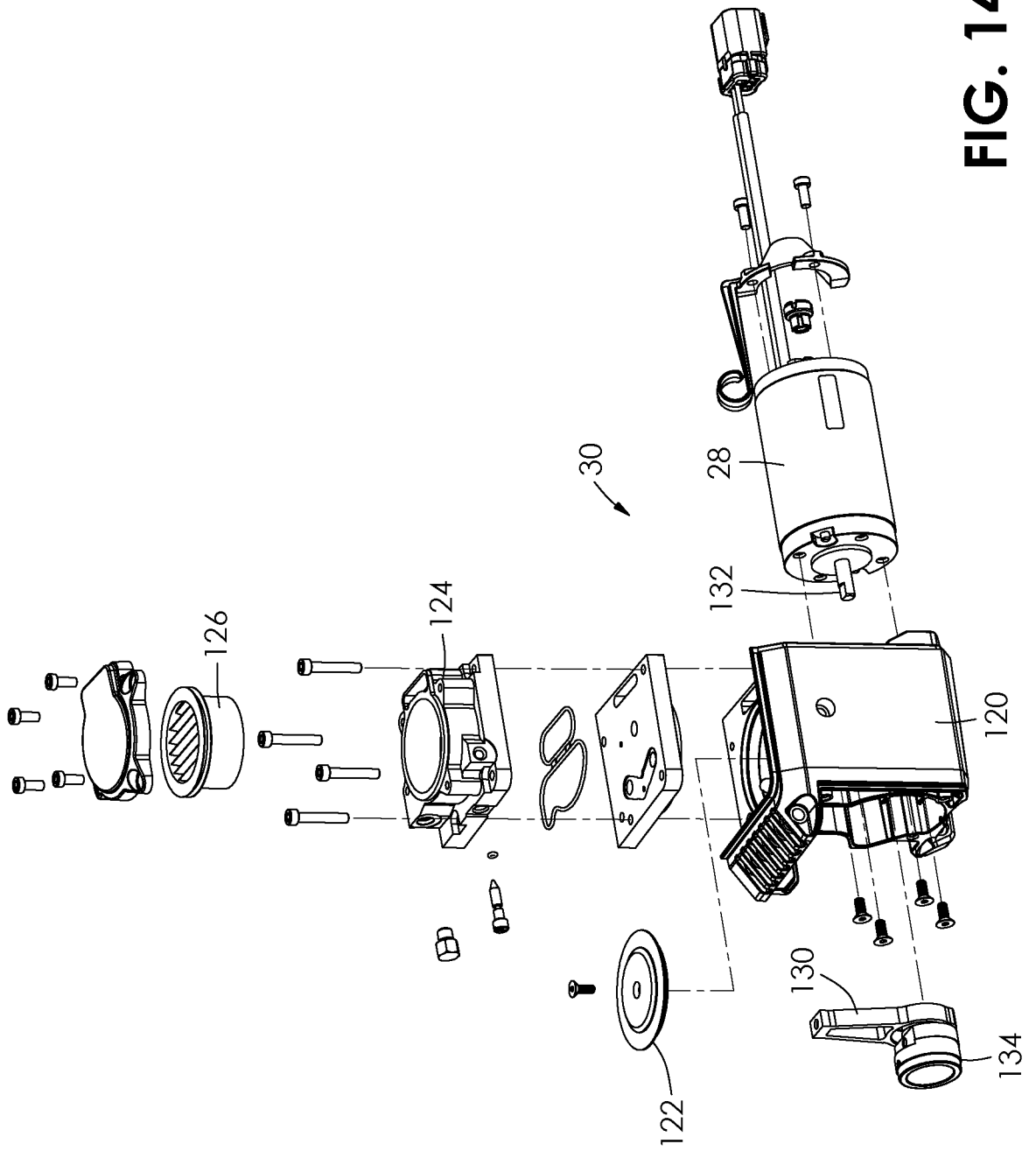

FIG. 14

12/27

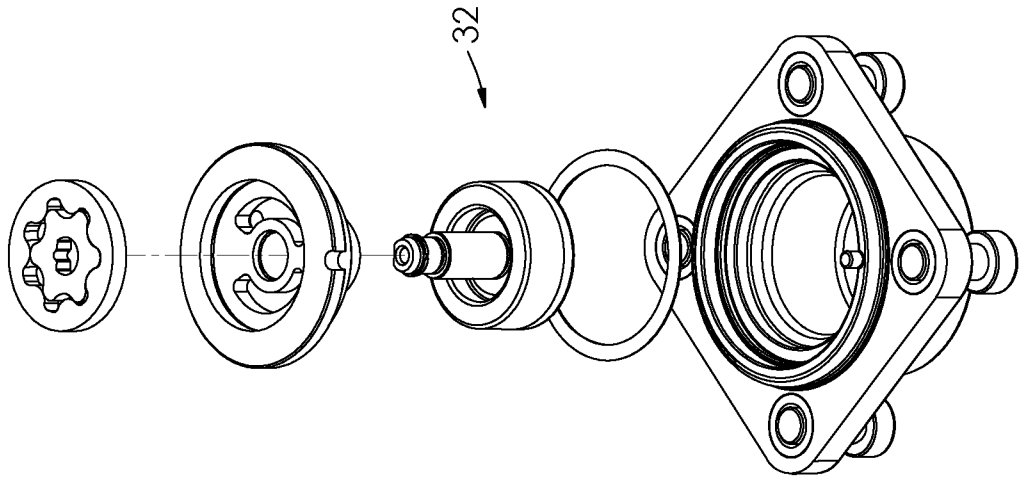

FIG. 15B

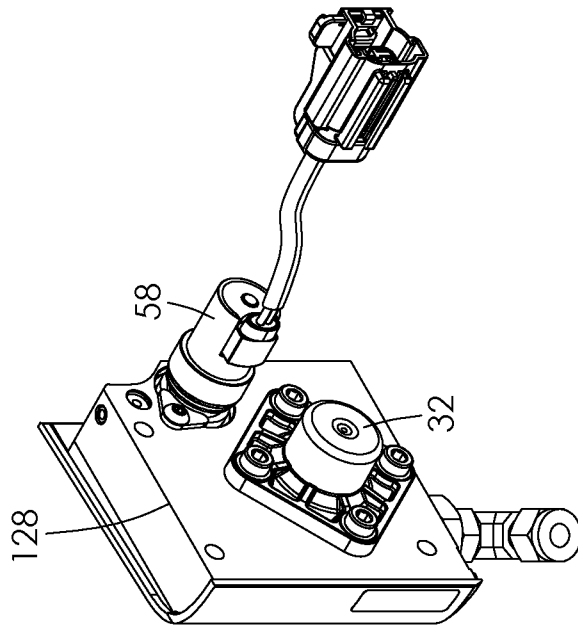

FIG. 15A

13/27

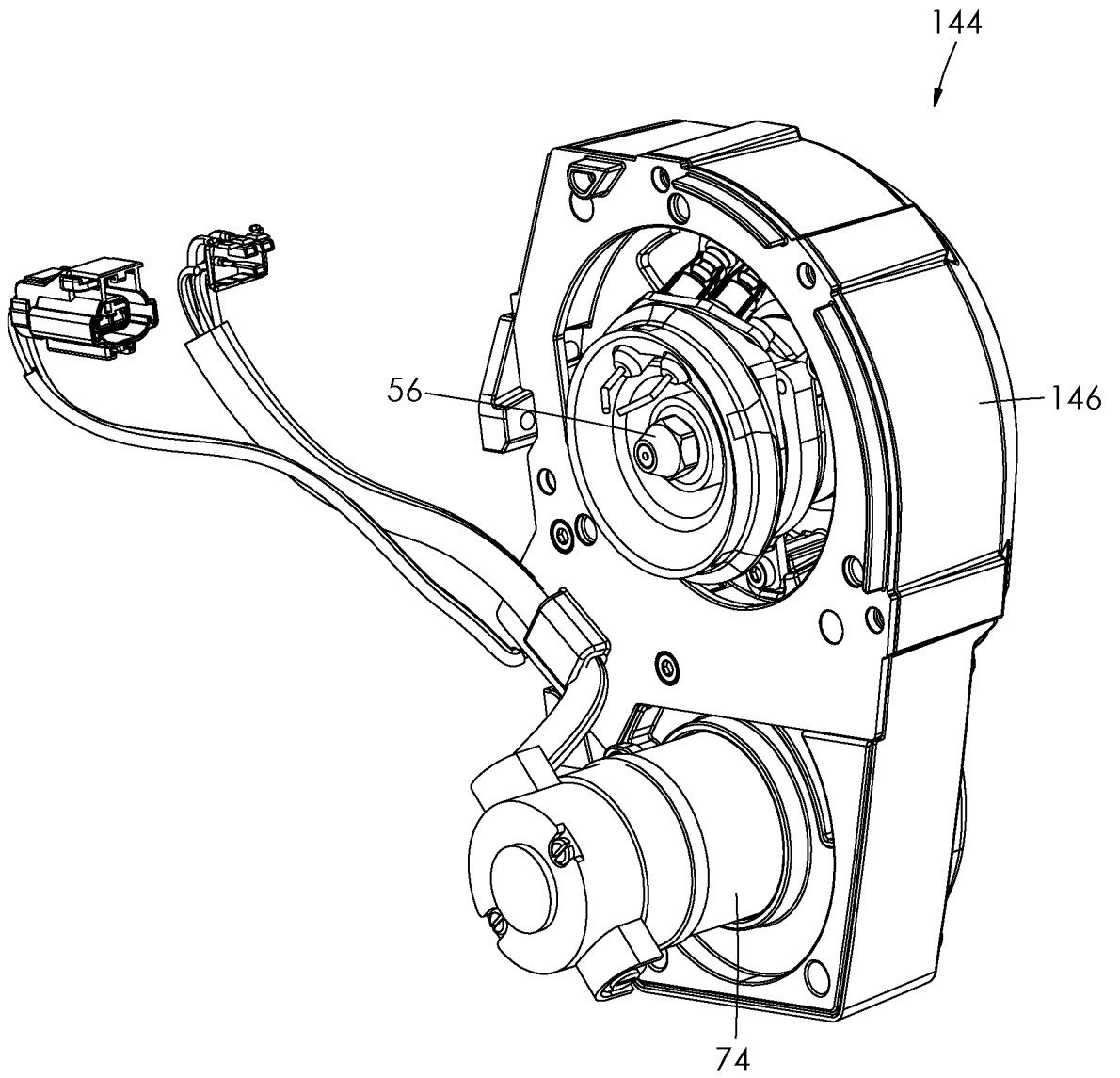

FIG. 16

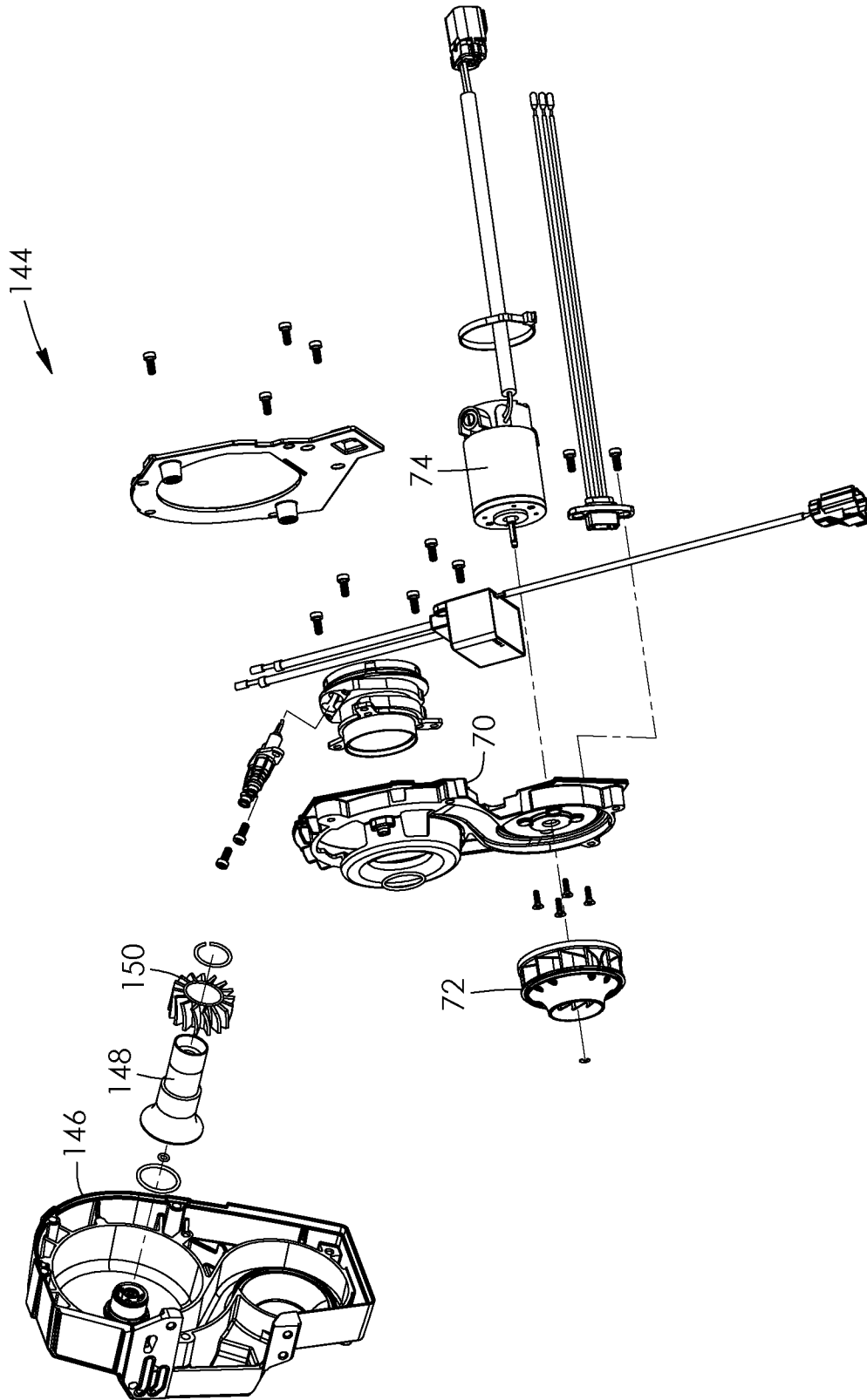

FIG. 17

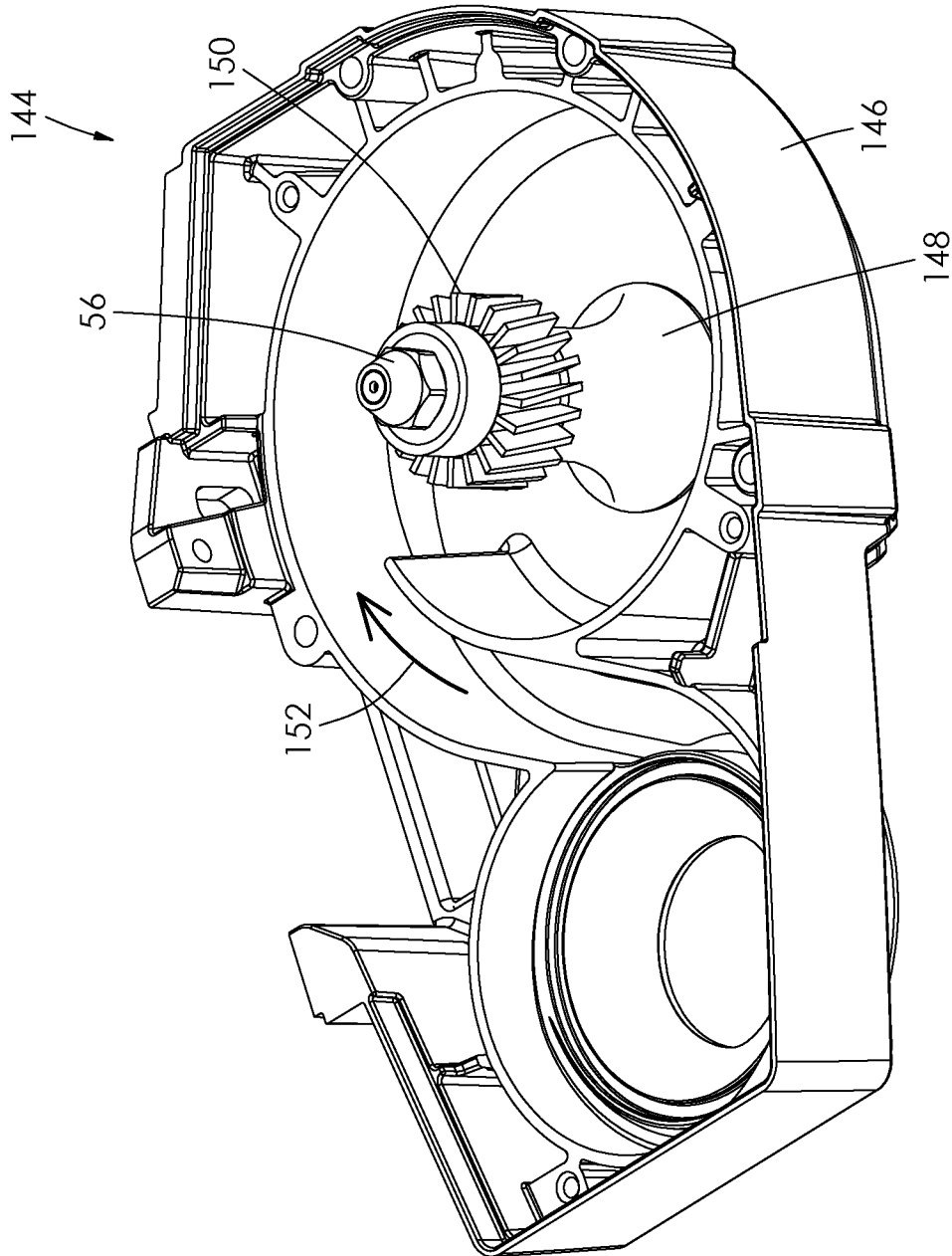

FIG. 18

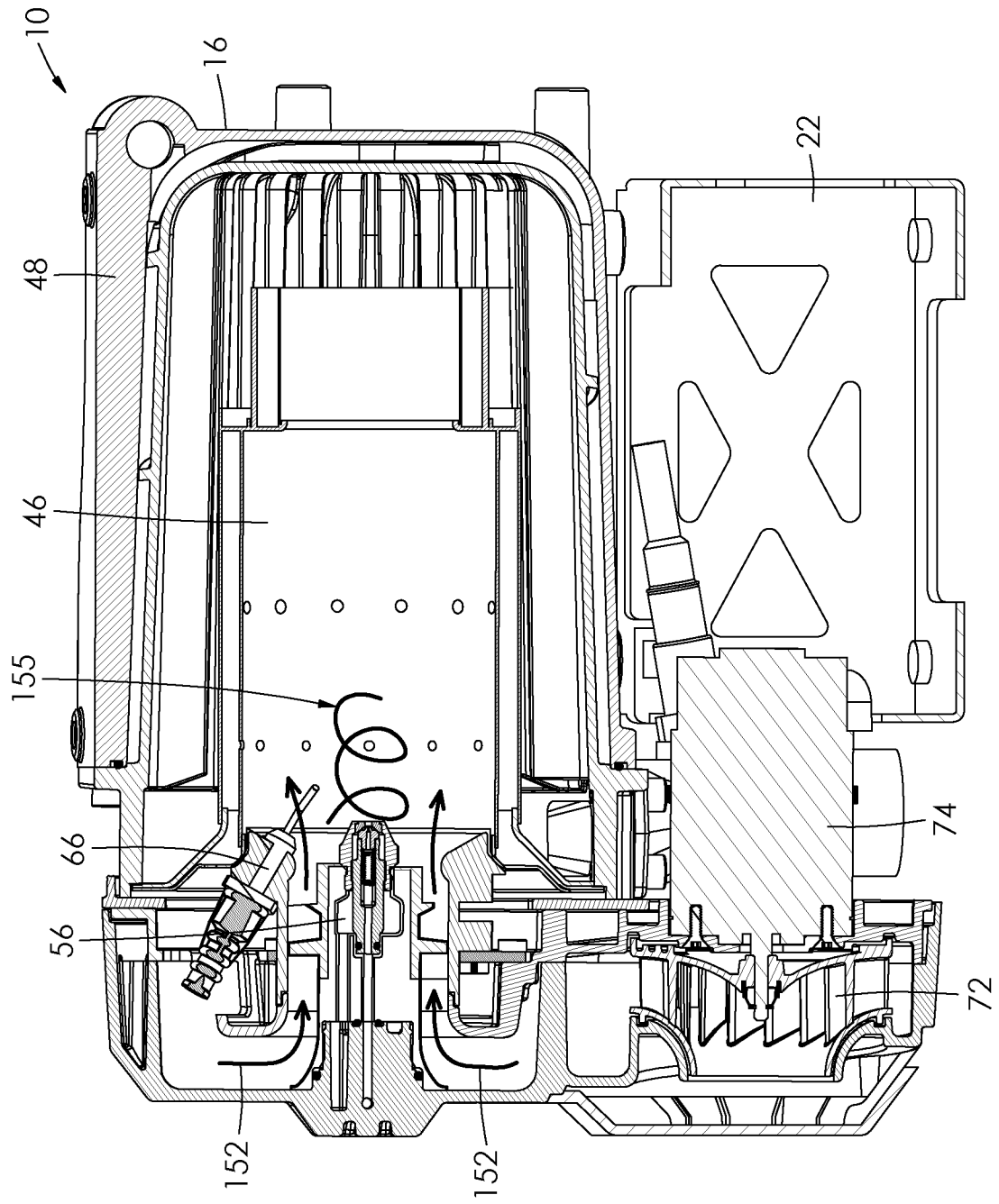

FIG. 19

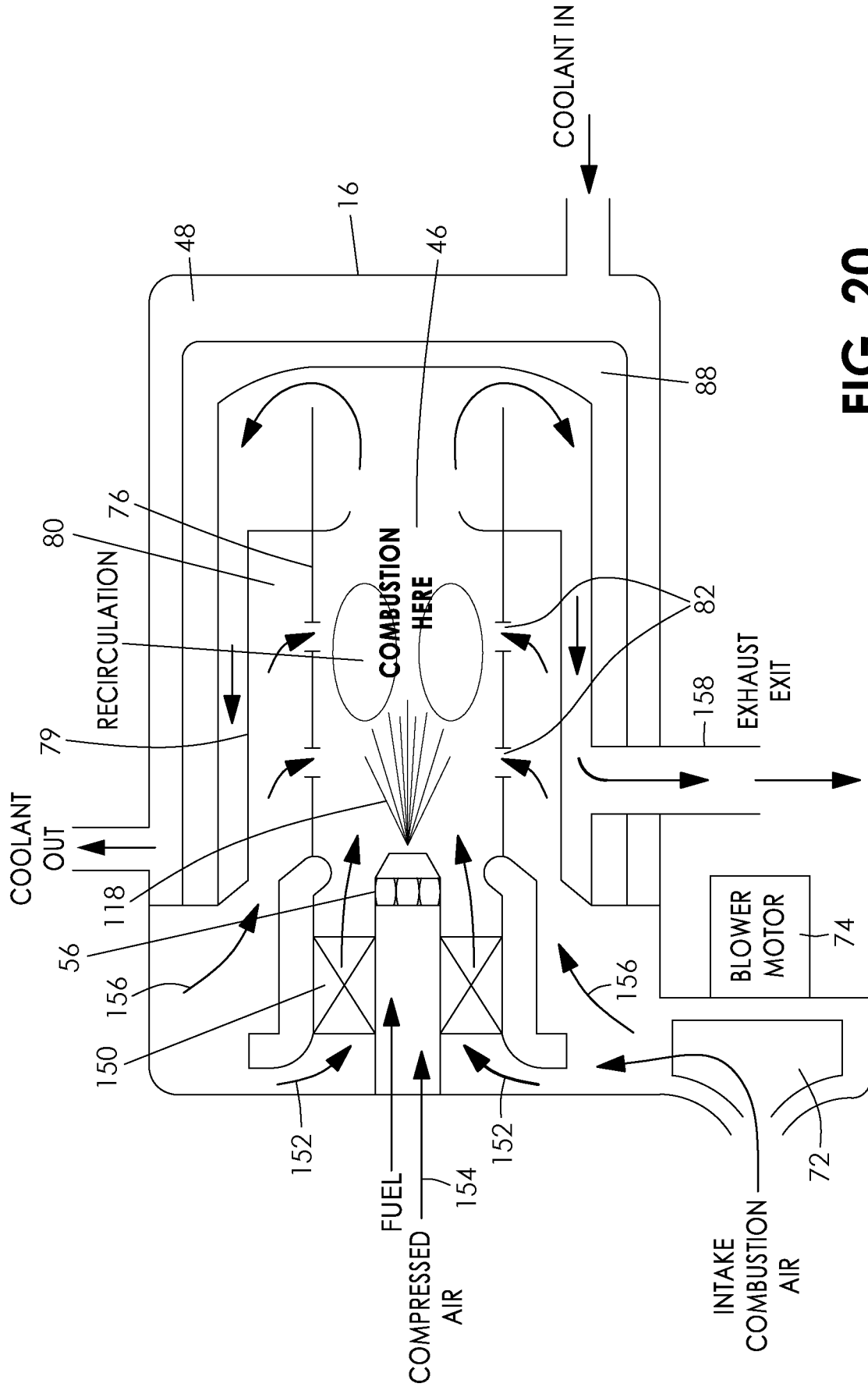

FIG. 20

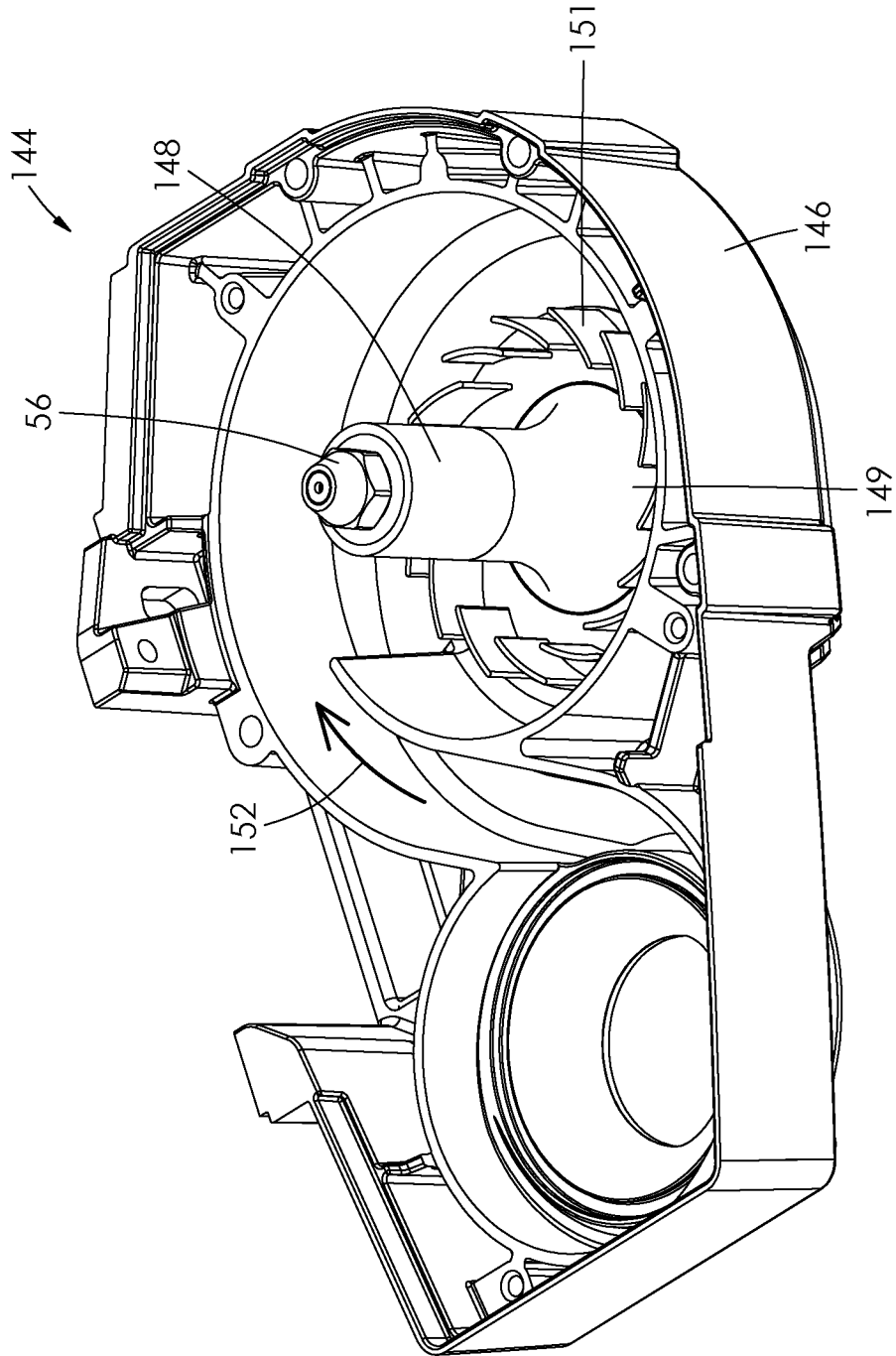

FIG. 21

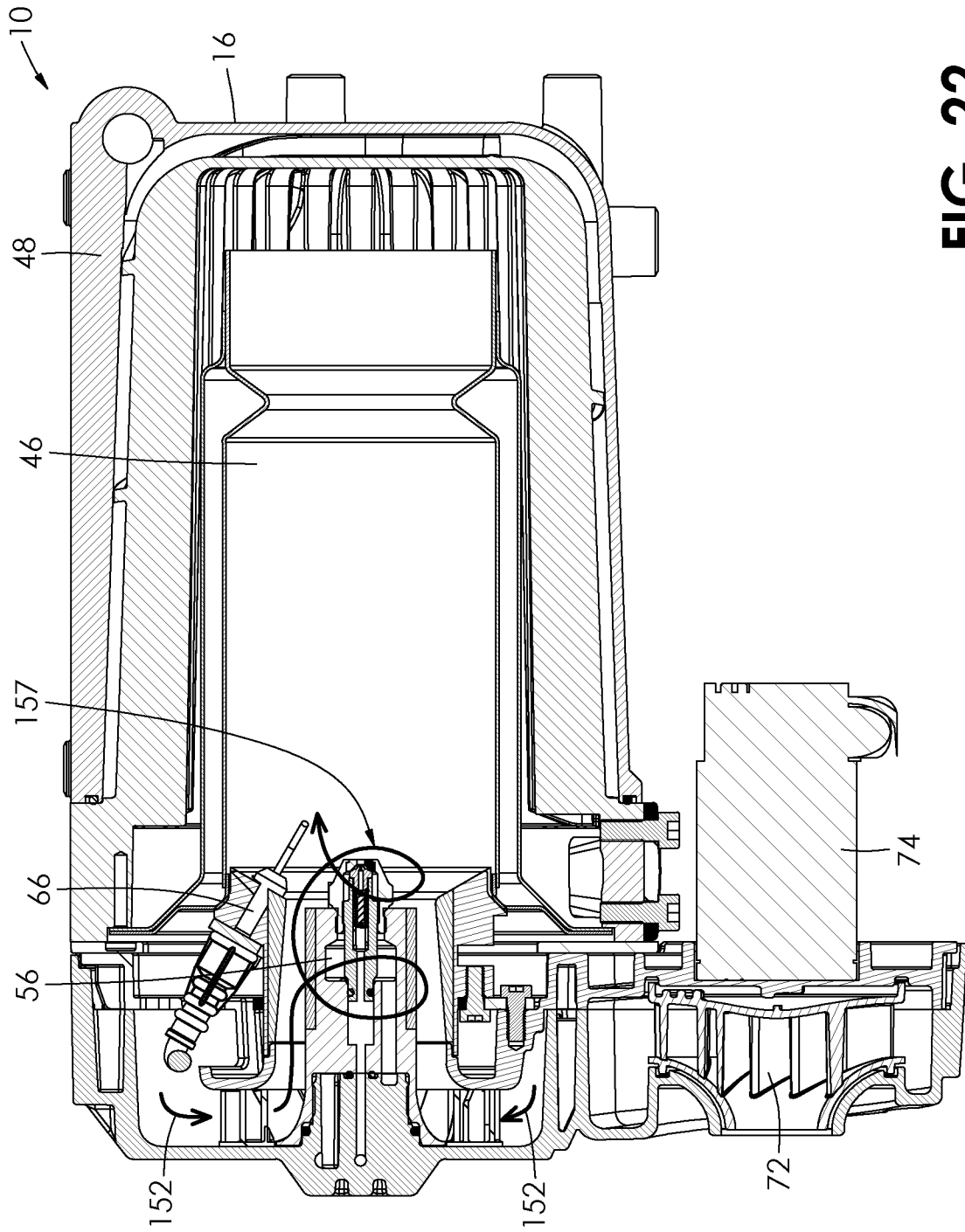

FIG. 22

20/27

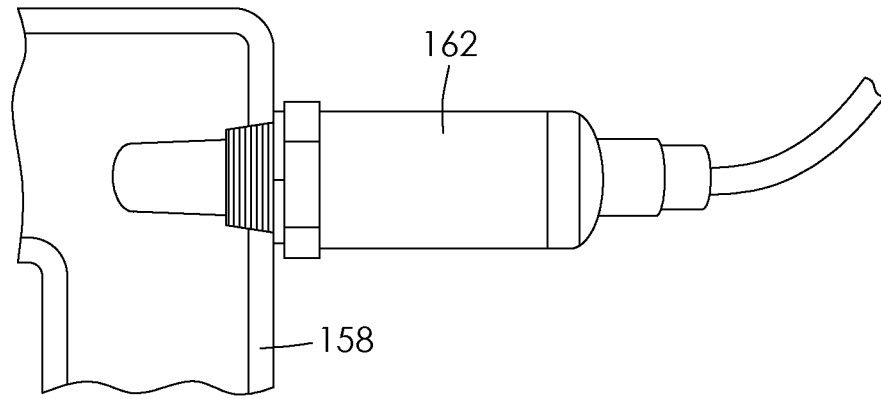

FIG. 23

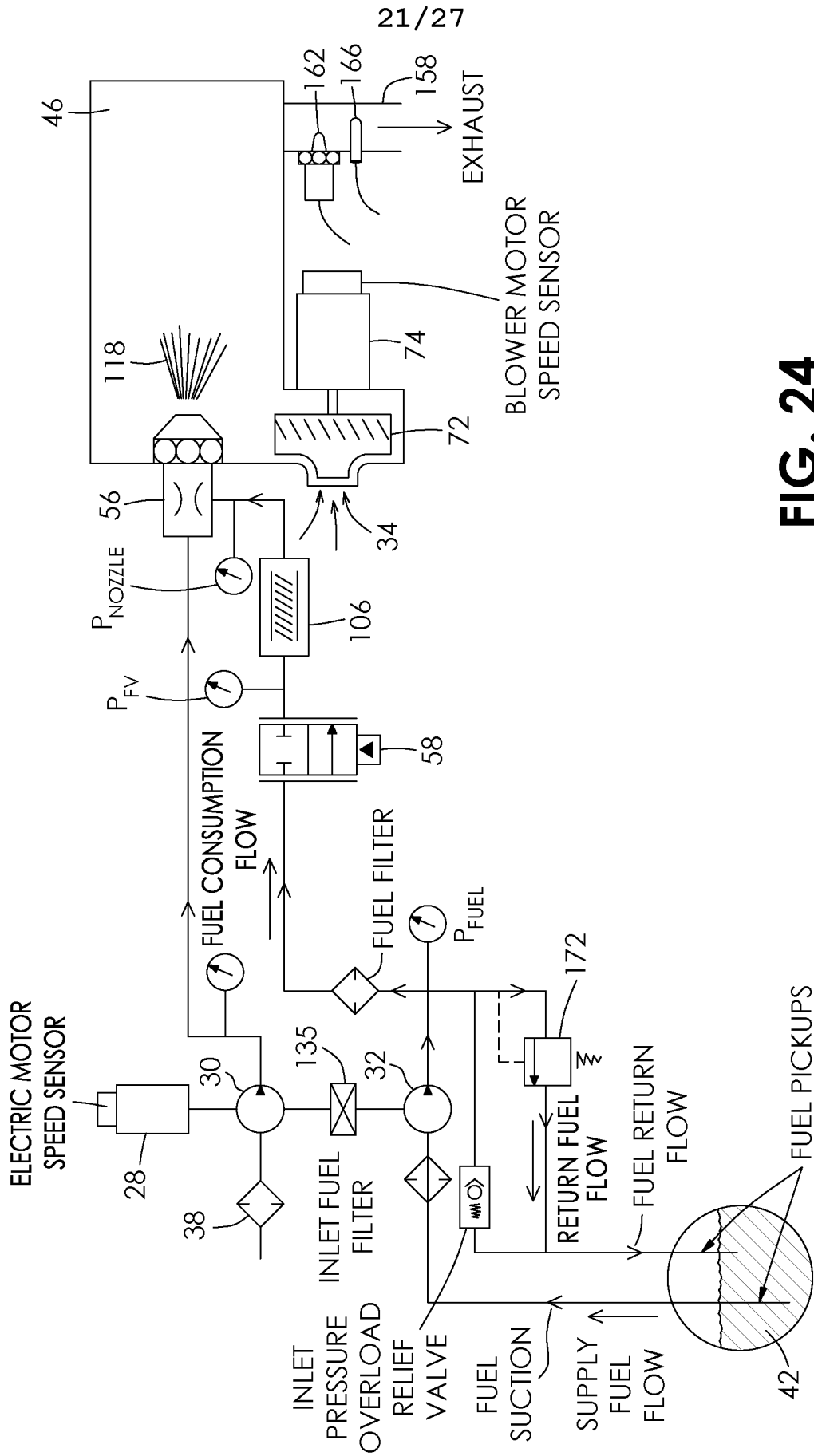

FIG. 24

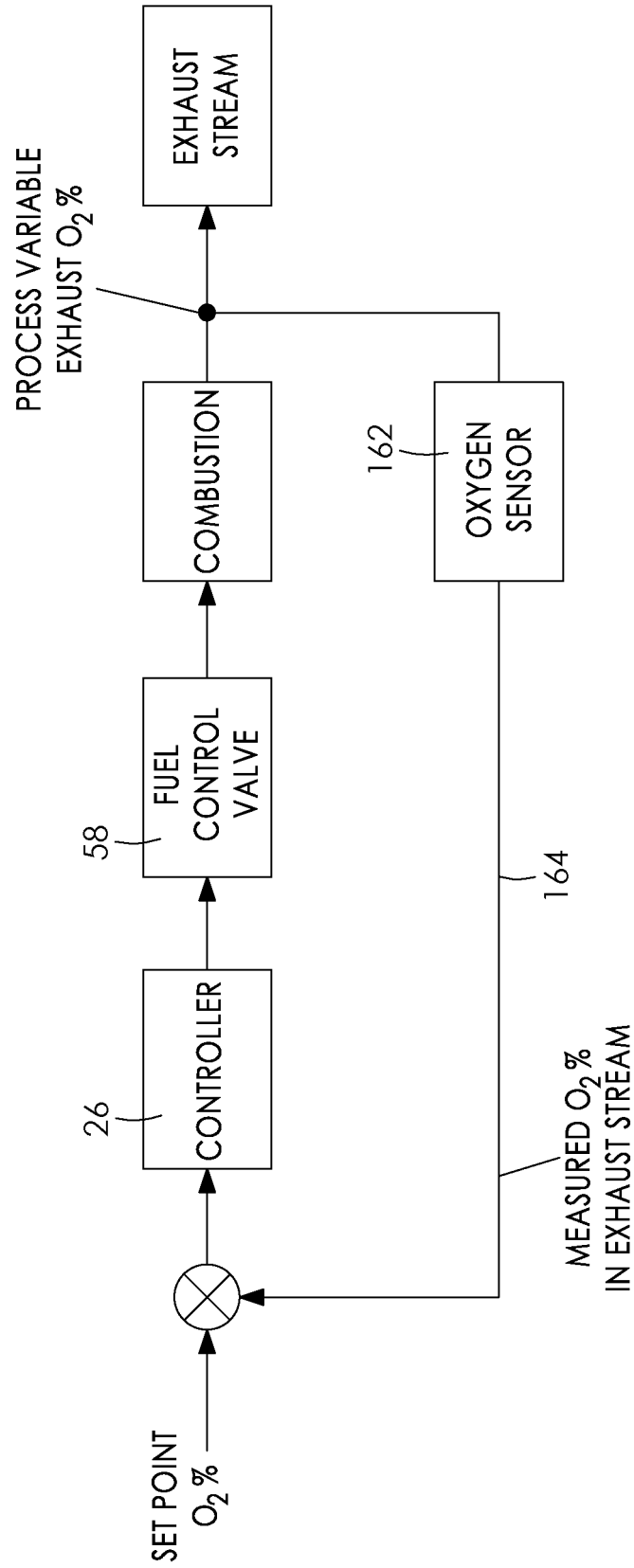

FIG. 25

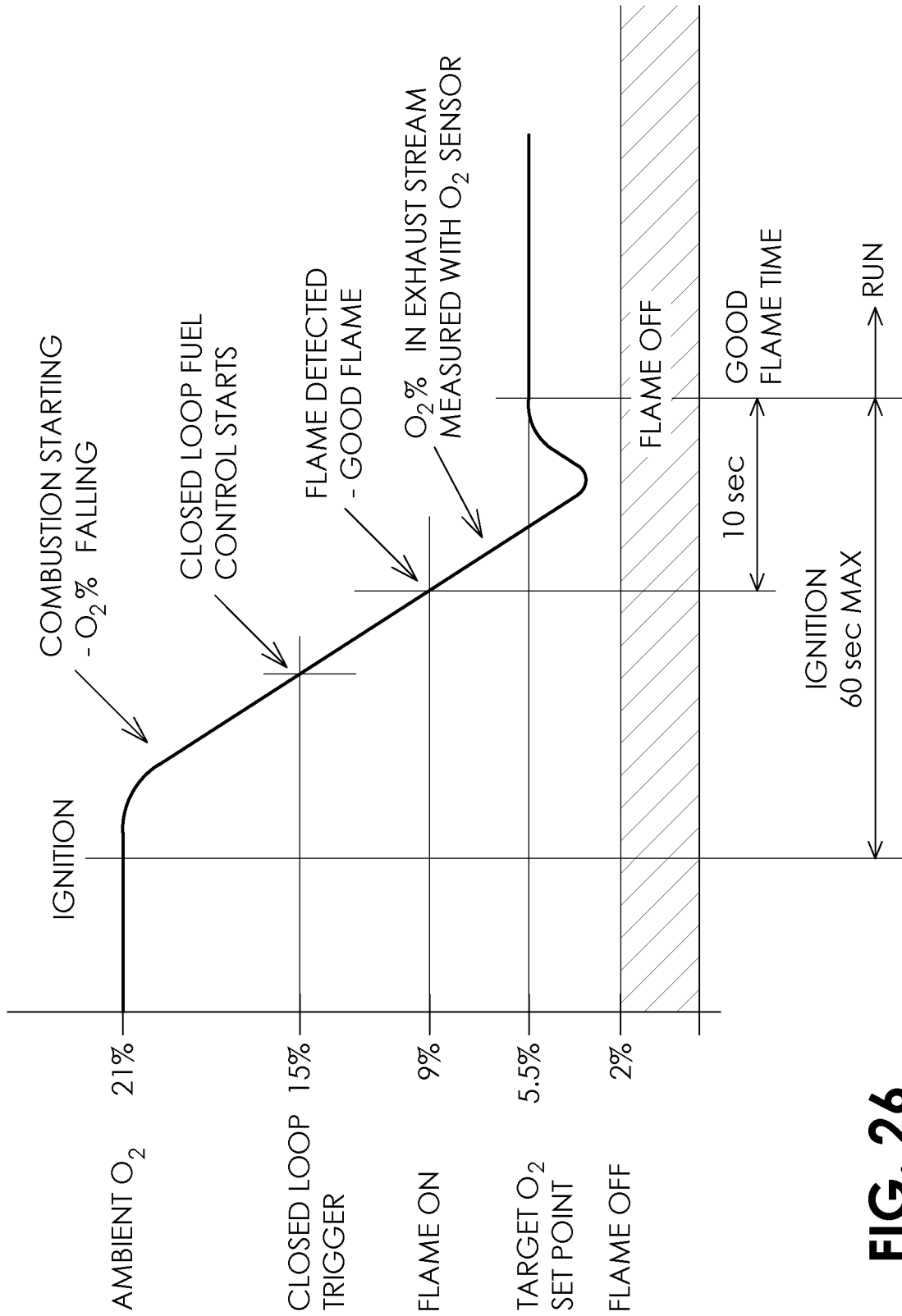

FIG. 26

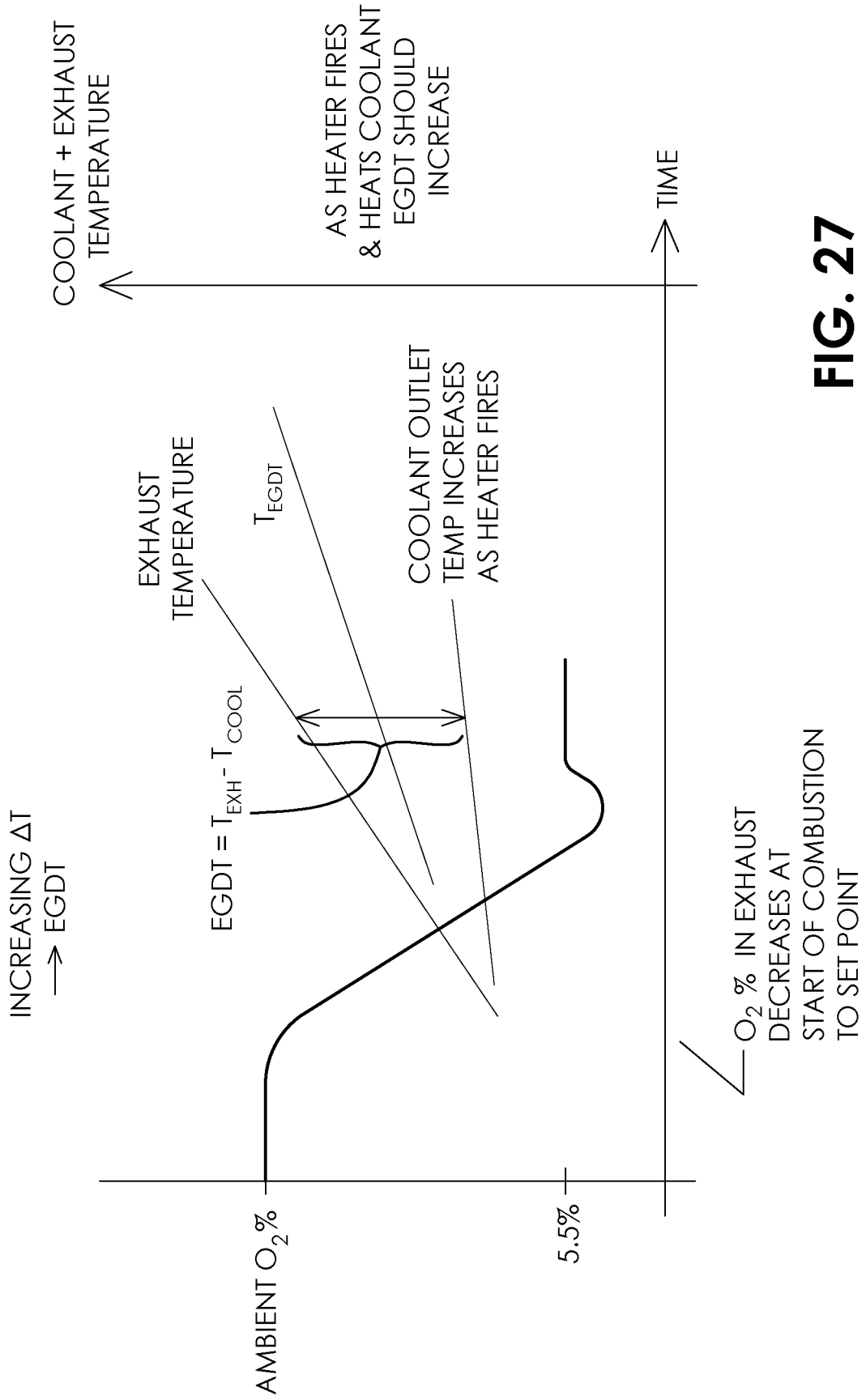

FIG. 27

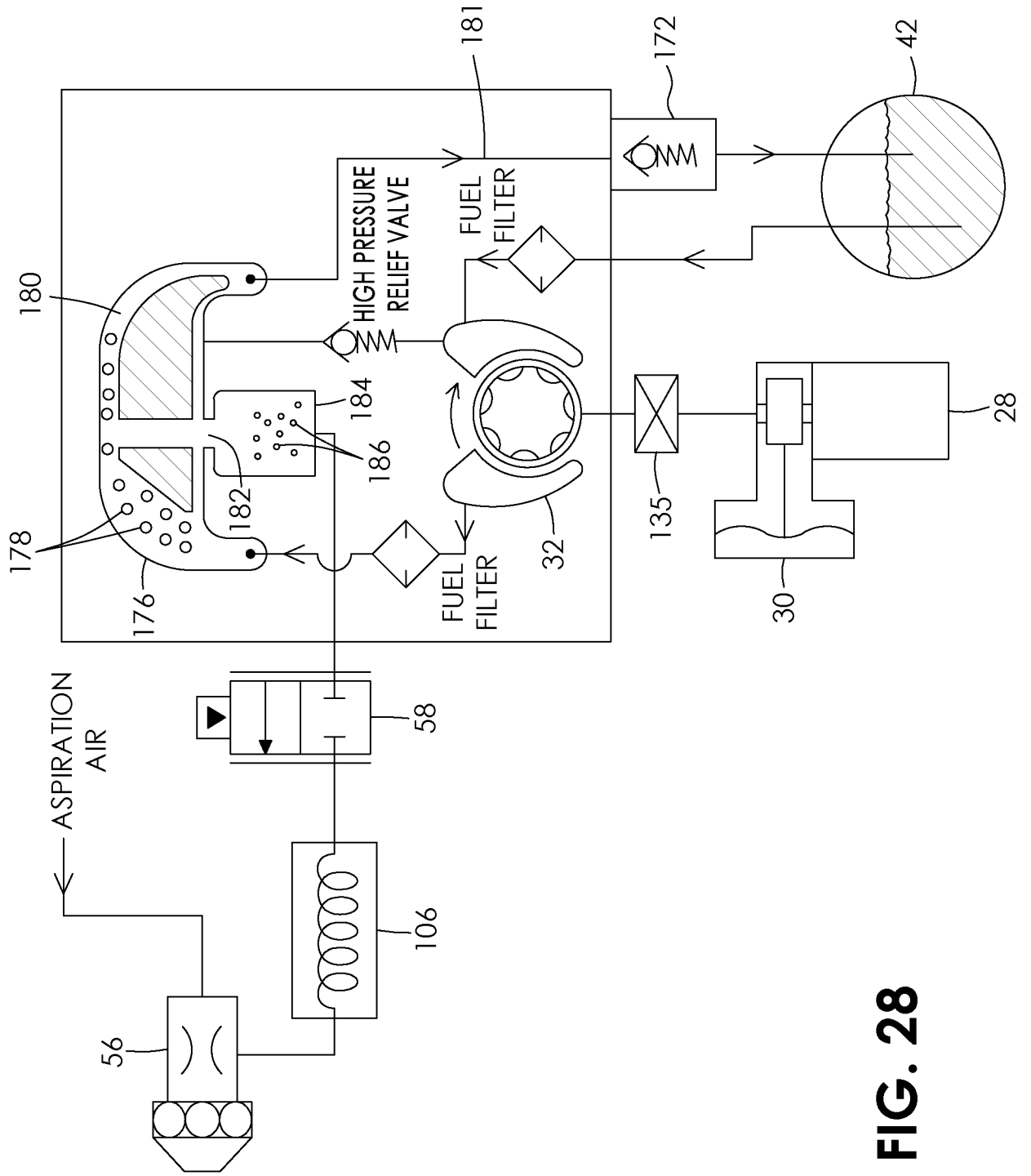

FIG. 28

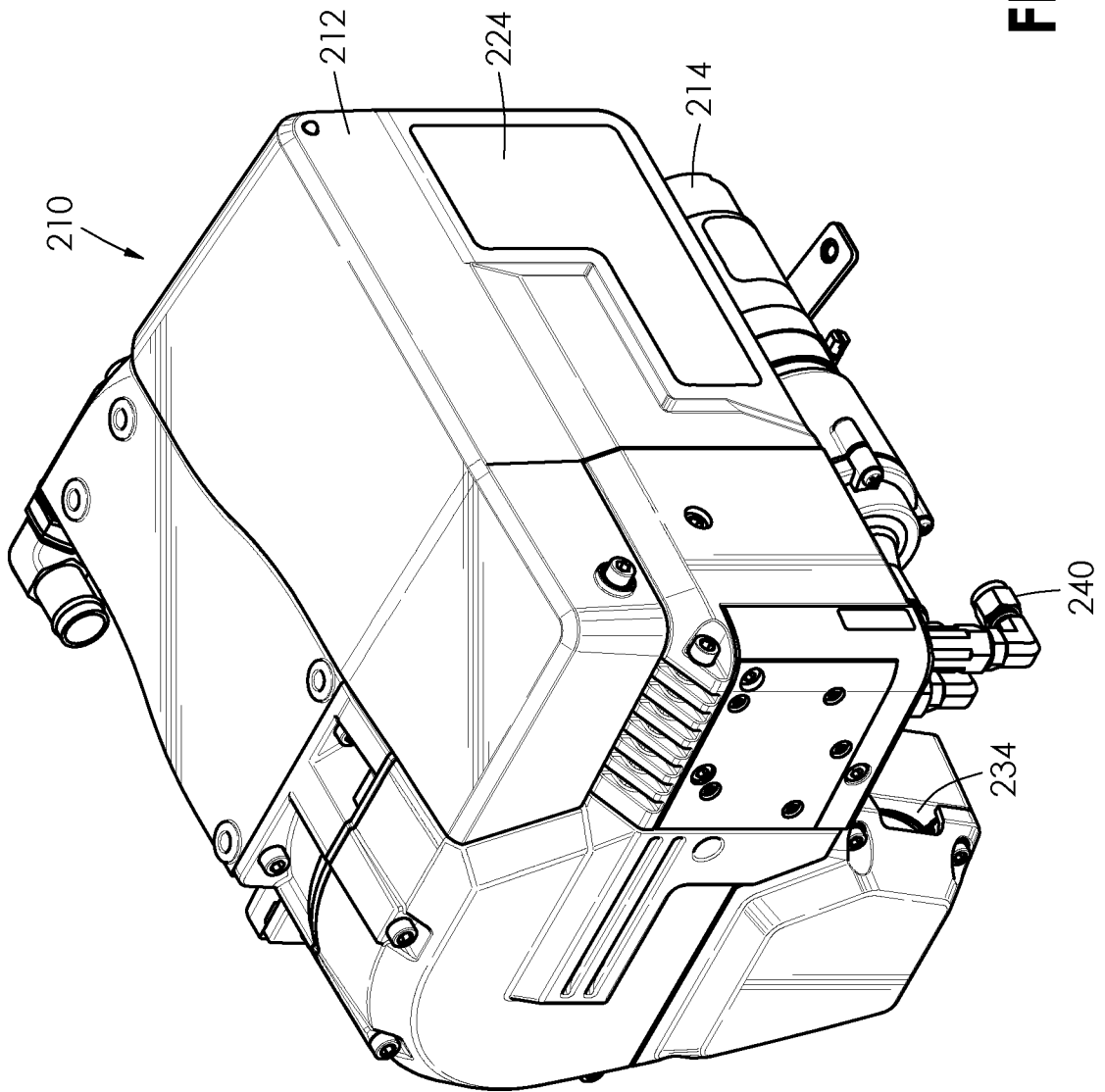
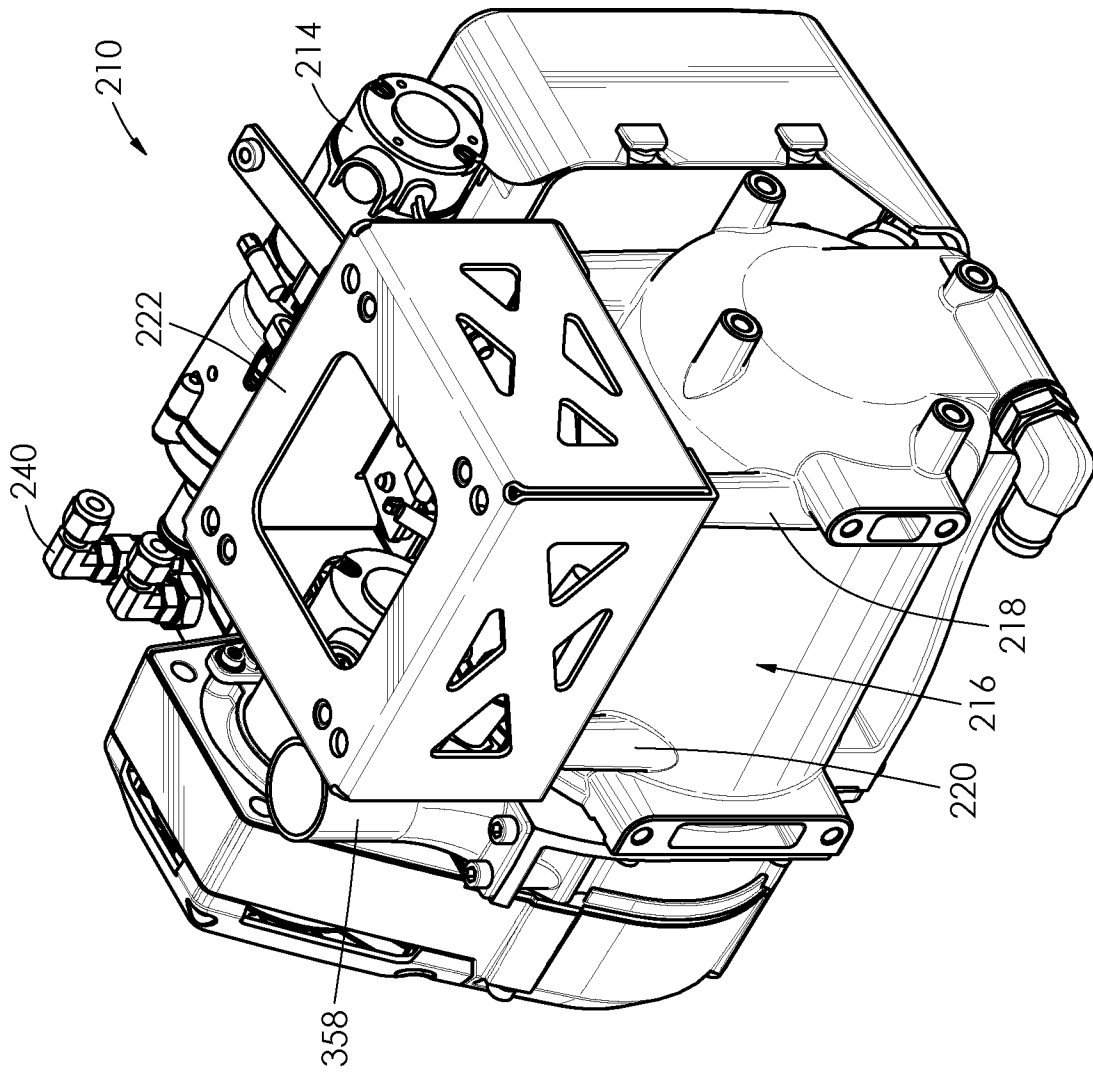

FIG. 29

FIG. 30



INTERNATIONAL SEARCH REPORT

International application No.

PCT/CA2017/050391

A. CLASSIFICATION OF SUBJECT MATTER
 IPC: *F24H 1/22* (2006.01), *F02N 19/10* (2010.01), *F23N 5/26* (2006.01), *F24H 1/08* (2006.01), *F24H 9/20* (2006.01)

According to International Patent Classification (IPC) or to both national classification and IPC

B. FIELDS SEARCHED

Minimum documentation searched (classification system followed by classification symbols)

IPC: *F24H 1/22* (2006.01); *F02N 19/10* (2010.01); *F23N 5/26* (2006.01); *F24H 1/08* (2006.01); *F24H 9/20* (2006.01); *F23N 1/02* (2006.01)

Documentation searched other than minimum documentation to the extent that such documents are included in the fields searched

Electronic database(s) consulted during the international search (name of database(s) and, where practicable, search terms used)

Questel-Orbit (FAMPAT). (Keywords: cold start, oxygen sensor, burner, fan, jacket, and similar terms)

C. DOCUMENTS CONSIDERED TO BE RELEVANT

Category*	Citation of document, with indication, where appropriate, of the relevant passages	Relevant to claim No.
A	US20040007196A1 (YOUNG, J. et al.) 15 January 2004 (15-01-2004) *Abstract; figures 1 and 2; paragraph 0065, 0066, 0075-0079, 0104, 0117, 0135, and 0136 *	
A	WO2013025250A1 (FIORITI, G. et al.) 21 February 2013 (21-02-2013) * Abstract; figures 4 and 9; paragraph 0039 *	
A	US20050258263A1 (ROBINSON, E.) 24 November 2005 (24-11-2005) * Abstract; figure 1A; paragraph 0024 *	

Further documents are listed in the continuation of Box C.

See patent family annex.

* "A" "E" "L" "O" "P"	Special categories of cited documents: document defining the general state of the art which is not considered to be of particular relevance earlier application or patent but published on or after the international filing date document which may throw doubts on priority claim(s) or which is cited to establish the publication date of another citation or other special reason (as specified) document referring to an oral disclosure, use, exhibition or other means document published prior to the international filing date but later than the priority date claimed	"T" "X" "Y" "&"	later document published after the international filing date or priority date and not in conflict with the application but cited to understand the principle or theory underlying the invention document of particular relevance; the claimed invention cannot be considered novel or cannot be considered to involve an inventive step when the document is taken alone document of particular relevance; the claimed invention cannot be considered to involve an inventive step when the document is combined with one or more other such documents, such combination being obvious to a person skilled in the art document member of the same patent family
--------------------------------------	--	--------------------------	--

Date of the actual completion of the international search
09 June 2017 (09-06-2017)

Date of mailing of the international search report
27 June 2017 (27-06-2017)

Name and mailing address of the ISA/CA
 Canadian Intellectual Property Office
 Place du Portage I, C114 - 1st Floor, Box PCT
 50 Victoria Street
 Gatineau, Quebec K1A 0C9
 Facsimile No.: 819-953-2476

Authorized officer

Paul Bourgeois (819) 639-6080

Box No. II Observations where certain claims were found unsearchable (Continuation of item 2 of the first sheet)

This international search report has not been established in respect of certain claims under Article 17(2)(a) for the following reasons:

1. Claim Nos.:
because they relate to subject matter not required to be searched by this Authority, namely:

2. Claim Nos.:
because they relate to parts of the international application that do not comply with the prescribed requirements to such an extent that no meaningful international search can be carried out, specifically:

3. Claim Nos.:
because they are dependent claims and are not drafted in accordance with the second and third sentences of Rule 6.4(a).

Box No. III Observations where unity of invention is lacking (Continuation of item 3 of first sheet)

This International Searching Authority found multiple inventions in this international application, as follows:

See extra sheet

1. As all required additional search fees were timely paid by the applicant, this international search report covers all searchable claims.
2. As all searchable claims could be searched without effort justifying additional fees, this Authority did not invite payment of additional fees.
3. As only some of the required additional search fees were timely paid by the applicant, this international search report covers only those claims for which fees were paid, specifically claim Nos.:

4. No required additional search fees were timely paid by the applicant. Consequently, this international search report is restricted to the invention first mentioned in the claims; it is covered by claim Nos.: 1-11

- Remark on Protest**
- The additional search fees were accompanied by the applicant's protest and, where applicable, the payment of a protest fee.
 - The additional search fees were accompanied by the applicant's protest but the applicable protest fee was not paid within the time limit specified in the invitation.
 - No protest accompanied the payment of additional search fees.

Continuation of: Box No. III

The claims are directed to a plurality of inventive concepts as follows:

Group A - Claims 1-11 are directed to a fluid heater system featuring a fuel delivery system having a variable delivery rate; an exhaust system extending from the combustion chamber; an oxygen sensor positioned in the exhaust system to detect oxygen content of exhaust gases; and a control system operatively coupled to the oxygen sensor and the fuel delivery system, the control system controlling the delivery rate of the fuel delivery system according to the oxygen content of the exhaust gases; and

Group B - Claims 12-15 are directed to a fluid heater system featuring a fuel delivery system including a fuel pump; and an air compressor, the air compressor having an output communicating with the burner to supply compressed air thereto; wherein the burner includes a nozzle having a disparager assembly, the disparager assembly including an outer barrel having a threaded inner wall portion and an inner rod having a threaded outer wall portion, the threaded inner wall portion and the threaded outer wall portion having different thread pitches.

The features shared by the independent claims are known from prior art document US20050258263A1 (ROBINSON, E.) 24 November 2005 (24-11-2005) which teaches a heater for a liquid (see the abstract), the heater comprising: a combustion chamber (101); a jacket (110) for the liquid, the jacket extending about the combustion chamber (see figure 1A); a fan (151) having an output communicating with the combustion chamber to provide combustion air; a fuel delivery system (via 152); a burner assembly (102) connected to the combustion chamber, the burner assembly having a burner mounted thereon adjacent the combustion chamber (see figure 1A), the burner receiving fuel from the fuel delivery system (see paragraph 0024, for example).

Where the features shared by the independent claims are already known, these claims lack unity for being directed to different subject matter *a posteriori* the teachings of US20050258263A1 (ROBINSON, E.) 24 November 2005 (24-11-2005).

The claims must be limited to one inventive concept as set out in PCT Rule 13.

INTERNATIONAL SEARCH REPORT
Information on patent family members

International application No.
PCT/CA2017/050391

Patent Document Cited in Search Report	Publication Date	Patent Family Member(s)	Publication Date
US2004007196A1	15 January 2004 (15-01-2004)	US7270098B2 US2006191498A1 US7597552B2 US2010170954A1 US9428036B2 US2005039715A1 US2005039716A1	18 September 2007 (18-09-2007) 31 August 2006 (31-08-2006) 06 October 2009 (06-10-2009) 08 July 2010 (08-07-2010) 30 August 2016 (30-08-2016) 24 February 2005 (24-02-2005) 24 February 2005 (24-02-2005)
WO2013025250A1	21 February 2013 (21-02-2013)	CN103842726A EP2745052A1 EP2745052A4 JP2014527611A JP5969028B2 KR20130065629A KR20150115952A US2013042822A1 US9175853B2	04 June 2014 (04-06-2014) 25 June 2014 (25-06-2014) 08 April 2015 (08-04-2015) 16 October 2014 (16-10-2014) 10 August 2016 (10-08-2016) 19 June 2013 (19-06-2013) 14 October 2015 (14-10-2015) 21 February 2013 (21-02-2013) 03 November 2015 (03-11-2015)
US2005258263A1	24 November 2005 (24-11-2005)	US8118239B2 US2005284948A1 US9074779B2 US2012180736A1	21 February 2012 (21-02-2012) 29 December 2005 (29-12-2005) 07 July 2015 (07-07-2015) 19 July 2012 (19-07-2012)