

[54] REMOVABLE OVEN DOOR HINGE SYSTEM

[75] Inventors: James A. White, Louisville; Peter Nowosielski, Middletown, both of Ky.

[73] Assignee: General Electric Company, Louisville, Ky.

[22] Filed: June 1, 1973

[21] Appl. No.: 366,005

[52] U.S. Cl. .... 49/386, 126/194

[51] Int. Cl. .... E05f 1/10

[58] Field of Search ..... 49/386; 126/191, 194; 403/361

[56] References Cited

UNITED STATES PATENTS

3,132,640	5/1964	Chisholm et al.	126/194
3,329,452	7/1967	Ammon	403/361 X
3,398,735	8/1968	Barber	126/194 X

FOREIGN PATENTS OR APPLICATIONS

705,290	4/1966	Italy	49/386
---------	--------	-------	--------

Primary Examiner—Kenneth Downey

Attorney, Agent, or Firm—Richard L. Caslin; Francis H. Boos

[57] ABSTRACT

A hinge system for a removable door for use on a baking oven. The hinge system includes a pair of hinge mechanisms, where each mechanism includes a stationary support bracket, a pivoted door guide, a separate door guide sleeve in the door for receiving the door guide, a spring-loaded hinge lever pivoted to the door guide, and resilient means between the door guide and door guide sleeve for taking out the slack or wobble of the door on the hinge mechanisms. The support bracket includes a roller assembly that cooperates with the hinge lever to provide a door guide slam-prevention protection. The back half of the hinge lever is designed to be free of the roller assembly to improve the balancing forces on the door. The combined roller assembly and support bracket is adjustably mounted from the door frame to enable the changing of the relative position of the door.

2 Claims, 5 Drawing Figures

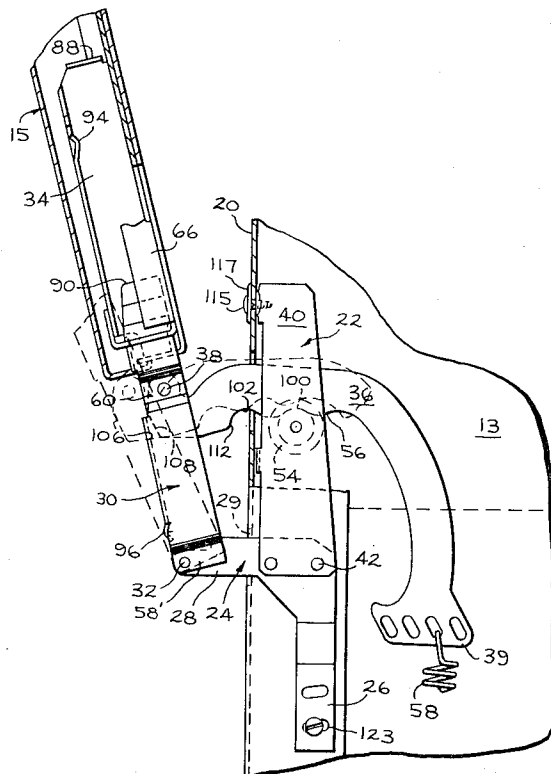



FIG. 2

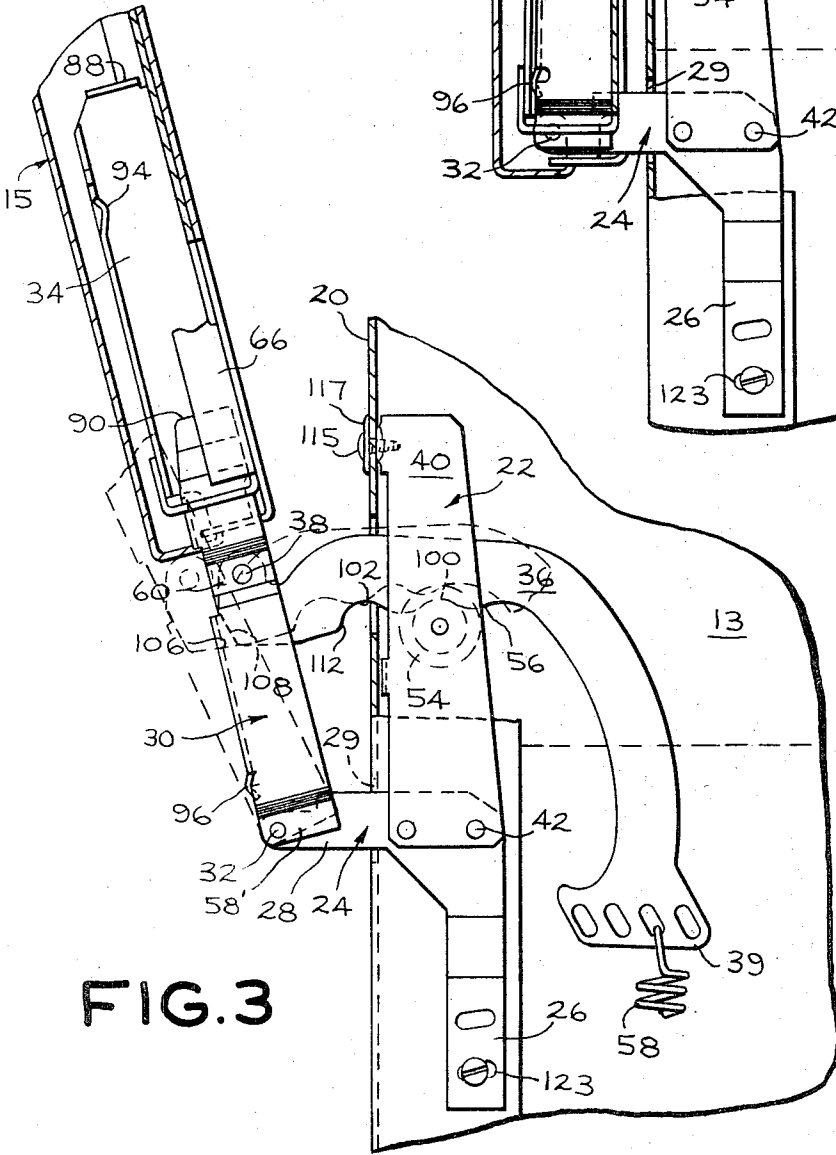
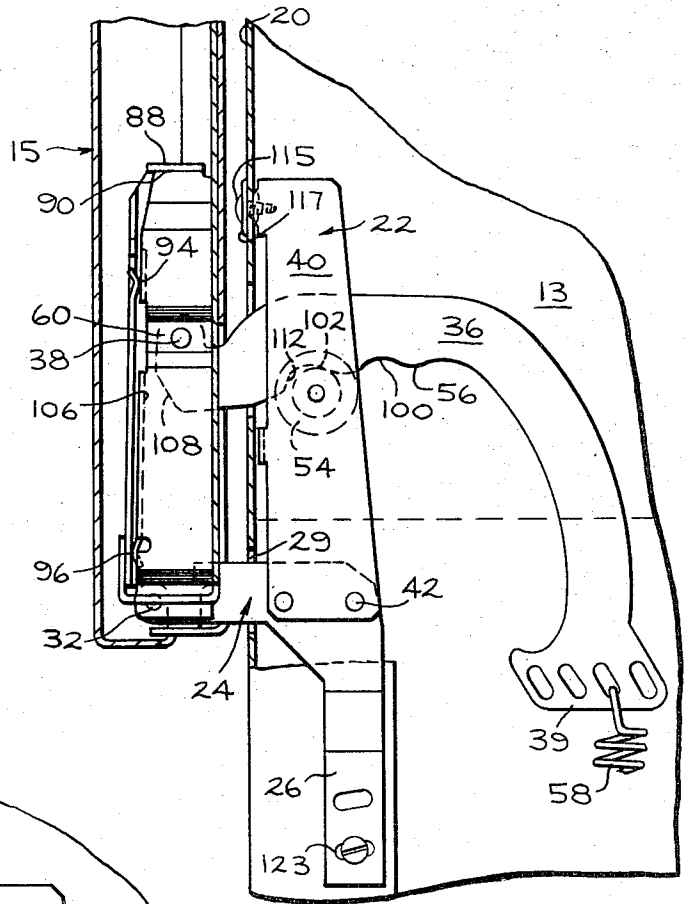

FIG. 3

## REMOVABLE OVEN DOOR HINGE SYSTEM

### BACKGROUND OF THE INVENTION

The repeated use of a cooking oven occasions the gradual accumulation of food soil and grease spatter on the interior walls of the cooking cavity. This unsightly accumulation must be cleaned off periodically by the use of strong chemicals and rubber gloves for the protection of the hands. Of course, there are improved oven designs using an automatic pyrolytic self-cleaning oven system which does not create a problem to the user in maintaining the oven clean. Such an automatic system is taught in a basic patent of Bohdan Hurko, U.S. Pat. No. 3,121,158, which is assigned to the assignee of the present invention.

A standard cooking oven has a counter-balance drop door that is hinged along its bottom edge so that it may move smoothly between a fully closed vertical position and a fully open horizontal position. The scrubbing of the interior of the oven liner is difficult when the oven door is placed in its horizontal fully open position because it is difficult to reach the back wall and top wall deep into the oven cavity.

This problem has been alleviated in recent years by providing many oven models with removable doors where the door may readily be lifted and replaced by the user without the use of any tools. One shortcoming in such removable oven door designs is that the doors tend to fit loosely on the hinge mechanisms and develop a slack or wobble action such that when the door is moved from one position to the other the door tends to lead the movement of the hinge mechanism supporting the door.

The principal object of the present invention is to provide a hinge mechanism for a removable door to reduce wobble action of the door relative to the hinge mechanism.

A further object of the present invention is to provide a removable door hinge mechanism with an integral slam-prevention protection that is automatic in operation and need not be manually engaged and disengaged.

A further object of the present invention is to provide a hinging system for a removable door where the hinging system may be manually adjusted so as to be able to adjust the relative position of the door with respect to the door frame.

A still further object of the present invention is to provide a hinging mechanism of the class described where the hinge lever is free of the roller assembly toward the last half of the door opening operation to improve the door balancing characteristics of the hinge mechanism.

### SUMMARY OF THE INVENTION

The present invention, in accordance with one form thereof, relates to an appliance having an outer cabinet and a front-opening access door. The cabinet includes a front frame forming a door opening and a counterbalanced hinge system connecting the door to the cabinet so the door may move between a vertical closed position and a horizontal open position. The hinge system includes a pair of hinge mechanisms upon which the door is removably mounted. Each hinge mechanism comprises a support bracket having a door guide pivotally connected thereto. A hinge lever is pivotally con-

nected to the door guide, and the free end of the hinge lever is supplied with a door counterbalance spring. A door guide sleeve is mounted within the door for receiving the related door guide. Resilient means act between the door guide and the door guide sleeve to cause a tight fit between these two members and retard relative movement between the door and the hinge mechanism in the direction of pivotal movement of the door. Another feature is that the hinge mechanism includes a hinge lever in cooperation with a roller assembly where the hinge lever includes a slam-protection stop that is adapted to engage the front side of the roller as the door guide sleeve approaches the front frame of the appliance cabinet. Another important feature of this invention relates to a means for adjusting the position of the door with relation to the front frame. Finally, the hinge lever of the hinge mechanism is designed so that during the second half of the travel of the door away from its vertical closed position the hinge lever is moved out of engagement with the roller assembly so as to improve the door balancing action of the hinge mechanism.

### BRIEF DESCRIPTION OF THE DRAWINGS

This invention will be better understood from the following description taken in conjunction with the accompanying drawings and its scope will be pointed out in the appended claims.

FIG. 1 is a perspective view of a free-standing range incorporating a cooking oven having a removable oven door mounted on a hinging system embodying the present invention.

FIG. 2 is a fragmentary, cross-sectional, elevational view looking at the lower right corner of the oven door and hinge mechanism of FIG. 1 taken on the line 2-2.

FIG. 3 is a fragmentary, cross-sectional view similar to that of FIG. 2 showing the oven door pivoted to its partially open broil position and the oven door slightly raised off of its hinge mechanism. This view also shows in dotted lines the oven door pivoted further to an open position beyond about 25° from the fully closed vertical position to show the nature of the last half of the hinge lever being out of engagement with the roller to improve the balancing action afforded by the spring on the door as the door moves between its open and closed positions such that any overbalance of the door will tend to open the door rather than to have the door close by itself.

FIG. 4 is a fragmentary perspective view of one of the pair of hinge mechanisms on which the oven door is adapted to be supported showing the hinge mechanism in its partially open broil position which is the position at which the oven door is designed to be removed and reinstalled.

FIG. 5 is a fragmentary perspective view of the lower right hand corner of the oven door with parts broken away and others in cross-section to show the nature of the door guide sleeve which is adapted to slip over the door guide of the hinge mechanism of FIG. 4.

### DESCRIPTION OF THE PREFERRED EMBODIMENT

Turning now to a consideration of the drawings, and in particular to FIG. 1, there is shown for illustrative purposes an electric range 10 having a top cooking surface 11 with a plurality of surface heating elements 12.

The cooking surface **11** is supported on a hollow range body or cabinet structure **13** in which is furnished an oven cooking cavity (not shown) that is formed by a box-like oven liner (not shown) and a front-opening drop door **15**. A cooking utensil storage drawer **17** is located beneath the oven. The present invention relates to a hinging system for the oven door **15**. While the invention is shown as incorporated in a domestic electric oven, it will be recognized by those skilled in this art that the invention is not limited to use in such an appliance but may be used with other appliances or cooking apparatus whether it is gas or commercial equipment without departing from the scope of the present invention.

Turning now to a consideration of FIG. 3, the range cabinet **13** has a front wall or door frame **20** to which is mounted a hinge mechanism **22** of the present invention. Of course, there would be a pair of hinge mechanisms for supporting the oven door **15**, but only one such mechanism will be described for the sake of simplicity since both hinge mechanisms are identical in nature and action.

The hinge mechanism **22** comprises an L-shaped support bracket **24** that is mainly located out of sight behind the front door frame **20**. This bracket has a generally vertical leg **26** and a horizontal arm **28**. The arm **28** protrudes outwardly through a narrow slot **29**. On the free end of this arm **28** is pivotally supported a door guide **30** by means of a hinge pin **32** that extends through both members. The door guide **30** is a male member that is adapted to fit into a door guide sleeve **34** that is mounted within the oven door **15**. The position of this door guide **30** is governed by a hinge lever **36** which is pivotally connected at one end to the door guide **30** by means of pivot pin **38**, and is joined to a counterbalance spring **58** at its free end **39**.

A roller assembly **40** is mounted above the support bracket **24** by means of rivets or fasteners **42** so that the support bracket **24** and the roller assembly **40** are in effect one member. The nature of this roller assembly **40** may best be understood by referring to the perspective view, FIG. 4, of the hinge mechanism **22**. The roller assembly **40** is in effect an elongated channel-like member that is arranged in a vertical position and has a pair of parallel sides **44** connected together at the front side by a spacer **46** at the front. This spacer is substantially cut away at the center and at the bottom as at **48** and **50** respectively. The slotted portion **48** is adapted to receive the hinge lever **36** therethrough, while the cut-away portion **50** allows the bottom portion of the roller assembly **22** to be collapsed against the arm **28** of the support bracket **24** for making strong connection therewith by means of the two rivets **42**.

The intermediate portion of the roller assembly **40** includes a ball bearing, double flanged roller **54** that is adapted to cooperate with the lower contoured edge **56** of the hinge lever **36**. As mentioned previously, the free end **39** of the hinge lever **36** is provided with a tension spring **58** which is hooked thereto. The other end of the spring **58** is fastened to a fixed portion of the range cabinet **13** adjacent the base of the cabinet near the front thereof so that this spring could be replaced or adjusted by a serviceman if necessary by first removing the utensil storage drawer **17** for gaining access thereto. The free end **39** of the hinge lever **36** also includes a hook formation for engaging the roller **54** when the door is in its fully open horizontal position.

Next to be discussed with reference to FIGS. 4 and 5 is the anti-wobble feature that is designed into the door guide **30** and door guide sleeve **34** in the oven door **15**. The door guide **30** is also of elongated channel construction where the channel is pinched together at the bottom end **58** over the arm **28** of the support bracket **24** for receiving the hinge pin **32** therethrough. The door guide **30** is also collapsed near the center as at **60** in the vicinity of the pivot pin **38** that connects the hinge lever **36** to the door guide.

Looking above at the fragmentary perspective view of FIG. 5, the oven door **15** has a front panel **62** and an inner panel **64**. The lower right hand corner of the door **15** is broken away to show the door guide sleeve **34**. This sleeve **34** is an elongated box-like formation of folded sheet metal design established on the lower end of a vertical channel member **66** that is attached to the inner surface of panel **64**. The inner door panel **64** includes an elongated vertical slot **68** for receiving the hinge lever **36** therethrough. This inner door panel **64** also includes a forwardly directed flange **70** while the front door panel **62** includes a rearwardly directed flange **72** which telescope with each other. Both of these flanges **70** and **72** are slotted as at **74** in the same plane as the slot **68** as an extension thereof for receiving the door guide **30** and the hinge lever **36**, as is clear from the fully assembled view of FIG. 2.

The door guide sleeve **34** includes a first vertical wall **76** that is parallel to the slot **68** and a second vertical wall **78** that is at right angles to the first wall **76** and is parallel to and opposing the slot **68**, as is best seen in FIG. 5. The bottom of the channel **66** includes a forwardly directed flange **80** that overlies, but is vertically spaced above, the flange **70** of the inner door panel **64** at the side of the slot **74**. This flange **80** includes a strip **82** on its free end which is folded up and extends across the slot **74** to overlie the bottom portion of the vertical wall **78** so that it can be attached by welding or the like to serve as a rigid reinforcement of the door guide sleeve. The lower end of the wall **76** is provided with a sidewardly directed flange **86** which extends lower than the flange **80**, and it is fastened to the flange **70** of the inner door panel **64** by welding or the like to also serve as a reinforcing means for the door guide sleeve **34**. The top of the vertical wall **76** is provided with a sidewardly directed flange **88** which serves as a top cover or stop that is engaged by the top edge **90** of the door guide **30** in order to carry the weight of the door, as is best seen in the assembled view of FIG. 2.

As is clear from FIG. 3, the door **15** may be considered as being lowered onto the door guide **30** and since the door guide sleeve **34** must freely slide over the door guide there must be a certain amount of clearance between the two parts to prevent binding or improper assembly. Remember that this door is not only installed on the hinges in the factory, but that it is designed to be removed and replaced frequently by the user of the oven for cleaning purposes. This clearance is usually enough for a slight front to back movement or wobble to occur between the door guide sleeve in the door relative to the door guide, and this movement is enough to be noticed and prove objectionable when the oven door is being opened and closed. Slight variations in the manufacturing process occur as time passes when the tools for forming these parts wear, and a very close mating relationship of the door guide sleeve and the door guide is not possible.

Turning now to a consideration of FIG. 5 and the vertical wall 78 of the door guide sleeve 34, it will be noticed that there is a small spring tab or lancing 94 which is inwardly directed. Similarly, there is a small spring tab or lancing 96 which is formed in the front side of the door guide 30 such that when the door 15 is lowered onto the door guide the spring tab 94 will bear against the front side of the door guide 30, while the second spring tab 96 will bear against the lower portion of the vertical wall 78 of the door guide sleeve 34, all as is clear from FIG. 2. These spring tabs create a perfect fit between the door guide 30 and the door guide sleeve 34 to prevent door wobble and give the user a feeling of strength, solidness and reliability of the door and door hinging system.

Turning to a consideration of FIG. 3, the contour of the lower edge 56 of the hinge lever 36 includes a broil detent position 100 that is adapted to embrace or be lodged upon the roller 54 when the door 15 is moved to a partially open position, at about an angle of 15° from the vertical closed position of FIG. 2. This broil detent 100 is capable of maintaining the door in this broil position for open door broiling within the oven for steaks, roasts and large cuts of meat. This detent or holding action will be maintained even after the oven door 15 has been slipped off the door guide 30.

A second detent is shown in FIG. 2 as the closed door detent 102 which serves to exert a small biasing force to the oven door 15 by means of the hinge lever 36 so as to hold the door firmly closed during the normal baking operations or during the time the oven is not in use.

Turning back to FIG. 3, the door guide 30 is shown in a dotted line position at an angle greater than 25° from the vertical position. This view is necessary to show how the door guide 30 is provided with a stop 106 which is adapted to be engaged by an end 108 of the hinge lever adjacent the pivot pin 38 such that at an angle greater than about 25° open, the hinge lever will be prevented from further pivotal action with respect to the door guide 30 and this tends to lift the hinge lever 36 off of the roller 54. By making the hinge lever 36 independent of the roller 54 after the door moves beyond the broil stop position is to improve the balancing action of the door so that the movement of the door does not become erratic. The best design technique is considered to be to have the door balanced so that it will open by itself slowly after an initial movement, rather than to have the oven door close automatically by itself. By taking the action of the roller 54 out of the balancing system nearly halfway through its travel the counterbalance spring 58 exerts a simple torque about the pivot pin 32 of the door having a simple movement arm that does not relate to the roller action at all.

Another feature of this invention is a slam-prevention stop 112 formed on the lower edge 56 of the hinge lever 36 forwardly of the closed detent 102 such that in the event the oven door 15 is removed from the door guide 30 and for some reason a person were to bump the door guide and it were to cause the hinge lever 36 to roll out of the detent 100 and also through the detent 102 the stop would engage the side of the roller 54 and prevent further movement of the door guide towards its closed position and thereby positively prevent the door guide from striking the front frame 20 of the oven door cabinet 13. If the door guide were allowed to strike the front frame undoubtedly the porcelain enamel finish on

the front frame 20 would be damaged and cause an unsightly scar which would be difficult to hide from view.

Another important feature of this invention is the ability to adjust the position of the door in order to obtain the proper fit of the door with relation to the front frame 20 and its door opening in the front of the oven liner of the oven. Looking again at FIG. 3 the top portion of the roller assembly 40 is shown fastened to the front frame 20 by means of a fastening screw 115. This screw is provided with a soft felt washer 117 that underlies the head of the screw. The opening in the front frame that receives the screw 115 is oversized. Turning briefly to FIG. 4, there is a ball-like formation 119 formed in the spacer 46 of the roller assembly 40, and it is provided with a screw opening 121 for receiving the fastener 115. This combination of the resilient felt washer 117 and the ball formation 119 in the roller assembly allows a limited amount of relative movement of the roller assembly in its own plane with relation to the front frame 20.

Remember that the roller assembly 40 is integral with the support bracket 24 and they may be considered as one member. The lower projection of the vertical leg 26 of the support bracket is provided with an adjustable fastener and slot arrangement 123 such that the fastener may be adjusted to loosen the support bracket and allow it to be moved before the fastener is tightened again. This movement causes the movement of the roller assembly 40 about the pivot screw 115. Thus the horizontal arm 28 of the support bracket and hence the door is adjusted either toward or away from the front frame 20 of the oven.

Modifications of this invention will occur to those skilled in this art. Therefore, it is to be understood that this invention is not limited to the particular embodiments disclosed but that it is intended to cover all modifications which are within the true spirit and scope of this invention as claimed.

What is claimed as new and desired to be secured by Letters Patent of the United States is:

1. A vertical door frame forming a door opening, a door adapted to be hinged to the door frame and movable between a horizontal open position and a vertical closed position, a pair of hinge mechanisms mounted on the door frame, the said door being removably mounted upon the hinge mechanisms, each hinge mechanism comprising a support bracket, a door guide pivotally supported from the support bracket, a hinge lever pivotally connected to the door guide, and slot means in the door frame through which the support bracket and hinge lever extend, a door guide sleeve mounted in the door for receiving the said door guide, and slot means in the door for reception of the door guide and hinge lever, the said support bracket including a roller assembly above the bracket for cooperating with the said hinge lever, and counterbalance spring means fixed at one end and connected at the other end to the hinge lever; the invention comprising anti-wobble resilient means between the door guide and door guide sleeve at both the top and bottom thereof to cause a tight fit between these two members and retard wobble action of the door on the hinge mechanisms in the front to back direction of pivotal movement of the door the said anti-wobble resilient means comprises an inwardly directed spring tab on the door guide sleeve adjacent the top thereof and a vertically

offset outwardly directed spring tab on the door guide adjacent the bottom thereof so that the anti-wobble means serves to take up the clearance between the two members.

2. An appliance comprising an outer cabinet with a front-opening access door, a front frame forming a door opening, and hinge means connecting the door to the cabinet so the door may move between a vertical closed position and a horizontal open position, the hinge means comprising a pair of hinge mechanisms, the door being removably mounted upon the hinge mechanisms, each hinge mechanism comprising a support bracket, a door guide pivotally supported from the support bracket, a hinge lever pivotally connected to the door guide and a door counterbalance spring fixed at one end within the cabinet and joined at its other end to the hinge lever, a door guide sleeve mounted within the door for receiving the said door guide, the said support bracket including a roller assembly having a roller on which the lower edge of the hinge lever is adapted to slide, said lower edge having a first intermediate de-

tent position, and a second door-closed detent position, and a slam-prevention stop adjacent the pivotal connection of the hinge lever to the door guide that is adapted to engage the front side of the said roller in the event the door has been removed from the pair of hinge mechanisms and the hinge lever begins to slide out of control over the said roller so that the door guide may not strike the front frame, the top portion of the roller assembly having a hinged connection to the door frame, while the bottom portion of the support bracket is provided with an adjustable fastener and slot arrangement for allowing the adjustment of the position of the door relative to the door frame, the said hinge connection at the top portion of the roller assembly comprising a front-applied fastener and resilient washer combination in the front frame of the appliance cabinet and an apertured rounded pad on the roller assembly for receiving the fastener to allow for limited relative movement of the roller assembly in the plane of the roller assembly.

\* \* \* \* \*

25

30

35

40

45

50

55

60

65