

F. L. BENJAMIN.
FLAX PULLER.

No. 521,927.

Patented June 26, 1894.

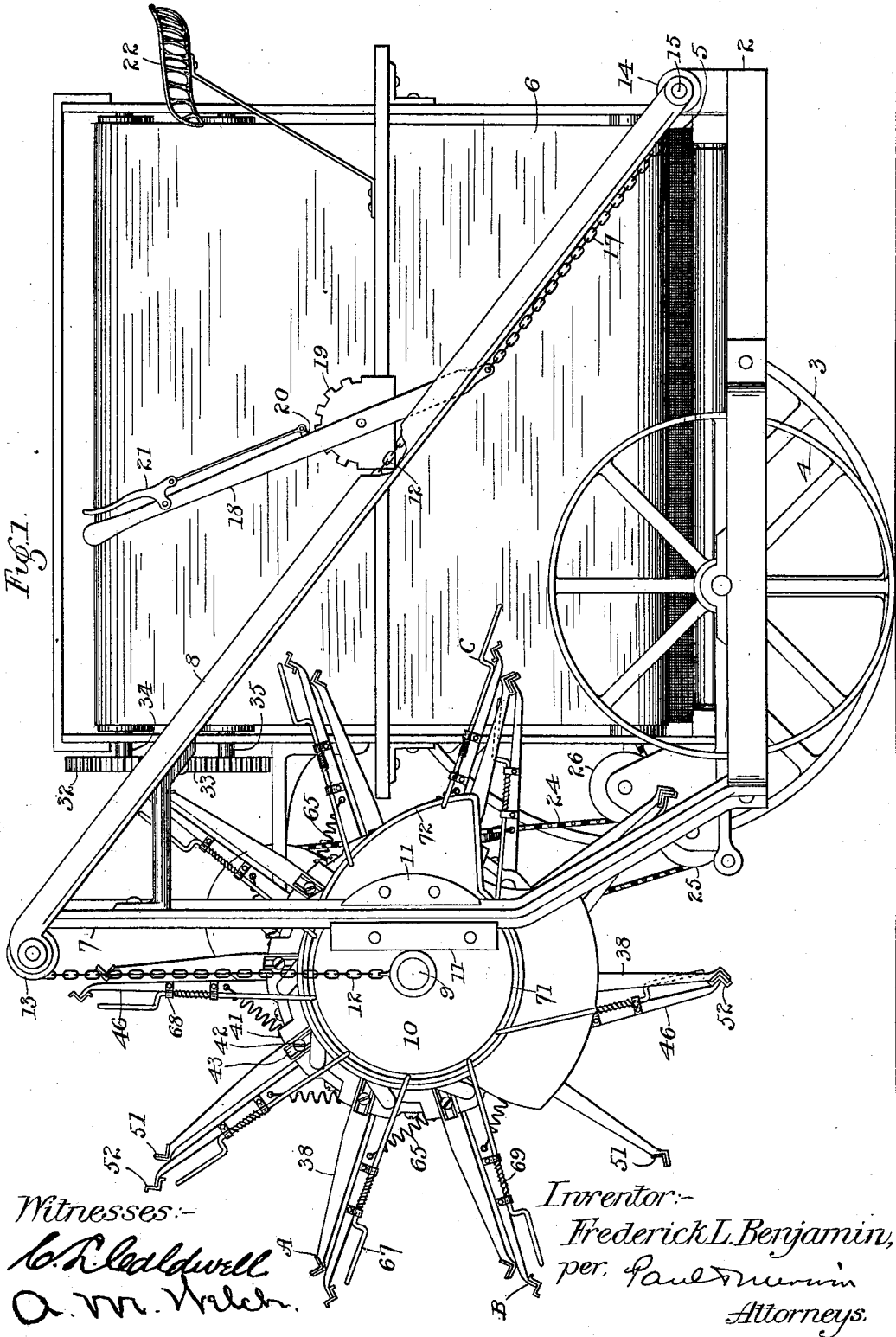

Fig. 1.

Witnesses:-
A. R. Caldwell
A. M. Welch

Inventor:-
Frederick L. Benjamin,
per. *Paul Durwin*
Attorneys.

(No Model.)

3 Sheets—Sheet 2.

F. L. BENJAMIN.
FLAX PULLER.

No. 521,927.

Patented June 26, 1894.

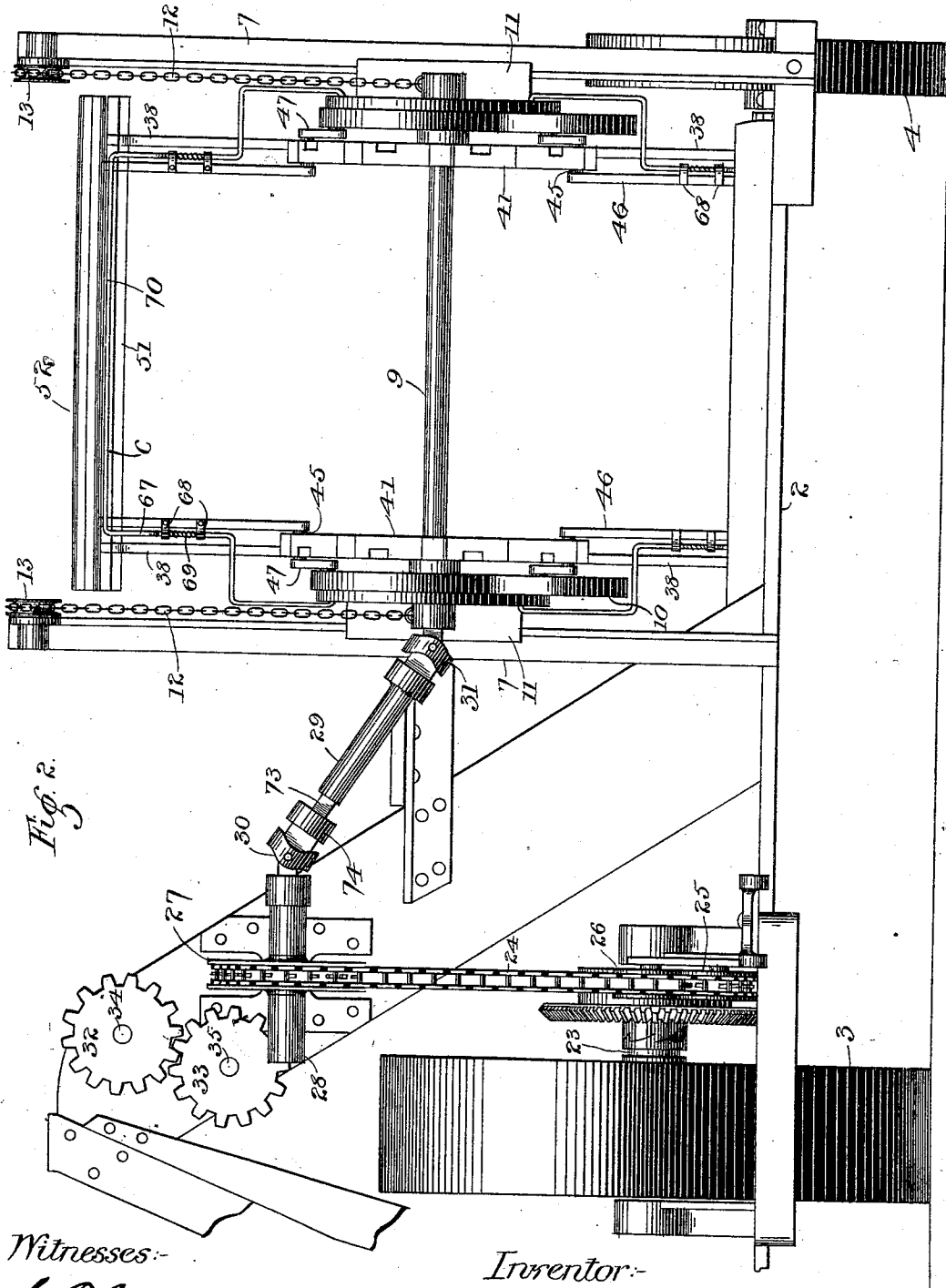

Witnesses:
L. R. Caldwell.
A. M. Welch.

Inventor:
Frederick L. Benjamin,
per. Paul & Meritt
Attorneys.

F. L. BENJAMIN.
FLAX PULLER.

No. 521,927.

Patented June 26, 1894.

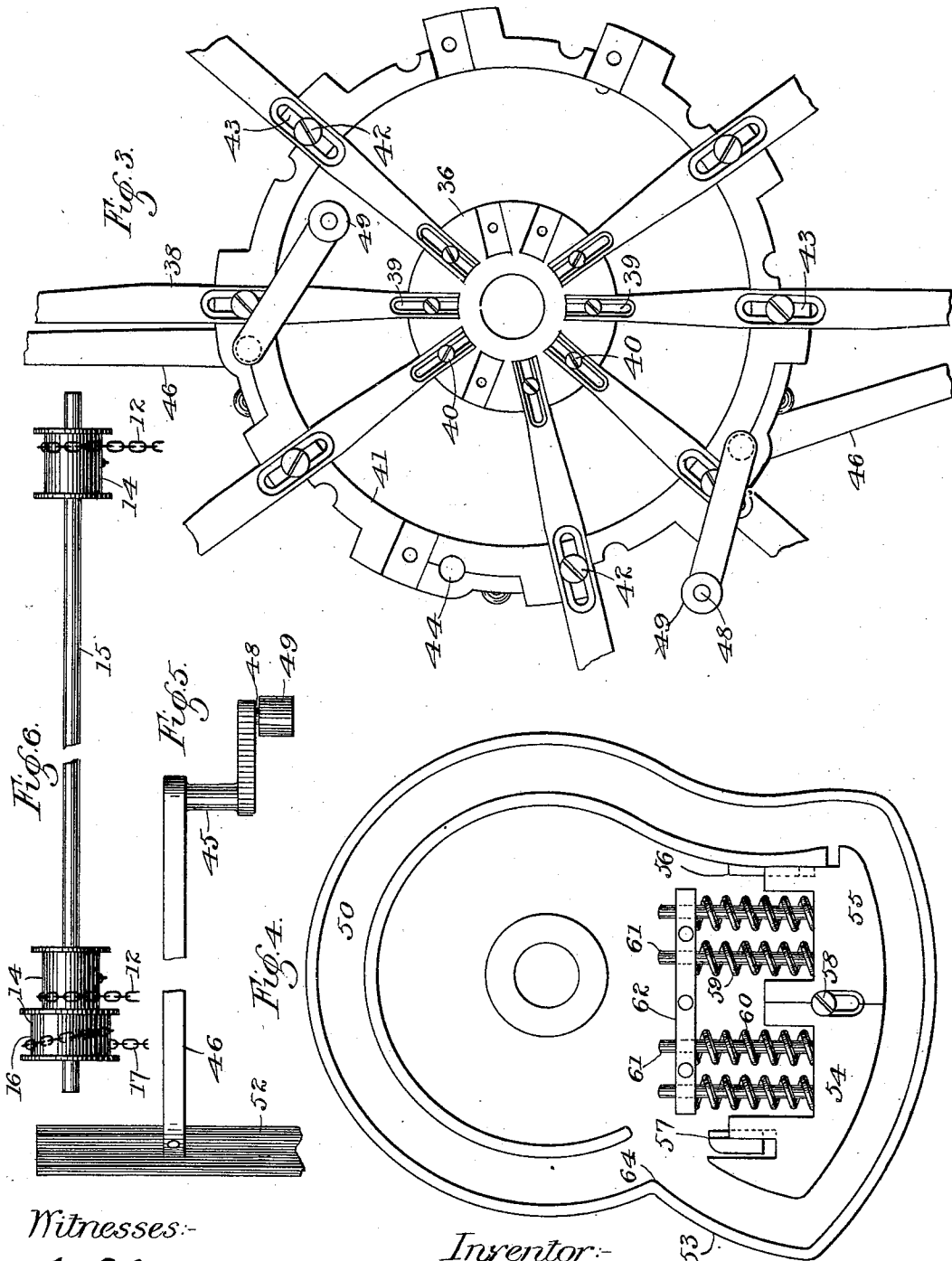

Witnesses:-

W. R. Caldwell
A. W. Welch

Inventor:-

Frederick L. Benjamin,
per. *Paul & Merwin*
Attorneys.

UNITED STATES PATENT OFFICE.

FREDERICK L. BENJAMIN, OF ST. PAUL, MINNESOTA, ASSIGNOR, BY MESNE ASSIGNMENTS, TO LUCIUS P. ORDWAY, OF SAME PLACE.

FLAX-PULLER.

SPECIFICATION forming part of Letters Patent No. 521,927, dated June 26, 1894.

Application filed November 12, 1891. Serial No. 411,662. (No model.)

To all whom it may concern:

Be it known that I, FREDERICK L. BENJAMIN, of St. Paul, Ramsey county, Minnesota, have invented certain Improvements in Flax-Pullers, of which the following is a specification.

My invention relates to flax pulling machines, especially that type in which the flax is pulled from the ground by means of a reel having clamping wings adapted to engage the tops of the flax as driven by the forward movement of the machine, and to pull it from the ground and carry it backward and deposit it upon the carrier of the machine; and consists in an improved construction of the clamping members or wings of the reel and means for operating the same, and in means for automatically thrusting the flax out of the clamps when released by the opening of the clamps; and also means for raising and lowering the reel to adjust it to different heights of flax.

My invention further consists in the construction and combination hereinafter described and particularly pointed out in the claims.

In the accompanying drawings forming part of this specification, Figure 1 is a side elevation of my improved flax puller showing the means for raising and lowering the reel, and the relative arrangement of the wings upon the reel, and the means for forcing the flax out of the clamps when their grip is released. Fig. 2 is a partial front elevation of the same, showing the connections for driving the reel from the drive wheel of the machine. Fig. 3 is a detail, partial end elevation of the reel, the cam being removed, showing the method of adjustably securing the fixed wings, and the arrangement of the hinged wings. Fig. 4 is a detail of the cam for operating the hinged wings. Fig. 5 is a detail of one of the arms of one of the hinged wings, and a portion of the connecting angle bar, and Fig. 6 is a detail of the winding drum shaft for raising and lowering the reel.

In the drawings, 2 represents the frame of the machine, which is of the type of an ordinary harvester, supported upon the drive wheel 3, and the carrying wheel 4, and provided with the carriers or aprons 5 and 6.

At the front of the machine are arranged

the standards 7, connected at the bottom to the frame 2, and having the braces 8. The reel shaft 9 is journaled at each end in the cam plates 10, which are fitted with guides 11 for engaging and supporting the same upon the standards 7, the whole being suspended by means of chains or cables 12 connected to said bearings, and running over sheaves 13 journaled at the top of the standards 7, thence downward, and over the drums or sheaves 14 at the bottom of the braces 8. The sheaves 14 are secured rigidly upon the shaft 15, also provided with the drum 16, upon which is secured and adapted to be wound the chain or cable 17 in a reverse direction from the windings of the chains 12 upon the sheaves 14. The chain 17 is connected to the fulcrum end of the lever 18, which is pivoted to the frame of the machine, and is preferably provided with a segmental gear or ratchet 19, with which a dog 20 controlled by the auxiliary handle 21 is adapted to engage to lock the lever in adjusted positions; the lever being placed in convenient position to the operator when in the seat 22.

The reel shaft 9 is driven from the shaft 23 of the drive wheel 3, by means of the link belt 24 running over the sprockets 25 and 26, thence over the sprocket 27 upon the shaft 28. This shaft 28 is connected to the reel shaft by means of the intermediate or coupling shaft 29, having universal joint connections 30 and 31 with said shafts.

32 and 33 are intermeshing gears upon the carrier shafts 34 and 35, for driving carriers or belts, as in the ordinary construction of harvester, but form no part of my present invention.

Secured to each end of the shaft 9 next the cams 10, are the rings or disks 36 to which are adjustably secured the arms 38 of the fixed wings A of the reel. The adjustment is made by means of a slot 39 through which passes the securing screw or bolt 40, into the disk or ring, so that the length of the arm or wings may be radially adjusted. The wings are secured to each other and stayed by means of the ring 41 concentric with the shaft, to which the wing arms are secured by means of the screws 42 passing through the slots 43 in the arms. The rings 41 are also provided with

suitable bearings 44 to receive the journals 45 of the arms 46, of the hinged wings B. To the outer end of the journals 45 are connected the cranks 47, the crank pins 48 of which are provided preferably with anti-friction rolls 49, running in the groove or guide 50 of the cam or eccentric 10. The cross bars 51 of the fixed wings, are made of V shaped angle iron to fit the angle irons of the fixed wings, and are preferably provided with reverse angles 52 to overlap and bear upon the edges of the angle irons 51, so as to increase their clamping power or grip.

The groove of the cam or eccentric 10 is such that each wing B is held against the adjacent rear fixed wing, through the upper arc of rotation, but is turned on its hinge to close it against the adjacent forward fixed wing, with the angle irons of the wings in engagement with each other, during the lower arc of rotation, the relative positions of the wings being clearly indicated in Fig. 1 at different points in the path of rotation of the reel.

In order to hold the hinged wings against the fixed wings with elastic pressure, and to adapt them to different quantities of flax, I arrange in the cam, spring controlled sliding blocks 54 and 55 which serve as the inner wall of the groove 50, through the arc of rotation of the reel when the clamps are closed. These blocks are held preferably by suitable guides 56 and 57, and the screw 58 from displacement, and are actuated or thrust forward by means of springs 59 and 60, surrounding the pins or shafts 61, which slide in the guide 62. The hinged wings are journaled preferably much closer to the fixed wings in their rear, than to those in front, so as to get a better clamping action when closed against the forward wings, and so that when open, the hinged wings shall project beyond the fixed wings, as shown in Fig. 1.

In order to secure a quick closing action of the hinged wings, I provide an inner angle 64 in the groove 50, at the point where the hinged wing is to close, the inner wall of the groove at this point being preferably removed, as shown in Fig. 4. In order to carry the crank around the angle 64 quickly, so that it will be held in the groove between the block 54 and the outer wall of the groove, I provide spiral springs 65 connecting the arms of the hinged wings with the arms of the fixed wings immediately forward, so that as soon as the crank pins of a hinged wing reach the angle, the spring acts to throw the wing forward and carry the crank pin along close to the outer wall 53 of the groove. The shape of the groove next the blocks 54 and 55 is an arc of a circle having its center at the axis of the shaft 9, so that the wings are clamped together with uniform pressure while passing through this arc, the length of the arc determining the distance through which the wings move in closed position. In order to throw the flax out of the clamp when it is released from the pressure by the open-

ing of the wings, I provide a clearer C in the form of a bail or sliding wing, the arms 67 of which are held in guides 68 upon the arms 70 of the hinged wings. These arms are provided with spiral springs 69 which tend to slide the bail outward upon the wing, so that its cross bar 70 projects some inches beyond the cross bar of the wing. The inner ends of the arms 67 are bent outward and inturned, as best shown in Fig. 2, the tips of the arms being arranged to slide in the eccentric groove 71, upon the outer face of the cam 10. This groove holds the bails through the greater part of the arc of rotation of the reel drawn inward, as shown clearly in Fig. 1, but at the point where the wings open, the outer wall 72 of the groove 71 is carried outward as shown, thus permitting the springs to act to carry the bail outward. The cross bar of the bail being arranged to pass close to the cross bar of the wing will strike against the flax which has been clamped between the wings, and throw it off and cause it to fall flat upon the carrier of the machine. With the continued rotation of the reel, the bail is drawn inward as the wall 72 approaches the axis of the reel. To adjust the length of the connecting shaft 29 to the varying heights of the reel, I prefer to form the shaft with a narrowed square neck 73 which slides freely in the corresponding socket in the part 74 connected to the universal joint 30.

Operation: The lever 18 is adjusted in position to support the reel at the desired height, according to the size of the flax to be harvested. The machine then being drawn forward, the reel is rotated by the described connections with the driving wheel. The hinged wings of the reel rest against the fixed wings in the reel until they have descended into the heads of the flax and the crank pins reach the angle 64 of the cam, when the springs 65 act to swing the hinged wings forward against the fixed wings the crank pins passing around in the grooves outside the blocks 54 and 55, and holding the hinged wings with spring pressure against the fixed wings, thus clamping the tops of the flax, and with the rotation of the reel pulling the plants from the ground and carrying them back over the carrier 5 upon the machine. The crank pins then successively pass around the end of the blocks 55, and approaching the center of the axis of the reel turn the hinged wings backward again, and away from the fixed wings, against which they have been clamped, releasing the flax. At the same instant the bails C are thrust outward by means of their springs, the cross bars 70 thrusting the flax heads off from the cross bar of the wing, and causing them to fall flat upon the carrier 5, whence they are delivered in the ordinary manner to the bundling shelf.

I claim—

1. In a device of the class described, the combination with the reel, of the fixed wings and the alternating hinged wings having in-

termeshing angle-iron cross bars, and means for clamping the same together through a predetermined arc of their rotation, substantially as described.

5 2. In a device of the class described, the combination with the rotating clamps, of meshing angle iron jaws for the clamp members, substantially as described.

10 3. In a device of the class described, the combination with the reel having fixed wings and alternating, clamping hinged wings, of the "V" shaped cross bars for said fixed wings, and the angle iron cross bars for the hinged wings adapted to mesh therewith in
15 the closing of the wings, substantially as described.

4. In a device of the class described, the combination of the fixed wings of the reel, having V shaped angle iron cross bars, the
20 hinged wings alternating with said fixed wings having angle iron cross bars adapted to fit to the cross bars of the fixed wings and overlap the edges thereof, and means for automatically opening and closing said wings
25 through predetermined arcs of their rotation, substantially as described.

5. In a device of the class described, having a reel provided with a series of fixed wings, and a series of alternating hinged wings, the
30 combination therewith of cranks upon said hinged wings, cams engaging said cranks and serving to turn said hinged wings to and from the adjacent fixed wings through predetermined arcs of their rotation, and spring controlled pressure blocks, serving as the walls
35 of the cams against which said cranks bear while said wings are clamped together, substantially as described.

6. The combination with the reel having
40 the series of fixed wings and the series of alternating hinged wings provided with cranks, of eccentric grooves engaging the pins of said cranks, and closing said hinged wings against the fixed wings through a predetermined arc
45 of rotation, sectional sliding inner walls for said grooves, and springs thrusting said sections outward so as to hold said hinged wings with elastic pressure against the fixed wings, substantially as described.

50 7. In a device of the class described, the combination with the reel having a series of clamps operative through a predetermined arc of its rotation, of spring actuated clearers working between the jaws of the clamps simultaneously with their opening movement,
55 substantially as described.

8. In a device of the class described, the combination with the pulling reel, having a

series of clamping wings, of clearers reciprocating between the clamp members, springs
60 for thrusting said clearers outward beyond the jaws of the clamps, and means for holding said clearers drawn inward against the tension of said springs, while said clamps are closed, substantially as described. 65

9. In a flax pulling reel, having a series of clamping wings, the combination therewith of a bar arranged between each pair of wings or clamp members, substantially parallel with
70 the cross bars of the wings, and automatic means for thrusting the same outward beyond said cross bars with the opening of the clamp, substantially as described.

10. In a flax pulling reel, the combination of the fixed wings, the alternate hinged wings,
75 means for closing the hinged wings against the fixed wings through a predetermined arc of their rotation, a sliding bail or wing intermediate of each of said fixed and hinged wings, means for normally holding it indrawn
80 from the cross bars of said wings, while the same are closed together, and means for automatically thrusting the bail outward beyond said cross bars, simultaneously with the opening of said wings, substantially as de-
85 scribed.

11. In a flax pulling reel, the combination with the clamping wings, of the sliding wing between the same, the cam guides engaging
90 said sliding wing, and the springs tending to thrust the same outward, substantially as described.

12. In a flax pulling reel, the combination with the clamping wings, of a clearer sliding
95 between each pair of clamps, means for normally holding it inward from the clamp jaws, and automatic means for thrusting it outward between said jaws simultaneously with their opening, substantially as described.

13. In a device of the class described, the
100 combination with the reel, its fixed wings, its intermediate hinged wings provided with cranks, and the eccentric guides engaging said cranks, of the clearers slidable upon said hinged wings to and from the axis of the reel,
105 the springs tending to thrust said clearers outward beyond the cross bars of said wings, and the eccentric guides engaging said clearers and holding them against the tension of said springs, substantially as described. 110

In testimony whereof I have hereunto set my hand this 3d day of November, 1891.

FREDERICK L. BENJAMIN.

In presence of—

T. D. MERWIN,

A. M. WELCH.