



(86) Date de dépôt PCT/PCT Filing Date: 2004/06/17  
 (87) Date publication PCT/PCT Publication Date: 2004/12/29  
 (85) Entrée phase nationale/National Entry: 2005/12/08  
 (86) N° demande PCT/PCT Application No.: IB 2004/002024  
 (87) N° publication PCT/PCT Publication No.: 2004/112869  
 (30) Priorité/Priority: 2003/06/25 (03 07643) FR

(51) Cl.Int./Int.Cl. *A61M 1/16* (2006.01)  
 (71) Demandeur/Applicant:  
GAMBRO LUNDIA AB, SE  
 (72) Inventeur/Inventor:  
CHEVALLET, JACQUES, FR  
 (74) Agent: ROBIC

(54) Titre : DISPOSITIF DE TRAITEMENT DE SANG PAR CIRCULATION EXTRACORPORELLE A VIDANGE  
AUTOMATIQUE DE LIQUIDE USE  
 (54) Title: BLOOD PROCESSING DEVICE USING EXTRA-CORPOREAL CIRCULATION AND AUTOMATIC SPENT  
FLUID DRAINAGE

1er Mode de réalisation

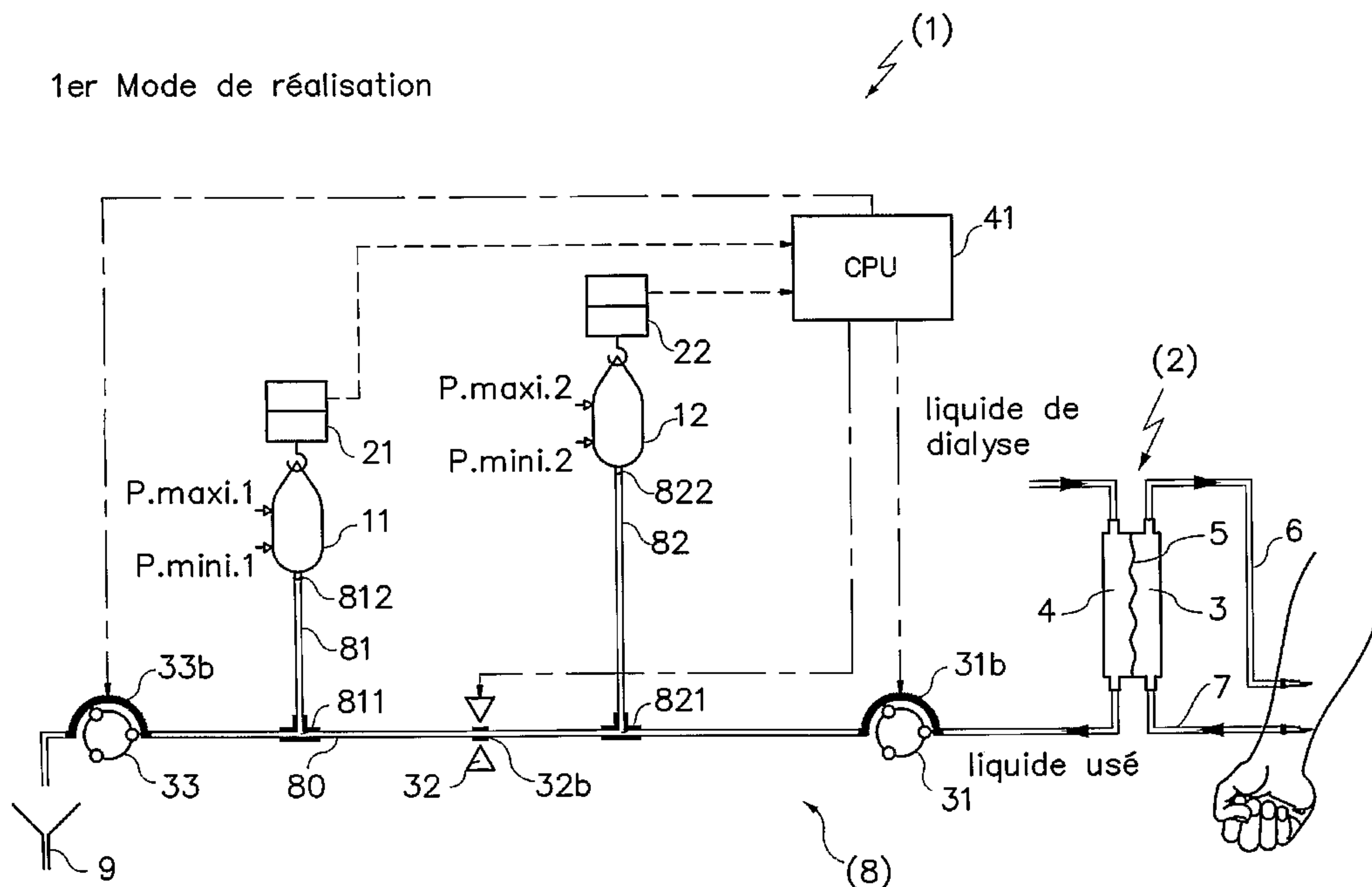

(57) Abrégé/Abstract:

The invention relates to a blood processing device using extra-corporeal circulation and comprising a filter (2) with a semipermeable membrane (5); a blood circuit (7, 3, 6); a dialysate circuit comprising the secondary filter chamber (4) and at least one drainage line (8) for a flow of spent fluid to be discharged from the filter into a drain (9); a first bag (11) in fluid communication with the drainage line; at least one first gravimetric weighing means (21) linked to the first bag, means for controlling the active fluid flow on the drainage line (31, 32, 33); a control unit (41) connected to the first gravimetric weighing means and the fluid flow control means; a second bag (12) in fluid communication with the drainage line, wherein the control unit can receive the weight signals from the first gravimetric weighing means and control the control means to fill one of the bags with fluid while the other bag is emptied of fluid, and vice versa. The invention further relates to a disposable drainage line for use in the processing device.

(12) DEMANDE INTERNATIONALE PUBLIÉE EN VERTU DU TRAITÉ DE COOPÉRATION  
EN MATIÈRE DE BREVETS (PCT)(19) Organisation Mondiale de la Propriété  
Intellectuelle  
Bureau international(43) Date de la publication internationale  
29 décembre 2004 (29.12.2004)

PCT

(10) Numéro de publication internationale  
**WO 2004/112869 A1**

- (51) Classification internationale des brevets<sup>7</sup> : A61M 1/16
- (21) Numéro de la demande internationale : PCT/IB2004/002024
- (22) Date de dépôt international : 17 juin 2004 (17.06.2004)
- (25) Langue de dépôt : français
- (26) Langue de publication : français
- (30) Données relatives à la priorité :  
03 07643 25 juin 2003 (25.06.2003) FR
- (71) Déposant (pour tous les États désignés sauf US) : **GAMBRO LUNDIA AB** [SE/SE]; Magistratsvägen 16, S-226 43 Lund (SE).
- (72) Inventeur; et
- (75) Inventeur/Déposant (pour US seulement) : **CHEVALLET, Jacques** [FR/FR]; 8, route de Ternay, F-69360 Serezin du Rhone (FR).
- (74) Mandataire : **SUTTO, Luca**; Gambro Dasco S.p.A., Intellectual Property Department, via Modenese, 66, I-41036 Medolla (IT).
- (81) États désignés (sauf indication contraire, pour tout titre de protection nationale disponible) : AE, AG, AL, AM, AT, AU, AZ, BA, BB, BG, BR, BW, BY, BZ, CA, CH, CN, CO, CR, CU, CZ, DE, DK, DM, DZ, EC, EE, EG, ES, FI, GB, GD, GE, GH, GM, HR, HU, ID, IL, IN, IS, JP, KE, KG, KP, KR, KZ, LC, LK, LR, LS, LT, LU, LV, MA, MD, MG, MK, MN, MW, MX, MZ, NA, NI, NO, NZ, OM, PG, PH,

[Suite sur la page suivante]

(54) Title: BLOOD PROCESSING DEVICE USING EXTRA-CORPOREAL CIRCULATION AND AUTOMATIC SPENT FLUID DRAINAGE

(54) Titre : DISPOSITIF DE TRAITEMENT DE SANG PAR CIRCULATION EXTRACORPORELLE A VIDANGE AUTOMATIQUE DE LIQUIDE USE

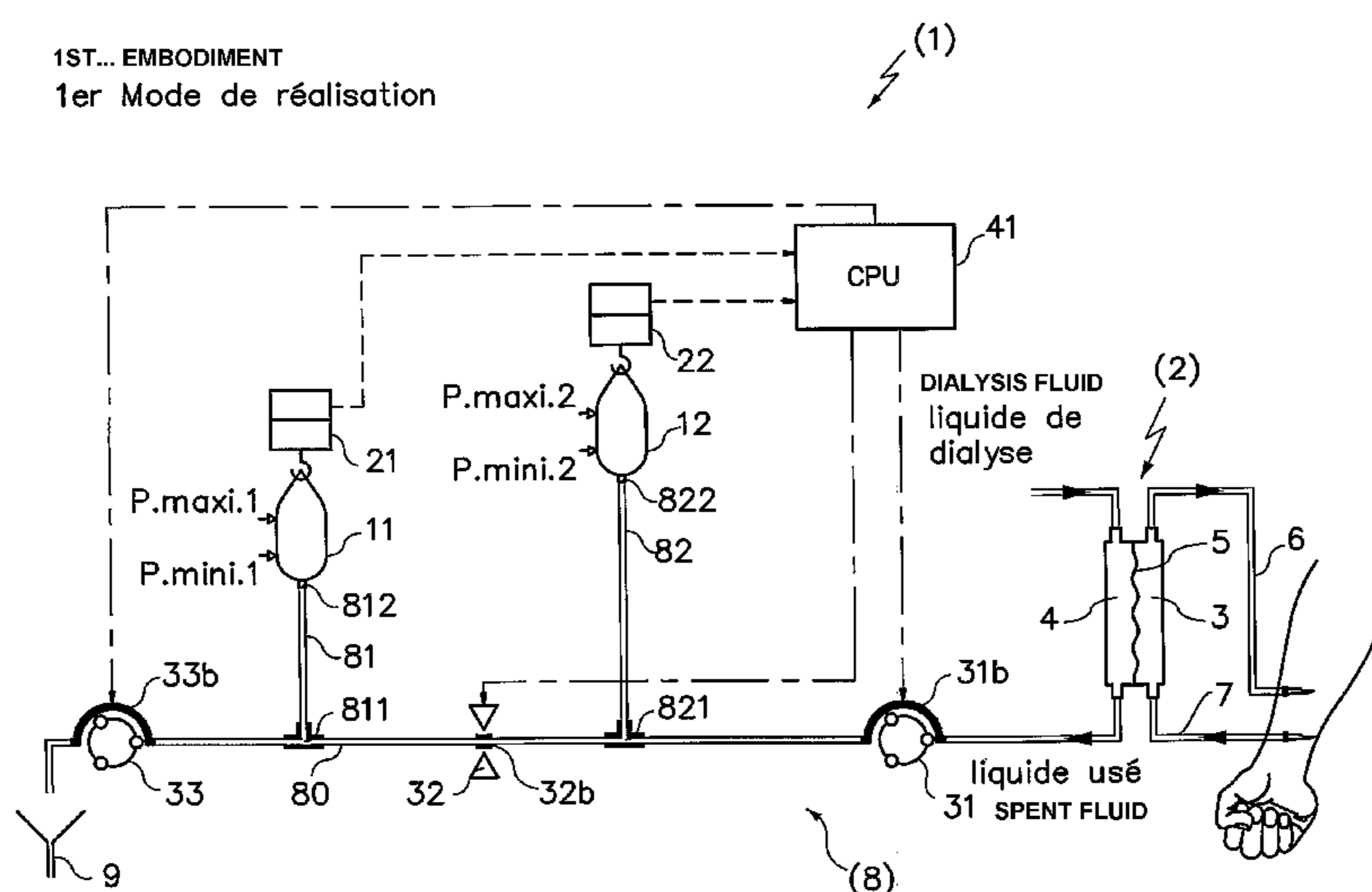

(57) **Abstract:** The invention relates to a blood processing device using extra-corporeal circulation and comprising a filter (2) with a semipermeable membrane (5); a blood circuit (7, 3, 6); a dialysate circuit comprising the secondary filter chamber (4) and at least one drainage line (8) for a flow of spent fluid to be discharged from the filter into a drain (9); a first bag (11) in fluid communication with the drainage line; at least one first gravimetric weighing means (21) linked to the first bag, means for controlling the active fluid flow on the drainage line (31, 32, 33); a control unit (41) connected to the first gravimetric weighing means and the fluid flow control means; a second bag (12) in fluid communication with the drainage line, wherein the control unit can receive the weight signals from the first gravimetric weighing means and control the control means to fill one of the bags with fluid while the other bag is emptied of fluid, and vice versa. The invention further relates to a disposable drainage line for use in the processing device.

(57) **Abrégé :** L'invention concerne un dispositif de traitement de sang par circulation extracorporelle comportant un filtre (2) avec une membrane semi-perméable (5); un circuit sang (7, 3, 6); un circuit dialysat comportant la chambre secondaire du filtre (4) et au moins une ligne de vidange (8) pour

[Suite sur la page suivante]

WO 2004/112869 A1

**WO 2004/112869 A1**

PL, PT, RO, RU, SC, SD, SE, SG, SK, SL, SY, TJ, TM, TN,  
TR, TT, TZ, UA, UG, US, UZ, VC, VN, YU, ZA, ZM, ZW.

SK, TR), OAPI (BF, BJ, CF, CG, CI, CM, GA, GN, GQ,  
GW, ML, MR, NE, SN, TD, TG).

(84) **États désignés** (*sauf indication contraire, pour tout titre de protection régionale disponible*) : ARIPO (BW, GH, GM, KE, LS, MW, MZ, NA, SD, SL, SZ, TZ, UG, ZM, ZW), eurasién (AM, AZ, BY, KG, KZ, MD, RU, TJ, TM), européen (AT, BE, BG, CH, CY, CZ, DE, DK, EE, ES, FI, FR, GB, GR, HU, IE, IT, LU, MC, NL, PL, PT, RO, SE, SI,

**Publiée :**

— avec rapport de recherche internationale

*En ce qui concerne les codes à deux lettres et autres abréviations, se référer aux "Notes explicatives relatives aux codes et abréviations" figurant au début de chaque numéro ordinaire de la Gazette du PCT.*

---

la circulation du liquide usé destiné à sortir du filtre et destiné à aller vers un égout (9); un premier sac (11) en communication de fluide avec la ligne de vidange ; au moins un premier moyen de pesage gravimétrique (21) associé au premier sac, des moyens de réglage de débit de fluide actifs sur la ligne de vidange (31, 32, 33); une unité de contrôle (41) reliée au premier moyen de pesage gravimétrique et aux moyens de réglage de débit de fluide ; un second sac (12) en communication de fluide avec la ligne de vidange, l'unité de contrôle étant capable de recevoir les signaux de poids du premier moyen de pesage gravimétrique et de commander les moyens de réglage pour charger de liquide un des sacs pendant que l'autre sac se décharge de liquide, et vice-versa. L'invention concerne également une ligne jetable de vidange pour l'utilisation dans un dispositif de traitement.

**“BLOOD PROCESSING DEVICE USING EXTRA-CORPOREAL CIRCULATION AND AUTOMATIC SPENT FLUID DRAINAGE”**

5 **Technical field of the invention**

The present invention relates to extracorporeal blood treatment, and more particularly to an innovative and improved device for treating blood in which waste is drained automatically.

10

**State of the prior art:**

15

Extracorporeal blood treatment means taking the blood from a patient, treating the blood outside the patient, and returning the treated blood to the patient. Extracorporeal blood treatment is typically used to extract undesirable matter or molecules from the patient's blood, and/or to add beneficial matter or molecules to the blood. Extracorporeal blood treatment is used with patients incapable of effectively eliminating matter from their blood, for example in the case of a patient who is suffering from temporary or permanent kidney failure. These and other patients may undergo extracorporeal blood treatment to add to or to eliminate matter from their blood, to maintain an acid-base balance or to eliminate excess body fluids, for instance.

20

25

Extracorporeal blood treatment is typically performed by sampling the patient's blood in a continuous flow, by introducing the blood into a primary chamber of a filter in which the blood goes through a semi-permeable membrane. The semi-permeable membrane selectively lets the unwanted matter contained in the blood pass through the membrane, from the

primary chamber to the secondary chamber, and also selectively lets the beneficial matter contained in the liquid going into the secondary chamber pass through the membrane to the blood going into the primary chamber, according to the type of treatment.

5

A number of extracorporeal blood treatments can be performed by the same machine. In ultrafiltration (UF) treatment, the unwanted matter is eliminated from the blood by convection through the membrane in the secondary chamber.

10

In hemofiltration (HF) treatment, the blood runs through the semi-permeable membrane as in UF, and the beneficial matter is added to the blood, typically by the introduction of a fluid into the blood, either before, or after its passage through the filter and before it is returned to the patient.

15

In hemodialysis (HD) treatment, a secondary fluid containing the beneficial matter is introduced into the filter's secondary chamber. The blood's unwanted matter crosses the semi-permeable membrane and penetrates into the secondary fluid, and the beneficial matter of the secondary fluid can cross the membrane and penetrate into the blood.

20

In hemodiafiltration (HDF) treatment, the blood and the secondary fluid exchange their matter as in HD, and further, matter is added to the blood, typically by introducing a fluid into the treated blood before it is returned to the patient as in HF, and the unwanted matter is also eliminated from the blood by convection.

25

In each treatment, the secondary fluid goes through the filter's secondary chamber and receives the blood's unwanted matter by means of the membrane. This liquid is then extracted from the filter: it is commonly called waste, and is sent to a drain or to a receptacle then intended to be discharged into a drain.

30

As described above, a patient may suffer from temporary or permanent kidney failure.

35

In the case of permanent kidney failure, the patient has to undergo regular sessions, for instance three times a week, of extracorporeal blood treatment with a relatively high blood extraction rate, i.e. between 200 and 500 ml/min. Generally, health care personnel can install the treatment device with online liquid preparation that can include online sterilization,

and can install an online drain.

In the area of temporary kidney failure, the patient has to be treated urgently and has to undergo continuous and long-term extracorporeal blood treatment with a relatively low blood extraction rate, i.e. between 100 and 200 ml/min. Net water extraction from the patient is limited because the emergency treated patient is in a critical state.

In this emergency treatment case, health care personnel have to act rapidly and thus do not have the time to install the treatment apparatus with online liquid preparation. Indeed, it is much faster to attach to the device a dialysis liquid and/or an infusion liquid already prepared and stored in a sterile single-use bag, and it is faster to attach an empty single-use bag to collect the waste.

A machine using this solution of sterile single-use bags is known. During the intensive kidney-failure treatment session, this extracorporeal treatment machine has to provide and control several flow rates:

- the infusion flow rate ( $D_{inf}$ ), if liquid infusion with beneficial matter is prescribed for the patient,
- the dialysis liquid flow rate ( $D_{dial}$ ) entering into the filter's secondary chamber for HF or HDF modes,
- the flow rate representing the patient's weight loss ( $D_{wloss}$ ), i.e. the quantity of liquid extracted and lost by the patient,
- the flow rate representing the waste coming from the filter ( $D_{waste}$ ).

25

The system represented by the patient and the blood treatment apparatus is a closed system. Thus the following equation may be deduced:

$$D_{waste} = D_{inf} + D_{dial} + D_{wloss} \quad (1)$$

Also, before the treatment session, the doctor may prescribe:

- the infusion flow rate  $D_{inf}$  to control the quantity of beneficial matter to be infused to the patient,
- the dialysis flow rate  $D_{dial}$  to control matter going through the filter,
- the patient's weight loss flow rate  $D_{wloss}$  to prevent any potential illness of the patient during the session.

35

Consequently the waste flow rate is calculated using the equation (1).

For this, the use of a sterile single-use bag that enables the waste to be received and collected was described above. This known use is illustrated in Figure 1. The bag 11 is connected to the end of the waste line 8 linked to the secondary chamber 4. This bag 11 is combined with a gravimetric weighing means 21 linked to a control unit 41. Thus, weight signals are transmitted to the control unit 41 that is capable of monitoring the weight changes of the bag linked to the waste flow rate through the waste line 8, and to control a pump 31 acting on the waste line.

However, the session can last several days and the single-use waste bag is filled well before the end of the session. This phenomenon is all the more pronounced during an intensive treatment. Indeed, one wishes both to exchange a large quantity of liquid in HF or HDF therapy, and to perform long-term treatments.

As soon as the bag reaches a set filling level, the doctor or nurse acts on the machine to temporarily stop the pumps acting on the waste line, on the dialysis liquid line and on the infusion line respectively, while the blood continues to circulate extracorporeally in the filter's primary chamber. Once the pumps are stopped, the user has to disconnect and unhook the filled waste bag, drain it and/or clear it to the drains network. Then the user attaches and connects a new empty single-use bag to the treatment device and restarts the pumps to return to the extracorporeal treatment with fluid circulation through the two chambers (3, 4) of the filter 2.

This bag replacement operation has disadvantages:

- on the one hand, it can last several minutes and extend the treatment time by several minutes whenever the bag is filled and needs changing,
- on the other hand, this bag changing operation is performed while the blood still flows in the blood circuit without being able to come into contact with a flowing dialysis liquid, so that the treatment quality is then lessened,
- also, this operation is performed by health care personnel who have to monitor several patients at the same time. A waiting time before action by the personnel can again be added to the treatment time,
- further, the regular changing of the drain bag during a session adds an economic cost to the treatment,
- finally, bags generally have a volume of about five liters, are heavy and relatively fragile objects to handle and contain waste that may be a source

of unwanted substances if the bag were inconveniently to be perforated while handling.

5 **Description of the invention:**

The present invention is described with particular reference to the intensive kidney failure treatment (also called acute kidney failure treatment), without thereby limiting the scope of the invention to this specific application.

10

The object of the invention is to provide an extracorporeal blood treatment device having the same functions as currently known devices and enabling the described problems to be solved.

15

The object of the invention is to provide a blood treatment device for automatic draining and for waste flow rate control, a single-use drain line intended to work together with such a device as well as a corresponding draining method.

20

The blood treatment device by extracorporeal circulation according to the invention comprises:

- a filter having a primary chamber and a secondary chamber separated by a semi-permeable membrane,
- a blood circuit having an arterial line intended to come from the patient, the filter's primary chamber and a venous line intended to return to the patient,
- a dialysate circuit comprising the filter's secondary chamber and at least one drain line for circulation of the waste intended to come from the filter and intended to go to a drain,
- a first bag in fluid communication with the drain line,
- at least one first gravimetric weighing means linked to the first bag,
- fluid flow rate adjustment means acting on the drain line,
- a control unit linked to the first gravimetric weighing means and to the fluid flow rate adjustment means,

35

characterized in that it comprises:

- a second bag in fluid communication with the drain line,
- and in that the control unit:
  - i. receives the weight signals from the first gravimetric weighing

means and,

- ii. controls the fluid flow rate adjustment means to load one of the bags with liquid while the other bag unloads liquid, and vice-versa.

5

The single-use line for use in the device according to the invention comprises:

- a drain line intended to connect the filter output to the drain,
- fluid flow rate adjustment means on the drain line,
- 10 - two bags each attached to the drain line and intended to be attached to the treatment apparatus,
- at least one first part of the drain line intended to work together with a peristaltic pump.

15 **Brief description of the drawings:**

Additional characteristics and advantages will appear with the detailed description of a preferred but not exclusive embodiment of an extracorporeal blood treatment device according to the invention. This  
20 description will be given below with reference to the annexed drawings, which are supplied for information purposes and are thus not limiting.

Four embodiments of the invention are described.

25 Figure 1 represents an extracorporeal blood treatment device according to the known state of the art.

Figure 2 represents a first embodiment of the device according to the invention.

30 Figure 3 represents a first operating stage of the first embodiment of the device according to the invention.

Figure 4 represents the second operating stage of the first embodiment of the device according to the invention.

Figure 5 represents the weight change of bags measured during the treatment session of the first embodiment.

35 Figure 6 represents a second embodiment of the device according to the invention.

Figure 7 represents the first operating stage of the second embodiment of the device according to the invention.

Figure 8 represents the second operating stage of the second embodiment of the device according to the invention.

Figure 9 represents a third embodiment of the device according to the invention.

5 Figure 10 represents the first operating stage of the third embodiment of the device according to the invention.

Figure 11 represents the second operating stage of the third embodiment of the device according to the invention.

10 Figure 12 represents a fourth embodiment of the device according to the invention.

Figure 13 represents the first operating stage of the fourth embodiment of the device according to the invention.

Figure 14 represents the second operating stage of the fourth embodiment of the device according to the invention.

15

#### **Detailed description of the embodiments of the invention:**

##### **Description common to all embodiments:**

20 With reference to the appended figures, globally 1 designates the extracorporeal blood treatment device. The blood treatment device 1 represented in Figures 1, 2, 6, 9 and 12 is in an operational configuration that enables it to perform a hemodialysis treatment. The other treatment configurations mentioned previously (ultrafiltration, hemofiltration and  
25 hemodiafiltration) are of course transposable to the embodiments of the invention.

The devices according to the various embodiments of the invention represented in Figures 2, 6, 9 and 12 contain one filter 2 having a primary  
30 chamber 3 and a secondary chamber 4 separated by a semi-permeable membrane 5; a blood circuit comprises an arterial line 6 intended to come from the patient, the filter's primary chamber 3 and a venous line 7 intended to be returned to the patient; a dialysate circuit comprises the filter's secondary chamber 4 and at least one drain line 8 intended for the  
35 waste flowing out from the filter 2 and intended to go to a drain 9, a first bag 11 with fluid connection to the drain line 8, at least one first means of gravimetric weighing 21 linked to the first bag 11, means of adjusting the fluid flow (31, 32, 33, 34) acting on the drain line 8; a control unit 41 is

linked to the first means of gravimetric weighing 21 and to the fluid flow adjustment means (31, 32, 33, 34). The devices according to the various embodiments of the invention comprise a second bag 12 with fluid communication to the drain line 8.

5 The control unit 41 is capable of receiving the weight signals from the first gravimetric weighing means and of controlling the fluid flow adjustment means (31, 32, 33, 34) to load one of the bags (11, 12) with liquid while the other bag (12, 11) unloads liquid, and vice-versa.

10 In all embodiments, the control unit 41 is also capable of calculating, from the weight signals received, the amount of liquid coming from the filter and entering the drain line 8.

15 More particularly and in all embodiments, the adjustment means comprise a first adjustment organ 31 acting upstream of the two bags (11, 12). Thus the first organ acts on the drain line, after the filter's secondary chamber outlet, upstream of the bags. Thus the control unit 41 will be programmed to control the first adjustment organ 31 to ensure the presence of a substantially continuous flow during the treatment. Indeed, the flow  
20 adjustment means are controlled so as not to have to stop the flow of waste coming from the filter. For better treatment quality, it can be ensured that the flow rate of the measured waste stays substantially constant or follows a required profile during the session.

25 In all embodiments, the adjustment means can comprise a second adjustment organ 32 acting between the two bags (11, 12).

In all embodiments, the adjustment means can comprise a second adjustment organ 33 acting between the two bags (11, 12).

30

Additional characteristics are possible for all embodiments.

Thus, the device can comprise a second gravimetric weighing means 22 linked to the second bag 12 and connected to the control unit 41. Indeed,  
35 the weight information supplied to the control unit by the first gravimetric weighing means has the job of knowing the weight of the single-use bag so as both to know the amount of liquid flowing, and to control the loading and unloading phase of the two bags by using two threshold values - maximum

and minimum – set by the user according to the bag's volume.

A second gravimetric weighing means can be linked to the second bag. The first job of the second gravimetric weighing means is to know the weight of the liquid flowing. It can also be used to control the cyclic loading and unloading process by using one or two threshold values of the second gravimetric weighing means, together with one or two threshold values of the first gravimetric weighing means. But if the use of the two threshold values is enough for the draining control, the four threshold values of the two scales can be used for preventive alarm purposes concerning a bag's abnormal state.

In all embodiments, the control unit 41 is capable of calculating the amount of fluid coming from the filter 2 and entering the drain line 8 from the weight signals received from the first gravimetric weighing means 21 and/or the second gravimetric weighing means 22.

For all embodiments, the control unit 41 is capable of activating a control procedure having two alternating phases.

In a first phase, the control unit controls the actual flow rate of the adjustment means (31, 32, 33, 34) according to the required flow rate profile and the weight information coming from at least the first gravimetric weighing means 21.

In a second phase, the control unit 41 controls the actual flow rate of the adjustment means (31, 32, 33, 34) according to the required flow rate profile and the weight information coming from the first and second gravimetric weighing means (21, 22).

The control unit 41 is also capable of activating a control procedure comprising two alternated phases with a control of the actual flow rate of the adjustment means (31, 32, 33, 34) during the first phase which is also performed according to the weight information of the second gravimetric weighing means 22. This alternative can be used in the third and fourth embodiments.

In all the embodiments, the control unit 41 is capable of receiving the weight information from the first gravimetric weighing means 21 and/or the second gravimetric weighing means 22, calculating the actual flow rate of

the fluid coming from the filter 2 and comparing it with a required set flow rate or with a flow rate profile required by the user, controlling the fluid's actual flow rate using the adjustment means to best approach the required flow rate profile of fluid coming from the filter 2.

5

In all the embodiments, the control unit is capable of receiving the weight information from the first gravimetric weighing means 21 and/or from the second gravimetric weighing means 22, independently determining the filling status of each bag, and controlling, from the filling status of each bag, an alternating and successive bag loading and unloading procedure.

10

In all the embodiments, the control unit is capable of receiving the weight information from the first gravimetric weighing means 21 and/or from the second gravimetric weighing means 22, detecting the maximum and minimum threshold values for each of the bags  $P_{1min}$ ,  $P_{1max}$ ,  $P_{2min}$ ,  $P_{2max}$ , and controlling, from the threshold values, a bag loading and unloading procedure according to the following steps:

15

- loading of one bag and unloading of the other bag,
- detection of a limit threshold,
- unloading of one bag and loading of the other bag,
- detection of another limit threshold.

20

**Description common to the first and second embodiments:**

In the first two embodiments of the invention, the drain line 8 can be defined with several components: a conduit 80 intended to link the filter 2 to the drain 9, a first branch 81 linking the first bag 11 to the conduit 80, a second branch 82 linking the second bag 12 to the conduit 80. The second branch 82 is connected to the conduit 80 upstream of the first branch 81. Also the first adjustment organ 31 and the second adjustment organ 32 act on the conduit 80, and not on the two branches.

30

Each of two branches can comprise a line with two respective terminal connections (811, 812, 821, 822), or a direct connection between the drain line (80) and an opening of a bag.

35

**Description of the first embodiment:**

In the first embodiment shown in Figure 2, the first 31 and third 33 adjustment organs are conveniently the peristaltic pumps, and the second

adjustment organ 32 is a valve.

In the first embodiment shown in Figure 2, the place in the bags' space has to be taken into account. It is known that the single-use bags used are  
5 attached to the machine with the opening of the bags placed conveniently towards the bottom to enable continuous flow of the fluid. One may have several bags especially a single-use bag collecting the waste, a single-use bag containing perfusion liquid, and a single-use bag comprising a dialysis liquid. These bags are often attached at the same level.

10 The invention uses gravity to facilitate the liquid's runoff without necessarily having to use an additional pump. Use is made of this in the first embodiment, but gravity could be used in the other embodiments by those skilled in the art using their knowledge and the description of the invention.

15 In this way, the first bag 11 is placed lower than the second bag 12 on the machine. Consequently, when waste is taken from the filter's secondary chamber and fluid flow is possible between the two bags, the first bag 11 will be loaded in priority in relation to the second bag, even if the second  
20 bag is placed upstream of the first bag in the fluid's circulation direction. Similarly, when the second bag is filled and the second is substantially empty, the second bag 12 will unload into the first bag 11 by gravity.

25 Figures 3 and 4 show the two operating phases of the drain cycle used by the apparatus and the fluid flow directions in the drain line, for the first embodiment.

Indeed, the control unit 41 is capable of controlling the adjustment organs (31, 32, 33) according to two alternating phases.

30 In the first phase, the control unit 41 controls the opening of the second adjustment organ 32 and the stopping of the third adjustment organ 33 to load the second bag 12 and unload the first bag 11 into the drain 9.

In the second phase, the control unit 41 controls the opening of the first adjustment organ 31 and the stopping of the third adjustment organ 33 to  
35 unload the second bag 12 and load the first bag 11.

It will be noted that the control to go from one phase to the other has to be performed conveniently and simultaneously in order to have a better

treatment quality, but a small time gap may be noticed between two actions, for instance between the opening of the second adjustment organ 32 and the stopping of the third adjustment organ 33. This is valid for any control of any adjustment means.

5

Figure 5 represents, for the first embodiment, the weight change of each bag according to the treatment time. These measurements were made experimentally and are reproducible.

10

The succession of the two phases during the draining cycle, preceded by a system-priming phase will now be explained, using the special case of Figure 5.

15

At the start of the session, the two bags are almost empty (a weight of 50 g is recorded) and a priming phase is implemented.

The control unit primes the first adjustment means 31, opens the second adjustment organ 32, and does not operate the third adjustment means 33. The first adjustment organ controls the waste flow in the drain line 8. From then, the liquid goes into the conduit 80.

20

Now the first bag 11 is downstream in relation to the second bag 12, but is attached to the device lower than the second bag. More especially, the top limit of the first bag is placed lower or at the same level as the bottom limit of the second bag. The second bag is loaded in priority in relation to the first bag.

25

Thus, it may be seen that the weight of the first bag 11 increases regularly in priority in relation to the weight of the second bag 12, which remains unchanged.

30

As soon as the first bag 11 reaches a maximum set weight  $P_{1max}$  (800 g for the test), the device will operate according to a first phase: The first adjustment organ 31 continues to operate, the second adjustment organ 32 is closed and the third adjustment organ operates to conduct the liquid to the drain.

35

From then the first bag 11 whose weight will have been memorized by the control unit, will unload into the drain. It may be seen that the weight of the first bag regularly decreases from 800 g to 200 g.

On the other hand, the second bag is loaded with the waste coming from the filter. A weight increase of the second bag 22 from 50 g to 330 g

approximately can be seen.

This phase is performed until a minimum weight threshold of the first bag  $P_{1\min}$  is reached (200 g), or a maximum weight threshold of the second bag  $P_{2\max}$  (330 g) is reached, or the first of the two above-mentioned thresholds  
5 is reached.

When such a threshold is detected, the control unit controls the entry into the second phase.

The unit 41 controls the opening of the second adjustment organ 32 and  
10 the stopping of operation of the third adjustment organ 33. Thus, the second almost full bag, whose weight information can be memorized by the control unit, unloads into the first almost empty bag. It can be seen that the first bag fills not only with the liquid contained in the second bag 22 but also with the liquid directly coming from the filter. That is why an inflection  
15 of the line representing the regular weight increase during the second phase can be seen: the second bag is almost emptied at this moment and the loading of the first bag will be performed less fast (50 g).

The first and second phase will alternate in this way until the end of the  
20 session.

The size of each of the bags, the size of the single-use lines is set by the user before the session. In the test carried out with the first embodiment, the second bag had a volume of about 500 g while the first bag had a  
25 bigger volume, about 1 kg; the lines have the same size. Naturally the flow rates adopted during the session match the size of the bags and the line and are such that the first bag 11 reaches a set minimum weight before the second bag 12 reaches a set maximum weight. In the illustrated test, the draining flow rate is 300 ml/min and the flow rate through the first  
30 adjustment organ is 150 ml/min.

#### **Description of the second embodiment:**

A second embodiment is shown in Figure 6 and the two operating phases are shown in Figures 7 and 8.  
35

In the second embodiment, the adjustment means can comprise a fourth adjustment organ 34 acting on the first branch 81 between the two connections (811, 812).

This fourth adjustment organ 34 can comprise indifferently a pump, more particularly a peristaltic pump, a valve, more particularly a two-way clamp or a valve with adjustable opening.

- 5 More particularly in the second embodiment, the first and fourth adjustment organs (31, 34) can be peristaltic pumps and the second and third adjustment organs (32, 33) can be valves.

10 In the second embodiment, the control unit 41 is capable of controlling the flow rate adjustment means (31, 32, 33) according to two alternating phases.

In first phase, the control unit 41 controls the closing of the second adjustment organ 32, the opening of the third adjustment organ 33, the activation of the fourth adjustment organ 34 in the bag-to-conduit direction.

15 In the second phase, the control unit 41 controls the opening of the second adjustment organ 32, the closing of the third adjustment organ 33, and the activation of the fourth adjustment organ 34 in the conduit-to-bag direction.

**Description common to the third and fourth embodiments:**

20 The invention also comprises a third and fourth embodiment shown respectively in Figures 9 and 12 and whose two operating phases are shown respectively in Figures 10 and 11 as well as 13 and 14.

In these two embodiments, the second adjustment organ 32 comprises a hydraulic system having six ports (51, 52, 53, 54, 55, 56) distributed as follows:

- 25
- a) a first input port 51 intended to be in fluid communication with the input portion of the drain line 8 intended to be linked to the filter,
  - b) a second input port 52 intended to be in fluid communication with the output portion of the drain line 8 intended to be linked to the drain,
  - 30 c) a third input port 53 and a fourth output port 54 each intended to be in fluid communication with the first bag 11,
  - d) a fifth input port 55 and a sixth output port 56 each intended to be in fluid communication with the second bag 12,

35 **Description of the third embodiment:**

In the third embodiment, shown in Figure 9, the hydraulic system of the second adjustment organ 32 comprises two parts.

The first part comprises a first line 57 intended to put the first input port 51

into fluid communication with each of the two output ports (54 and 56) intended to communicate with each bag and two clamps (322, 324) placed respectively on each portion of the first line 57 connected to said two output ports (54 and 56).

- 5 The second part comprises a second line 58 intended to put the second output port 52 into fluid communication with each of the two input ports (53 and 55) intended to communicate with each bag, two other clamps (321, 323) placed respectively on each portion of the second line 58 connected to said two input ports (53 and 55).

10

**Description of the fourth embodiment:**

In the fourth embodiment, shown in Figure 12, the structure of the hydraulic system of the second adjustment organ 32 is different, even if the operation is the same.

15

Indeed, the second adjustment means 32 comprises two parts.

- 20 The first part comprises a first line 57 intended to put the first input port 51 into fluid communication with each of two output ports (53, 55) intended to communicate with each bag and a first three-way clamp 325 capable of having two alternated positions. The first position is putting the first input port 51 into fluid communication with the third output port 53 at the first bag 11. The second position is putting the first input port 51 into fluid communication with the fifth output port 55 at the second bag 12.

25

- The second part comprises a second line 58 intended to put the second output port 52 into fluid communication with each of the two input ports (54, 56) intended to communicate with each bag and a second three-way clamp 326 capable of having two following alternated positions. A first position is putting the second output port 52 into fluid communication with the sixth input port 56, at the second bag 12. The second position is putting the second output port 52 into fluid communication with the fourth input port 54, at the first bag 11.

30

- 35 And, for the third and fourth embodiments, the alternating operating mode of loading and unloading is the same. Indeed, the control unit 41 simultaneously controls the clamps (321, 323, 323, 324, 325, 326) of the second adjustment organ 32 so that the two phases are alternated during

the operation.

In the first phase, the second bag 12 is loaded with liquid while the first bag 11 unloads to the drain 9.

5 In the second phase, the first bag 11 is loaded with liquid while the second bag 12 unloads to the drain 9.

It should be noticed that during the two phases, the third adjustment organ (33) ensures a substantially continuous flow rate, i.e. the waste is sent to the drain continuously.

10

The invention also relates to a single-use line for use in the device according to the invention.

15 In all embodiments, this single-use line comprises at least two bags and 4 line parts, including:

- a first line part intended to conduct the liquid from the input of the single-use line (80) towards one of the two bags (11,12);
- a second line part intended to conduct liquid from said bag towards the output of the single-use line (80);
- 20 - a third line part intended to conduct the liquid from the input of the single-use line (80) towards the other bag (12, 11);
- a fourth line part intended to conduct liquid stored in the other bag (12, 11) towards the output of the single-use line (80).

25 For the first and second embodiments described, the first and third parts share a common section linking the two bags.

Indeed, in the first and second embodiments: the first line part is comprised of a part of conduit 80 from the line input 80 up to the second  
30 connection 82 or 821 and by the second section or connection 82. The second line part is comprised of the section or connection 82 and by a part of conduit 80 between the connection 821 or 82 and the line output to the drain. The third line part is comprised of a part of conduit 80 from the line input up to the first connection 81 or 811 and by the first branch or  
35 connection 81. The fourth line part is comprised of the first connection of branch 82 and by a part of conduit 80 between the first connection or branch 81 or 811 and the line output.

In all the embodiments, the single-use line comprises a drain line 80 intended to connect the filter's output 2 to the drain 9, two bags (11, 12) each connected to the drain line 8 and intended to be attached to the treatment apparatus 1, and at least two parts (31b, 33b) of the drain line 8 intended to work together with the first adjustment organ 31 and the third adjustment organ 33 respectively.

In the first and second embodiments, the single-use line comprises a conduit 80 and at least two connections (81, 82) on the conduit 80.

In the first embodiment, the single-use line comprises another part 32b of the conduit 80 placed between the two connections and intended to work together with the second adjustment organ 32.

In the second embodiment, the single-use line comprises a fourth part (34b) placed on the first branch (81) and intended to work together with the fourth adjustment organ (34).

In the third embodiment, the single-use line comprises an input portion of the line, a drain line 8 and an output portion of the line.

The drain line 8 comprises a first channeling of line 57 intended to put the input portion of the drain line and a port to each bag into fluid communication, the first line being T-shaped, and comprises a second channeling of line 58 intended to put the output portion of the drain line and a second port to each bag into fluid communication, the second line being T-shaped.

In the fourth embodiment, the single-use line comprises an input portion of the line, a drain line 8 and an output portion of the line.

The drain line 8 comprises a first channeling 57 intended to put the input portion of the drain line and a port to each bag into fluid communication, the first channeling comprising a three-way valve with two inputs and one output for the selective connection of the output with one of the two outputs.

The drain line 8 also comprises a second channeling 58 intended to put the output portion of the drain line and a second port to each bag into fluid communication, the second channeling comprising a three-way valve with two inputs and one output for the selective connection of the output with one of the two outputs.

Such a single-use line can be placed before the start of the session on the extracorporeal treatment device. At the end of the session, this line is disconnected, discarded and replaced by a new line for the next session.

5 The invention also relates to an automatic draining method of the drain line, corresponding to the device according to the invention.

The method comprises two successive alternating phases having the following steps: the continuous flow of a waste through a drain line at a filter output, the first phase, and the second phase successive to and  
10 alternating with the first phase.

The first phase comprises the loading of a first container (for instance, a bag) with the waste and the unloading of a second container (for instance, a bag), and the reaching of a first measured threshold weight. The second phase comprises the unloading of a first container of the waste to a drain  
15 and the loading of a second container with waste, and the reaching of a second measured threshold weight.

In other words, the automatic draining method can comprise two successive alternating phases:

- 20 - the first phase comprises the loading of a first bag (11, 12) with waste and the unloading of a second bag (12, 11) of waste into a drain at the output of the drain line, this phase being stopped as soon as at least one of the two bags (11, 12) reaches a first measured threshold weight.
- 25 - the second phase comprises the unloading of the first liquid bags (11, 12) into a drain at the output of the drain line and the loading of the second bag (12, 11) with waste liquid, this phase being stopped as soon as a second measured threshold weight is reached for the same bag and/or the other bag.

30 **Advantages of the invention:**

The many advantages obtained by the invention are as follows:

- 35 - a control of the flow rate of waste going through the drain line is known and controlled,
- session duration with the automatic draining device is less than a session duration without automatic draining,
- health care personnel no longer have to intervene to carry out the bag

- changing operation,
- the weight of waste extracted from the filter is known and controlled,
  - the results and qualities of the treatment used according to the state of the art are saved,
  - 5 - the safety level provided by the treatment device is maintained,
  - hydric balance is maintained,
  - treatment cost is reduced because two bags are used instead of several bags replaced successively,
  - the first bag linked to its first gravimetric weighing means and the output
  - 10 portion of the drain line and the drain can be placed not on the device, but placed in a device or a separate part of the treatment device to ensure perfect separation between the device and the patient and the draining: this strengthens the safety of the treatment.

**CLAIMS**

- 5       **1.** A blood treatment device by extracorporeal circulation (1) comprising:
- filter (2) having a primary chamber (3) and a secondary chamber (4) separated by a semi-permeable membrane (5),
  - a blood circuit having an arterial line (6) intended to come from the patient, the filter's primary chamber (3) and a venous line (7) intended to return to the patient,
  - 10       – a dialysate circuit comprising the filter's secondary chamber (4) and at least one drain line (8) for circulating the waste intended to come from the filter (2) and intended to go to a drain (9),
  - a first bag (11) in fluid communication with the drain line (8),
  - at least one first gravimetric weighing means (21) linked to the first bag (11),
  - 15       – fluid flow rate adjustment means (31, 32, 33, 34) acting on the drain line (8),
  - a control unit (41) linked to the first gravimetric weighing means (21) and to the fluid flow rate adjustment means (31, 32, 33, 34),
- 20       **Characterized in that it comprises:**
- a second bag (12) in fluid communication with the drain line (8),
  - and in that the control unit (41) is capable of:
    - i. receiving weight signals from the first gravimetric weighing means and,
    - 25       ii. controlling the fluid flow rate adjustment means (31, 32, 33, 34) to load one of the bags (11, 12) with liquid while the other bag (12, 11) unloads liquid, and vice-versa.
- 30       **2.** A device according to claim 1 characterized in that the control unit (41) is capable of calculating, from the weight signals received, the amount of liquid coming from the filter and entering the drain line (8).
- 35       **3.** A device according to claim 1 or 2 characterized in that the adjustment means comprise a first adjustment organ (31) acting upstream of the two bags (11, 12) and in that the control unit (41) controls the first adjustment organ (31) to ensure the presence of a substantially continuous flow rate during the treatment.
4. A device according to claim 3 characterized in that the adjustment

means comprise a second adjustment organ (32) acting between the two bags (11, 12).

5 **5.** A device according to claim 4 characterized in that the adjustment means comprise a third adjustment organ (33) acting downstream of the two bags (11, 12).

**6.** A device according to claims 1-5, characterized in that the drain line (8) comprises:

- 10
- a conduit (80) intended to link the filter (2) to the drain (9),
  - a first branch (81) linking the first bag (11) to the conduit (80),
  - a second branch (82) linking the second bag (12) to the conduit (80),
  - the second branch (82) being connected to the conduit (80)
- 15 upstream of the first branch (81).

and in that the first adjustment organ (31) and the second adjustment organ (32) act on the conduit (80).

20 **7.** A device according to claim 6 characterized in that each branch (81, 82) comprises a line with two respective terminal connections (811, 812, 821, 822).

25 **8.** A device according to claim 6 or 7 characterized in that each branch (81, 82) comprises a direct connection between the drain line (80) and a bag opening.

30 **9.** A device according to one of claims 6 to 8 characterized in that first (31) and third (33) adjustment organs are peristaltic pumps, and the second adjustment organ (32) is a valve.

**10.** A device according to Claim 9 characterized in that the first bag (11) is placed lower than the second bag (12) so that the first bag (11) loads in priority and the second bag (12) unloads into the first bag (11) by gravity when the second adjustment organ (32) is opened.

35 **11.** A device according to claim 9 or 10 characterized in that the control unit (41) is capable of controlling the adjustment organs (31, 32, 33) according to the two following alternating phases.

- in the first phase: the control unit (41) controls the opening of the second adjustment organ (32) and the stopping of the third adjustment organ (33) to load the second bag (12) and unload the first bag (11) into the drain (9).

5 - in the second phase: the control unit (41) controls the opening of the first adjustment organ (31) and the stopping of the third adjustment organ (33) to unload the second bag (12) and load the first bag (11).

10 **12.** A device according to claim 7 characterized in that the adjustment means comprise a fourth adjustment organ (34) acting on the first branch (81) between the two connections (811, 812).

15 **13.** A device according to claim 12 characterized in that the first and fourth adjustment organs (31, 34) are peristaltic pumps and the second and third adjustment organs (32, 33) are valves.

**14.** A device according to claim 12 or 13 characterized in that the control unit (41) is capable of controlling the flow rate adjustment organs (31, 32, 33, 34) according to the two following alternating phases.

20 - in the first phase: the control unit (41) orders the closing of the second adjustment organ (32), the opening of the third adjustment organ (33), the activation of the fourth adjustment organ (34) in the bag-to-conduit direction,

25 - in the second phase: the control unit (41) orders the opening of the second adjustment organ (32), the closing of the third adjustment organ (33), the activation of the fourth adjustment organ (34) in the conduit-to-bag direction.

30 **15.** A device according to claims 1 to 5 characterized in that the second adjustment organ (32) comprises a hydraulic system having six ports (51, 52, 53, 54, 55, 56) distributed as follows:

a. a first input port (51) intended to be in fluid communication with the input portion of the drain line (8) intended to be linked to the filter (2),

35 b. a second output port (52) intended to be in fluid communication with the output portion of the drain line (8) intended to be linked to the drain (9),

c. a third input port (53) and a fourth output port (54) each intended to be in fluid communication with the first bag (11),

- d. a fifth input port (55) and a sixth output port (56) each intended to be in fluid communication with the second bag (12),

5 **16.** A device according to claim 15 characterized in that the hydraulic system of the second adjustment organ (32) comprises:

- a first line (57) intended to put the first input port (51) into fluid communication with each of two output ports (54 and 56) intended to communicate with each bag,
- 10 - two clamps (322, 324) placed respectively on each portion of the first line (57) connected to said two output ports (54 and 56),

and

- a second line (58) intended to put the second output port (52) into fluid communication with each of two input ports (53 and 55) intended to communicate with each bag,
- 15 - two other clamps (321, 323) placed respectively on each portion of the second line (58) connected to said two input ports (53 and 55),

20 **17.** A device according to claim 15 characterized in that the hydraulic system of the second adjustment organ (32) comprises:

- a first line (57) intended to put the first input port (51) into fluid communication with each of two output ports (53, 55) intended to communicate with each bag and a first three-way valve (325) capable of having the two following alternated positions.

25 

- o first position: putting the first input port (51) into fluid communication with the third output port (53) at the first bag (11).

30 

- o second position: putting the first input port (51) into fluid communication with the fifth output port (55) at the second bag (12).

- a second line (58) intended to put the second output port (52) into fluid communication with each of two input ports (54, 56) intended to communicate with each bag and a second three-way valve (326) capable of having the two corresponding following alternated positions.

35 

- o first position: putting the second output port (52) into fluid communication with the sixth input port (56), at the second bag (12),

- o second position: putting the second output port (52) into fluid

communication with the fourth input port (54), at the first bag (11),

- 5 **18.** A device according to claim 16 or 17 characterized in that the control unit (41) simultaneously controls the clamps (321, 323, 323, 324, 325, 326) of the second adjustment organ (32) so that the next two phases are alternated during the operation:
- in the first phase: the second bag (12) is loaded with liquid while the first bag (11) unloads to the drain (9).
  - 10 - in the second phase: the first bag (11) is loaded with liquid while the second bag (12) unloads to the drain (9).
- and in that the third adjustment organ (33) ensures a substantially continuous flow rate.
- 15 **19.** A device according to one of the previous claims characterized in that it comprises a second gravimetric weighing means (22) linked to the second bag (12) and linked to the control unit (41).
- 20.** A device according to one of the previous claims characterized in that  
20 the control unit (41) is capable of calculating the amount of fluid coming from the filter (2) and entering the drain line (8) from the weight signals received from the first gravimetric weighing means (21) and/or the second gravimetric weighing means (22).
- 25 **21.** A device according to one of the previous claims characterized in that the control unit (41) is capable of:
- receiving weight information from the first gravimetric weighing means (21) and/or from the second gravimetric weighing means (22),
  - calculating the actual fluid flow rate coming from the filter (2) and  
30 comparing it with a required flow rate,
  - controlling the actual fluid flow rate by the adjustment means to approach the required fluid flow rate coming from the filter (2).
- 22.** A device according to one of the previous claims characterized in that  
35 the control unit (41) is capable of:
- receiving weight information from the first gravimetric weighing means (21) and/or from the second gravimetric weighing means (22),
  - independently determining the filling status of each bag,

- control, from the filling status of each bag, an alternating and successive bag loading and unloading procedure.

5 **23.** A device according to one of the previous claim characterized in that the control unit (41) is capable of activating a control procedure comprising the two following alternating phases:

- in a first phase: controlling the actual flow rate of the adjustment means (31, 32, 33, 34) according to the required flow rate profile and the weight information coming from at least the first gravimetric weighing means (21),  
10
- in a second phase: controlling the actual flow rate of the adjustment means (31, 32, 33, 34) according to the required flow rate profile and the weight information coming from the first and second gravimetric weighing means (21, 22).

15

**24.** A device according to claim 23 characterized in that the control unit (41) is capable of activating a control procedure comprising two alternated phases and in that the control of the actual flow rate of the adjustment means (31, 32, 33, 34) during the first phase is also performed according  
20 to the weight information of the second gravimetric weighing means (22).

**25.** A device according to one of the previous claims characterized in that the control unit (41) is capable of:

- receiving weight information from the first gravimetric weighing means (21) and/or from the second gravimetric weighing means (22),  
25
- detecting the maximum and minimum threshold values for each of the bags  $P_{1min}$ ,  $P_{1max}$ ,  $P_{2min}$ ,  $P_{2max}$ ,
- controlling from the threshold values a bag loading and unloading procedure according to the following steps:  
30
  - o loading of one bag and unloading of the other bag,
  - o detection of a limit threshold,
  - o unloading of one bag and loading of the other bag,
  - o detection of another limit threshold.

35 **26.** A single-use line for use in the device according to one of claims 1 to 25 comprising at least two bags (11, 12) and four line parts, including:

- a first line part intended to conduct the liquid from the input of the single-use line (80) towards one of the two bags (11);

- a second line part intended to conduct liquid from said bag towards the output of the single-use line (80);
- a third line part intended to conduct the liquid from the input of the single-use line (80) towards the other bag (12, 11);
- 5 - a fourth line part intended to conduct liquid stored in the other bag (12, 11) towards the output of the single-use line (80).

10 **27.** A single-use line for use in the device according to one of claims 1 to 25 comprising:

- a drain line (8) to put the output of the filter (2) and the drain (9) into fluid communication,
- two bags (11, 12) each attached to the drain line (8) and intended to be attached to the treatment apparatus (1),
- 15 - at least two parts (31b, 33b) of the drain line (8) intended to work together respectively with the first adjustment organ (31) and the third adjustment organ (33).

20 **28.** A single-use line according to claim 27 for use in the device according to claims 1 to 14 or 19 to 25 characterized in that the drain line (8) comprises a conduit (80) to link the filter output to the drain and in that the conduit (80) comprises two connections (81, 82).

25 **29.** A single-use line according to claim 28 intended to work together with a device according to one of claims 9 to 11 comprising another part (32b) of the conduit (80) placed between the two connections (81, 82) and intended to work together with the second adjustment organ (32).

30 **30.** A single-use line according to claim 28 intended to work together with a device according to one of claims 12 to 14 characterized in that it comprises a fourth part (34b) included in the first branch (81) and intended to work together with the fourth adjustment organ (34).

35 **31.** A single-use line according to claim 27, characterized in that it comprises:

- an input portion of the line,
- an output portion of the line,
- and in that the drain line (8) comprises:

- a first line (57) intended to put the input portion of the drain line and a port to each bag into fluid communication, the first line being T-shaped,
- a second line (58) intended to put the output portion of the drain line and a second port to each bag into fluid communication, the second line being T-shaped,

**32.** A single-use line according to claim 27, characterized in that it comprises:

- an input portion of the line,
- an output portion of the line,
- and in that the drain line (8) comprises:
  - a first line (57) intended to put the input portion of the drain line and a port to each bag into fluid communication, the first line comprising a three-way valve with two inputs and one output for the selective connection of the output with one of the two outputs,
  - a second line (58) intended to put the output portion of the drain line and a second port to each bag into fluid communication, the second line comprising a three-way valve with two inputs and one output for the selective connection of the output with one of the two outputs.

**33.** An automatic draining method of the drain line implemented in a device according to one of claims 1 to 25 characterized in that it comprises two successive alternating phases:

- the first phase comprises the loading of a first bag (11, 12) with waste and the unloading of a second bag (12, 11) of waste into a drain at the output of the drain line, this phase being stopped as soon as at least one of the two bags (11, 12) reaches a first measured threshold weight.
- the second phase comprises the unloading of the first liquid bags (11, 12) into a drain at the output of the drain line and the loading of the second bag (12, 11) with waste liquid, this phase being stopped as soon as a second measured threshold weight is reached for the same bag and/or the other bag.





3/10

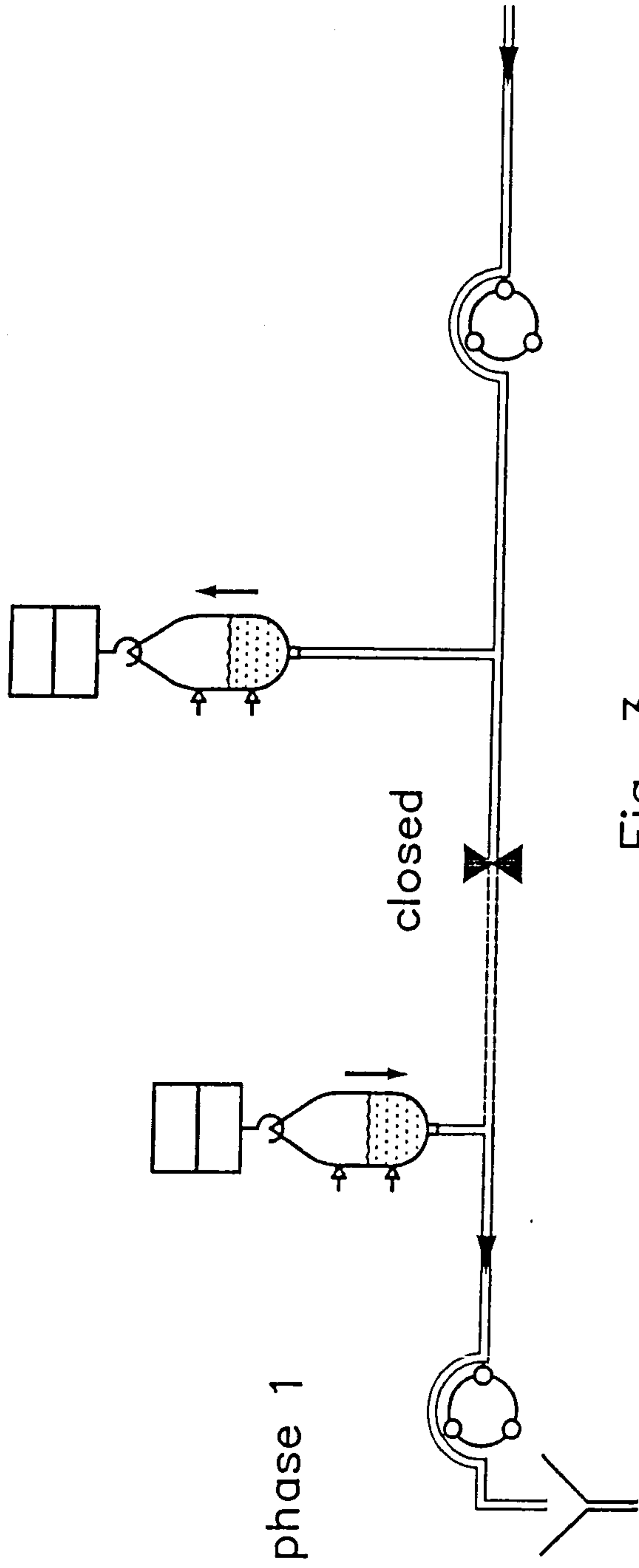

Fig. 3

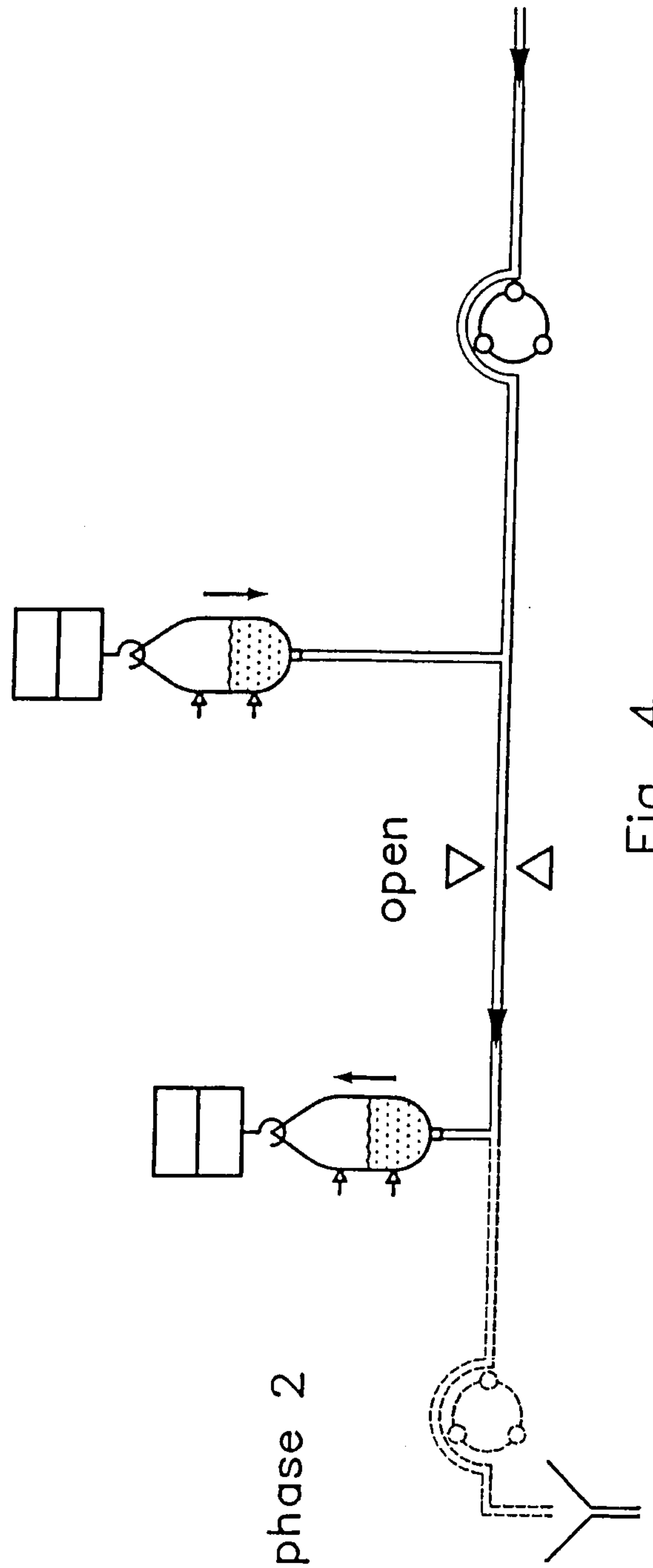

Fig. 4

Q effluent = 150 mL/min  
Q waste = 300 mL/min  
Delta H = 610 mm  
Waste time = 120s

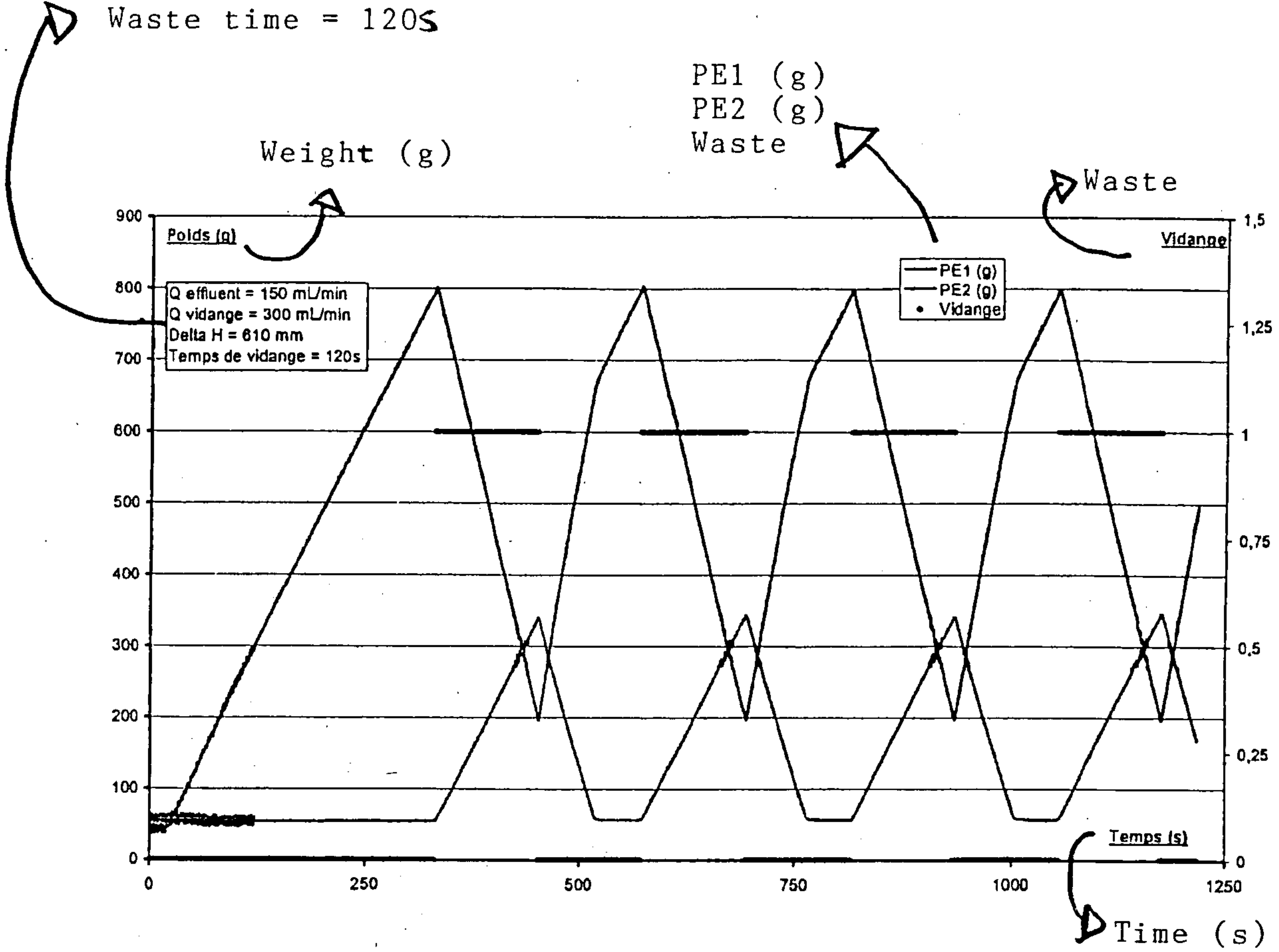
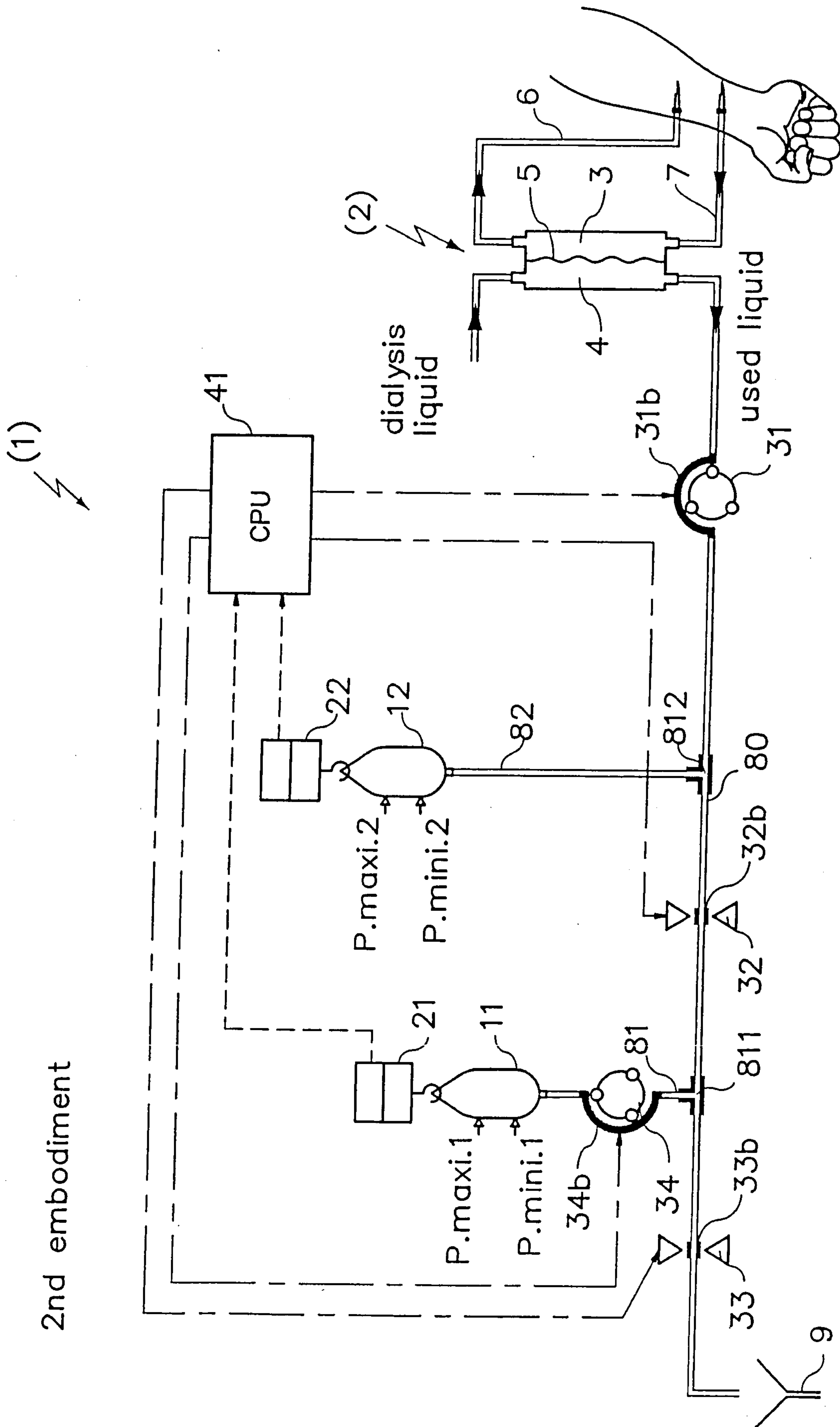

Fig. 5



2nd embodiment

Fig. 6

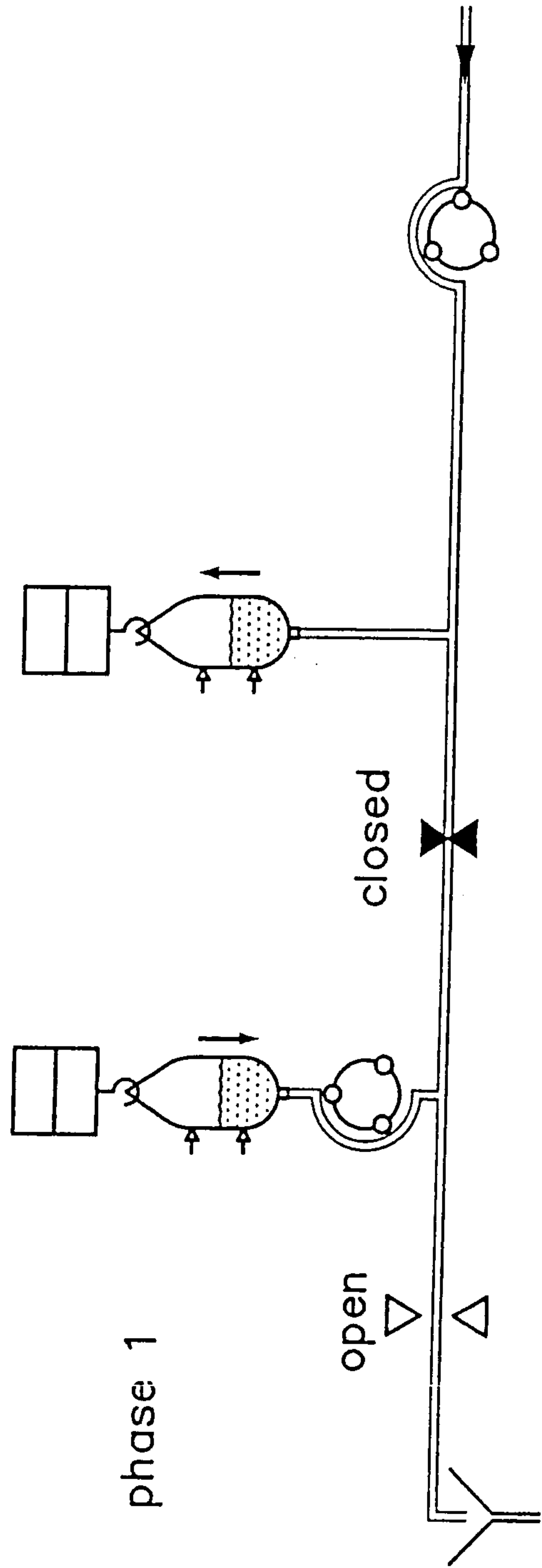

Fig. 7

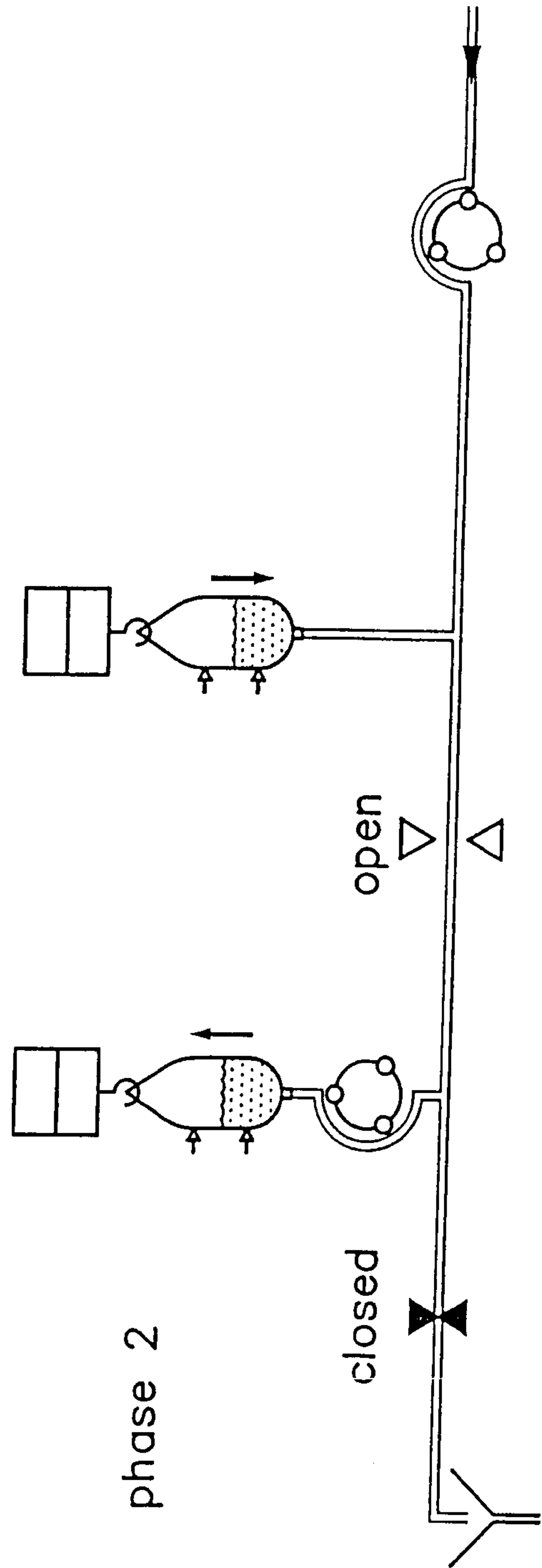

Fig. 8

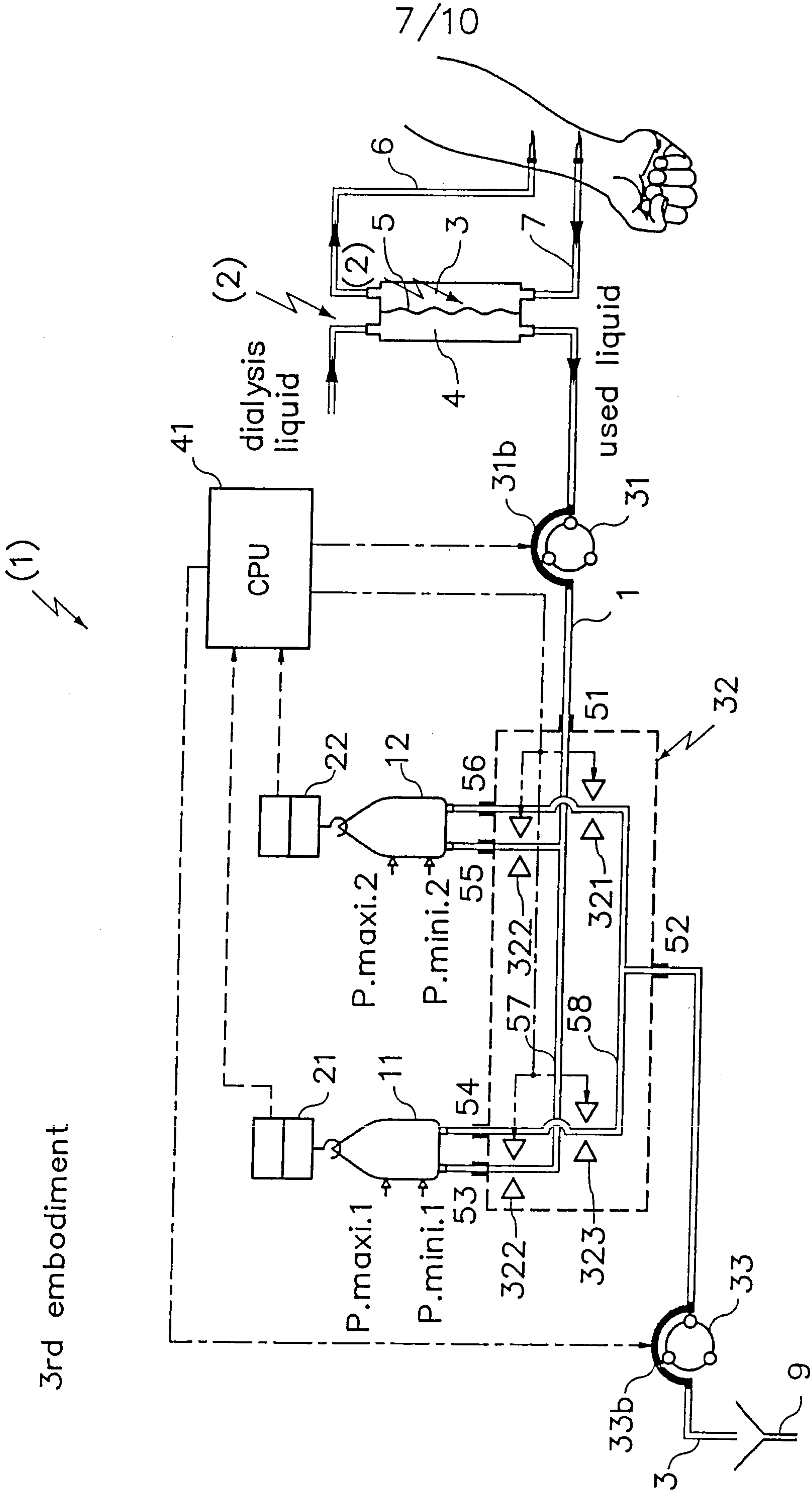
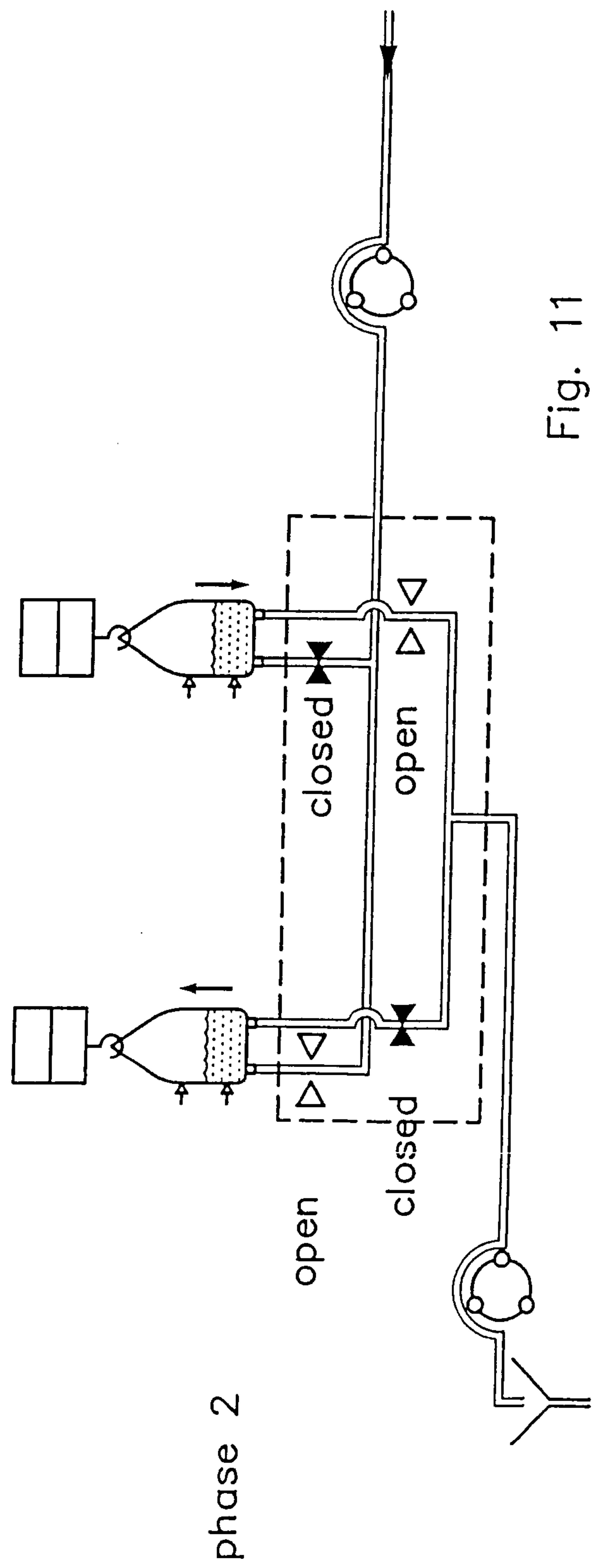
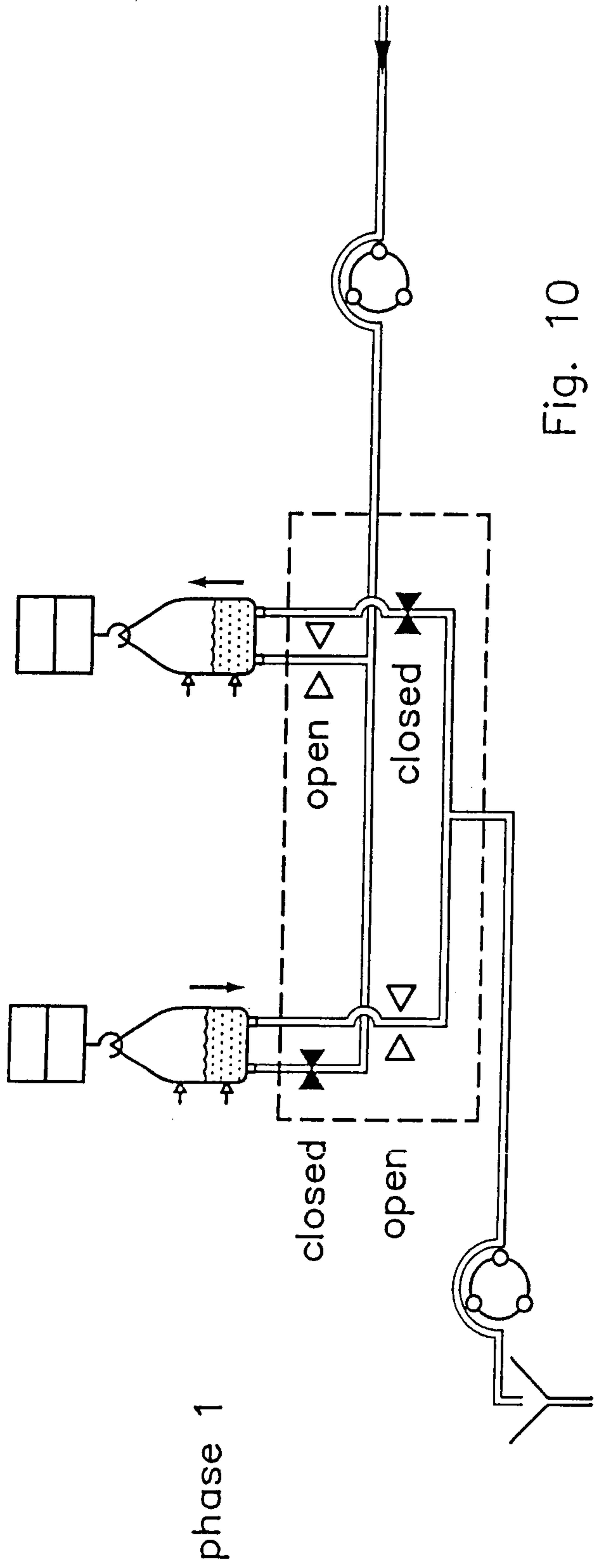
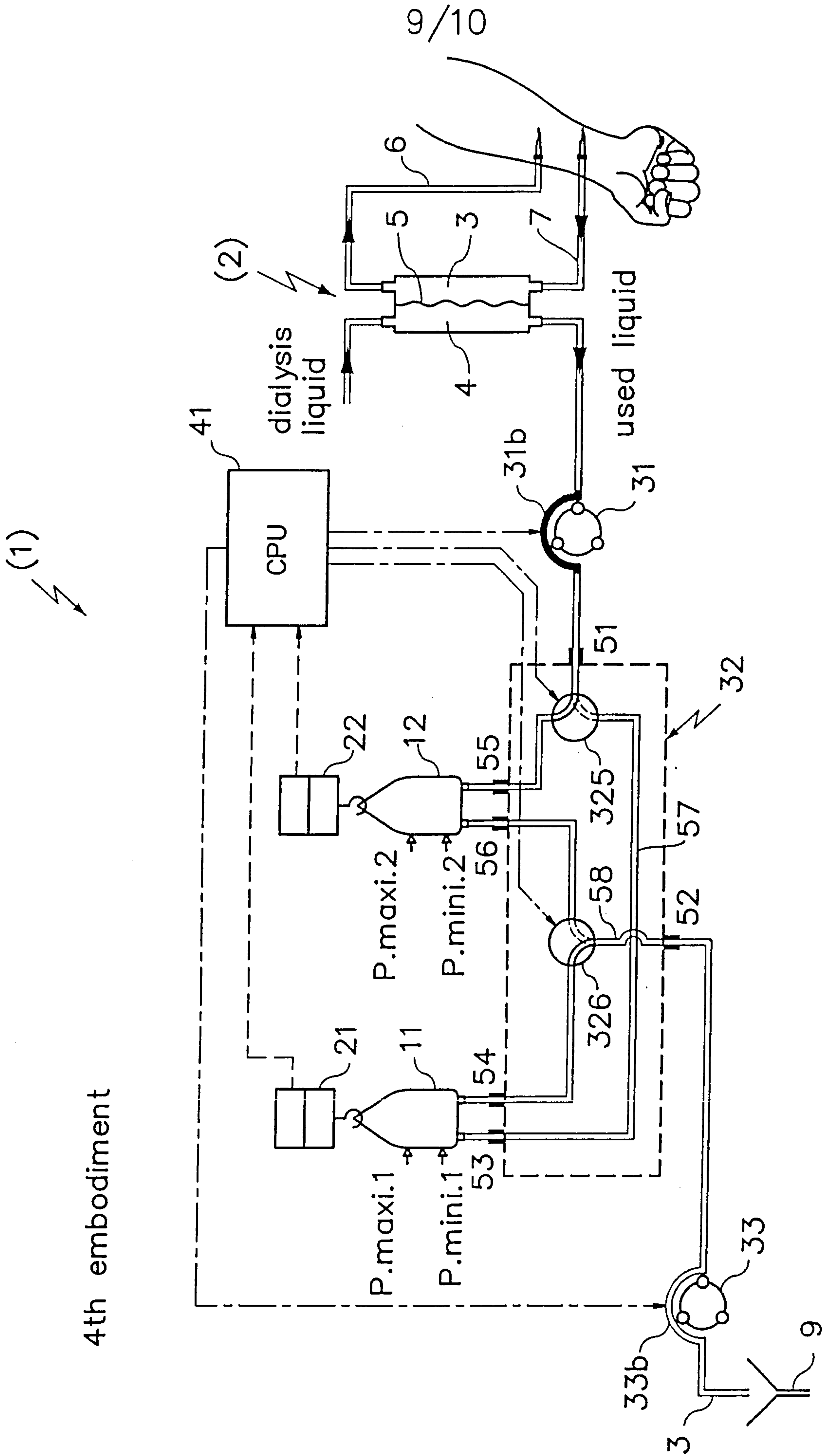

Fig. 9

3rd embodiment

7/10





4th embodiment

Fig. 12

10/10

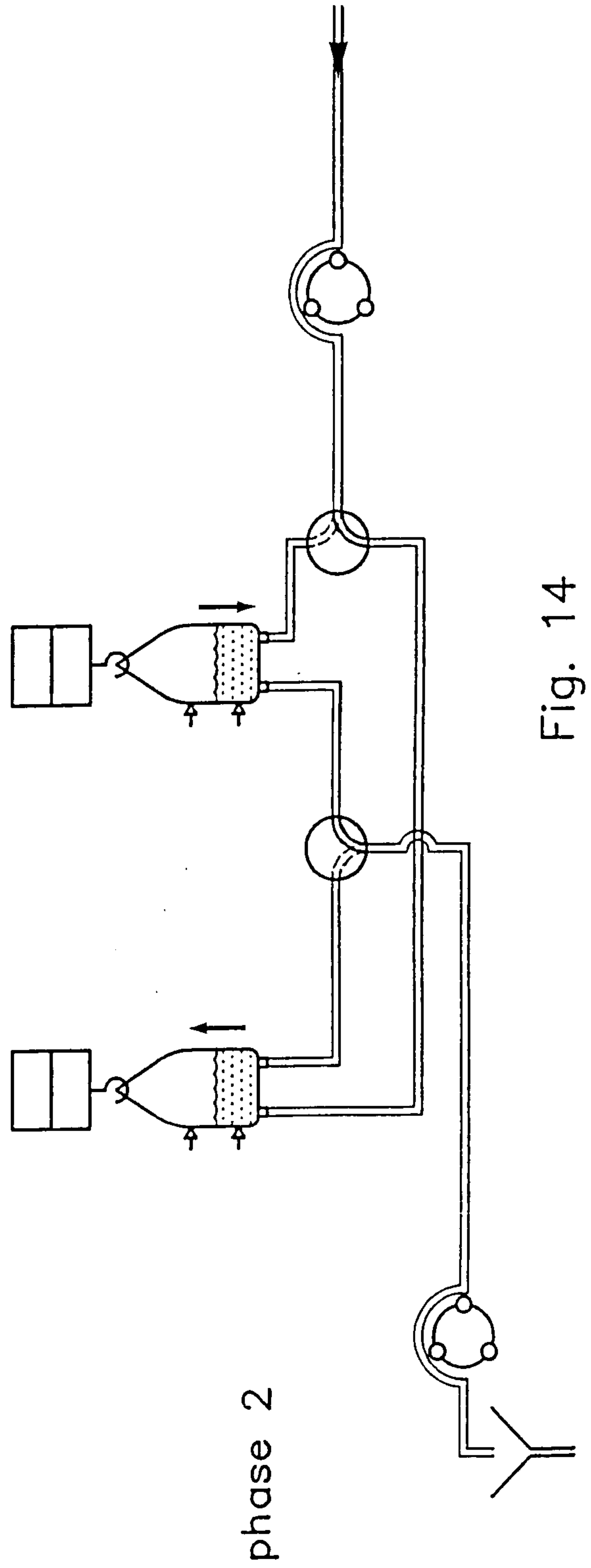
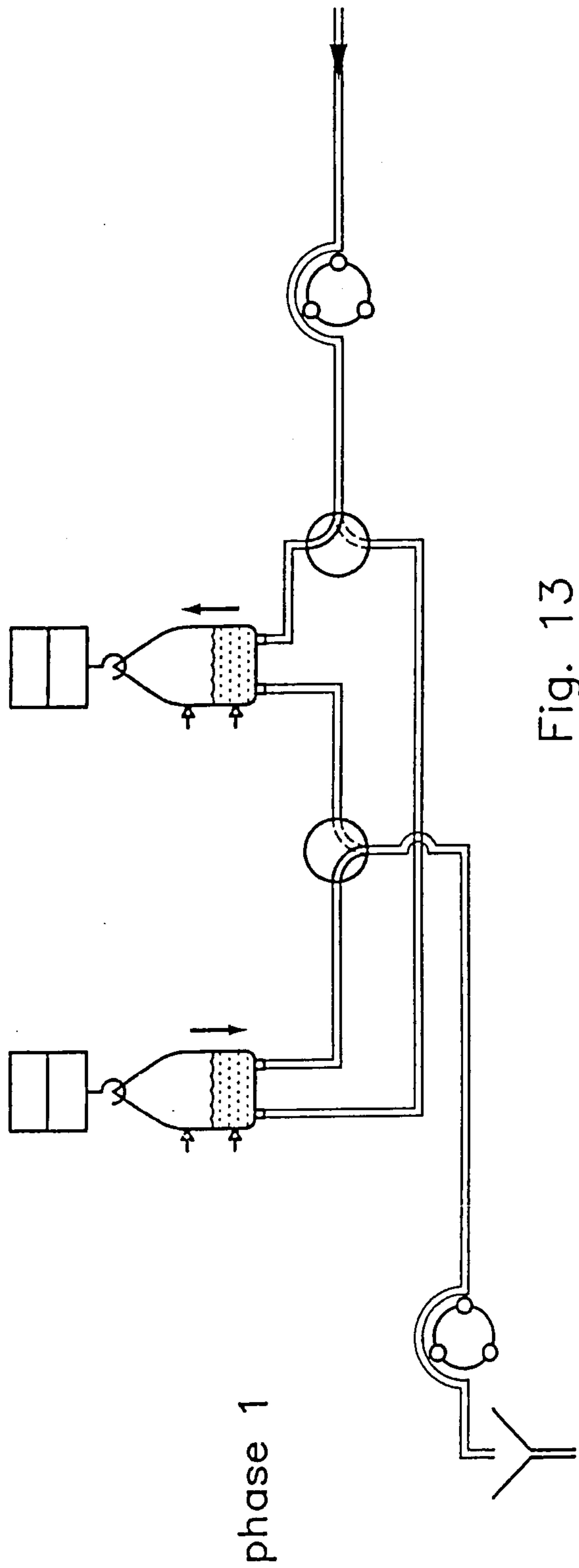

# 1er Mode de réalisation

(1)

