

O. BEHR.

Music-Stands.

No. 129,388.

Patented July 16, 1872.

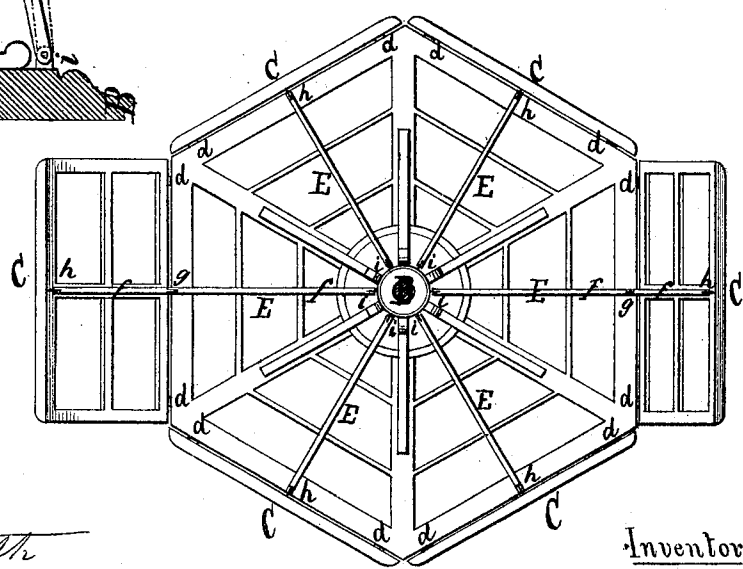
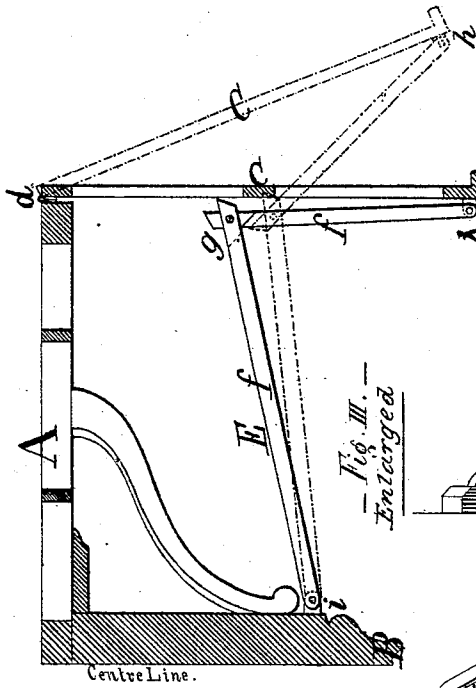
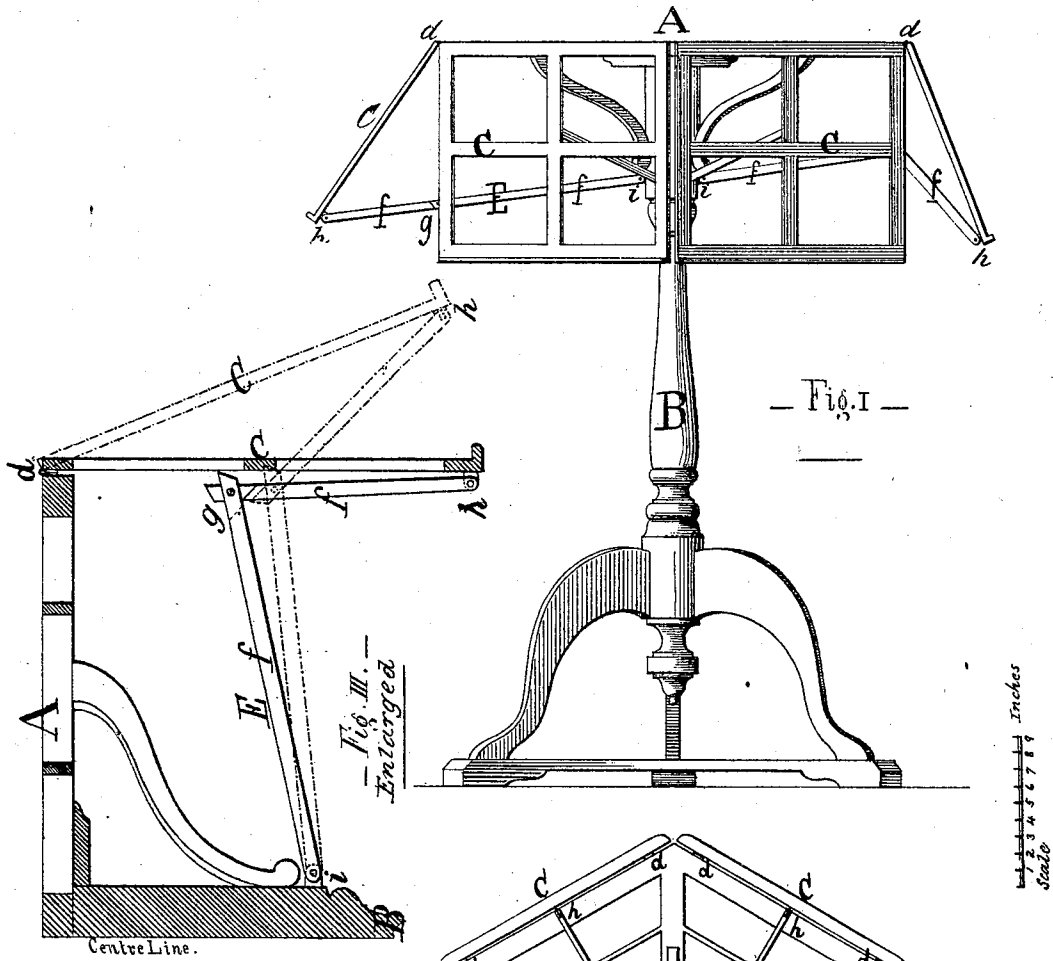

Witnesses:
B. Mackroth
Alfred Meier

— Fig. II —

Inventor
Otto Behr.

UNITED STATES PATENT OFFICE.

OTTO BEHR, OF ST. JOSEPH, MISSOURI.

IMPROVEMENT IN MUSIC-STANDS.

Specification forming part of Letters Patent No. 129,388, dated July 16, 1872.

Specification describing certain Improvements in Music Racks or Stands, invented by Professor OTTO BEHR, of St. Joseph, Buchanan county, and State of Missouri.

My invention consists of a simple, convenient, and practical combination of six self-adjusting music-racks, with a hexagonal-shaped table or stand resting on one leg, to which they are attached, for the convenience and use of duos, trios, quartettes, quintettes, sextettes, &c.

Figure 1 is a side elevation of the stand or table, embodying my invention. Fig. 2 is a view of the upper part of my invention from below or underneath. Fig. 3 is a section on an enlarged scale, showing the means by which the music-rack is raised or let down.

A is the top of my stand or table with the top of the leg fastened thereto. B is the leg. C, C, C, C, C, and C, are the six self-adjusting racks, each fastened to A by two hinges *d d*, and around the top of A to the six sides thereof. E is a self-adjusting elbow or joint, consisting of two pieces, *f f*, connected together at *g*, and connecting the music-rack C from the middle of its lower edge *h* with the leg B

at *i*. The top A must be constructed in such a manner that the six racks may be conveniently raised up and out for use and be supported by E. The six music-racks C, C, C, C, C, and C, should each consist of a frame with a small strip projecting out from the lower portion to prevent the music from slipping off. The elbow or joint E should be constructed to adjust itself to sustain the music-rack C in a position convenient for use.

For use the music-rack C is drawn out and upward until *g* falls to a straight line with *f* and *f*, when they will sustain C in position. After using, elbow E should be raised at *g* until rack C hangs perpendicularly. The stand may then be used as an ordinary center table or stand.

I claim as my invention—

The combination of the hexagonal top A with the six racks C, sustained by the jointed arms E, as and for the purposes hereinbefore set forth.

OTTO BEHR.

Witnesses:

A. L. BARTLETT,
FRED. LEDERGERBER.