

(19) World Intellectual Property
Organization
International Bureau



(43) International Publication Date
24 February 2005 (24.02.2005)

PCT

(10) International Publication Number
WO 2005/016050 A1

- (51) International Patent Classification⁷: **A43B 13/20**, 17/03, 21/28
- (21) International Application Number: PCT/US2004/017434
- (22) International Filing Date: 30 June 2004 (30.06.2004)
- (25) Filing Language: English
- (26) Publication Language: English
- (30) Priority Data: 10/628,567 29 July 2003 (29.07.2003) US
- (71) Applicant (for JP, KR only): **NIKE, INC.** [US/US]; One Bowerman Drive, Beaverton, OR 97005-6453 (US).
- (71) Applicant (for all designated States except JP, KR, US): **NIKE INTERNATIONAL LTD.** [GB/US]; One Bowerman Drive, Beaverton, OR 97005-6453 (US).
- (72) Inventors; and
- (75) Inventors/Applicants (for US only): **SWIGART, John, F.** [US/US]; 14024 N.W. Eagleridge Lane, Portland, OR 97229 (US). **HAZENBERG, K., Peter** [NL/US]; 4290 N.W. 192nd Avenue, Portland, OR 97229 (US).
- (74) Agent: **KUZARA, Byron, S.**; Banner & Witcoff, Ltd., 11th Floor, 1001 G. Street, NW, Washington, D.C. 20001-4597 (US).
- (81) Designated States (unless otherwise indicated, for every kind of national protection available): AE, AG, AL, AM, AT, AU, AZ, BA, BB, BG, BR, BW, BY, BZ, CA, CH, CN, CO, CR, CU, CZ, DE, DK, DM, DZ, EC, EE, EG, ES, FI, GB, GD, GE, GH, GM, HR, HU, ID, IL, IN, IS, JP, KE, KG, KP, KR, KZ, LC, LK, LR, LS, LT, LU, LV, MA, MD, MG, MK, MN, MW, MX, MZ, NA, NI, NO, NZ, OM, PG, PH, PL, PT, RO, RU, SC, SD, SE, SG, SK, SL, SY, TJ, TM, TN, TR, TT, TZ, UA, UG, US, UZ, VC, VN, YU, ZA, ZM, ZW.
- (84) Designated States (unless otherwise indicated, for every kind of regional protection available): ARIPO (BW, GH,

[Continued on next page]

(54) Title: ARTICLE OF FOOTWEAR INCORPORATING AN INFLATABLE CHAMBER

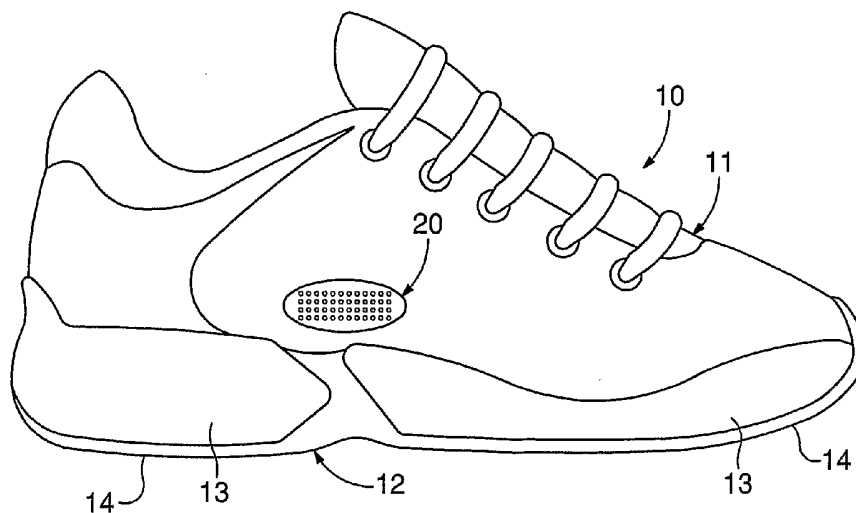

(57) Abstract: An article of footwear is disclosed that includes a fluid system having a pump chamber (60) and an inflatable pressure chamber (70). The pressure chamber (70) is configured to extend at least partially around the pump chamber (60) to limit the pressure of a fluid within the pressure chamber. The relative elevation of the pump chamber and pressure chamber may be selected, for example, such that the pump chamber is within an elevation defined by the upper and lower surfaces of the pressure chamber. The fluid system may be substantially formed from a pair of polymer layers that are bonded together to form the pump chamber and the pressure chamber, and the fluid system includes valves (50a, 50b) located between the layers.

WO 2005/016050 A1



GM, KE, LS, MW, MZ, NA, SD, SL, SZ, TZ, UG, ZM, ZW), Eurasian (AM, AZ, BY, KG, KZ, MD, RU, TJ, TM), European (AT, BE, BG, CH, CY, CZ, DE, DK, EE, ES, FI, FR, GB, GR, HU, IE, IT, LU, MC, NL, PL, PT, RO, SE, SI, SK, TR), OAPI (BF, BJ, CF, CG, CI, CM, GA, GN, GQ, GW, ML, MR, NE, SN, TD, TG).

Published:

— *with international search report*

For two-letter codes and other abbreviations, refer to the "Guidance Notes on Codes and Abbreviations" appearing at the beginning of each regular issue of the PCT Gazette.

ARTICLE OF FOOTWEAR INCORPORATING AN INFLATABLE CHAMBER

BACKGROUND OF THE INVENTION

Field of the Invention

- [01] The present invention relates to footwear. The invention concerns, more particularly, an article of footwear incorporating a fluid system that inflates a chamber within the fluid system and limits pressure of a fluid within the chamber.

Description of Background Art

- [02] Conventional articles of athletic footwear include two primary elements, an upper and a sole structure. The upper is usually formed of leather, synthetic materials, or a combination thereof and comfortably secures the footwear to the foot, while providing ventilation and protection from the elements. The sole structure often incorporates multiple layers that are conventionally referred to as an insole, a midsole, and an outsole. The insole is a thin, cushioning member located within the upper and adjacent the sole of the foot to enhance footwear comfort. The midsole is traditionally attached to the upper along the entire length of the upper and forms the middle layer of the sole structure. The outsole forms the ground-contacting element of footwear and is usually fashioned from a durable, wear resistant material that includes texturing to improve traction.
- [03] The primary material forming a conventional midsole is a resilient, polymer foam, such as polyurethane or ethylvinylacetate, that extends throughout the length of the footwear. A polymer foam midsole may also incorporate a fluid-filled chamber, having the configuration of a bladder, to enhance ground reaction force attenuation and energy absorption characteristics of the sole structure. U.S. Patent Number 4,183,156 to Rudy provides an example of a fluid-filled chamber that includes an outer enclosing member formed of an elastomeric material. The outer enclosing material defines a plurality of tubular members in fluid communication with each other.
- [04] The fluid-filled chamber described above may be manufactured by a two-film technique, wherein two separate layers of elastomeric film are formed to have the overall shape of

the chamber. The layers are then welded together along their respective peripheries to form an upper surface, a lower surface, and sidewalls of the chamber, and the layers are welded together at predetermined interior locations to impart a desired configuration to the chamber. That is, interior portions of the layers are connected to form subchambers of a predetermined shape and size at desired locations. The chamber is subsequently pressurized above ambient pressure by inserting a nozzle or needle, which is connected to a fluid pressure source, into a fill inlet formed in the chamber. After the chamber is pressurized, the nozzle is removed and the fill inlet is sealed, by welding for example.

- [05] Another method of manufacturing a fluid-filled chamber is through a blow-molding process, as generally disclosed in U.S. Patent Number 5,353,459 to Potter et al., wherein a liquefied elastomeric material is placed in a mold having the desired overall shape and configuration of the bladder. The mold has an opening at one location through which pressurized air is provided. The pressurized air forces the liquefied elastomeric material against the inner surfaces of the mold and causes the material to harden in the mold, thereby forming a chamber with the desired shape and configuration. In addition, fluid-filled chambers may be manufactured through a thermoforming process, as disclosed in U.S. Patent Number 5,976,451 to Skaja, et al., wherein a pair of sheets of flexible thermoplastic resin are placed against a pair of molds having a vacuum system for properly shaping the two sheets. The mold portions are then closed to seal the two sheets around their peripheries and form the bladder.
- [06] An article of footwear may also incorporate a fluid system that includes various components, including a pressure chamber, a pump chamber for increasing the pressure in the pressure chamber, one or more valves for regulating the direction and rate of fluid flow, and conduits that connect the various fluid system components. U.S. Patent Number 6,457,262 to Swigart discloses a fluid system having a central chamber and two side chambers positioned medially and laterally of the central chamber. Each of the side chambers are in fluid communication with the central chamber through at least one conduit that includes a valve. Accordingly, a fluid contained by the fluid system may flow from the central chamber to side chambers, and the fluid may flow from the side chambers to the central chamber. Examples of other fluid systems that are sealed to

prevent the entry or exit of ambient air are disclosed in U.S. Patent Numbers 5,950,332 to Lain; 5,794,361 to Sadler; and 4,446,634 to Johnson et al., for example.

- [07] Fluid systems incorporated into an article of footwear may also utilize ambient air as the system fluid. U.S. Patent Number 5,826,349 to Goss discloses an article of footwear having a fluid system that utilizes ambient air to ventilate an interior of an upper. The fluid system includes an intake positioned on the upper and a conduit leading from the intake to a plurality of chambers that are in fluid communication. Valves associated with the chambers prevent the air from escaping through the intake when the chambers are compressed. Rather, the air is forced out of the chambers through another conduit that leads to the interior of the upper. U.S. Patent Number 5,937,462 to Huang disclose a fluid system that utilizes ambient air to pressurize a chamber within a sole structure of an article of footwear.

SUMMARY OF THE INVENTION

- [08] The present invention is a fluid system for an article of footwear. The fluid system includes a pump chamber, a pressure chamber, a fluid path, and a valve. The pressure chamber extends around at least a portion of the pump chamber, and the fluid path extends between the pump chamber and the pressure chamber to place the pump chamber and the pressure chamber in fluid communication. The valve is positioned within the fluid path to permit fluid flow from the pump chamber to the pressure chamber and to limit fluid flow from the pressure chamber to the pump chamber.
- [09] The pressure chamber may have a curved configuration that defines an interior area within the curved configuration, and the pump chamber may be positioned within the interior area. The pressure chamber may also be substantially located at an elevation of the pump chamber. Upon compression of the pump chamber, the fluid within the pump chamber enters the fluid path, passes through the valve, and passes into the pressure chamber, thereby adding more fluid to the pressure chamber and increasing the pressure of the fluid within the pressure chamber.

- [10] Following transfer of the fluid to the pressure chamber, the fluid within the pump chamber is replenished through additional fluid paths and valves that may be incorporated into the fluid system to provide access to a fluid source or ambient air, for example. In addition, a filter assembly may be incorporated into the fluid system to limit particulates and water from entering the fluid system. The fluid system may be formed from two coextensive sheets of polymer material that are bonded together to form the first chamber, the second chamber, and the fluid path, with valve being positioned between the sheets of polymer material.
- [11] The advantages and features of novelty characterizing the present invention are pointed out with particularity in the appended claims. To gain an improved understanding of the advantages and features of novelty, however, reference may be made to the following descriptive matter and accompanying drawings that describe and illustrate various embodiments and concepts related to the invention.

DESCRIPTION OF THE DRAWINGS

- [12] The foregoing Summary of the Invention, as well as the following Detailed Description of the Invention, will be better understood when read in conjunction with the accompanying drawings.
- [13] Figure 1 is a lateral side elevational view of an article of footwear incorporating an exemplar fluid system in accordance with the present invention.
- [14] Figure 2 is a partial cut-away view of the footwear depicting the fluid system.
- [15] Figure 3 is a perspective view of the fluid system.
- [16] Figure 4 is a top plan view of the fluid system.
- [17] Figure 5 is a first cross-sectional view, as defined along line 5-5 in Figure 4.
- [18] Figure 6 is a second cross-sectional view, as defined along line 6-6 in Figure 4.
- [19] Figure 7 is a third cross-sectional view, as defined along line 7-7 in Figure 4.

- [20] Figure 8A is a top plan view of another exemplar fluid system in accordance with the present invention.
- [21] Figure 8B is a cross-sectional view, as defined along line 8B-8B in Figure 8A.
- [22] Figure 9A is a top plan view of yet another exemplar fluid system in accordance with the present invention.
- [23] Figure 9B is a cross-sectional view, as defined along line 9B-9B in Figure 9A.
- [24] Figure 10A is a perspective view of a valve suitable for use in the fluid system.
- [25] Figure 10B is a first cross-sectional view of the valve, as defined by line 10B-10B in Figure 10A.
- [26] Figure 10C is a second cross-sectional view of the valve, as defined by line 10C-10C in Figure 10A.
- [27] Figure 10D is a third cross-sectional view of the valve, as defined by line 10D-10D in Figure 10A.
- [28] Figure 10E is a fourth cross-sectional view of the valve, as defined by line 10E-10E in Figure 10A.
- [29] Figure 10F is a fifth cross-sectional view of the valve, as defined by line 10F-10F in Figure 10A.
- [30] Figure 10G is an enlarged view of a weld bead depicted in Figure 10D.

DETAILED DESCRIPTION OF THE INVENTION

- [31] The following discussion and accompanying figures disclose fluid systems in accordance with the present invention that are suitable for footwear applications. Concepts related to the fluid systems are disclosed with reference to an article of athletic footwear having a configuration intended for the sport of running. The fluid systems are not solely limited

to footwear designed specifically for the sport of running, however, and may be incorporated into a wide range of athletic footwear styles, including basketball shoes, cross-training shoes, walking shoes, tennis shoes, soccer shoes, and hiking boots, for example. In addition, the fluid systems may be incorporated into non-athletic footwear styles, including dress shoes, loafers, sandals, and work boots. Accordingly, an individual skilled in the relevant art will appreciate that the concepts disclosed herein with regard to the fluid systems apply to a wide variety of footwear styles, in addition to the specific style discussed in the following material and depicted in the accompanying figures.

- [32] An article of footwear 10 is depicted in Figure 1 and includes an upper 11 and a sole structure 12. Upper 11 has a substantially conventional configuration formed of a plurality elements, such as textiles, foam, and leather materials, that are stitched or adhesively bonded together to form an interior void for securely and comfortably receiving the foot. Sole structure 12 is positioned below upper 11 and includes two primary elements, a midsole 13 and an outsole 14. Midsole 13 is secured to a lower surface of upper 11, through stitching or adhesive bonding, for example, and operates to attenuate ground reaction forces and absorb energy as sole structure 12 contacts the ground. That is, midsole 13 is structured to provide the foot with cushioning during walking or running, for example. Outsole 14 is secured to a lower surface of midsole 13 and is formed of a durable, wear-resistant material that engages the ground. In addition, sole structure 12 may include an insole (not depicted), which is a thin cushioning member located within the void within upper 11 and adjacent to the foot to enhance the comfort of article of footwear 10.
- [33] Midsole 13 is primarily formed of a polymer foam material, such as polyurethane or ethylvinylacetate, that at least partially encapsulates a fluid system 20. As depicted in Figure 2, fluid system 20 is positioned in a heel region of midsole 13, which corresponds with the area of highest initial force during footstrike. Fluid system 20 may, however, be positioned in any region of midsole 13 to impart a desired degree of cushioning response, stability, or other midsole properties. Furthermore, midsole 13 may incorporate multiple fluid systems 20, with a first fluid system 20 being positioned in the heel region and a

second fluid system 20 being positioned in a forefoot region of midsole 13, for example. Fluid system 20 may also have a configuration that extends from the heel region to the forefoot region of midsole 13, thereby extending through a substantial portion of midsole 13.

- [34] Fluid system 20 is depicted individually in Figures 3-7 and provides a structure that utilizes ambient air to impart additional force attenuation and energy absorption as sole structure 12 contacts the ground. That is, fluid system 20 provides cushioning to supplement the cushioning provided by the polymer foam material of midsole 13. In addition, fluid system 20 may provide stability, improve the responsiveness, and enhance the ride characteristics of midsole 13. The primary elements of fluid system 20 are a filter assembly 30, a pair of conduits 40a and 40b, a pair of valves 50a and 50b that are positioned within conduits 40a and 40b, respectively, a pump chamber 60, and a pressure chamber 70. In operation, a fluid, such as ambient air, is drawn into conduit 40a by passing through filter assembly 30. The fluid then passes through valve 50a and into pump chamber 60. As pump chamber 60 is compressed, the fluid enters conduit 40b and passes through valve 50b to enter pressure chamber 70. A combination of the fluid within pump chamber 60 and pressure chamber 70 imparts the cushioning that is provided by fluid system 20. In some embodiments, however, a majority of the cushioning provided by fluid system 20 is imparted by pressure chamber 70.
- [35] A pair of polymer layers 21 and 22 are bonded together at specific bonding locations 23 to define conduits 40a and 40b, pump chamber 60, and pressure chamber 70 within fluid system 20. That is, conduits 40a and 40b, pump chamber 60, and pressure chamber 70 are formed at unbonded positions of polymer layers 21 and 22. The position of conduit 40a with respect to polymer layers 21 and 22 is selected to provide a fluid path that extends between a fluid source, such as ambient air, and pump chamber 60, thereby permitting the fluid to flow from filter assembly 30 to pump chamber 60. Similarly, the position of conduit 40b is selected to provide a fluid path that extends between pump chamber 60 and pressure chamber 70, which permits the fluid to also flow from pump chamber 60 to pressure chamber 70. In this configuration, therefore, the fluid may flow between polymer layers 21 and 22 to pass through conduits 40a and 40b.

- [36] The position of pressure chamber 70 is also selected such that a portion of pressure chamber 70 extends at least partially around a side portion of pump chamber 60. The degree to which pressure chamber 70 extends around the side portion of pump chamber 60 is a design consideration that may be determined in accordance with the specific application in which fluid system 20 is being used. As will be discussed in the following material, the degree to which pressure chamber 70 extends around the side portion of pump chamber 60 contributes to a pressure-limiting feature of fluid system 20. In the various embodiments of fluid system 20, pressure chamber 70 may extend entirely around the side portion of pump chamber 60, or pressure chamber 70 may be configured to extend only partially around the side portion of pump chamber 60. As depicted in Figures 3 and 4, for example, pressure chamber 70 forms a generally C-shaped structure with an interior area that accommodates pump chamber 60. Accordingly, pressure chamber 70 extends around a substantial portion of pump chamber 60. In other embodiments of fluid system 20, however, pressure chamber 70 may extend only partially around the side portion of pump chamber 60. As depicted in the figures, however, pressure chamber 70 forms a curved structure with an interior area for positioning pump chamber 60. End portions of pressure chamber 70 may also be extended to form a U-shaped structure with an interior area for also receiving portions of conduits 40a and 40b, as depicted in Figures 8A and 9A.
- [37] A variety of materials are suitable for polymer layers 21 and 22, including barrier materials that are substantially impermeable to the fluid within fluid system 20. Such barrier materials may include, for example, alternating layers of thermoplastic polyurethane and ethylene-vinyl alcohol copolymer, as disclosed in U.S. Patent Numbers 5,713,141 and 5,952,065 to Mitchell et al. A variation upon this material wherein the center layer is formed of ethylene-vinyl alcohol copolymer, the two layers adjacent to the center layer are formed of thermoplastic polyurethane, and the outer layers are formed of a regrind material of thermoplastic polyurethane and ethylene-vinyl alcohol copolymer may also be utilized. Another suitable material is a flexible microlayer material that includes alternating layers of a gas barrier material and an elastomeric material, as disclosed in U.S. Patent Numbers 6,082,025 and 6,127,026 to Bonk et al.

- [38] Although polymer layers 21 and 22 may be formed of the barrier materials discussed above, more economical thermoplastic elastomer materials that are at least partially impermeable to the fluid within fluid system 20 may also be utilized. As discussed above, fluid system 20 operates to draw fluid, such as air, into pump chamber 60 and pressure chamber 70 in order to provide cushioning to article of footwear 10. If a portion of the fluid within pump chamber 60 or pressure chamber 70 should escape from fluid system 20 by passing through polymer layers 21 and 22, then fluid system 20 will operate to draw additional fluid into pump chamber 60 and pressure chamber 70, thereby replenishing the escaped fluid. Accordingly, polymer layers 21 and 22 need not provide a barrier that is substantially impermeable to the fluid within fluid system 20, but may be at least partially impermeable to the fluid within fluid system 20. Suitable polymer materials include, therefore, thermoplastic elastomers such as polyurethane, polyester, polyester polyurethane, and polyether polyurethane. In addition to decreased manufacturing costs, a benefit of utilizing these thermoplastic elastomers is that the specific material forming polymer layers 21 and 22 may be selected based primarily upon the engineering properties of the material, rather than the barrier properties of the material. Accordingly, the material forming polymer layers 21 and 22 may be selected to exhibit a specific tensile strength, elastic modulus, durability, degree of light transmission, elasticity, resistance to corrosion or chemical breakdown, or abrasion resistance, for example.
- [39] Filter assembly 30 has the general structure of a filter assembly described in U.S. Patent Application Serial Number 09/887,523, which was filed June 21, 2001 and is hereby entirely incorporated by reference. Filter assembly 30 is generally positioned on an exterior of article of footwear 10 and includes two primary components, a cover element 31 and a filter material 32. Cover element 31 extends over filter material 32 and includes a plurality of perforations that permit air to access filter material 32, while preventing relatively large objects, such as stones and tree branches, from directly contacting and potentially damaging filter material 32. The fluid is drawn into fluid system 20 through filter material 32, which limits water, other liquids, and a variety of particulates from hindering the operation of various system components, such as valves 50a and 50b and pressure chamber 70. If permitted to enter fluid system 30, particulates, for example,

could collect around and within valves 50a and 50b. As will be discussed in greater detail below, valves 50a and 50b are one-directional valves that permit fluid to flow in a first direction, but limit or check fluid flow in an opposite second direction. Particulates that collect around and within valves 50a and 50b may affect the one-directional operation of valves 50a and 50b, thereby permitting the fluid to flow through fluid system 20 in an unintended manner. In the absence of filter assembly 30, water and particulates could also collect within pressure chamber 70. In some embodiments of the present invention, a portion of pressure chamber 70 may be visible through apertures formed in the polymer foam material of midsole 13. Particulates that collect within pressure chamber 70 could become visible from the exterior of article of footwear 10, thereby decreasing the aesthetic properties of article of footwear 10. If water were also permitted to enter and collect in pump chamber 60, pressure chamber 70, or other portions of fluid system 20, the weight of article of footwear 10 may increase significantly. Furthermore, particulates may act as an abrasive that wears away portions of fluid system 20, thereby decreasing durability. Accordingly, filter assembly 30 acts to limit the entry of liquids and particulates that may have a detrimental effect upon fluid system 20.

[40] One suitable material for filter material 32 is polytetrafluoroethylene (PTFE), which may be deposited on a substrate material. PTFE exhibits the required characteristics and is suitably durable when attached to a substrate such as non-woven polyester. A variation upon the standard formulation of PTFE is expanded polytetrafluoroethylene (ePTFE) which is manufactured by, for example, W.L. Gore & Associates. In addition to PTFE, other suitable materials for filter material 32 include high density polyethylene, ultrahigh molecular weight polyethylene, polyvinylidene fluoride, polypropylene, and certain ceramic filter materials. Knit materials, woven materials, nonwoven materials, laminate structures consisting of one or more differing filter materials, and paper may also be suitable. In addition, filter material 32 may be formed of a solid, porous material.

[41] Valves 50a and 50b may be any type of valve that performs in accordance with the design requirements of system 20. Valve structures that may be utilized for valves 50a and 50b include, for example, duckbill valves manufactured by Vernay Laboratories, Inc. and the two-layer polymer valves disclosed in U.S. Patent Numbers 5,144,708 to Pekar and

5,564,143 to Pekar et al. Both types of valves are generally considered one-directional valves that permit fluid flow in a first direction, but limit fluid flow in an opposite second direction. With respect to fluid system 20, valve 50a permits fluid flow in the direction from filter assembly 30 to pump chamber 60, and valve 50b permits fluid flow in the direction from pump chamber 60 to pressure chamber 70. Valves 50a and 50b, however limit fluid flow in opposite directions. Depending upon the specific characteristics that a fluid system is intended to impart, valves that permit fluid flow in both directions may also be utilized within the scope of the present invention. In addition to the valve structures disclosed above, valves 50a and 50b may also have the configuration of a valve 100, which is described with reference to Figures 10A-10G following a more detailed discussion regarding the operation of fluid system 20.

- [42] Fluid system 20 is configured to provide an air inlet that is separate from pump chamber 60. With reference to Figures 3 and 4, fluid system 20 is depicted as having an air inlet at filter assembly 30, and conduit 40a extends between filter assembly 30 and pump chamber 60. Accordingly, air is introduced into fluid system 20 through an air inlet that is separate from pump chamber 60. The separate air inlet and pump chamber 60 permits the air inlet to be located on any portion of footwear 10, including upper 11, and this configuration permits the air inlet to include a filter material 32 that is not positioned in an area of repetitive compressive forces.
- [43] Another feature of fluid system 20 is the direct fluid communication between pump chamber 60 and pressure chamber 70. Conduit 40b leads directly from pump chamber 60 to pressure chamber 70 and provides an area for positioning valve 50b. Accordingly, a minimum number of fluid system components are placed in the fluid path between pump chamber 60 and pressure chamber 70. This configuration reduces the pressure losses that arise through transfer of the fluid from pump chamber 60 to pressure chamber 70. Furthermore, this configuration provides a fluid system with a relatively small number of components.
- [44] The operation of fluid system 20 will now be discussed in detail. The pressure of the fluid within the various components of fluid system 20 changes depending upon the

manner in which article of footwear 10 is utilized, the frequency at which sole structure 12 is compressed, and the force that compresses sole structure 12, for example. For purposes of the present discussion, the operation of fluid system 20, and the pressure of the fluid within the various components of fluid system 20 will be discussed with regard to an initial state, a transition state, and an equilibrium state. During the initial state, pump chamber 60 and pressure chamber 70 contain a fluid with an initial pressure that is substantially equal to the ambient pressure of air that surrounds article of footwear 10 and fluid system 20. During the transition state, the pressure within pressure chamber 70 increases from the initial pressure to an equilibrium pressure, at which time fluid system 20 is in the equilibrium state.

- [45] Fluid system 20 is at least partially encapsulated within the polymer foam material of midsole 13. In manufacturing article of footwear 10, fluid system 20 is positioned within a mold having the shape of midsole 13. When fluid system 20 is placed within the mold, fluid system 20 is either in the initial state or the pressure of the fluid within pump chamber 60 and pressure chamber 70 is slightly elevated above the ambient pressure. Accordingly, pump chamber 60 and pressure chamber 70 are in an expanded configuration rather than a collapsed configuration. That is, the fluid places sufficient outward pressure upon polymer layers 21 and 22 to prevent pump chamber 60 and pressure chamber 70 from significantly collapsing. The polymer foam material of midsole 13 is then injected into the mold and around fluid system 20. Upon curing of the polymer foam material, fluid system 20 is securely encapsulated within midsole 13 such that pump chamber 60 and pressure chamber 70 remain in the expanded configuration. Furthermore, the polymer foam material may bond to the exterior surfaces of polymer layers 21 and 22. Midsole 13 is then secured to upper 11 and outsole 14 to form article of footwear 10.
- [46] During the manufacturing process of article of footwear 10, the pressure of the fluid within pump chamber 60 and pressure chamber 70 may be slightly elevated above the ambient pressure, as discussed above. As article of footwear 10 is shipped to retailers or stored, the fluid within fluid system 20 may diffuse through polymer layers 21 and 22 or otherwise escape from fluid system 20 until the pressure of the fluid is substantially equal

to the ambient pressure of air that surrounds article of footwear 10 and fluid system 20. Accordingly, when an individual first places article of footwear 10 upon the foot, fluid system 20 is in the initial state.

- [47] Fluid system 20 may be positioned in the heel region of midsole 13, as depicted in Figures 1 and 2. More particularly, fluid system 20 may be positioned such that pump chamber 60 is positioned directly below the calcaneus bone of the individual wearing article of footwear 10, and pressure chamber 70 is positioned below side portions of the calcaneus bone. When the individual takes a first step in article of footwear 10, sole structure 12 is compressed against the ground, which compresses both midsole 13 and fluid system 20. Based upon the relative positions of the calcaneus bone, pump chamber 60, and pressure chamber 70, pump chamber 60 bears a large portion of the force that causes the compression, and pressure chamber 70 also bears a portion of the force. The compression of pump chamber 60 causes the pressure of the fluid within pump chamber 60 to increase. When a pressure differential between pump chamber 60 and pressure chamber 70 exceeds various pressure losses inherent in fluid system 20, a portion of the fluid within pump chamber 60 passes through conduit 40b and through valve 50b to pass into pressure chamber 70. That is, compressing pump chamber 60 may cause a portion of the fluid within pump chamber 60 to pass into pressure chamber 70. The additional fluid within pressure chamber 70 causes the pressure within pressure chamber 70 to increase. As the individual takes a first step, therefore, fluid system 20 is placed in the transition state due to increases in pressure of both pump chamber 60 and pressure chamber 70. The various pressure losses mentioned above may be associated with friction that occurs as the fluid passes through conduit 40b and an opening pressure of valve 50b.
- [48] Valves 50a and 50b are one-directional valves that permit fluid flow in a first direction, but limit or check fluid flow in an opposite second direction. Valve 50a permits fluid to flow from filter assembly 30 to pump chamber 60, but limits fluid flow in the opposite direction. When pump chamber 60 is compressed, therefore, valve 50a effectively prevents the fluid from flowing to filter assembly 30. Valve 50b, however, permits fluid to flow from pump chamber 60 to pressure chamber 70 when the pressure differential

between pump chamber 60 and pressure chamber 70 exceeds the opening pressure of valve 50b.

[49] As the first step that the individual takes progresses, and the calcaneus bone no longer places a significant force upon midsole 13, the compressive force exerted upon fluid system 20 decreases and midsole 13 returns to an uncompressed configuration. The pressure of the fluid within pressure chamber 70, however, remains elevated and fluid system 20 remains in the transition state. Due to the bonds between the polymer material of midsole 13 and polymer layers 21 and 22, midsole 13 will place an outward force on pump chamber 60 as midsole 13 returns to the uncompressed configuration. That is, the polymer material of midsole 13 will attempt to expand the compressed pump chamber 60. This action causes the pressure within pump chamber 60 to become negative relative to the ambient pressure of the air outside of article of footwear 10 and fluid system 20. Accordingly, a negative pressure differential is formed between pump chamber 60 and the ambient air. Filter assembly 30 and conduit 40a form a fluid path between the ambient air and pump chamber 60. When the negative pressure differential exceeds various pressure losses associated with fluid system 20, ambient air will pass through filter assembly 30, enter conduit 40a, pass through valve 50a, and enter pump chamber 60, thereby placing additional fluid within pump chamber 60. In other words, air will flow into pump chamber 60 as midsole 13 expands from being compressed. The various pressure losses mentioned above may be associated with resistance from filter material 32, friction that occurs as the fluid passes through conduit 40a, and an opening pressure of valve 50a.

[50] The discussion above details the manner in which a first step of the individual compresses pump chamber 60 and causes a portion of the fluid within pump chamber 60 to pass into pressure chamber 70, thereby increasing the pressure within pressure chamber 70. Once the first step is completed and midsole 13 is not being compressed, additional air passes into pump chamber 60 from the ambient air that surrounds article of footwear 10 and fluid system 20. When the individual takes a second step and a plurality of further steps, the process described with respect to the first step repeats and the

pressure of the fluid within pressure chamber 70 increases. Accordingly, fluid system 20 remains in the transition stage as the pressure within pressure chamber 70 rises.

[51] Immediately prior to the first step, the pressure within pump chamber 60 and pressure chamber 70 was substantially equal to the ambient pressure of air. As midsole 13 was compressed, therefore, pump chamber 60 and pressure chamber 70 provided a relatively small degree of support. That is, the pressure of the fluid within pump chamber 60 and pressure chamber 70 was not sufficient to provide a relatively large degree of cushioning. As the individual continues to take steps and the pressure of the fluid within pressure chamber 70 increases, however, the degree of support and cushioning provided by pressure chamber 70 also increases. After a sufficient number of steps, the support provided by pressure chamber 70 prevents pump chamber 60 from being compressed significantly. In other words, the support provided by pressure chamber 70 will limit the degree to which pump chamber 60 is compressed when midsole 13 is compressed. Accordingly, the pressure of the fluid within pressure chamber 70 will eventually balance the compression of pump chamber 60, and fluid system 20 will reach the equilibrium state.

[52] The pressure of the fluid within pressure chamber 70 at the equilibrium state is at least partially a function of the degree to which pressure chamber 70 extends around the side portion of pump chamber 60. For purposes of example, assume pump chamber 60 and pressure chamber 70 are sufficiently separated such that increases in pressure within pressure chamber 70 do not provide support against compressions of pump chamber 60. In this configuration, the maximum pressure of pressure chamber 70 is approximately equal to the maximum pressure that the individual may induce within pump chamber 60. When pressure chamber 70 extends around at least a portion of the side portion of pump chamber 60, however, the increase in pressure of the fluid within pressure chamber 70 provides support against compressing pump chamber 60. As the degree to which pressure chamber 70 extends around pump chamber 60 increases, the amount of support that pressure chamber 70 may provide to resist compressions of pump chamber 60 also increases. For example, if pressure chamber 70 extends only partially around the side portion of pump chamber 60, then portions of pump chamber 60 that are not adjacent to

pressure chamber 70 may remain compressible. If, however, pressure chamber 70 extends entirely around pump chamber 60, then pressure chamber 70 may substantially limit the amount of pump chamber 60 that may be compressed. Accordingly, the pressure of the fluid within pressure chamber 70 is at least partially determined by the degree to which pressure chamber 70 extends around the side portion of pump chamber 60. The pressure of the fluid within pressure chamber 70 is, therefore, effectively limited by extending pressure chamber 70 around at least a portion of pump chamber 60. Other factors that determine the pressure of the fluid within pressure chamber 70 include the relative forces exerted upon pump chamber 60 and pressure chamber 70, the relative dimensions of pump chamber 60 and pressure chamber 70, and the compressibility of the foam material encapsulating fluid system 20, for example.

[53] Pressure chamber 70, as depicted in Figures 3 and 4, forms a generally C-shaped structure with an interior area that accommodates pump chamber 60. In other embodiments of fluid system 20, however, pressure chamber 70 may extend around the side portion of pump chamber 60 to a lesser or greater degree. With reference to Figures 8A and 8B, an alternative embodiment of the present invention is depicted, wherein a fluid system 20' includes a filter assembly 30', a pair of conduits 40a' and 40b', a pair of valves 50a' and 50b', a pump chamber 60', and a pressure chamber 70'. Fluid system 20' has the general configuration of fluid system 20, but end portions of pressure chamber 70' are elongated to form a generally U-shaped structure that forms an interior area for receiving pressure chamber 70' and portions of conduits 40a' and 40b'. Whereas pressure chamber 70 will substantially limit compression of pump chamber 60 when the pressure of the fluid within pressure chamber 70 is relatively high, the extended end portions of pressure chamber 70' may limit compression of pump chamber 60' to a greater degree. In addition, the extended end portions of pressure chamber 70' may limit the compression of other components of fluid system 20', including conduits 40a' and 40b' and valves 50a' and 50b', thereby extending the life of the components.

[54] Pump chamber 60, as depicted in Figures 3 and 4, has a substantially circular configuration. With respect to Figures 9A and 9B, another embodiment of the present invention is depicted, wherein a fluid system 20'' includes a filter assembly 30'', a pair of

conduits 40a'' and 40b'', a pair of valves 50a'' and 50b'', a pump chamber 60'', and a pressure chamber 70''. In contrast with the substantially circular configuration of pump chamber 60, pump chamber 60'' has an elongate configuration. Pressure chamber 70'' also has a U-shaped configuration that forms an interior area for receiving pump chamber 60'' and limiting compression of pump chamber 60''.

[55] Pump chamber 60 is generally positioned such that a top portion 61 of pump chamber 60 does not extend above a top portion 71 of pressure chamber 70. Similarly, a bottom portion 62 of pump chamber 60 does not extend below a bottom portion 72 of pressure chamber 70. Fluid system 20' has a similar configuration, wherein a top portion 61' of pump chamber 60' does not extend above a top portion 71' of pressure chamber 70', and a bottom portion 62' of pump chamber 60' does not extend below a bottom portion 72' of pressure chamber 70'. In contrast with fluid systems 20 and 20', a top portion 61'' of pump chamber 60'' extends above a top portion 71'' of pressure chamber 70'', as depicted in the cross-sectional view of Figure 9B. A bottom portion 62'' of pump chamber 60'' is not depicted, however, as extending below a bottom portion 72'' of pressure chamber 70''. The relative vertical positions of pump chamber 60'' and pressure chamber 70'' have an effect upon the pressure limiting property of fluid system 20''. Even when pressure chamber 70'' is at a maximum pressure, the volume of pump chamber 60'' extending above top portion 71'' of pressure chamber 70'' may be compressed. Pressure chamber 70'' does, however, limit the compressibility of the portion of pump chamber 60'' located at or below top portion 71'' of pressure chamber 70''. Accordingly, the relative vertical positions of pump chambers and pressure chambers may also be utilized to affect the pressure limiting property of a fluid system.

[56] Fluid system 20 may be formed through a thermoforming process that involves heating layers 21 and 22 and utilizing a mold to bond layers 21 and 22 together in the desired locations. Prior to heating layers 21 and 22, valves 50a and 50b may be placed between portions of layers 21 and 22 that will become conduits 40a and 40b. Similarly, filter material 32 may be placed between portions of layers 21 and 22 that will become filter assembly 30. The mold utilized in the thermoforming process may have areas that compress layers 21 and 22 to form bonded areas 23 that define conduits 40a and 40b,

pump chamber 60, and pressure chamber 70. Furthermore, the mold may have cavities configured to receive portions of layers 21 and 22 and define the shapes of conduits 40a and 40b, pump chamber 60, and pressure chamber 70. When bonding layers 21 and 22 together, a fluid may be injected between layers 21 and 22 to press layers 21 and 22 into the various contours of the mold. Similarly, a vacuum may be induced on the exterior of layers 21 and 22 to also draw layers 21 and 22 into the various contours of the mold. Fluid systems 20' and 20'' may also be formed through a similar thermoforming process.

[57] A variety of other processes may be utilized to form fluid system 20, in addition to the thermoforming process described above. For example, layers 21 and 22 may be formed from flat thermoplastic sheets that are bonded together to define conduits 40a and 40b, pump chamber 60, and pressure chamber 70. In addition, layers 21 and 22 may be separately formed to include indentations corresponding with conduits 40a and 40b, pump chamber 60, and pressure chamber 70. Valves 50a and 50b may then be placed between layers 21 and 22, and bonds may be formed to join layers 21 and 22. Furthermore, fluid system 20 or individual components of fluid system 20 may be manufactured through blow molding or rotational molding processes. In situations where individual components of fluid system 20 are formed separately, the individual components may be joined together to form fluid system 20. That is, a bonding technique may be utilized to join conduits 40a and 40b, pump chamber 60, and pressure chamber 70, as described in U.S. Patent Application Serial Number 10/351,876, which was filed January 27, 2003 and is hereby entirely incorporated by reference.

[58] The structure of valve 100 will now be discussed in greater detail. Valve 100 has the general structure of one of a plurality of valves described in U.S. Patent Application Serial Number 10/246,755, which was filed September 19, 2002 and is hereby entirely incorporated by reference. A valve having the structure of valve 100 may be utilized as either or both of valves 50a and 50b to regulate the fluid flow within fluid system 20. Valve 100 may also be utilized as valves 50a', 50b', 50a'', or 50b'' to regulate the fluid flow within fluid systems 20' and 20''. Valve 100 is depicted in Figures 10A-10G and includes a first valve layer 110a and a second valve layer 110b that are positioned between a first substrate layer 120a and a second substrate layer 120b. With respect to

fluid system 20, for example, substrate layers 120 are analogous to polymer layers 21 and 22 that form conduits 40a and 40b. First valve layer 110a and second valve layer 110b are bonded together along opposite sides to form two channel welds 130 and define a channel 140 positioned between valve layers 110 and between channel welds 130. Channel 140 includes an inlet 142 and an outlet 144. Inlet 142 is biased in the open position by two inlet weld beads 146 formed of polymer material that collects in inlet 142 and adjacent to channel welds 130 during the bonding of first valve layer 110a and second valve layer 110b. Outlet 144 is located opposite inlet 142 and may be formed of unbonded portions of valve layers 110. Each valve layer 110 includes an outer surface 112 and an opposite inner surface 114. With regard to valve layer 110a, an outer surface 112a lies adjacent to substrate layer 120a and an inner surface 114a that lies adjacent to valve layer 110b. Similarly, valve layer 110b includes an outer surface 112b that lies adjacent to substrate layer 120b and an opposite inner surface 114b that lies adjacent to valve layer 110a.

- [59] Valve 100 also includes two substrate welds 150 that attach valve layers 110 to substrate layers 120. More specifically, substrate welds 150 attach valve layer 110a to substrate layer 120a and attach valve layer 110b to substrate layer 120b. As depicted in Figures 10, substrate welds 150 are located adjacent to inlet 142. Substrate welds 150 may also be positioned adjacent to other portions of valve 100.
- [60] In operation, valve 100 permits fluid flow through channel 140 and in the direction from inlet 142 to outlet 144. Valve 100, however, significantly limits fluid flow in the opposite direction. As noted, inlet weld beads 146 bias inlet 142 in the open position. This configuration ensures that the fluid in conduit 30 may enter at least the portion of channel 140 formed by inlet 142. The primary factor that determines whether the fluid may pass through valve 100 is the relative difference in pressure between the fluid in inlet 142 and the fluid at outlet 144. When the pressure of the fluid in inlet 142 exceeds the pressure of the fluid at outlet 144 plus an opening pressure of valve 100, the force that the fluid in inlet 142 exerts on inner surfaces 114 of valve layers 110 is sufficient to overcome the force that the fluid at outlet 144 exerts on outer surfaces 112, thereby permitting valve layers 110 to separate. When valve layers 110 separate, fluid may pass

through channel 140. When the pressure of the fluid in inlet 142 is less than the pressure of the fluid at outlet 144, however, the force that the fluid in inlet 142 exerts on inner surfaces 114 of valve layers 110 is not sufficient to overcome the force that the fluid at outlet 142 exerts on outer surfaces 112, thereby preventing valve layers 110 from separating. When valve layers 110 are not separated, channel 140 is effectively closed to fluid transfer.

- [61] Outlet 144 assists in preventing the passage of fluid through valve 100 by ensuring that valve layers 110 make a hermetic contact. Note that channel welds 130 may extend less than the entire length of valve layers 110. Accordingly, outlet 144 may include unbonded portions of valve layers 110. The lack of bonds at outlet 144 permits unobstructed closure at outlet 144, thereby providing the hermetic contact between valve layers 110 that prevents fluid from passing between valve layers 110. Inner surfaces 114 may include a smooth, cohesive surface that facilitates closure of valve 100. Accordingly, the characteristics of inner surfaces 114 may also contribute to the hermetic contact and facilitate one-directional fluid flow through valve 100.
- [62] The materials forming valve layers 110 and substrate layers 120 should possess several characteristics. First, the materials should permit welds 130 and 150 to securely form between the various material layers using standard techniques, such as thermal contact, RF energy, laser, and infrared welding. Second, the materials should also be substantially impermeable to fluids, such as air. Third, the materials should possess sufficient flexibility to permit valve 100 to operate as described above. Fourth, the materials should possess a durability that permits valve 100 to operate through numerous cycles. Fifth, the materials may be chosen to resist hydrolysis, or chemical breakdown due to the presence of water, if water or water vapor may be present around valve 100. Based upon these considerations, suitable materials include thermoplastic polyurethane, urethane, polyvinyl chloride, and polyethylene. When valve 100 is formed of thermoplastic polyurethane, a suitable thickness for valve layers 110 is 0.018 inches, but may range from 0.004 inches to 0.035 inches, for example. Similarly, a suitable thickness for substrate layers 120 is 0.030 inches, but may range from 0.015 inches to 0.050 inches, for example. The thickness of valve layers 110 and the thickness of

substrate layers 120 may depart from the ranges listed above, however, depending upon the specific application for valve 100, the materials and manufacturing methods utilized, and the properties that valve 100 is intended to impart to the fluid system.

- [63] A benefit to locating substrate welds 150 adjacent to inlet 142 lies in the relatively large area of outer surfaces 112 that are exposed to the fluid at outlet 144. As noted above, when the pressure of the fluid in inlet 142 is less than the pressure of the fluid at outlet 144, the force that the fluid in inlet 142 exerts on inner surface 114 of valve layers 110 is not sufficient to overcome the force that the fluid at outlet 144 exerts on outer surfaces 112, thereby preventing valve layers 110 from separating and preventing the flow of fluid through valve 100. By configuring the position of valve layers 110 such that a relatively large area of outer surfaces 112 are exposed to the fluid at outlet 144, the area of contact between inner surfaces 114 increases proportionally. The primary mechanism that prevents fluid from passing through valve 100 is the hermetic contact properties of inner surfaces 114. Accordingly, increased efficiency is achieved by having a relatively large portion of outer surfaces 112 exposed to the fluid at outlet 144.
- [64] As an alternative, valve 100 may be formed from a single valve layer 110 that is bonded with one of the substrate layers 120 to form channel welds 130. Accordingly, channel 140 may be formed between channel welds 130 and between the valve layer 110 and the substrate layer 120. The alternative valve 100 operates in a manner that is substantially similar to the operation of valve 100. In addition, valve 100 may be formed such that channel welds 130 extend around and enclose outlet 144. An aperture may then be formed in one of valve layers 110 to permit the fluid to pass through valve 100. In either alternative embodiment, contact between valve layer 110 and the substrate layer 120 effectively closes valve 100.
- [65] As discussed above, when the pressure of the fluid in inlet 142 is less than the pressure of the fluid at outlet 144, the force that the fluid in inlet 142 exerts on inner surfaces 114 of valve layers 110 is not sufficient to overcome the force that the fluid at outlet 142 exerts on outer surfaces 112, thereby preventing valve layers 110 from separating. When valve layers 110 are not separated, channel 140 is effectively closed to fluid transfer. If,

however, particulates are positioned within valve 100 and between valve layers 110, the fluid may be able to pass through valve 100 in the direction of outlet 144 to inlet 142. That is, the effectiveness of valve 100 in preventing fluid transfer in the direction from outlet 144 to inlet 142 may be compromised by the presence of particulates 74.

[66] The present invention is disclosed above and in the accompanying drawings with reference to a variety of embodiments. The purpose served by the disclosure, however, is to provide an example of the various features and concepts related to the invention, not to limit the scope of the invention. One skilled in the relevant art will recognize that numerous variations and modifications may be made to the embodiments described above without departing from the scope of the present invention, as defined by the appended claims.

CLAIMS

That which is claimed is:

1. A fluid system for an article of footwear, the fluid system comprising:
a first chamber having a side portion, a top portion, and a bottom portion;
a second chamber extending at least partially around the side portion of the first chamber,
and the second chamber extending above the top portion of the first chamber;
a fluid path extending between the first chamber and the second chamber to place the first
chamber and the second chamber in fluid communication; and
a valve positioned within the fluid path to permit fluid flow from the first chamber to the
second chamber and to substantially prevent fluid flow from the second chamber
to the first chamber.
2. The fluid system recited in claim 1, wherein the second chamber has a curved
configuration that defines an interior area within the curved configuration, the first chamber
being positioned within the interior area.
3. The fluid system recited in claim 1, wherein two coextensive sheets of polymer material
are bonded together to form the first chamber, the second chamber, and the fluid path.
4. The fluid system recited in claim 3, wherein the valve is positioned between the sheets of
polymer material.
5. The fluid system recited in claim 3, wherein the fluid system is formed through a
thermoforming process.
6. The fluid system recited in claim 1, wherein the valve is formed from at least one layer of
polymer material.
7. The fluid system recited in claim 1, wherein the valve includes an inlet that is biased
open with at least one weld bead positioned within the inlet.

8. The fluid system recited in claim 1, wherein another fluid path with a filter assembly extends from an exterior of the fluid system to the first chamber to place the first chamber in fluid communication with the exterior of the footwear.
9. The fluid system recited in claim 8, wherein the filter assembly includes a filter material that permits air to enter the fluid system and restricts liquids and particulates from entering the fluid system.
10. The fluid system recited in claim 9, wherein the filter material includes a polytetrafluoroethylene material.
11. The fluid system recited in claim 1, wherein the fluid path consists of a conduit and the valve.
12. The fluid system recited in claim 1, wherein a fluid inlet for the fluid system is in fluid communication with the first chamber, the fluid inlet being separate from the first chamber.
13. The fluid system recited in claim 1, wherein the second chamber extends below the bottom portion of the first chamber.
14. An article of footwear having an upper and a sole structure, the sole structure comprising:
 - a polymer foam material; and
 - a fluid system at least partially encapsulated within the polymer foam material, the fluid system including:
 - a pump chamber having a side portion, a top portion, and a bottom portion;
 - a pressure chamber extending at least partially around the side portion of the pump chamber, and the pressure chamber extending above the top portion of the pump chamber;
 - a first fluid path extending between the pump chamber and the pressure chamber to place the pump chamber and the pressure chamber in fluid communication,

- a first valve positioned within the first fluid path to permit fluid flow from the pump chamber to the pressure chamber and to limit fluid flow from the pressure chamber to the pump chamber,
- a second fluid path extending from an exterior of the footwear to the pump chamber to place the pump chamber in fluid communication with the exterior of the footwear, and
- a second valve positioned within the second fluid path to permit fluid flow from the exterior to the pump chamber and to limit fluid flow from the pump chamber to the exterior.

15. The article of footwear recited in claim 14, wherein the pressure chamber has a curved configuration that defines an interior area within the curved configuration, the pump chamber being positioned within the interior area.

16. The article of footwear recited in claim 14, wherein two coextensive sheets of polymer material are bonded together to form the pump chamber, the pressure chamber, the first fluid path, and the second fluid path.

17. The article of footwear recited in claim 16, wherein the first valve and the second valve are positioned between the sheets of polymer material.

18. The article of footwear recited in claim 16, wherein the fluid system is formed through a thermoforming process.

19. The article of footwear recited in claim 14, wherein each of the first valve and the second valve is formed from at least one layer of polymer material.

20. The article of footwear recited in claim 14, wherein a filter is positioned in the second fluid path.

21. The article of footwear recited in claim 20, wherein the filter includes a filter material that permits air to enter the fluid system and restricts liquids and particulates from entering the fluid system.
22. The article of footwear recited in claim 14, wherein the pressure chamber extends below the bottom portion of the pump chamber.
23. The article of footwear recited in claim 14, wherein the first fluid path and the second fluid path are conduits.
24. The article of footwear recited in claim 14, wherein the second fluid path consists of a conduit and the second valve.
25. The article of footwear recited in claim 14, wherein a fluid inlet for the fluid system is positioned separate from the pump chamber.
26. A fluid system for an article of footwear, the fluid system comprising:
 - a first sheet formed of a thermoplastic polymer material;
 - a second sheet of the thermoplastic material, the first sheet and the second sheet being bonded together to define:
 - a first chamber,
 - a second chamber extending around at least a portion of the first chamber, and
 - a fluid path extending between the first chamber and the second chamber to place the first chamber and the second chamber in fluid communication; and
 - a valve positioned between the first sheet and the second sheet and within the fluid path to permit fluid flow from the first chamber to the second chamber and to limit fluid flow from the second chamber to the first chamber.
27. The fluid system recited in claim 26, wherein the second chamber has a curved configuration that defines an interior area within the curved configuration, the first chamber being positioned within the interior area.

28. The fluid system recited in claim 26, wherein the first chamber has a side portion, a top portion, and a bottom portion, and the second chamber extends above the top portion and below the bottom portion of the first chamber.
29. The fluid system recited in claim 26, wherein a top portion of the first chamber extends above the second chamber.
30. The fluid system recited in claim 26, wherein the valve is formed from at least one layer of polymer material.
31. The fluid system recited in claim 26, wherein the valve includes an inlet that is biased open with at least one weld bead positioned within the inlet.
32. The fluid system recited in claim 26, wherein another fluid path with a filter assembly extends from an exterior of the fluid system to the first chamber to place the first chamber in fluid communication with the exterior of the footwear.
33. The fluid system recited in claim 32, wherein the filter assembly includes a filter material that permits air to enter the fluid system and restricts liquids and particulates from entering the fluid system.
34. The fluid system recited in claim 33, wherein the filter material includes a polytetrafluoroethylene material.
35. The fluid system recited in claim 26, wherein the fluid system is formed through a thermoforming process.
36. The fluid system recited in claim 26, wherein the fluid path consists of a conduit and the valve.

37. The fluid system recited in claim 26, wherein a fluid inlet for the fluid system is in fluid communication with the first chamber, the fluid inlet being separate from the first chamber.
38. An article of footwear having an upper and a sole structure, the sole structure comprising:
a polymer foam material; and
a fluid system at least partially encapsulated within the polymer foam material, the fluid system including:
a first chamber;
a second chamber extending at least partially around a side portion of the first chamber;
a fluid path extending between the first chamber and the second chamber to place the first chamber and the second chamber in fluid communication;
a valve positioned within the fluid path to permit fluid flow from the first chamber to the second chamber and to substantially prevent fluid flow from the second chamber to the first chamber; and
a fluid inlet for the fluid system that is in fluid communication with the first chamber, the fluid inlet being separate from the first chamber.
39. The article of footwear recited in claim 38, wherein the second chamber has a curved configuration that defines an interior area within the curved configuration, the first chamber being positioned within the interior area.
40. The article of footwear recited in claim 38, wherein two coextensive sheets of polymer material are bonded together to form the first chamber, the second chamber, and the fluid path.
41. The article of footwear recited in claim 40, wherein the valve is positioned between the sheets of polymer material.
42. The article of footwear recited in claim 40, wherein the fluid system is formed through a thermoforming process.

43. The article of footwear recited in claim 38, wherein the valve is formed from at least one layer of polymer material.
44. The article of footwear recited in claim 38, wherein the fluid path consists of a conduit and the valve.
45. The article of footwear recited in claim 38, wherein a fluid inlet for the fluid system is in fluid communication with the first chamber, the fluid inlet being separate from the first chamber.
46. The article of footwear recited in claim 38, wherein the first chamber has a side portion, a top portion, and a bottom portion, and the second chamber extends above the top portion and below the bottom portion of the first chamber.
47. The article of footwear recited in claim 38, wherein a top portion of the first chamber extends above the second chamber.
48. A fluid system for an article of footwear, the fluid system comprising:
a pump chamber;
a pressure chamber extending at least partially around a side portion of the pump chamber;
a fluid path extending between the pump chamber and the pressure chamber to place the pump chamber and the pressure chamber in fluid communication, the fluid path consisting of a conduit and a valve positioned within the conduit, the valve permitting fluid flow from the pump chamber to the pressure chamber and substantially preventing fluid flow from the pressure chamber to the pump chamber.
49. The fluid system recited in claim 48, wherein the pressure chamber has a curved configuration that defines an interior area within the curved configuration, the pump chamber being positioned within the interior area.

50. The fluid system recited in claim 48, wherein two coextensive sheets of polymer material are bonded together to form the pump chamber, the pressure chamber, and the fluid path.
51. The fluid system recited in claim 50, wherein the valve is positioned between the sheets of polymer material.
52. The fluid system recited in claim 48, wherein another fluid path with a filter assembly extends from an exterior of the fluid system to the pump chamber to place the pump chamber in fluid communication with the exterior of the footwear.
53. The fluid system recited in claim 48, wherein a fluid inlet for the fluid system is in fluid communication with the pump chamber, the fluid inlet being separate from the pump chamber.

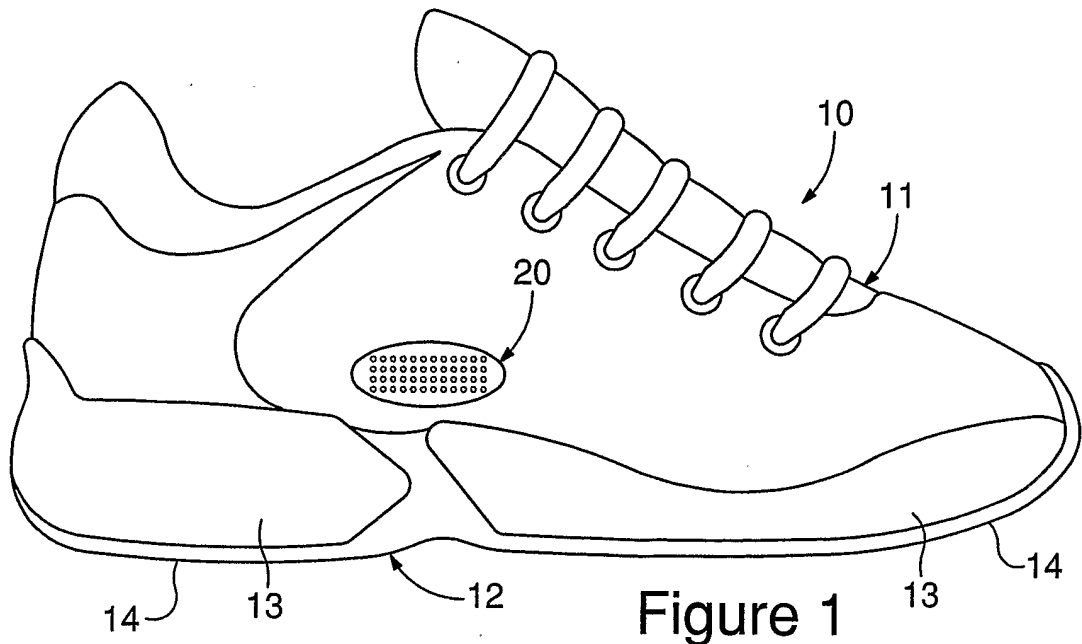

Figure 1

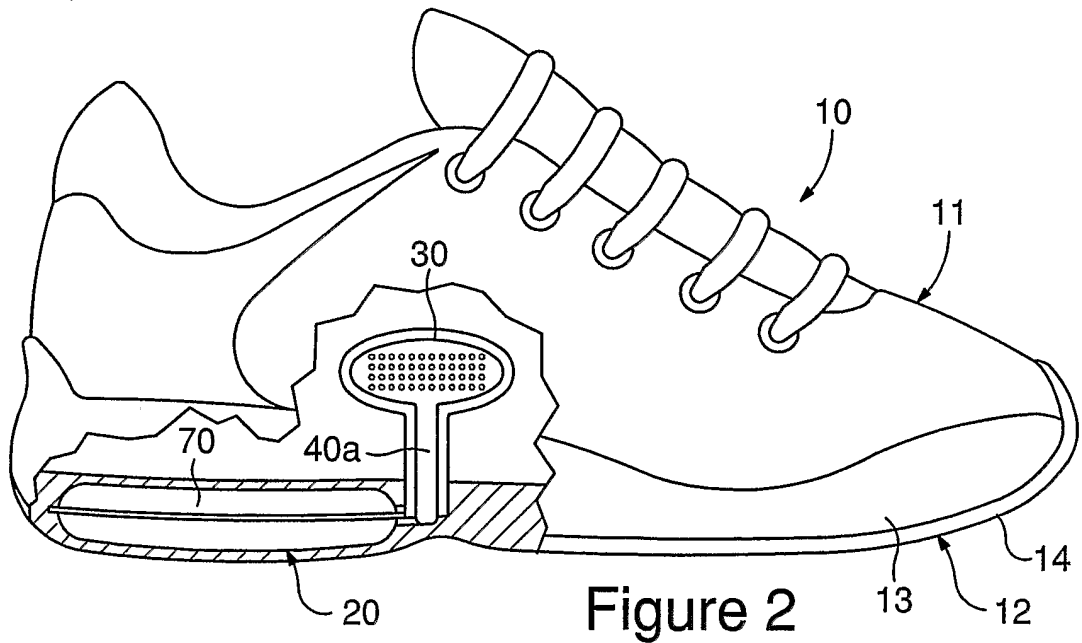
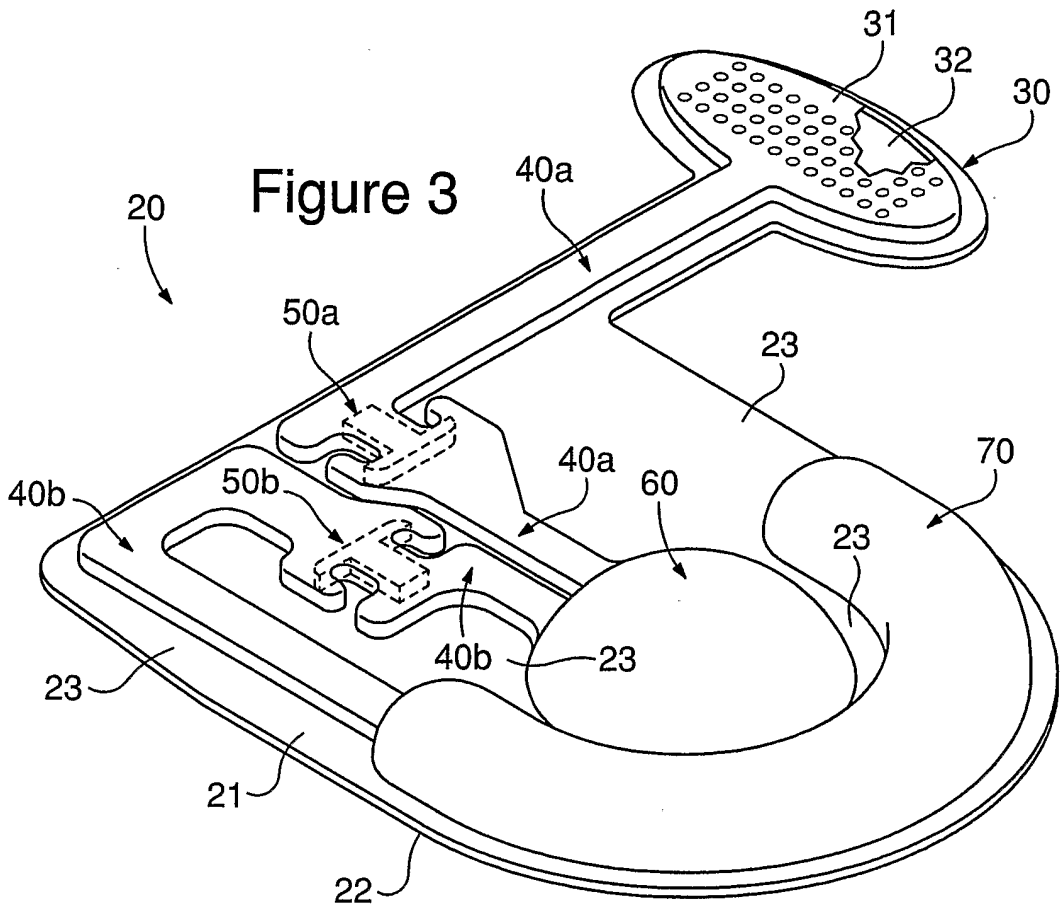

Figure 2



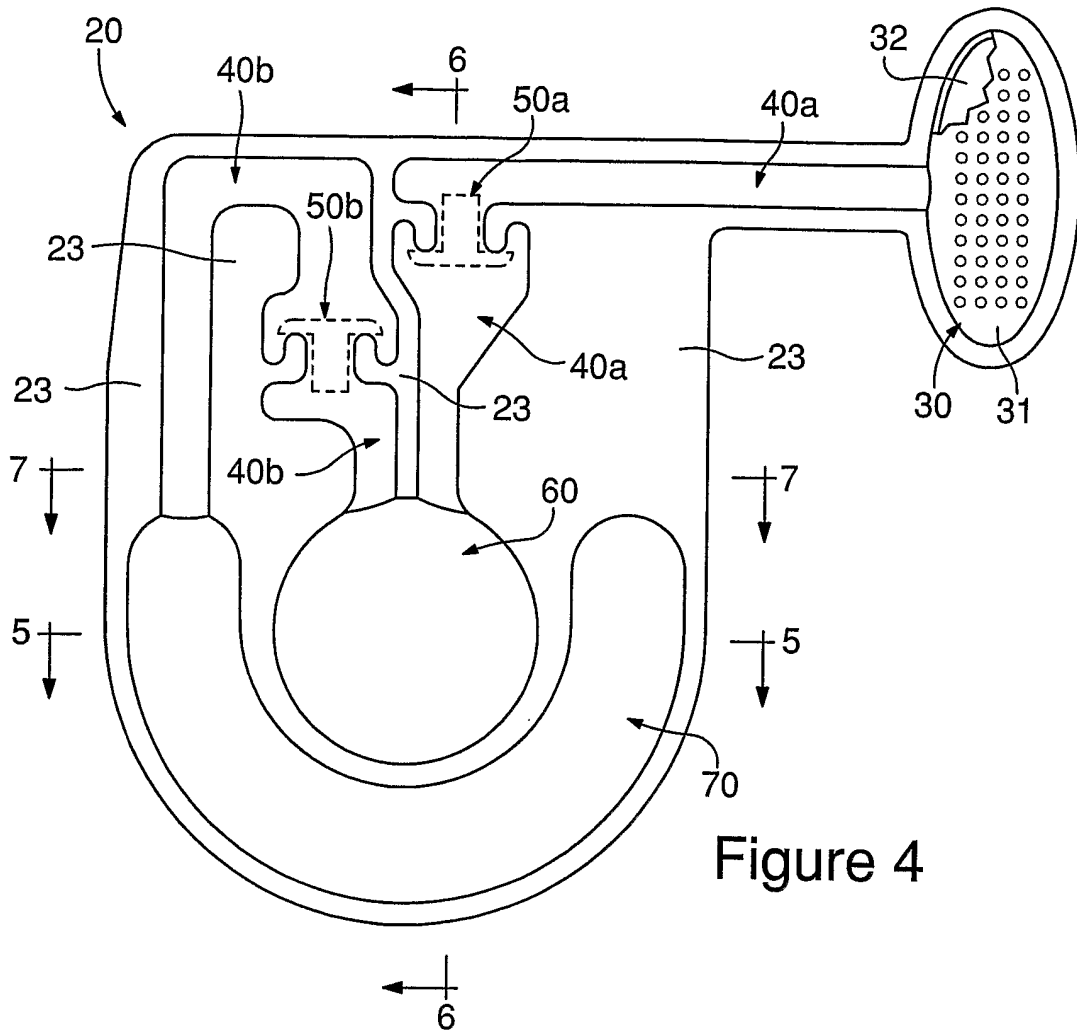

Figure 4

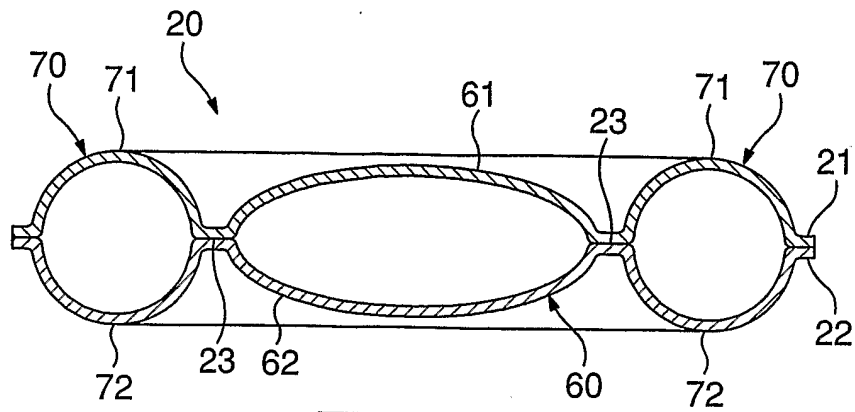

Figure 5

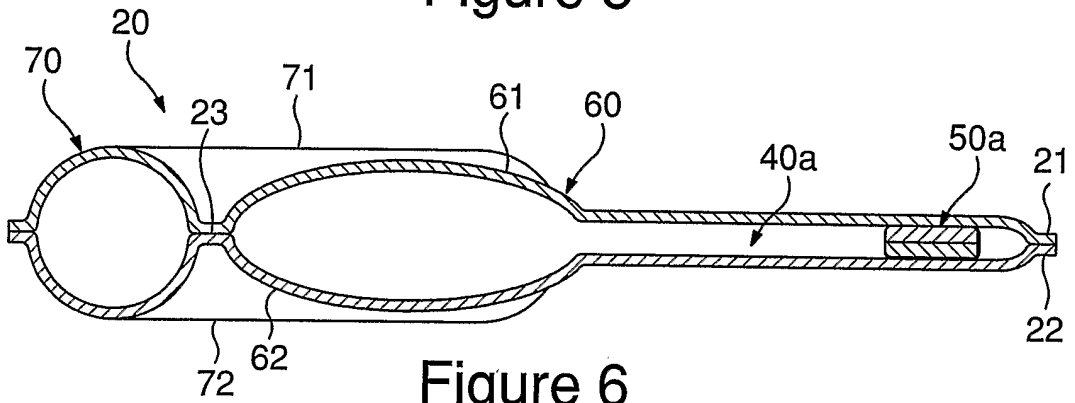

Figure 6

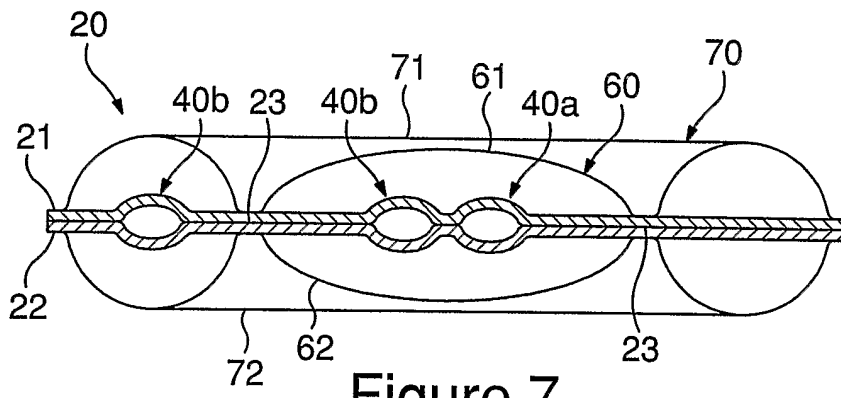

Figure 7

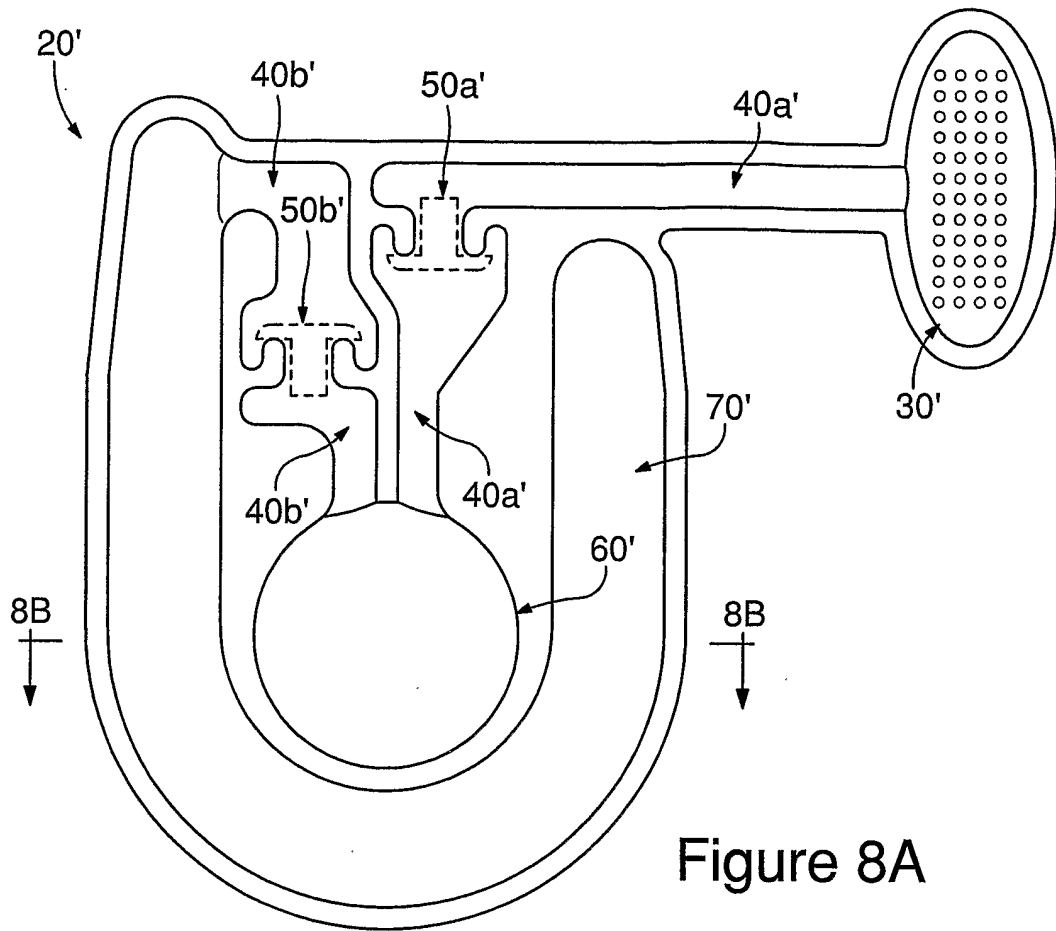

Figure 8A

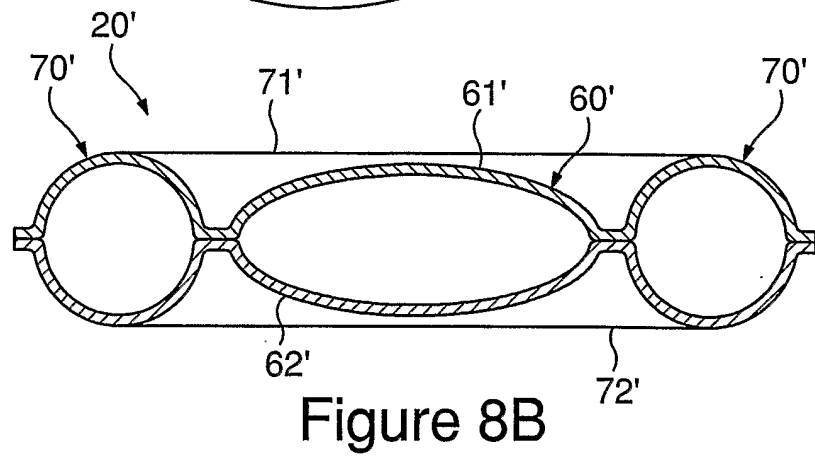

Figure 8B

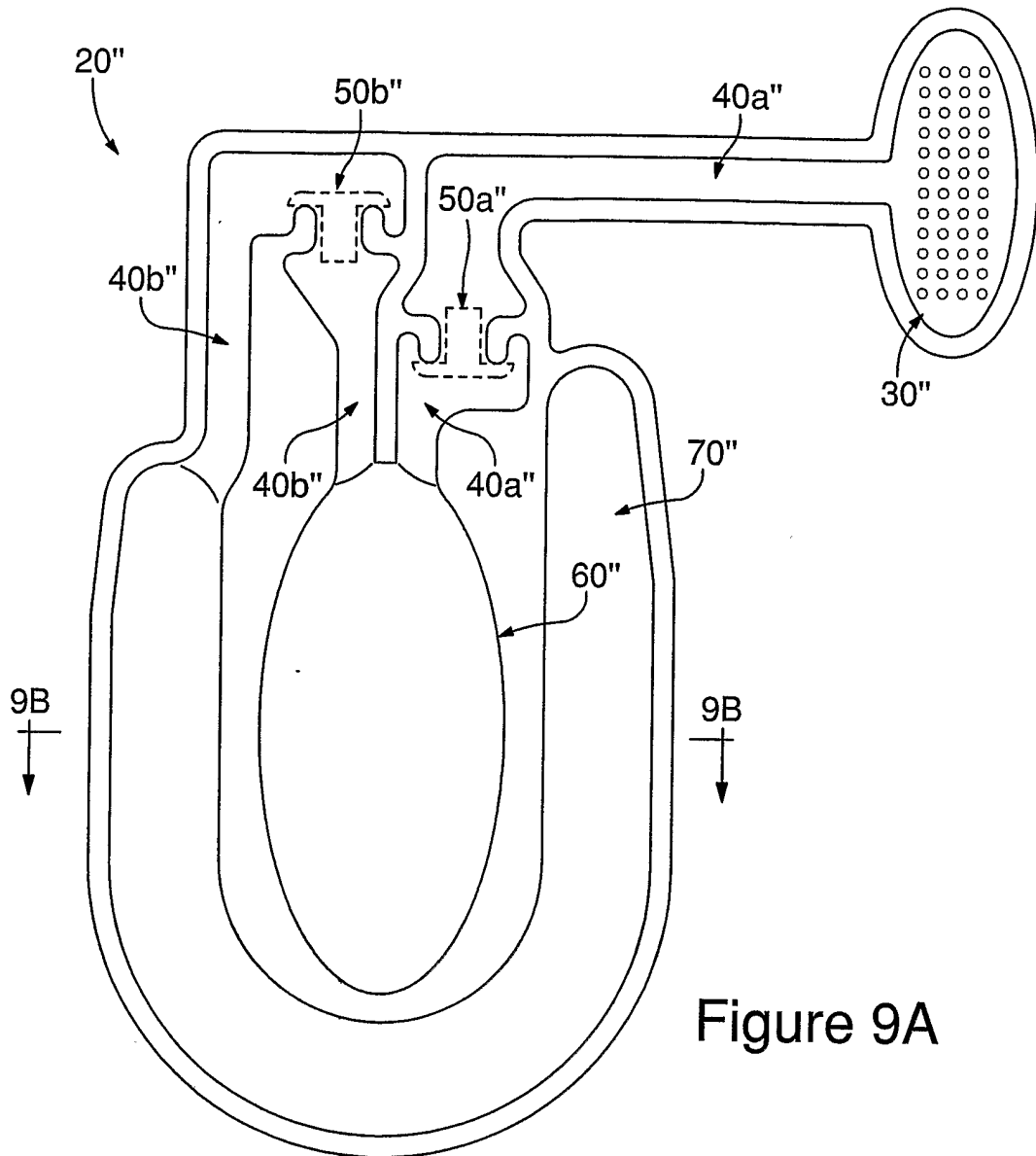

Figure 9A

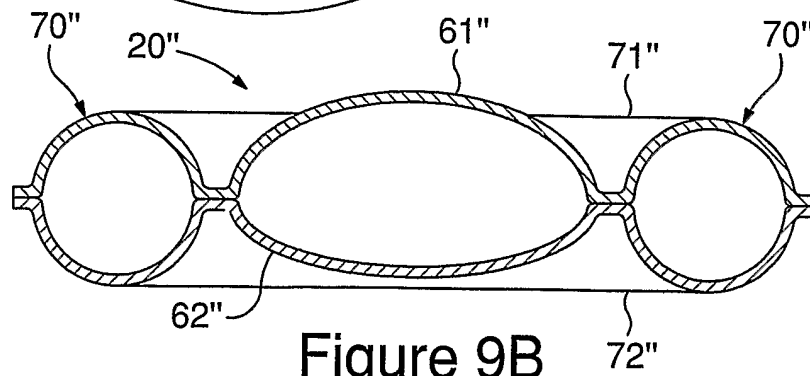

Figure 9B

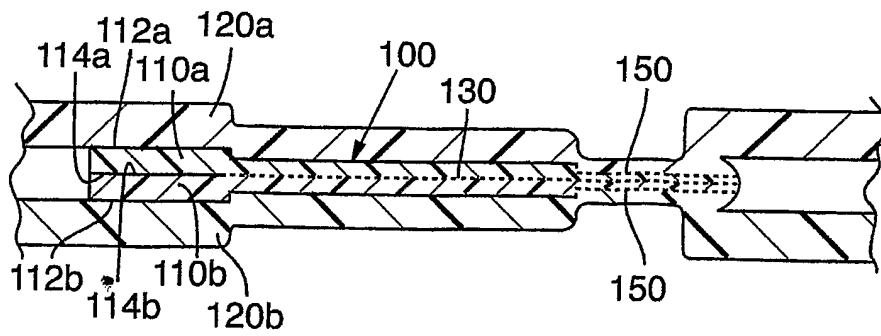

Figure 10B

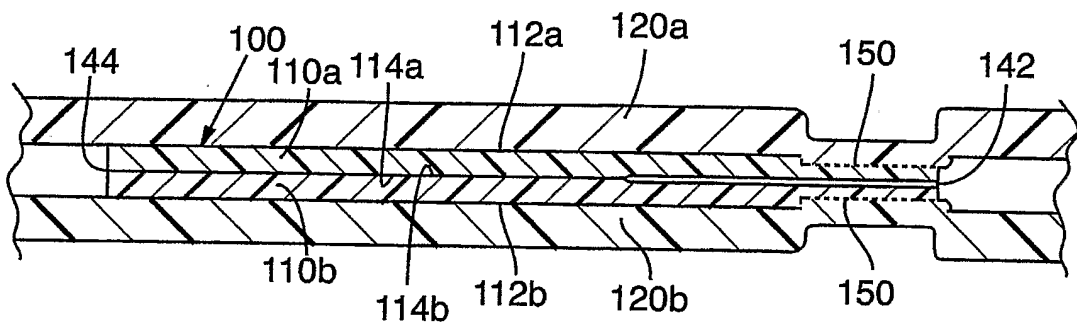

Figure 10C

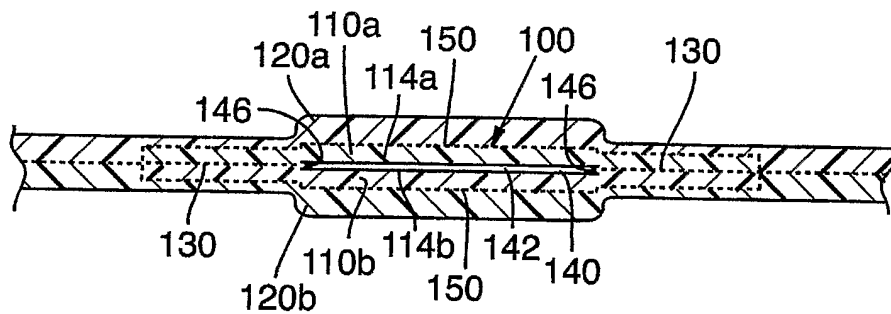

Figure 10D

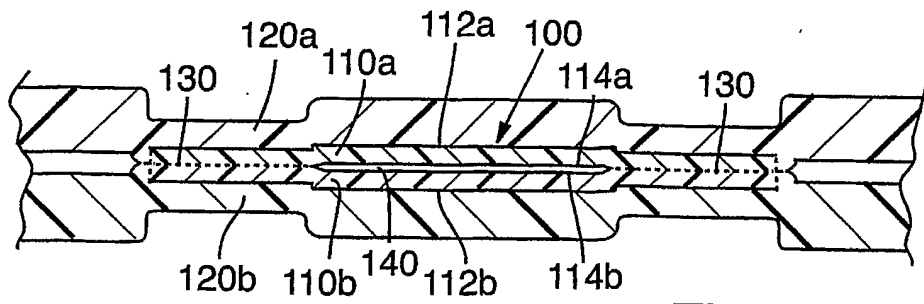

Figure 10E

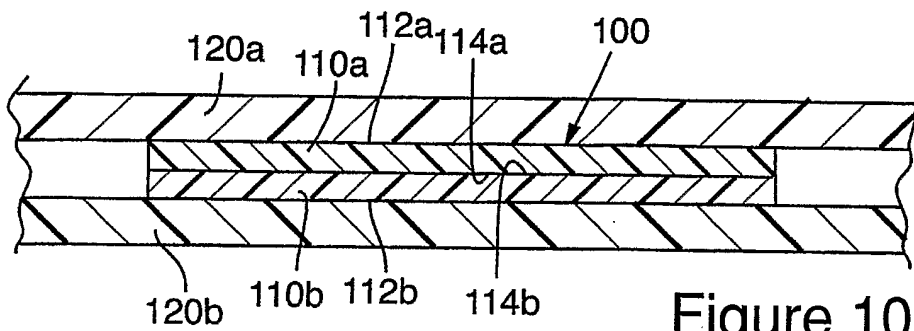

Figure 10F

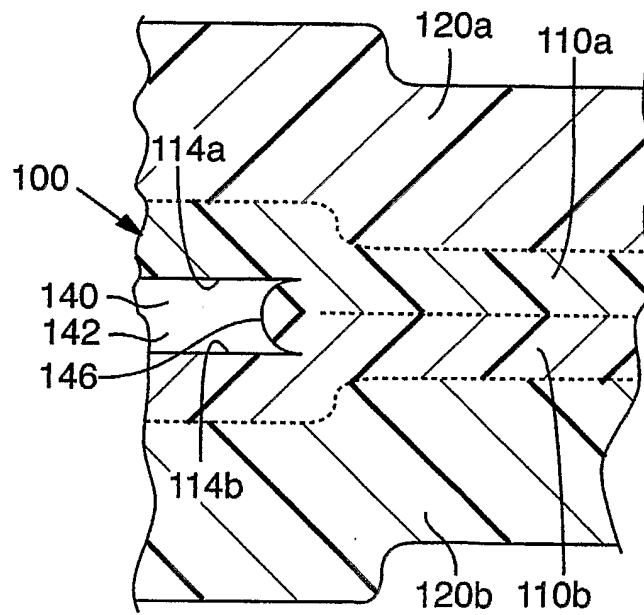

Figure 10G

INTERNATIONAL SEARCH REPORT

In nal Application No
PCT/US2004/017434

A. CLASSIFICATION OF SUBJECT MATTER
 IPC 7 A43B13/20 A43B17/03 A43B21/28

According to International Patent Classification (IPC) or to both national classification and IPC

B. FIELDS SEARCHED

Minimum documentation searched (classification system followed by classification symbols)
 IPC 7 A43B

Documentation searched other than minimum documentation to the extent that such documents are included in the fields searched

Electronic data base consulted during the international search (name of data base and, where practical, search terms used)
 EPO-Internal, WPI Data, PAJ

C. DOCUMENTS CONSIDERED TO BE RELEVANT

Category °	Citation of document, with indication, where appropriate, of the relevant passages	Relevant to claim No.
Y	WO 98/57560 A (HUANG ING CHUNG; CHEN CHUNG CHIN) 23 December 1998 (1998-12-23) page 4, line 4 - page 6, line 14; figures 1,3,4a,4b -----	1-6, 8-30, 32-53
Y	US 2002/194747 A1 (HAZENBERG K PETER ET AL) 26 December 2002 (2002-12-26) paragraph '0022! - paragraph '0046!; figures 1-4,5a,5b paragraph '0048! - paragraph '0050! ----- -/--	1-6, 8-30, 32-53

Further documents are listed in the continuation of box C. Patent family members are listed in annex.

° Special categories of cited documents :

<p>*A* document defining the general state of the art which is not considered to be of particular relevance</p> <p>*E* earlier document but published on or after the international filing date</p> <p>*L* document which may throw doubts on priority claim(s) or which is cited to establish the publication date of another citation or other special reason (as specified)</p> <p>*O* document referring to an oral disclosure, use, exhibition or other means</p> <p>*P* document published prior to the international filing date but later than the priority date claimed</p>	<p>*T* later document published after the international filing date or priority date and not in conflict with the application but cited to understand the principle or theory underlying the invention</p> <p>*X* document of particular relevance; the claimed invention cannot be considered novel or cannot be considered to involve an inventive step when the document is taken alone</p> <p>*Y* document of particular relevance; the claimed invention cannot be considered to involve an inventive step when the document is combined with one or more other such documents, such combination being obvious to a person skilled in the art.</p> <p>*&* document member of the same patent family</p>
--	--

Date of the actual completion of the international search 1 November 2004	Date of mailing of the international search report 08/11/2004
---	---

Name and mailing address of the ISA European Patent Office, P.B. 5818 Patentlaan 2 NL - 2280 HV Rijswijk Tel. (+31-70) 340-2040, Tx. 31 651 epo nl, Fax: (+31-70) 340-3016	Authorized officer Cianci, S
--	--

INTERNATIONAL SEARCH REPORT

In International Application No
PCT/US2004/017434

C.(Continuation) DOCUMENTS CONSIDERED TO BE RELEVANT

Category °	Citation of document, with indication, where appropriate, of the relevant passages	Relevant to claim No.
X	US 2003/084593 A1 (LAKIC NIKOLA) 8 May 2003 (2003-05-08) paragraph '0079! - paragraph '0081!; figures 26-34 -----	1, 2, 11, 12, 14, 15, 23-29, 36-39, 44, 45, 47-49, 53
A	US 2002/035794 A1 (DOYLE HAROLD S) 28 March 2002 (2002-03-28) the whole document -----	1-53

INTERNATIONAL SEARCH REPORT

In International Application No
PCT/US2004/017434

Patent document cited in search report		Publication date	Patent family member(s)	Publication date
WO 9857560	A	23-12-1998	AT 273629 T	15-09-2004
			AU 740251 B2	01-11-2001
			AU 4494397 A	04-01-1999
			BR 9714773 A	25-07-2000
			CA 2294017 A1	23-12-1998
			CN 1262604 A ,C	09-08-2000
			DE 69730359 D1	23-09-2004
			EP 0994659 A1	26-04-2000
			JP 2002504004 T	05-02-2002
			RU 2193857 C2	10-12-2002
			WO 9857560 A1	23-12-1998
US 2002194747	A1	26-12-2002	CA 2450944 A1	03-01-2003
			EP 1397056 A1	17-03-2004
			WO 03000083 A1	03-01-2003
US 2003084593	A1	08-05-2003	US 6510624 B1	28-01-2003
US 2002035794	A1	28-03-2002	US 6305102 B1	23-10-2001
			BR 0213500 A	24-08-2004
			CA 2463366 A1	01-05-2003
			EP 1437951 A1	21-07-2004
			WO 03034856 A1	01-05-2003
			AU 8566798 A	21-12-1998
			WO 9854996 A1	10-12-1998