



(43) International Publication Date  
22 November 2012 (22.11.2012)

- (51) International Patent Classification:  
A61B 1/00 (2006.01) A61B 6/00 (2006.01)
- (21) International Application Number:  
PCT/US2012/038442
- (22) International Filing Date:  
17 May 2012 (17.05.2012)
- (25) Filing Language: English
- (26) Publication Language: English
- (30) Priority Data:  
61/487,058 17 May 2011 (17.05.2011) US
- (72) Inventor; and
- (71) Applicant : AMMIRATI, Mario [US/US]; 1 Miranova Place, Suite 705, Columbus, OH 43215 (US).
- (74) Agent: THE BELLES GROUP, PC; 404 S. 16th Street, Philadelphia, PA 19146 (US).
- (81) Designated States (unless otherwise indicated, for every kind of national protection available): AE, AG, AL, AM, AO, AT, AU, AZ, BA, BB, BG, BH, BR, BW, BY, BZ,

CA, CH, CL, CN, CO, CR, CU, CZ, DE, DK, DM, DO, DZ, EC, EE, EG, ES, FI, GB, GD, GE, GH, GM, GT, HN, HR, HU, ID, IL, IN, IS, JP, KE, KG, KM, KN, KP, KR, KZ, LA, LC, LK, LR, LS, LT, LU, LY, MA, MD, ME, MG, MK, MN, MW, MX, MY, MZ, NA, NG, NI, NO, NZ, OM, PE, PG, PH, PL, PT, QA, RO, RS, RU, RW, SC, SD, SE, SG, SK, SL, SM, ST, SV, SY, TH, TJ, TM, TN, TR, TT, TZ, UA, UG, US, UZ, VC, VN, ZA, ZM, ZW.

(84) Designated States (unless otherwise indicated, for every kind of regional protection available): ARIPO (BW, GH, GM, KE, LR, LS, MW, MZ, NA, RW, SD, SL, SZ, TZ, UG, ZM, ZW), Eurasian (AM, AZ, BY, KG, KZ, RU, TJ, TM), European (AL, AT, BE, BG, CH, CY, CZ, DE, DK, EE, ES, FI, FR, GB, GR, HR, HU, IE, IS, IT, LT, LU, LV, MC, MK, MT, NL, NO, PL, PT, RO, RS, SE, SI, SK, SM, TR), OAPI (BF, BJ, CF, CG, CI, CM, GA, GN, GQ, GW, ML, MR, NE, SN, TD, TG).

Published:  
— without international search report and to be republished upon receipt of that report (Rule 48.2(g))

WO 2012/158971 A2

(54) Title: METHOD AND APPARATUS FOR DELIVERING AN ENDOSCOPE VIA MICROSURGICAL INSTRUMENTS WHILE PERFORMING MICROSCOPIC

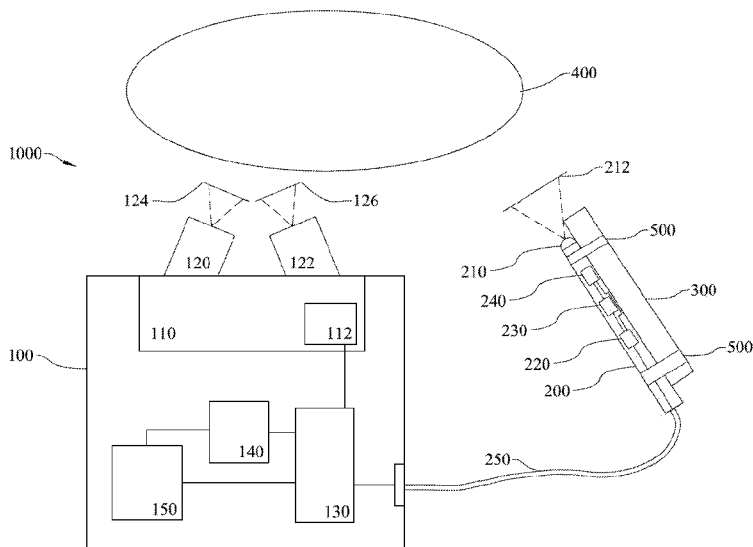

FIGURE 1

(57) Abstract: The present invention relates to a surgical apparatus that includes a surgical instrument including an elongated shaft extending along a longitudinal axis from a proximal end to a distal end, a working element coupled to the distal end of the elongated shaft for manipulating tissue; an endoscope having a tubular body including an image fiber, an endoscopic lens coupled to a distal end of the tubular body and operably coupled to the image fiber, the endoscopic lens defining a viewing field about a central axis; and the endoscope mounted to the elongated shaft of the surgical instrument, the endoscopic lens protruding from an outer longitudinal surface of the elongated shaft the central axis of the viewing field being oblique to the longitudinal axis of the elongated shaft and intersecting the outer longitudinal surface, the working element located within the viewing field and separated from the central axis by a distance.

**METHOD AND APPARATUS FOR DELIVERING AN ENDOSCOPE VIA  
MICROSURGICAL INSTRUMENTS WHILE PERFORMING MICROSCOPIC  
SURGERY**

**Cross-Reference to Related Patent Applications**

[0001] The present application claims the benefit of United States Provisional Patent Application Serial No. 61/487,058, filed May 17, 2011, the entirety of which is incorporated herein by reference.

**Field of the Invention**

[0002] The present invention relates to instruments and methods for minimally invasive microsurgical procedures and treatment of diseases using microscopic and endoscopic combination.

**Background of the Invention**

[0003] Endoscopic surgery is performed by inserting the endoscope into a body cavity. The endoscopic image is displayed on its own monitor. The endoscope has its own carrier that may house other channels to accommodate surgical instruments, irrigation and suction. The endoscope provides wide angle view, the ability to look around the corner and enhanced illumination by bringing the light close to the target; all these features are desirable during surgical procedures. However, the main drawback of purely endoscopic surgery is the lack of 3-D viewing capability. In fact, many patient accidents during endoscopic procedures across all specialties are attributed to lack of a three-dimensional visualization. All these pluses and minuses apply to the use of the endoscope in all different types of surgeries including neurosurgical procedures. In the last 10-15 years there has been an increased use of the endoscope in neurosurgical procedures. If a neurosurgeon wants to use the endoscope, he/she must go through a course and learn a new surgical technique, the endoscopic technique.

[0004] Microscopic surgery, on the other side, is a technique generally known by all neurosurgeons and both spinal and intracranial neurosurgery is often performed with the aid of an operating microscope that allows great illumination and 3-D vision in a narrow operating space. Indeed there is virtually no hospital - small or big, community or academic - where neurosurgery is performed that does not have an operating microscope that gets upgraded or even changed every couple of years.

[0005] It would be desirable to be able to use the unique advantages of the endoscope and to combine them with established microsurgical techniques. A need exists to combine the beneficial uses of the endoscope to augment many microscopic neurosurgical procedures such as vascular, tumor and spinal procedures, yet no combination exists.

#### **Summary of the Invention**

[0006] It is therefore an object of the invention to provide an endoscope/microscope combination that would make the heavily discussed controversy between proponent of the microscope and of the endoscope (see for example the heated controversy between proponents of endoscopic pituitary surgery versus proponents of microscopic pituitary surgery) obsolete and irrelevant. Such endoscope/microscope combination requires the development of a process/platform that would make this combination doable with minimal disruption to established microsurgical techniques.

[0007] This new platform has the potential to become what Laparoscopy represented for General Surgery, Ob-Gyn, and several other specialties in the early 1990's, namely a complete revolution not only for the doctors, but also for organizations that had the vision to invest and enter into the very beginning of this market.

[0008] Therefore, it is an object of the present invention to provide a process where about microsurgical instruments become the endoscope carriers.

[0009] Another object of the invention is the use of a device that allows the attachment of the endoscope to the microsurgical instrument.

[0010] It is still another object of the invention some dedicated micro-instruments specifically designed to accommodate the endoscope during microsurgical procedures.

[0011] In according with these objects, the embodiment of the present invention relies on the clipping/wrapping/attaching of the endoscope to the micro-surgical instrument and to the insertion of the endoscopic image into the oculars of the 3-D operating microscope space using off the shelf readily available technology that is packaged in many operating microscopes. This embodiment would make use of the endoscope more efficient by not crowding the surgical space with new tools but rather transforming each and every instrument used in microscopic neurosurgery into an endoscope carrier.

[0012] Besides, the addition of the bi-dimensional endoscope image into the tri-dimensional microscopic space would easily integrate the endoscope information into a familiar 3-D

space, making the surgery inherently safer and more efficient. The neurosurgeon will see through the microscopic oculars both images: the endoscopic and microscopic ones.

[0013] The embodiment of the invention includes flexible endoscope with diameter no bigger than 3 mm, high definition image capacity, disposable or not, without or with light source, which is attached to the fast 10 cm of micro surgical instrumentals.

[0014] This procedure is done through a clip or a "Velcro type" pad. The clips or pads may be disposable. The clips or pads may be snapped on the carrier micro-surgical instrument and on the endoscope at different points on the respective shafts so as to have multiple potential positions of the endoscope on the carrier micro-surgical instrument. This arrangement allows the endoscope to be used as an instrument and not as a new procedure tool. The surgeon may ask at several junctures of the operation: "load the endoscope on the suction, forceps, etc. and let me see what additional information I can get," and the assistant nurse will attach the endoscope to the micro-surgical instrument in order to attend the surgeon's needs.

[0015] The embodiment includes also the design of special instruments to allow the attachment of the endoscope when necessary.

[0016] In one embodiment the present invention can be a surgical apparatus comprising: a surgical instrument comprising an elongated shaft extending along a longitudinal axis from a proximal end to a distal end, a working element coupled to the distal end of the elongated shaft for manipulating tissue; an endoscope having a tubular body including an image fiber, an endoscopic lens coupled to a distal end of the tubular body and operably coupled to the image fiber, the endoscopic lens defining a viewing field about a central axis; and the endoscope mounted to the elongated shaft of the surgical instrument, the endoscopic lens protruding from an outer longitudinal surface of the elongated shaft, the central axis of the viewing field being oblique to the longitudinal axis of the elongated shaft and intersecting the outer longitudinal surface, the working element located within the viewing field and separated from the central axis by a distance.

[0017] In another embodiment the present invention can be a surgical apparatus comprising: a surgical instrument comprising an elongated shaft extending along a longitudinal axis from a proximal end to a distal end, a working element coupled to the distal end of the elongated shaft for manipulating tissue, the elongated shaft comprising a first indexing feature; an endoscope having a tubular body including an image fiber, an endoscopic lens coupled to a distal end of the tubular body and operably coupled to the image fiber, the endoscopic lens

defining a viewing field about a central axis, the tubular body comprising a second indexing feature; and the endoscope mounted to the elongated shaft of the surgical instrument so that the first and second indexing features mate with one another so as to prevent relative rotation between the elongated shaft and the tubular body, the working element located within the viewing field.

[0018] In yet another embodiment the present invention can be a surgical system comprising: a surgical apparatus comprising: a surgical instrument comprising an elongated shaft and a working element coupled to a distal end of the elongated shaft for manipulating tissue; an endoscope having a tubular body including an image fiber, an endoscopic lens coupled to a distal end of the tubular body and operably coupled to the image fiber, the endoscopic lens defining a viewing field about a central axis; and the endoscope mounted to the elongated shaft of the surgical instrument so that the working element is located within the viewing field; a microscope comprising an ocular lens; and a display displaying an image perceived by the ocular lens and an image perceived by the endoscopic lens.

[0019] In even yet another embodiment the present invention can be a method of performing surgery comprising: mounting an endoscope to a micro-surgical instrument so that a working element of the micro-surgical instrument is located within a viewing field of the endoscope; positioning a microscope so that an ocular lens of the microscope perceives a surgical site; manipulating tissue within the surgical site using the working element of the micro-surgical instrument; and displaying, in a display, an image perceived by the endoscope and an image perceived by the ocular lens.

#### **Brief Description of the Drawings**

[0020] The present invention will become more fully understood from the detailed description and the accompanying drawings, wherein:

[0021] Figure 1 is a schematic drawing of an endoscope/microscope combination assembly according to one embodiment of the present invention;

[0022] Figure 2 is a perspective view of an endoscope incorporated with a surgical instrument according to one embodiment of the present invention;

[0023] Figure 3 is a perspective view of an endoscope incorporated with a surgical instrument using coupling mechanisms according to one embodiment of the present invention;

[0024] Figure 4 is an exploded perspective view showing a distal portion of an endoscope incorporated with a surgical instrument and a coupling mechanism according to one embodiment of the present invention;

[0025] Figure 5 is a perspective view of an endoscope incorporated with a surgical instrument using coupling mechanisms according to one embodiment of the present invention;

[0026] Figure 6 is a closer up view of Figure 5;

[0027] Figures 7-10 are perspective views of the endoscope incorporated with a surgical instrument during operation according to embodiments of the present invention;

[0028] Figures 11-13 are perspective views of the endoscope/microscope combination assembly during operation according to embodiments of the present invention;

[0029] Figure 14 is an inside view of a coupling mechanism according to one embodiment of the present invention;

[0030] Figure 15 is an outside view of a coupling mechanism according to one embodiment of the present invention;

[0031] Figures 16-19 are perspective views of various, non-limiting examples of surgical instruments that may be used in combination with the endoscope/microscope assembly according to embodiments of the present invention.

[0032] Figure 20 is a schematic view of an endoscope mounted to a surgical instrument according to one embodiment of the present invention.

[0033] Figure 21 is an enlarged view of the attached endoscope and surgical instrument of Figure 20.

[0034] Figure 22 is a view of the viewing field V-V from the perspective of the endoscopic lens.

[0035] Figure 23 is a schematic view of the endoscope mounted to the surgical instrument of Figures 20-22.

[0036] Figure 24 is a schematic view of a protuberance according to an alternate embodiment of the present invention.

[0037] Figure 25 is a schematic view of a protuberance according to an alternate embodiment of the present invention.

[0038] Figure 26 is a cross-sectional schematic of a surgical instrument comprising an arch structure integrally formed therewith according to an alternate embodiment of the present invention.

[0039] Figure 27 is a cross-sectional view of the surgical instrument of Figure 26 along the axis X-X.

[0040] Figure 28 is a cross-sectional view of an arch structure according to an alternate embodiment of the present invention.

[0041] Figure 29 is a cross-sectional view of an arch structure according to an alternate embodiment of the present invention.

[0042] Figure 30 is a cross-sectional schematic of a surgical instrument comprising an arch structure integrally formed therewith according to an alternate embodiment of the present invention.

[0043] Figure 31 is a cross-sectional schematic of a surgical instrument comprising a channel integrally formed therein according to an alternate embodiment of the present invention.

[0044] Figure 32 is a cross-sectional schematic of a surgical instrument and an endoscope according to an alternate embodiment of the present invention.

[0045] Figure 33 is a cross-sectional schematic of a surgical instrument and an endoscope according to an alternate embodiment of the present invention.

[0046] Figure 34 is a cross-sectional view of the surgical instrument and endoscope of Figure 33 along the axis Y-Y.

[0047] Figure 35 is a cross-sectional schematic of a surgical tool according to an alternate embodiment of the present invention.

[0048] Figure 36 is a cross-sectional view of the surgical instrument of Figure 35 along the axis M-M.

[0049] Figure 37 is a cross-sectional view of the surgical instrument of Figure 35 along the axis N-N.

[0050] Figure 38 is a cross-sectional schematic of an endoscope according to an alternate embodiment of the present invention.

[0051] Figure 39 is a cross-sectional view of the endoscope of Figure 38 along the axis L-L.

[0052] Figure 40 is a cross-sectional view of the endoscope of Figure 38 along the axis P-P.

[0053] Figure 41 is a cross-sectional view of the endoscope of Figure 38 along the axis O-O.

[0054] Figure 42 is a cross-sectional view of the endoscope of Figure 38 along the axis Q-Q.

### Detailed Description

[0055] The following description of the preferred embodiment(s) is merely exemplary in nature and is in no way intended to limit the invention, its application, or uses.

[0056] The description of illustrative embodiments according to principles of the present invention is intended to be read in connection with the accompanying drawings, which are to be considered part of the entire written description. In the description of the exemplary embodiments of the invention disclosed herein, any reference to direction or orientation is merely intended for convenience of description and is not intended in any way to limit the scope of the present invention. Relative terms such as "lower," "upper," "horizontal," "vertical," "above," "below," "up," "down," "left," "right," "top," "bottom," "front" and "rear" as well as derivatives thereof (e.g., "horizontally," "downwardly," "upwardly," etc.) should be construed to refer to the orientation as then described or as shown in the drawing under discussion. These relative terms are for convenience of description only and do not require that the apparatus be constructed or operated in a particular orientation unless explicitly indicated as such. Terms such as "attached," "affixed," "connected," "coupled," "interconnected," "secured" and similar refer to a relationship wherein structures are secured or attached to one another either directly or indirectly through intervening structures, as well as both movable or rigid attachments or relationships, unless expressly described otherwise. Moreover, the features and benefits of the invention are described by reference to the exemplary embodiments illustrated herein. Accordingly, the invention expressly should not be limited to such exemplary embodiments, even if indicated as being preferred. The discussion herein describes and illustrates some possible non-limiting combinations of features that may exist alone or in other combinations of features. The scope of the invention is defined by the claims appended hereto.

[0057] Referring to Figure 1, an endoscope/operating microscope assembly system **1000** according to one embodiment of the present invention is illustrated. The embodiment illustrated in Figure 1 comprises an operating microscope assembly **100**, an endoscope assembly **200**, a surgical instrument **300**, a surgical site **400**, and at least one coupling mechanism **500**. It should be noted that some of the elements of Figure 1 are generically

shown as blocks. This is done because, in its broadest sense, the invention is not limited to any particular structure, shape and/or arrangement for the endoscope/operating microscope assembly system 1000. Thus, it should be noted that those elements that are generically shown as blocks may take on a variety of other shapes and sizes in other embodiments of the present invention.

[0058] The operating microscope 100 comprises two optical lenses 120 and 122, an ocular viewing area 110, a processor/controller 130, a power source 140 and memory 150. As discussed in more detail below, the processor/controller 130 is configured to receive and process the image data from the endoscopic lens 210 of the endoscope assembly 200 and render an image in an endoscopic display 112 (depicted here in the ocular viewing area 110). The processor/controller 130 is also configured to transmit the image data from the endoscope assembly 200 to memory 150 for storage (temporary or permanent). The power source 140 is configured to provide power to at least the processor/controller 130, memory 150 and endoscopic display 112 (or endoscopic viewing area 112) of the operating microscope 100.

[0059] The optical lenses 120, 122 are configured to provide the user with an enhanced view of the surgical site 400. Collectively, the optical lenses 120, 122 may be referred to as "an ocular lens," whereas each of the optical lenses 120, 122 may be referred to as "an ocular." It should be noted that although the surgical site 400 is generically shown as a circle, the surgical site 400 can be any area of a mammalian organism, living or diseased, on which the user desires to perform surgery.

[0060] The orientation of the optical lenses 120, 122 and the location of focus of each lens may be adjusted by the user. Both optical lenses 120, 122 work in conjunction with the ocular viewing area 110 of the operating microscope 100 to provide the user with an enhanced view of the surgical site 400. In one embodiment, the optical lens 120 is configured to provide the user with an enhanced view of the surgical site 400 through the user's left eye along the first plane 124, while the optical lens 122 is configured to provide the user with an enhanced view of the surgical site 400 through the user's right eye along the second plane 126. Each optical lens 120, 122 provides the user with an enhanced two-dimensional view of the surgical site 400, while the two planes 124, 126 are non-coplanar. Therefore, the combination of the two optical lenses 120, 122 provide the user with an enhanced three-dimensional view of the surgical site 400.

[0061] As discussed in more detail below, the ocular viewing area **110** displays images perceived by the ocular lens **120, 122**, while the endoscopic viewing area **112** displays images perceived by the endoscopic lens **210** of the endoscope **200**. As illustrated in Figure 1, in one embodiment the endoscopic viewing area **112** may be overlaid or displayed within the ocular viewing area **110**, so that the user may view both the ocular viewing area **110** and endoscopic viewing area **112** simultaneously via the ocular lens **120, 122** of the microscope **100**. In such embodiments, the endoscopic display **112** is a digital screen that may be overlaid in the ocular viewing area **110** over or adjacent to the image or view from the microscopic oculars **100**, and provide the user with an additional two-dimensional, non-coplanar view of the surgical site **400**. Further, in one embodiment of the present invention, the ocular viewing area and the endoscopic viewing area may be consecutively displayed on the display in response to a switching signal, the switching signal created by the processor/controller **130** in response to a user input. As discussed in more detail below, the present invention is not limited to the specific type or configuration of ocular viewing area **100** and endoscopic display **112**. Further, the endoscopic display **112** is discussed in more detail below in conjunction with the endoscope assembly **200**.

[0062] It should be noted that the present invention is not so limited, and that in alternate embodiments the ocular viewing area **110** may be just microscopic oculars (without the endoscopic display **112**), be a combination of microscopic oculars and an external display showing an image perceived by the endoscopic lens **210** (e.g. an endoscopic image), or just an external display showing a plurality of images (e.g., images perceived from the ocular lens **120, 122** and images perceived by the endoscopic lens **210** of the endoscope **200**). Further, in alternate embodiments of the present invention, the ocular viewing area **110** may be used to display images perceived by more than two components (e.g., microscopes and endoscopes) simultaneously. For example, a three-dimensional image from the ocular lens **120, 122** of the operating microscope **100** may be displayed simultaneously with more than one other two-dimensional image from more than one endoscope **200** captured from non-coplanar views. Therefore, the present invention is not limited to the use of one endoscope **200** in conjunction with the operating microscope **100**, and thus more than one endoscopic display **112** may be presented to the user simultaneously along with the three-dimensional image provided by the operating microscope **100**.

[0063] It should be noted that the ocular viewing area **110** of the present invention is not limited to the display of images from only an operating microscope **100** and/or endoscope

assemblies **200**, but that in alternate embodiments, the ocular viewing area **110** may display other image data, such as, for example MRI images, in conjunction with images from an operating microscope **100** and/or images from endoscope assemblies **200**.

[0064] Further, it should be noted that in one embodiment of the present invention, the ocular viewing area **110** and the endoscopic viewing area **112** are both displayed on a display. The display may be internal to the microscope **100** and therefore, may be viewed by the user using the ocular lens **120**, **122**. However, in another embodiment, the display may be external to the microscope **100**, such as an external display screen and therefore, may be viewed by the user without the need of the ocular lens **120**, **122**. In embodiments that comprise a display, the ocular viewing area and the endoscopic viewing area may be consecutively displayed on the display in response to a switching signal, the switching signal created by the processor/controller **130** in response to a user input.

[0065] The endoscope assembly **200** comprises an endoscopic lens **210**, a processor/controller **220**, memory **230**, a power supply **240**, and a communication link **250**. As discussed in more detail below, the endoscope assembly **200** may be mounted to a surgical instrument **300** with one or more coupling mechanisms **500** to provide the user with an additional viewing angle of the surgical site **400** during operation. Although shown generically as a rectangle, it should be noted that the surgical instrument **300** may be any instrument used during surgery. Non-limiting examples of surgical instruments are provided in Figures 16-19.

[0066] Figures 2-6 are perspective views of the endoscope incorporated with a surgical instrument according to embodiments of the present invention. It should be noted that Figures 2-6 are non-limiting examples of the user of the endoscope/surgical tool combination in accordance with the present invention.

[0067] Similarly, Figures 7-10 are perspective views of the endoscope incorporated with a surgical instrument during operation according to embodiments of the present invention. It should be noted that Figures 7-10 are non-limiting examples of the user of the endoscope/surgical tool combination in accordance with the present invention.

[0068] As discussed in more detail below, in one embodiment of the present invention, the endoscope **200** comprises a tubular body comprising a proximal end, a distal end, and an image fiber, and an endoscopic lens **210**. The endoscopic lens **210** is coupled to the distal end of the tubular body and operably coupled to the image fiber. In one embodiment of the

present invention, the endoscopic lens **210** is an objective lens. As also discussed in more detail below, the endoscopic lens **210** defines a viewing field **V-V** about a central axis **A-A**.

[0069] In the preferred embodiment, the entire endoscope assembly **200** is flexible. The flexibility of the endoscope **200** enables the endoscope **200** to be easily and securely mounted to a plurality of different surgical instruments **300** having different shapes and sizes. The invention, however, is not so limited and in alternate embodiments parts or all of the endoscope assembly **200** may be rigid.

[0070] The processor/controller **220** is configured to receive and process the image data perceived by the endoscopic lens **210**, and transmit the image data via the communication link **250** to the operating microscope **100** for display in the endoscopic display **112**. The power supply **240** is configured to provide power to the ocular lens **210**, the processor/controller **220**, and the memory **230** of the endoscope **200**. The memory **230** is configured to store the image data (either permanently or temporarily) captured by the ocular lens **210**.

[0071] The endoscopic lens **210** of the endoscope **200** is configured to capture images of a surgical site **400** along the third plane **212**. The third plane **212** is non-coplanar with the first and second planes **124**, **126** of the ocular lenses **120**, **122** of the operating microscope **100**. Therefore, the endoscopic lens **210** provides the user with a third enhanced view of the surgical site **400** from another perspective to enhance operational experience. Specifically, in embodiments where the endoscope **200** is securely mounted to a surgical instrument **300**, the endoscope **200** may provide the user with a third enhanced view of the surgical site from the location and perspective of the surgical instrument **300** being used. Therefore, as the surgical instrument **300** is moved, the third enhanced view taken from the endoscopic lens **210** of the endoscope **200** is constantly changing. Of course, depending on the positioning of the endoscope, the two views may be co-planar with one another.

[0072] As noted above, in one embodiment the ocular viewing area **210** is configured to simultaneously provide the user with an image of the surgical site **400** perceived by the ocular lens **120**, **122** of the operating microscope **100** along with an image of the surgical site **400** perceived by the endoscopic lens **210** of the endoscope **200**. In the preferred embodiment, the two views are non-coplanar and therefore provide the user with multiple views of the surgical site **400** from different perspectives. This enhances the user's ability to work with and manipulate the surgical site **400** they are viewing.

[0073] For example, in microscopic surgery, the present invention provides the user not only with the three-dimensional view of the surgical site 400 through the ocular viewing area 110 of the operating microscope 100, but also simultaneously provides the user with an additional, non-coplanar, two-dimensional view of the operating site 400 taken by the endoscope 200 (also through the ocular viewing area 110, and specifically in the endoscopic display 112). This enables the user to view the surgical site 400 from two different angles through one viewing area (the ocular viewing area 110). Further, if the endoscope is secured to a surgical instrument 300, then the user may perform traditional endoscope surgery with the aid of an additional, non-coplanar, three-dimensional view from the ocular lens 120, 122 of the operating microscope 100. This enhances the view angles the user has during a surgical procedure and provides for the combined benefits of endoscopic surgery and microscopic surgery in one method.

[0074] Figures 11-13 are perspective views of the endoscope/microscope combination assembly during operation according to embodiments of the present invention. The user may simultaneously view images perceived from both the operating microscope 100 and the endoscope 200. As noted above, the images may be viewed by the user by looking through the ocular viewing area 110, or by using an external display. As the user moves the endoscope 200 around the surgical site 400, the user may continuously alter the view in the endoscopic display 112 while keeping the view from the operating microscope 100 stationary. In other embodiments, the user may alter the view taken by the operating microscope 100 while simultaneously altering the endoscopic view. It should be noted that Figures 11-13 are non-limiting examples of the user of the microscope/endoscope assembly combination in accordance with the present invention.

[0075] In one embodiment, the ocular viewing area displays both images in a picture-in-picture format, whereby one image is the primary image that takes up the entire ocular viewing area 110 (or external display) and the second image is the secondary images that is displayed overlapping in a smaller window in one corner of the ocular viewing area 110 (or external display). In such an embodiment, the user may toggle between the two images to change which image is the primary image. In an alternate embodiment, the ocular viewing area 110 (or external display) only displays one view to the user at a time (either the first view from the ocular lens 120, 122 of the operating microscope 100 or the second view from the endoscopic lens 210 of the endoscope 200), and the user may toggle back-and-forth between the two views. Further, in another embodiment, the two images may be displayed in

equal sizes in a side by side manner, so that both images may be viewed equally at once. As discussed above, the switch between the images perceived by the microscope **100** and the endoscope **200** may be activated by an activation signal created by the processor/controller of the microscope **100** in response to a user input.

[0076] It should be noted that in the primary embodiment the image perceived by the ocular lens **120, 122** of the operating microscope **100** is an analog image and the image perceived by the endoscopic lens **210** of the endoscope **200** is a digital image. However, the invention is not so limited and in alternate embodiments either image may be an analog image and/or either image may be a digital image. Further, it is preferable that the image taken by the endoscope and/or the microscope (if digital), be of high definition resolution.

[0077] In one embodiment, the endoscope **200** may further comprise a light source. The light source may be configured at the end of the endoscope **200** comprising the lens **210**. In one embodiment, the light source may be part of or within the lens **210** of the endoscope **200**. The light source would enable the surgical area **400** to be illuminated and thereby enable the lens **210** to capture a clearer image of the surgical area **400**. Further, the endoscope **200** would then bring a light closer to the target, thereby enhancing not only the view through the endoscopic display **112**, but also the view captured by the lenses **220, 222** of the microscope **100**.

[0078] As illustrated at least in Figures 1-6, the endoscope assembly **200** may be coupled to a surgical instrument **300** by means of at least one coupling mechanism **500**. Although the use of two coupling mechanisms **500** is illustrated in Figure 1, it should be noted that the invention is not so limited and in alternate embodiments more or less than two coupling mechanisms **500** may be used to couple the endoscope assembly **200** to a surgical instrument **300**. For example, in the preferred embodiment, two coupling mechanisms **500** are used along the length of the instrument **300** to ensure that the lens **210** of the endoscope **200** sits behind the distal tip of the selected instrument **300**. This helps to insure that the user may use the instrument **300** during operation without the endoscope **200** encumbering the user.

[0079] Referring to Figures 14-15, an embodiment of the coupling mechanism **500** is illustrated. The coupling mechanism **500** comprises an inner surface and outer surface. As illustrated at least in Figures 2-6, the coupling mechanism is configured to wrap around both the endoscope **200** and a surgical instrument **300** to securely attach them together. The coupling mechanism **500** is further configured to be removable from both the endoscope **200**

and surgical instrument **300** to provide the user with the ability to attach the endoscope **200** to other surgical instruments **300**.

[0080] In another embodiment, the coupling mechanism **500** is disposable and comprises sterile Velcro<sup>®</sup> pads that are used to couple the endoscope **200** to and from a surgical instrument **300**. In such embodiments, one corresponding portion of the Velcro<sup>®</sup> pad is securely attached to the surface of the endoscope **200** and the other corresponding portion of the Velcro<sup>®</sup> pad is attached to the surface of the surgical instrument **300**. Therefore, the endoscope **200** may be attached to and removed from the surgical instrument **300** using the Velcro<sup>®</sup> pads. If a plurality of surgical instruments **300** are preconfigured with Velcro<sup>®</sup> pads, then the endoscope **200** may be easily exchanged and attached to the surgical instruments **300** as they are required during the operation.

[0081] In one embodiment, the Velcro<sup>®</sup> pads are attached to the surfaces of the endoscope **200** and the surgical instrument(s) **300** at various different points on the respective surfaces so as to have multiple potential connection positions for the endoscope **200** on the surgical instrument **300**. This enables the endoscope **200** to be positioned at different points of the surgical instrument **300** and allows for greater customization of the endoscope/surgical instrument.

[0082] It should be noted that in alternate embodiments the coupling mechanism **500** may be secured by any other coupling means, so long as the endoscope **200** may be coupled to and removed from the surgical instrument **300**. One benefit residing in that the user may attach the endoscope **200** to one surgical instrument **300** using at least one coupling mechanism **500**, and then later, during the same procedure, attach the endoscope **200** to another surgical instrument **300** using the same or different coupling mechanisms **500**. Therefore, the user may to move the endoscope to and from a plurality of surgical instruments during a single operational procedure, and thus may complete as many stages of the operation as they desire using the endoscope/microscope combination taught herein.

[0083] In one embodiment of the present invention, the width of the coupling mechanism **500** may be between 3 mm and 20 mm, and more preferably between 7 mm and 10 mm. Further, the length of the coupling mechanism **500** may be between 3 cm to 30 cm. However, it should be noted that the invention is not so limited and in alternate embodiments the coupling mechanism **500** may be any length or width deemed necessary to securely attach the endoscope **200** to a surgical instrument **300**.

[0084] In the preferred embodiment, the coupling mechanism(s) 500 used to secure the endoscope to the surgical instrument is disposable. Therefore, the coupling mechanism(s) 500 are preferably thrown away after each use. The invention, however, is not so limited and in alternate embodiments the coupling mechanism(s) 500 may be reused for attachment of the endoscope 200 to more than one surgical instrument 300 during one operational procedure.

[0085] As noted above, one embodiment of the present invention relies on the mounting, clipping, wrapping, and/or attaching of the endoscope 200 to a surgical instrument 300, and to the insertion of the endoscopic image (taken from the lens 210 of the endoscope 200) into the endoscopic display 112 in the ocular viewing area 110 (or external display) of the operating microscope 100. This embodiment makes more efficient use of the endoscope 200 by not crowding the surgical space with new tools but rather transforming each and every surgical instrument 300 used in the surgery into an endoscope carrier. Further, since the images taken by the endoscope 200 are provided in the endoscopic display 112 within the ocular viewing area 110 of the operating microscope 100, the user does not have to take their eyes away from the ocular viewing area and may simultaneously view the surgical site 400 from multiple perspectives.

[0086] The endoscope/instrument combination may be inserted into the surgical area 400 at any time as the operating surgeon feels it is necessary. It should be noted that the use of the endoscope/instrument combination is not limited to operations also involving the use of the operating microscope 100, and may be employed in any body compartment whenever an endoscope may be used. Some non-limiting examples of operations where the present invention may be useful for an operating surgeon include: during operations on aneurysms once the aneurysm is exposed the endoscope/instrument combination may be helpful to look at the aneurysm back wall to clarify the vascular relationships; during microvascular decompression operations the endoscope/instrument combination may reveal absence of vascular compression in areas not yet dissected, avoiding unnecessary dissections; during operation on tumor the endoscope/instrument combination may demonstrate residual tumor in areas not visible by the microscope alone; during spinal operation the endoscope/instrument combination may demonstrate nerve roots compression in areas not yet addressed surgically. It should be noted that the above are non-limiting examples of surgical situations where a surgeon may have use for the endoscope/instrument combination in conjunction with the operating microscope 100 described herein.

[0087] According to one embodiment of the present invention, the surgeon may ask an assistant to load the endoscope 200 on the preferred surgical instrument 300 (such as suction cannula, bipolar forceps, dissecting forceps, etc.) by applying at least one coupling mechanism 500 by at multiple points along the length of the endoscope 200 and surgical instrument 300 making sure that the tip of the endoscope 200 sits behind the tip of the selected instrument 300. For example, in one embodiment it may be preferable to have the endoscope 200 sit at least 5 mm behind the tip of the selected instrument. It should be noted that the invention is not so limited and in alternate embodiments the endoscope 200 may be positioned at or ahead of the tip of the selected instrument 300 so long as the endoscope 200 does not interfere with the user's use of the instrument 300 during the surgical proceeding.

[0088] Further, it should be noted that in alternated embodiments, the endoscope assembly 200 may be integrated with and be one in the same with the surgical instrument 300. Integrating the endoscope 200 with the surgical instrument 300 may be more costly, but may also provide for smaller and more exact instrument/endoscope tools.

[0089] In alternate embodiments of the present invention, the endoscope 200 may be used without being attached to a surgical instrument 300. This may be beneficial when the user just wants to look at a particular section of a surgical site 400 using both the operating microscope 100 and endoscope 200 without being encumbered by a surgical instrument 300.

[0090] In an alternate embodiment, the endoscope 200 may be disposable after each operation. If the endoscope 200 is not disposable, the endoscope 200 should be sterilizable.

[0091] It should be noted that the invention is not limited to the use of just one endoscope 200, and in other alternate embodiments, more than one endoscope 200 may be used. In such embodiments, the ocular viewing area 110 may be configured to display more than two images at one time. For example, the ocular viewing area 110 may be configured to display images from the ocular lens 120, 122 of the operating microscope 100, along with a plurality of images from the plurality of endoscopes 200 or other data sets. For further example, in situations where the operating microscope 100 is not used in conjunction with the endoscope assemblies 200, the ocular viewing area 100 may be configured to display only images from a plurality of endoscopes 200.

[0092] Finally, it should be noted the an endoscope/operating microscope assembly system 1000 may be used during any type of surgery, such as but not limited to, intracranial surgery and spinal surgery.

[0093] Referring to Figure 20, an endoscope **200X** mounted to a surgical instrument **300X** according to one embodiment of the present invention is illustrated. The surgical instrument **300X** and endoscope **200X** of Figure 20 are similar to the surgical instrument **300** and endoscope **200** discussed above with reference to Figures 1-20, therefore, like reference numbers are used to describe like components with the exception that the suffix "X" has been added. For purposes of simplicity, only the differences between the embodiments will be discussed below.

[0094] As exemplified, the endoscope **200X** comprises a tubular body **250X** and an endoscopic lens **210X**. The tubular body **250X** comprises a proximal end **251X**, a distal end **252X**, a tubular sleeve **253X**, and an image fiber (shown in Figure 32). As discussed in more detail below, the tubular sleeve **253X** is the outer most layer of the tubular body **250** and comprises the image fiber within. The endoscopic lens **210X** is coupled to the distal end **252X** of the tubular body **250X** and operably coupled to the image fiber. Although exemplified as a tubular body **250X**, it should be noted that the invention is not so limited, and in alternate embodiments of the present invention, the tubular body **250X** may take on any other shape.

[0095] The surgical instrument **300X** comprises an elongated shaft **301X** extending along a longitudinal axis A-A (shown in Figure 21) from a proximal end **302X** to a distal end **303X**. The elongated shaft **301X** comprises an outer longitudinal surface **304X** that runs the entire length of the elongated shaft **301X**. According to one embodiment of the present invention, the elongated shaft **301X** is substantially rigid. However, the invention is not so limited, and in alternate embodiments, the elongated shaft **301X** may be partially or completely flexible.

[0096] A working element **350X** is coupled to the distal end **303X** of the elongated shaft **301X**. The working element **350X** is a tool portion of the surgical instrument that engages, cuts, dissects, or otherwise manipulates tissue during surgical procedures. Examples of surgical instruments **300X** include, but are not limited to, suction, dissectors, forceps, clamps, scissors, needle holders, bipolar coagulators, etc. Further, according to one embodiment of the present invention, the surgical instrument **300X** is a micro-surgical instrument.

[0097] Figure 21 illustrates an enlarged view of the attached endoscope **200X**/surgical instrument **300X** of Figure 20. Referring to Figures 20 and 21 concurrently, the endoscope **200X** is mounted to the outer longitudinal surface **304X** of the elongate shaft **301X** of the

surgical instrument **300X** so that the endoscopic lens **210X** of the endoscope **200X** protrudes (or diverges) from the outer longitudinal surface **304X** of the elongated shaft **301X**. As discussed in more detail below, the protrusion or divergence of the endoscopic lens **210X** relative to the outer longitudinal surface **304X** of the elongated shaft **301X** ensures that the working element **350X** only obstructs a portion, and not a majority, of the viewing field of the endoscopic lens. Therefore, when the user is performing surgery using the attached endoscope **200X**/surgical instrument **300X**, the images perceived by the endoscope provide a view of working element **350X**, while remaining substantially unobstructed by the working element **350X**. Thus, the user is provided with an enlarged perspective of the surgical site via the endoscopic lens **210X**.

[0098] As shown, the tubular body **250X** of the endoscope **200X** comprises a base portion **260X** and a protruding portion **270X**. The base portion **260X** is substantially orthogonal with and extends parallel to the longitudinal axis **A-A** of the elongated shaft **301X**, while the protruding portion **270X** is oblique to the longitudinal axis **A-A** of the elongated shaft **301X**. Further, the protruding portion **270X** comprises the distal end **252X** of the tubular body **250X**. The protruding portion **270X** is oblique to the base portion **260X**, which enables the endoscopic lens **210X** to protrude or diverge from the outer longitudinal surface **304X** of the elongated shaft **301X**.

[0099] The endoscopic lens **210X** of the endoscope **200X** defines a viewing field **V-V** about a central axis **C-C**. In the exemplified embodiment of the present invention, the viewing field **V-V** is substantially conical in shape. However, the invention is not so limited, and in alternate embodiments of the present invention the viewing field **V-V** may take on other shapes.

[00100] Due to the protruding portion **270X** being oblique to the longitudinal axis **A-A** of the elongated shaft **301X**, the central axis **C-C** of the viewing field **V-V** of the endoscopic lens **210X** is also oblique to the longitudinal axis **A-A** of the elongated shaft **301X**. Therefore, the central axis **C-C** of the viewing field **V-V** is oriented at an oblique angle  $\theta$  to the longitudinal axis **A-A** of the elongated shaft **301X**. Preferably, the oblique angle  $\theta$  is between  $3^\circ$  to  $75^\circ$ . More preferably, the oblique angle  $\theta$  is between  $5^\circ$  to  $45^\circ$ . Most preferably, the oblique angle  $\theta$  is between  $15^\circ$  to  $30^\circ$ . Nonetheless, it should be noted that the invention is not limited to the central axis **C-C** being positioned at any specific oblique angle  $\theta$  in all embodiments.

[0100] Also due to the protruding portion 270X being oblique to the longitudinal axis A-A of the elongated shaft 301X, the central axis C-C of the viewing field V-V of the endoscopic lens 210X is also oblique to the working axis W-W of the working element 350X. Therefore, the central axis C-C of the viewing field V-V is oriented at an oblique angle  $\beta$  to the working axis W-W of the working element 350X. Preferably, the oblique angle  $\beta$  is between 2° to 65°. More preferably, the oblique angle  $\beta$  is between 5° to 40°. Most preferably, the oblique angle  $\beta$  is between 13° to 25°. Nonetheless, it should be noted that the invention is not limited to the central axis C-C being positioned at any specific oblique angle  $\beta$  in all embodiments.

[0101] The central axis C-C of the viewing field V-V also intersects the outer longitudinal surface 304X of the elongated shaft 301X. Further, since the central axis C-C intersects the outer longitudinal surface 304X of the elongated shaft 301X, the central axis C-C of the viewing field V-V is substantially coplanar with the longitudinal axis A-A of the elongated shaft 301X. Finally, since the central axis C-C of the viewing field V-V of the endoscopic lens 210X is also oblique to the longitudinal axis A-A of the elongated shaft 301X, the working element 350X of the surgical instrument 300X is located within the viewing field V-V of the endoscopic lens 210X but separated from the central axis C-C of the endoscopic lens 210X by a distance  $D_3$  (shown in Figure 22).

[0102] As noted above and discussed in more detail below, the coupling mechanism 500X of the exemplified embodiment secures the endoscope 200X to the elongated shaft 301X so that the endoscopic lens 210X is substantially stationary relative to the elongated shaft 301X. In the exemplified embodiment, the coupling mechanism 500X comprises a protuberance 510X and a retaining member 520X. As discussed in more detail below, the combination of the protuberance 510X and the retaining member 520X is one way to create the oblique angle  $\theta$  between the central axis C-C of the viewing field V-V and the longitudinal axis A-A of the elongated shaft 301X.

[0103] The protuberance 510X is located at a first longitudinal distance  $D_1$  from the distal end 303X of the elongated shaft 300X. Further, the protuberance 510X extends from the outer longitudinal surface 304X of the elongated shaft 301X in a first transverse direction. In the exemplified embodiment, the first transverse direction is radially upward from the outer longitudinal surface 304X. However, the invention is not so limited and in other embodiments, the first transverse direction may be any direction that is radially outward from the outer longitudinal surface 304X.

[0104] The retaining member **520X** secures the endoscope **200X** to the elongated shaft **301X**. In one embodiment of the present invention, the retaining member **520X** may be similar to the coupling mechanism **500** as discussed above with reference to Figures 14-16. The retaining member **520X** is located at a second longitudinal distance  $D_2$  from the distal end **303X** of the elongated shaft **301X**. As shown in Figure 21 and discussed in more detail below with reference to Figure 23, the second longitudinal distance  $D_2$  is greater than the first longitudinal distance  $D_1$ . Preferably, the retaining member **520X** is made of a medical grade resilient material so as to create a compression fit around the tubular body **250X** and the elongated shaft **301**. However, the invention is not so limited, and in an alternate embodiment of the present invention, the retaining member **520X** is made of a rigid medical grade plastic or metal.

[0105] Referring to Figure 22, a view of the viewing field **V-V** from the perspective of the endoscopic lens **210X** is illustrated. Since the viewing field **V-V** of the exemplified embodiment is substantially conical in shape, the view of Figure 22 is circular in shape. However, as discussed above, the invention is not so limited and in alternate embodiments the viewing field **V-V** is not conical in shape, and therefore the view may not be circular in shape.

[0106] In the exemplified embodiment, the viewing field **V-V** comprises a central axis **C-C**, a radius  $r$ , an upper hemisphere **II**, and a lower hemisphere **III**. The angles  $\theta$ ,  $\beta$  are selected such that the working element **350X** of the surgical tool **300X** is positioned in the lower hemisphere **III** of the viewing field **V-V**. Further, it should be noted that the working element **350X** obstructs only a minority of the lower hemisphere **III**. In the exemplified embodiment, the upper hemisphere **II** is the portion of the viewing field **V-V** that is above the central axis **C-C** and the lower hemisphere **III** is the portion of the viewing field **V-V** that is below the central axis **C-C**.

[0107] Since the central axis **C-C** of the viewing field **V-V** of the endoscopic lens **210X** diverges from the working element **350X** (and the longitudinal axis **A-A**), the working element **350X** is at a distance  $D_3$  from the central axis **C-C**. Further, the distance  $D_3$  is preferably at least  $1/3 r$ . Therefore, the inner one third ( $1/3$ ) of the radius  $r$  of the viewing field **V-V** is free of the working element **350X**, providing an unobstructed view of the surgical site for the user. However, in alternate embodiments of the present invention, the working element **350X** may be located in both hemispheres **II**, **III**, may be located within the

inner one third ( $1/3$ ) of the radius  $r$ , and/or may obstruct a majority of the lower hemisphere III.

[0108] Referring to Figure 23, a schematic of the endoscope **200X** mounted to the surgical instrument **300X** of Figures 20-22 is illustrated. As exemplified in Figure 23, the coupling mechanism **500X** comprises a protuberance **510X** and a retaining member **520X**. As discussed above with reference to Figure 21, the protuberance **510X** is located at a first longitudinal distance  $D_1$  from the distal end **303X** of the elongated shaft **301X**, and extends from the outer longitudinal surface **304X** of the elongated shaft **301X** in a first transverse direction, the first transverse direction being radially upward from the outer longitudinal surface **304X**. Further, the retaining member **520X** secures the endoscope **200X** to the elongated shaft **301X** and is located at a second longitudinal distance  $D_2$  from the distal end **303X** of the elongated shaft **301X**. Finally, as noted above, the second longitudinal distance  $D_2$  is greater than the first longitudinal distance  $D_1$ .

[0109] In the exemplified embodiment of Figure 23, the endoscopic lens **210X** (specifically, the central axis **C-C** of the viewing plan **V-V** of the endoscopic lens **210X**) is diverged from the longitudinal axis **A-A** of the elongated shaft **301X** and from the working element **350X** through the use of a combination of the protuberance **510X** and the retaining member **520X**. Specifically, when a portion of the base portion **260X** of the tubular body **250X** resides on the outer longitudinal surface **304X** of the elongated shaft **301X** and under the retaining member **520X**, and a portion of the tubular body **250X** resides on the protuberance **510X**, two substantially opposing forces are exerted on the tubular body **250X**. The protuberance **510X** exerts a first force  $F_1$ , while the retaining member **520X** exerts a second force  $F_2$ , such that the first force  $F_1$  and the second force  $F_2$  are in substantially opposite directions. The exertion of the two forces  $F_1$ ,  $F_2$  results in the endoscopic lens **210X** being diverged away from the longitudinal axis **A-A** of the elongated shaft **301X** and from the working element **350**. Stated another way, in such embodiments the protuberance **510X** acts as a fulcrum on the tubular body **250X** of the endoscope **200X** that forces the protruding portion **270X** (and endoscopic lens **210X**) of the endoscope **200X** to diverge from the outer longitudinal surface of the elongated shaft **301X**.

[0110] Nonetheless, as discussed in more detail below, the divergence of the endoscopic lens **210X** from the outer longitudinal surface of the elongated shaft **301X** may be created using other embodiments of the coupling mechanism **500X**.

[0111] Referring to Figures 24-25, two examples of protuberances **510A**, **510B** according to two embodiments of the present invention are illustrated. The surgical instruments **300A**, **300B** of Figures 24-25 are similar to the surgical instrument **300X** discussed above with reference to Figures 20-23, therefore, like reference numbers are used to describe like components with the exception that the suffix "A"/"B" has been used in place of the suffix "X." For purposes of simplicity, only the differences between the embodiments will be discussed below.

[0112] The protuberance **510A** of Figure 24 has a contoured surface **511A**, so that the protuberance **510A** may act as a ramp for the endoscope **200**. As exemplified, the surface **511A** is more specifically a concave surface. Further, in one embodiment, the protuberance **510A** has a gradually increasing slope from the outer longitudinal surface **304A** of the elongated shaft **301A** to the peak **512A** of the protuberance **510A**. Although the peak **512A** of the protuberance **510A** is rounded, the invention is not so limited, and in other embodiments the peak **512A** may be pointed.

[0113] The protuberance **510B** of Figure 25 has a linear surface **511B**, so that the protuberance **510B** may act as a ramp for the endoscope **200**. As exemplified, the protuberance **510B** has a constant slope from the outer longitudinal surface **304B** of the elongated shaft **301B** to the peak **512B** of the protuberance **510**. Although the peak **512B** of the protuberance **510B** is pointed, the invention is not so limited, and in other embodiments the peak **512B** may be rounded.

[0114] Referring to Figures 26 and 27 concurrently, another alternative embodiment of the present invention will be discussed. Referring to Figure 26, a cross-sectional schematic of a surgical instrument **300D** comprising an arch structure **540D** integrally formed therewith according to an embodiment of the present invention is illustrated. Referring to Figure 27, a cross-sectional view of the surgical instrument **300D** of Figure 26 along the axis **X-X** is illustrated. The surgical instrument **300D** of Figures 26-27 is similar to the surgical instrument **300X** and endoscope **200X** discussed above with reference to Figures 20-23, therefore, like reference numbers are used to describe like components with the exception that the suffix "D" has been added. For purposes of simplicity, only the differences between the embodiments will be discussed below.

[0115] The arch structure **540D** is an open-ended arch structure that protrudes from and is integrally formed with the outer longitudinal surface **304D** of the elongated shaft **301D** of the

surgical instrument **300D**. The arch structure **540D** defines a passageway **550D** for retaining a portion of the endoscope **200D**, and comprises a side wall **541D** and a floor **542D**. Further, the passageway **550D** formed by the arch structure **540D** comprises an entrance **551D** and an exit **552D**, both configured to receive the tubular body **250D** of the endoscope **200D**.

[0116] As discussed in more detail below, the transverse cross-section of the arch structure **540D** is shaped and sized to accommodate the tubular body **250D** of the endoscope **200D** within the passageway **550D**. According to one embodiment, the transverse cross-section is shaped and sized to create a tight fit between the inner surface of the side wall **541D** and the tubular body **250D**. However, the invention is not so limited, and in alternate embodiments of the present invention, the transverse cross section is sized and shaped to create a loose fit or a gap between the inner surface of the side wall **541D** and the tubular body **250D**.

[0117] Although not exemplified in Figures 26 and 27, the tubular body **250D** of the endoscope **200D** may be inserted into the arch structure **540D** via the entrance **551D** of the passageway **550D**. Upon insertion, the tubular body **250D** will rest on the floor **542D** of the arch structure **540D** and within the passageway **550D**. As discussed above, depending on the particular embodiment of the arch structure **540D**, the tubular body **250D** may, but does not necessarily, engage the inner surface of the side wall **541D**. After the tubular body **250D** is within the passageway **550D**, the tubular body **250D** may extend along the elongated shaft **301D** until it engages the protrusion **510D**, which is located adjacent and just beyond the exit **552D** of the passageway closest to the working element **350D**. Once inside the passageway **550D**, the side wall **541D** of the arch structure **540D** prevents relative rotational movement of the endoscope **200D** around the surgical instrument **300D**. More specifically, the side wall **541D** prevents the endoscope **200D** from becoming separated from the surgical instrument **300D**. In this manner, the arch structure **540D** acts as a retaining structure and retains the endoscope **200D** on the surgical instrument **300D**.

[0118] Upon engaging and extending over the protrusion **510D**, the tubular body **250D** of the endoscope **200D** diverges away from the outer longitudinal surface **304D** of the elongated shaft **301D**. The arch structure **540D** and protuberance **510D** act in a manner similar to the retaining member **520X** and protuberance **510X** of Figure 23. As such, the protuberance **510D** exerts a first force  $F_1$ , while the arch structure **540D** exerts a second force  $F_2$ , such that the first force  $F_1$  and the second force  $F_2$  are in substantially opposite directions. The exertion of the two forces  $F_1$ ,  $F_2$  results in the endoscopic lens **210D** of the endoscope **200D** being diverged away from the longitudinal axis **A-A** of the elongated shaft **301D** and from

the working element **350D**. Therefore, the endoscope **200D** may be positioned along the outer longitudinal surface **304D** of the elongated shaft **301D** in a position similar to that shown in Figures 20 and 21, whereby the central axis **C-C** of the viewing field **V-V** of the endoscope **200D** is oblique to the longitudinal axis **A-A** of the elongated shaft **301D**, and the working element **350D** is located within the viewing field.

[0119] However, the invention is not so limited, and in an alternate embodiment of the present invention, the arch structure **540D** does not exert a second force  $F_2$  on the tubular body **250D** of the endoscope **200D**. In such embodiments, the tubular body **250D** is still diverged away from the outer longitudinal surface **304D** of the elongated shaft **301D**, but the tubular body **250D** does not come into contact with the inner surface of the side wall **541D**.

[0120] In one embodiment of the present invention, the arch structure **540D** is comprised of the same material as that of the elongated shaft **301D** of the surgical instrument **300D**. However, the invention is not so limited, and in alternate embodiments the arch structure **540D** may be comprised of any suitable medical grade material, such as, but not limited to medical grade plastics and medical grade metals.

[0121] Referring to Figures 28 and 29, cross-sectional views of arch structures **540E** according to two alternate embodiments of the present invention are illustrated. The surgical instrument **300E** of Figures 28 and 29 are similar to the surgical instrument **300D** discussed above with reference to Figures 26-27, therefore, like reference numbers are used to describe like components with the exception that the suffix "E" has been added. For purposes of simplicity, only the differences between the embodiments will be discussed below.

[0122] The arch structure **540E** of Figure 28 is an open-ended arch structure that protrudes from and is integrally formed with the outer longitudinal surface **304E** of the elongated shaft **301E** of the surgical instrument **300E**. The arch structure **540E** defines a passageway **550E** for retaining a portion of the endoscope **200E**. The arch structure **540E** comprises two side walls **541E**, an open top end **543E**, and a floor **544E**. Further, each of the side walls **541E** comprises a retaining nub **542E**. Finally, similar to above and depending on the particular embodiment of the present invention, the transverse cross-section of the arch structure **540E** may be such that a tight fit or a loose fit is created between the inner surface of the two side walls **541E** and the tubular body **250E** of an endoscope **200E**.

[0123] The tubular body **250E** of the endoscope **200E** may be inserted into the arch structure **540E** via the open top end **543E**. Upon insertion, the tubular body **250E** will rest on the floor

544E of the arch structure 540E and within the passageway 550E. As discussed above, depending on the particular embodiment of the arch structure 540E, the tubular body 250E may, but does not necessarily, engage the inner surface of the two side walls 541E. After the tubular body 250E is within the passageway 550E, the tubular body 250E may extend along the elongated shaft 301E until it engages the protrusion 510E, which is located adjacent to and just beyond an exit of the passageway 550E closest to the working element 350E. Upon engaging and extending over the protrusion 510E, the tubular body 250E of the endoscope 200E diverges away from the outer longitudinal surface 304E of the elongated shaft 301E.

[0124] Further, it should be noted that when the endoscope 200E is positioned within the passageway 550E, the side walls 541E of the arch structure 540E prevent relative rotational movement of the endoscope 200E around the surgical instrument 300E. Similarly, the retaining nubs 542E prevent the endoscope 200E from unintentionally exiting the arch structure 540E via the open top end 543E.

[0125] The arch structure 540F of Figure 29 is a c-clamp arch structure 540F that protrudes from and is integrally formed with the outer longitudinal surface 304F of the elongated shaft 301F of the surgical instrument 300F. Similarly, the arch structure 540F defines a passageway 550F for retaining a portion of the endoscope 200F. The arch structure 540F comprises a hook-shaped wall 541F, an opening 542F, a retaining nub 543F, and a floor 544F. Finally, similar to above and depending on the particular embodiment of the present invention, the transverse cross-section of the arch structure 540F may be such that a tight fit or a loose fit is created between the inner surface of the hook-shaped wall 541F and the tubular body 250F of an endoscope 200F.

[0126] The tubular body 250F of the endoscope 200F may be inserted into the arch structure 540F via the opening 542F. Upon insertion, the tubular body 250F will rest on the floor 544F of the arch structure 540F and within the passageway 550F. As discussed above, depending on the particular embodiment of the arch structure 540F, the tubular body 250F may, but does not necessarily, engage the inner surface of the hook-shaped wall 541F. After the tubular body 250F is within the passageway 550F, the tubular body 250F may extend along the elongated shaft 301F until it engages the protrusion 510F, which is located adjacent to an exit of the passageway closest to the working element 350F. Upon engaging and extending over the protrusion 510F, the tubular body 250F of the endoscope 200F diverges away from the outer longitudinal surface 304F of the elongated shaft 301F.

[0127] Further, it should be noted that when the endoscope 200F is within the passageway 550, the hook-shaped wall 541F of the arch structure 540F prevents relative vertical movement and relative rotational movement of the endoscope 200F in directions opposing the opening 542F. The retaining nub 543F of the arch structure 540F prevents the endoscope 200F from unintentionally exiting the passageway 550F via the opening 542F.

[0128] Referring to Figure 30, a cross-sectional schematic of a surgical instrument 300C comprising an arch structure 540C integrally formed therewith according to an alternate embodiment of the present invention is illustrated. The surgical instrument 300C of Figure 30 is similar to the surgical instrument 300D and endoscope 200D discussed above with reference to Figures 26-27, therefore, like reference numbers are used to describe like components with the exception that the suffix "C" has been added. For purposes of simplicity, only the differences between the two embodiments will be discussed below.

[0129] Unlike the embodiment of Figures 26-27, the embodiment of Figure 30 comprises a protuberance 510C that resides at least partially within the passageway 550C created by the arch structure 540C. Therefore, as opposed to the embodiment described above with reference to Figures 26-27, the protuberance 510C is not located adjacent an exit of the passageway 550C, but at least partially within the passageway 550C. It should be noted that in one embodiment of the present invention, the protuberance 510C resides entirely within the passageway 550C, while in another embodiment of the present invention, the protuberance 510C resides only partially within the passageway 550C.

[0130] As exemplified, the arch structure 540C is sloped in the longitudinal direction in a manner similar to that of the slope of the protuberance 510C. This allows for the tubular body 250C of the endoscope 200C to be inserted into the arch structure 540C via the entrance 551C of the passageway 550C, extend along the elongated shaft 301C until it engages the protrusion 510C, and diverge away from the outer longitudinal surface 304C of the elongated shaft 301C. By sloping the arch structure 540C in a manner similar to the slope of the protuberance 510C, the inner surface of the arch structure 540C may form a tight fit around the tubular body 250C of the endoscope 200C to more securely hold the endoscope 200C in place. Nonetheless, it should be noted that the invention is not so limited, and in alternate embodiments of the present invention, the slope of the arch structure 540C may be omitted or may be greater or less than the slope of the protuberance 510C.

[0131] Referring to Figure 31, a cross-sectional schematic of a surgical instrument **300G** comprising a channel **600G** integrally formed therein according to one embodiment of the present invention is illustrated. The surgical instrument **300G** of Figure 31 is similar to the surgical instrument **300X** discussed above with reference to Figures 20-23, therefore, like reference numbers are used to describe like components with the exception that the suffix "G" has been added. For purposes of simplicity, only the differences between the embodiments will be discussed below.

[0132] As exemplified, the surgical instrument **300G** comprises a channel **600G** that defines a passageway for retaining a portion of the endoscope **200G**. The channel **600G** extends longitudinally along the axis **A-A** of the elongated shaft **301G** prior to sloping obliquely to the axis **A-A** at a distance **D<sub>4</sub>** from the distal end **303G** of the elongated shaft **301G**. After the channel **600G** slopes obliquely to the axis **A-A**, the channel **600G** exits the outer longitudinal surface **304G** at an exit point **601G**, the exit point **601G** being at a distance **D<sub>5</sub>** from the distal end **303G** of the elongated shaft **301G**. It should be noted that the present invention is not limited to any specific distance **D<sub>4</sub>**, distance **D<sub>5</sub>**, or slope of the channel **600G**.

[0133] As exemplified, the passageway of the channel **600G** is configured to retain the tubular body **250G** of an endoscope **200G**. The interior of the channel **600G** prevents relative rotational movement and relative transverse movement of the tubular body **250G** about the elongated shaft **301G**. Preferably, the interior of the channel **600G** forms a tight fit around the tubular body **250G**. However, the invention is not so limited, and in alternate embodiments, the interior of the channel **600G** may form a loose fit around the tubular body **250G**.

[0134] Referring to Figure 32, a cross-sectional schematic of a surgical instrument **300H** and an endoscope **200H** according to one embodiment of the present invention is illustrated. The surgical instrument **300H** and endoscope **200H** of Figure 32 is similar to the surgical instrument **300X** and endoscope **200X** discussed above with reference to Figures 20-23, therefore, like reference numbers are used to describe like components with the exception that the suffix "H" has been added. For purposes of simplicity, only the differences between the embodiments will be discussed below.

[0135] As shown, the endoscope **200H** of Figure 32 comprises a tubular body **250H** and an endoscopic lens **210H**. The tubular body **250H** comprises a tubular sleeve **253H** and an

image fiber **255H**. Generally, the tubular sleeve **253H** is a casing that encapsulates the image fiber **255H**. Preferably, the tubular sleeve **253H** is made of a flexible, medical grade, resilient material so to create a compression fit around the image fiber **255H** of the endoscope **200H**. However, the invention is not so limited, and in alternate embodiments of the present invention, the tubular sleeve **253H** may be made of a rigid medical grade plastic or metal.

[0136] The tubular sleeve **253H** of Figure 32 comprises a block **254H**. As described below, the block **254H** may be conceptualized as a ramp or protuberance. Preferably, the block **254H** is integrally formed with the tubular sleeve **253H**. However, the invention is not so limited, and in alternate embodiments of the present invention the block **254H** may be integrally formed with the outer longitudinal surface **304H** of the elongated shaft **301H**, or may be a separate component that may be secured to one or more of the tubular sleeve **253H** and the outer longitudinal surface **304H** of the elongated shaft **301H**.

[0137] As exemplified, during operation a retaining member **520H** secures the endoscope **200H** to the elongated shaft **301H**. In such instances, the block **254H** is configured between the endoscopic lens **210H** and the outer longitudinal surface **304H**, so that the block **254H** diverges the endoscopic lens **210H** away from the outer longitudinal surface **304H** of the elongated shaft **301H** and from the working element **350H**. As such, the central axis **C-C** of the viewing field **V-V** of the endoscope **200H** is oblique to the longitudinal axis **A-A** of the elongated shaft **301H**.

[0138] Although exemplified as part of the tubular sleeve **253H**, in alternate embodiments of the present invention, the block **254H** may be formed integrally with the elongated shaft **301H** of the surgical tool **300H**, or may be a separate component that is secured to one or more of the elongated shaft **301H** and the tubular sleeve **253H**.

[0139] Referring to Figure 33, a cross-sectional schematic of a surgical instrument **300I** and an endoscope **200I** according to an alternate embodiment of the present invention is illustrated. Referring to Figure 34, a cross-section of the surgical instrument **300I** and endoscope **200I** of Figure 33 along the axis **Y-Y** is illustrated. The surgical instrument **300I** of Figure 33 is similar to the surgical instrument **300X** and endoscope **200X** discussed above with reference to Figure 32, therefore, like reference numbers are used to describe like components with the exception that the suffix "I" has been added. For purposes of simplicity, only the differences between the embodiments will be discussed below.

[0140] As shown in Figures 33-34, the surgical instrument **300I** further comprises a blockade

**310I** and a first indexing feature **320I**, while the endoscope **200I** further comprises a second indexing feature **321I**. The first indexing feature **320I** extends longitudinally along the outer longitudinal surface **304I** of the elongated rod **301I**. Similarly, the second indexing feature **321I** extends longitudinally along the tubular sleeve **353I** of the endoscope **200I**. In the exemplified embodiments, the first indexing feature **320I** is made of the same material and integrally formed in the outer longitudinal surface **304** of the elongated rod **301**. Similarly, the second indexing feature **321I** is integrally formed in the tubular sleeve **353** of the endoscope **200**. Finally, as discussed in more detail below, the blockade **310I** comprises a transverse wall **311I**.

[0141] In the exemplified embodiment, the first indexing feature **320I** is a longitudinal rib and the second indexing feature **321I** is a longitudinal groove. More specifically, the first indexing feature **320I** is a dovetail shaped rib, while the second indexing feature **321I** is a dovetail shaped groove. However, it should be noted that the invention is not so limited, and in alternate embodiments, the first and second indexing features **320I**, **321I** may be any shape, such as but not limited to, T-shaped, V-shaped, or L-shaped rib. Nonetheless, it should be noted that the first and second indexing features **320I**, **321I** should be corresponding shapes so that they may mate with one another. Further, in alternate embodiments of the present invention, the first indexing feature **320I** may be a longitudinal groove, while the second indexing feature **321I** is a longitudinal rib. Therefore, the invention is not limited to whether the first or second indexing features **320I**, **321I** are a longitudinal groove and longitudinal rib respectively.

[0142] As shown in Figure 34, the first indexing feature **320I** and the second indexing feature mate with one another so that the first indexing feature **320I** may be inserted into and slid longitudinally along the second indexing feature **321I**. Once the first indexing feature **320I** is mated with the second indexing feature **321I**, the endoscope **200I** is mounted to the outer longitudinal surface **304I** of the elongated shaft **301I**. The second indexing feature **321I** of the tubular body **250I** (specifically, the tubular sleeve **253I**) may then be slid along the first indexing feature **320I** until the second indexing feature **321I** contacts the transverse wall **311I** of the blockade **310I**. As such, the blockade **310I** acts as a barrier to prevent additional longitudinal movement of the second indexing feature **321I** along the outer longitudinal surface **304I** of the elongated shaft **301I**. When mated, the first and second indexing features **320I**, **321I** prevent rotation of the tubular body **250I** relative to the elongated shaft **301I**. Further, it should be noted that the working element **350I** is located within the viewing field

V-V of the endoscopic lens **210I** when the first and second indexing features **320I**, **321I** are mated with one another and the second indexing feature **321I** is in contact with the transverse wall **311I** of the blockade **310I**. Such a configuration provides the user with a more consistent and stable view of the working element **350I** via the endoscopic lens **210I**.

[0143] Finally, although a retaining member **520I** is illustrated, the invention is not so limited, and in alternate embodiments the retaining member **520I** may be omitted. Further, although the tubular sleeve **253I** comprises block **254I**, the invention is not so limited, and in alternate embodiments, the block **254I** may be omitted. In such embodiments, the endoscopic lens **210I** is not diverged away from the outer longitudinal surface **304** of the elongated shaft **301**.

[0144] Figures 35-42 will now be discussed concurrently. Referring to Figures 35 a schematic of a surgical instrument **300J** according to an alternate embodiment of the present invention is illustrated. Referring to Figure 36, a cross-section of the surgical instrument **300J** of Figure 35 along the axis M-M is illustrated. Referring to Figure 37, a cross-section of the surgical instrument **300J** of Figure 35 along the axis N-N is illustrated. The surgical instrument **300J** of Figures 35-37 is similar to the surgical instrument **300X** discussed above with reference to Figures 20-23, therefore, like reference numbers are used to describe like components with the exception that the suffix "J" has been added. For purposes of simplicity, only the differences between the embodiments will be discussed below.

[0145] The surgical instrument **300J** comprises both a lateral indexing rib **330J** and a longitudinal indexing rib **331J** raised off and protruding from the outer longitudinal surface **304**. As discussed in more detail below, the lateral and longitudinal indexing ribs **330J**, **331J** are configured to mate with corresponding slots **280J**, **281J** on the endoscope **200J**, such that the transverse and longitudinal movement of the endoscope **200J** with respect to the surgical instrument **300J** is restricted.

[0146] As shown in Figure 36, the lateral indexing rib **330J** comprises an upper surface **334J** and two flanges **332J**. The upper surface **334J** is substantially parallel with the outer longitudinal surface **304** of the elongated shaft **301**, while the flanges **332J** are oblique to both the upper surface **334J** and the outer longitudinal surface **304**. Further, as shown in Figure 37, the longitudinal indexing rib **331J** comprises an upper surface **335J** and two flanges **333J**. The upper surface **335J** is substantially parallel with the outer longitudinal surface **304** of the elongated shaft **301**, while the flanges **333J** are oblique to both the upper

surface **335J** and the outer longitudinal surface **304**. The longitudinal indexing rib **331J** is substantially similar to the lateral indexing rib **330J**, with the exception that the indexing ribs **330J**, **331J** are offset by  $90^\circ$  with respect to one another.

[0147] More specifically, in the exemplified embodiment the lateral indexing rib **330J** and the longitudinal indexing rib **331J** are dovetail shaped ribs. However, it should be noted that the invention is not so limited, and in alternate embodiments, the lateral indexing rib **330J** and the longitudinal indexing rib **331J** may be any shape, such as but not limited to, T-shaped, V-shaped, or L-shaped ribs.

[0148] Referring to Figures 38 a schematic of an endoscope **200J** according to an alternate embodiment of the present invention is illustrated. Referring to Figure 39, a cross-section of the endoscope **200J** of Figure 38 along the axis **L-L** is illustrated. Referring to Figure 40, a cross-section of the endoscope **200J** of Figure 38 along the axis **P-P** is illustrated. Referring to Figure 41, a cross-section of the endoscope **200J** of Figure 38 along the axis **O-O** is illustrated. Referring to Figure 42, a cross-section of the endoscope **200J** of Figure 38 along the axis **Q-Q** is illustrated. The endoscope **300J** of Figures 38-42 is similar to the endoscope **200X** discussed above with reference to Figures 20-23, therefore, like reference numbers are used to describe like components with the exception that the suffix "J" has been added. For purposes of simplicity, only the differences between the embodiments will be discussed below.

[0149] The endoscope **200J** comprises a lateral slot **280J** and a longitudinal slot **281J**. The lateral slot **280J** comprises an entry section **282J** and a retaining section **283J**. Similarly, the longitudinal slot **281J** comprises an entry section **284J** and a retaining section **285J**. As discussed in more detail below, the entry sections **282J**, **284J** are configured to allow for the insertion of the indexing ribs **330J**, **331J** into the lateral and longitudinal slots **280J**, **281J** respectively, while the retaining sections **283J**, **285J** are configured for the locking and restricting of the lateral and longitudinal slots **280J**, **281J** in place. The lateral slot **280J** is substantially similar to the longitudinal slot **281J**, with the exception that the slots **280J**, **281J** are offset by  $90^\circ$  with respect to one another.

[0150] As shown in Figures 39 and 41, the entry section **282J** has a cross-sectional shape of a rectangle, while the retaining section **283J** has a cross-sectional shape of a dovetail. As discussed in more detail below, the retaining section **283J** comprises shoulders **286J** that coincide with the flanges **332J** of the lateral indexing rib **330J**. Similarly, and as shown in

Figures 40 and 42, the entry section **284J** has a cross-sectional shape of a rectangle, while the retaining section **285J** has a cross-sectional shape of a dovetail. As also discussed in more detail below, the retaining section **285J** comprises shoulders **287J** that coincide with the flanges **333J** of the lateral indexing rib **331J**.

[0151] However, it should be noted that the invention is not so limited, and in alternate embodiments, the entry sections **282J**, **284J** may be any shape, so long as the entry sections **282J**, **284J** are equal to or larger than the indexing ribs **330J**, **331J**, and therefore allows for the insertion of the indexing ribs **330J**, **331J** into the lateral and longitudinal slots **280J**, **281J**. Further, in alternate embodiments, the retaining sections **283J**, **285J** may be any shape, such as but not limited to, T-shaped, V-shaped, or L-shaped. However, the retaining sections **283J**, **285J** should be sized and shaped similar to the indexing ribs **330J**, **331J**, so that the indexing ribs **330J**, **331J** and the retaining sections **283J**, **285J** may form a tight fit assembly.

[0152] Although not exemplified, the invention of Figures 35-42 is configured such that in order to mate the surgical tool **300J** with the endoscope **200J**, the longitudinal indexing rib **331J** is first inserted into the entry section **284J** of the longitudinal slot **281J**. Next, the longitudinal indexing rib **331J** is slid in the longitudinal direction from the entry section **284J** and into the retaining section **285J** of the longitudinal slot **281J**. Thereafter, the lateral indexing rib **330J** is then inserted into the entry section **282J** of the lateral slot **280J**. Once the lateral indexing rib **330J** is inserted into the entry section **282J** of the lateral slot **280J**, the lateral indexing rib **330J** is slid transversely into the retaining section **283J** of the lateral slot **280J**. Thus, due to the configurations of the longitudinal and lateral slots **280J**, **281J**, the longitudinal indexing rib **331J** is first mated with the longitudinal slot **281J** prior to the lateral indexing rib **330J** being mated with the lateral slot **280J**.

[0153] Since the cross-sectional shapes of the indexing ribs **330J**, **331J** are substantially the same shape and size as the retaining sections **283J**, **285J** (as can be seen in Figures 36, 37, 41, and 42), the flanges **332J**, **333J** of the indexing ribs **330J**, **331J** engage the shoulders **286J**, **287J** of the retaining sections **283J**, **285J** respectively. Specifically, the flange **332J** of the lateral indexing rib **330J** engages the shoulder **286J** of the retaining section **283J** of the lateral slot **280J**, while the flange **333J** of the longitudinal indexing rib **331J** engages the shoulder **287J** of the retaining section **285J** of the longitudinal slot **281J**. This creates a tight fit assembly between the indexing ribs **330J**, **331J** and the slots **280J**, **281J** respectively. Further, once the indexing ribs **330J**, **331J** are mated with the slots **280J**, **281J**, the

endoscope **200J** is mounted to the outer longitudinal surface **304J** of the elongated shaft **301J**.

[0154] When mated, the indexing ribs **330J**, **331J** and slots **280J**, **281J** prevent relative rotational movement and relative transverse movement of the tubular body **250J** relative to the elongated shaft **301J**. Further, it should be noted that the working element (not shown) is located within the viewing field **V-V** of the endoscopic lens **210J**. Such a configuration provides the user with a more consistent and stable view of the working element via the endoscopic lens **210J**.

[0155] In the preferred embodiment, the indexing ribs **330J**, **331J** are constructed from the same material as the surgical instrument **300J** and the slots **280J**, **281J** are constructed from the same material as the endoscope **200J**. However, the invention is not so limited, and in alternate embodiments, the indexing ribs **330J**, **331J** and/or the slots **280J**, **281J** may be constructed from any medical grade material. For instance, in one embodiment, the indexing ribs **330J**, **331J** and/or the slots **280J**, **281J** are constructed from a resilient material for a compression fit.

[0156] In an alternate embodiment of the present invention, the lateral and longitudinal slots **280J**, **281J** further comprise dimples. The dimples would be configured within the retaining portions **283J**, **285J** of the slots **280J**, **281J** and would prevent unintentional removal of the indexing ribs **330J**, **331J** from the slots **280J**, **281J**. Specifically, the dimples would create a tighter fit mating between the indexing ribs **330J**, **331J** and the slots **280J**, **281J** so that the indexing ribs **330J**, **331J** are not unintentionally slid from the retaining portions **283J**, **285J** to the entry sections **282J**, **284J**.

[0157] Generally, the indexing ribs **330J**, **331J** may be conceptualized as a first indexing feature, while the slots **280J**, **281J** may be conceptualized as a second indexing feature. Similar to that which has been discussed above, it should be noted that the first and second indexing features should be corresponding shapes so that they may mate with one another. Further, in alternate embodiments of the present invention, the first indexing feature may be slots, while the second indexing feature is indexing ribs. Therefore, the invention is not limited to whether the first or second indexing features are ribs and slots respectively.

[0158] Further, although the tubular body **250J** of the endoscope **200J** does not comprise a block (as shown above with reference to Figures 32-34), the invention is not so limited, and in alternate embodiments, the block may be included in the tubular body **250J** of endoscope

**200J.** In such embodiments, the endoscopic lens **210J** is will be diverged away from the outer longitudinal surface **304J** of the elongated shaft **301J** of the surgical tool **300J**. Moreover, although the outer longitudinal surface **304J** of the elongated shaft **301J** of the surgical tool **300J** does not comprise a protuberance (as shown above with reference to Figures 20-21 and 23-25), the invention is not so limited, and in alternate embodiments, the protuberance may be included in the outer longitudinal surface **304J** of the elongated shaft **301J**. In such embodiments, the endoscopic lens **210J** will be diverged away from the outer longitudinal surface **304J** of the elongated shaft **301J** of the surgical tool **300J**.

[0159] Finally, it should be noted that any of the embodiments of surgical tools and endoscopes discussed above may be used as a surgical apparatus in a surgical system in conjunction with a microscope and a display, similar to that discussed above with reference to Figure 1. Therefore, the surgical instrument **300** and the endoscope **200** of the endoscope/operating microscope assembly system (or surgical system) **1000** of Figure 1 may be substituted out with any of the alternate surgical instruments **300X, A-J** and endoscopes **200X, A-J** discussed above with reference to Figures 20-42.

[0160] While the embodiment of the present invention has been described with reference to the accompanying drawings, it can be understood by those skilled in the art that the present invention can be embodied in other specific forms without departing from its spirit or essential characteristics. Therefore, the foregoing embodiments and advantages are merely exemplary and are not to be construed as limiting the present invention. The present teaching can be readily applied to other types of apparatuses. The description of the foregoing embodiments is intended to be illustrative, and not to limit the scope of the claims. Many alternatives, modifications, and variations will be apparent to those skilled in the art. In the claims, means-plus-function clauses are intended to cover the structures described herein as performing the recited function and not only structural equivalents but also equivalent structures.

## Claims

What is claimed is:

1. A surgical apparatus comprising:

a surgical instrument comprising an elongated shaft extending along a longitudinal axis from a proximal end to a distal end, a working element coupled to the distal end of the elongated shaft for manipulating tissue;

an endoscope having a tubular body including an image fiber, an endoscopic lens coupled to a distal end of the tubular body and operably coupled to the image fiber, the endoscopic lens defining a viewing field about a central axis; and

the endoscope mounted to the elongated shaft of the surgical instrument, the endoscopic lens protruding from an outer longitudinal surface of the elongated shaft, the central axis of the viewing field being oblique to the longitudinal axis of the elongated shaft and intersecting the outer longitudinal surface, the working element located within the viewing field and separated from the central axis by a distance.

2. The surgical apparatus of claim 1 wherein the central axis of the viewing field is divergent from the working element.

3. The surgical apparatus of claim 1 wherein the endoscope is mounted to the outer longitudinal surface of the elongated shaft.

4. The surgical apparatus of claim 1 wherein the tubular body comprises a base portion and a protruding portion oblique to the base portion, the protruding portion comprising the distal end of the tubular body and protruding from the outer longitudinal surface of the elongated shaft.

5. The surgical apparatus of claim 1 wherein the elongated shaft is substantially rigid.

6. The surgical apparatus of claim 1 wherein the central axis of the viewing field is substantially coplanar with the longitudinal axis of the elongated shaft.

7. The surgical apparatus of claim 1 wherein the surgical instrument is a micro-surgical instrument.

8. The surgical apparatus of claim 7 wherein the micro-surgical instrument is selected from a group consisting of suction, dissectors, forceps, and bipolar coagulators.
9. The surgical apparatus of claim 1 further comprising a coupling mechanism securing the endoscope to the elongated shaft so that the endoscopic lens is substantially stationary relative to the elongated shaft.
10. The surgical apparatus of claim 9 wherein the coupling mechanism comprises:
  - a protuberance extending from the outer longitudinal surface of the elongated shaft in a first transverse direction, the protuberance located a first longitudinal distance from the distal end of the elongated shaft; and
  - a retaining member securing the endoscope to the elongated shaft, the retaining member located a second longitudinal distance from the distal end of the elongated shaft adjacent the protuberance, the second distance greater than the first distance, the retaining member exerting a force on the tubular body in a second transverse direction opposite the first transverse direction.
11. The surgical apparatus of claim 10 wherein the protuberance acts a fulcrum on the tubular body of the endoscope that forces a portion of the endoscope to diverge from the outer longitudinal surface of the elongated shaft.
12. The surgical apparatus of claim 10 wherein the coupling mechanism comprises an arch structure protruding from the outer longitudinal surface of the elongate shaft, the arch structure defining a passageway for retaining a portion of the endoscope.
13. The surgical apparatus of claim 12 wherein the passageway comprises a floor that diverges from the outer longitudinal surface of the elongated shaft moving toward the distal end of the elongated shaft.
14. The surgical apparatus of claim 12 wherein the coupling mechanism further comprises:
  - a protuberance extending from the outer longitudinal surface of the elongated shaft, the protuberance located adjacent an exit of the passageway;

the endoscope extending through the passageway and over the protuberance, the protuberance causing the tubular body of the endoscope to diverge from the outer longitudinal surface of the elongated shaft.

15. The surgical apparatus of claim 1 wherein the elongated shaft comprises a first indexing feature and the tubular body of the endoscope comprises a second indexing feature, and wherein the first and second indexing features mate with one another so as to prevent rotation of the tubular body relative to the elongated shaft.

16. The surgical instrument of claim 1 wherein the central axis of the viewing field is oriented at an oblique angle between  $5^{\circ}$  to  $45^{\circ}$  to the longitudinal axis of the elongated shaft.

17. A surgical apparatus comprising:

a surgical instrument comprising an elongated shaft extending along a longitudinal axis from a proximal end to a distal end, a working element coupled to the distal end of the elongated shaft for manipulating tissue, the elongated shaft comprising a first indexing feature;

an endoscope having a tubular body including an image fiber, an endoscopic lens coupled to a distal end of the tubular body and operably coupled to the image fiber, the endoscopic lens defining a viewing field about a central axis, the tubular body comprising a second indexing feature; and

the endoscope mounted to the elongated shaft of the surgical instrument so that the first and second indexing features mate with one another so as to prevent relative rotation between the elongated shaft and the tubular body, the working element located within the viewing field.

18. The surgical apparatus of claim 17 wherein one of the first or second indexing features is a longitudinal rib and the other of the first or second indexing features is a longitudinal slot.

19. The surgical apparatus of claim 17 wherein the first indexing feature comprises a first rib extending in a first direction and a second rib extending in a second direction that is different than the first direction, the second indexing feature comprising a first slot extending in the first direction and a second slot extending in the second direction, the first rib mating with the first slot and the second rib mating with the second slot.

20. A surgical system comprising:
- a surgical apparatus comprising:
    - a surgical instrument comprising an elongated shaft and a working element coupled to a distal end of the elongated shaft for manipulating tissue;
    - an endoscope having a tubular body including an image fiber, an endoscopic lens coupled to a distal end of the tubular body and operably coupled to the image fiber, the endoscopic lens defining a viewing field about a central axis; and
    - the endoscope mounted to the elongated shaft of the surgical instrument so that the working element is located within the viewing field;
  - a microscope comprising an ocular lens; and
  - a display displaying an image perceived by the ocular lens and an image perceived by the endoscopic lens.
21. The surgical system of claim 20 wherein the endoscopic lens protrudes from an outer longitudinal surface of the elongated shaft, the central axis of the viewing field being oblique to a longitudinal axis of the elongated shaft and intersecting the outer longitudinal surface, the working element located within the viewing field and separated from the central axis by a distance.
22. The surgical system of claim 20 wherein the central axis of the viewing field is oriented at an oblique angle between 5° to 45° to the longitudinal axis of the elongated shaft
23. The surgical system of claim 20 wherein the microscope comprises the display, wherein the image perceived by the ocular lens is displayed in an ocular viewing area of the display and the image perceived by the endoscopic lens is displayed in an endoscopic viewing area of the display.
24. The surgical system of claim 23 wherein the ocular viewing area and the endoscopic viewing area are simultaneously displayed on the display.
25. The surgical system of claim 23 wherein the ocular viewing area and the endoscopic viewing area are consecutively displayed on the display in response to a switching signal.

26. The surgical system of claim 23 wherein the endoscopic viewing area overlays the ocular viewing area.
27. The surgical system of claim 20 wherein the surgical instrument is a micro-surgical instrument.
28. The surgical system of claim 20 wherein the image perceived by the ocular lens is non-coplanar with the image perceived by the endoscopic lens.
29. The surgical system of claim 20 wherein the microscope comprises at least two oculars.
30. A method of performing surgery comprising:  
    mounting an endoscope to a micro-surgical instrument so that a working element of the micro-surgical instrument is located within a viewing field of the endoscope;  
    positioning a microscope so that an ocular lens of the microscope perceives a surgical site;  
    manipulating tissue within the surgical site using the working element of the micro-surgical instrument; and  
    displaying, in a display, an image perceived by the endoscope and an image perceived by the ocular lens.
31. The method of claim 31 wherein the surgical site is selected from a group consisting of an intracranial surgical site and a spinal surgical site.

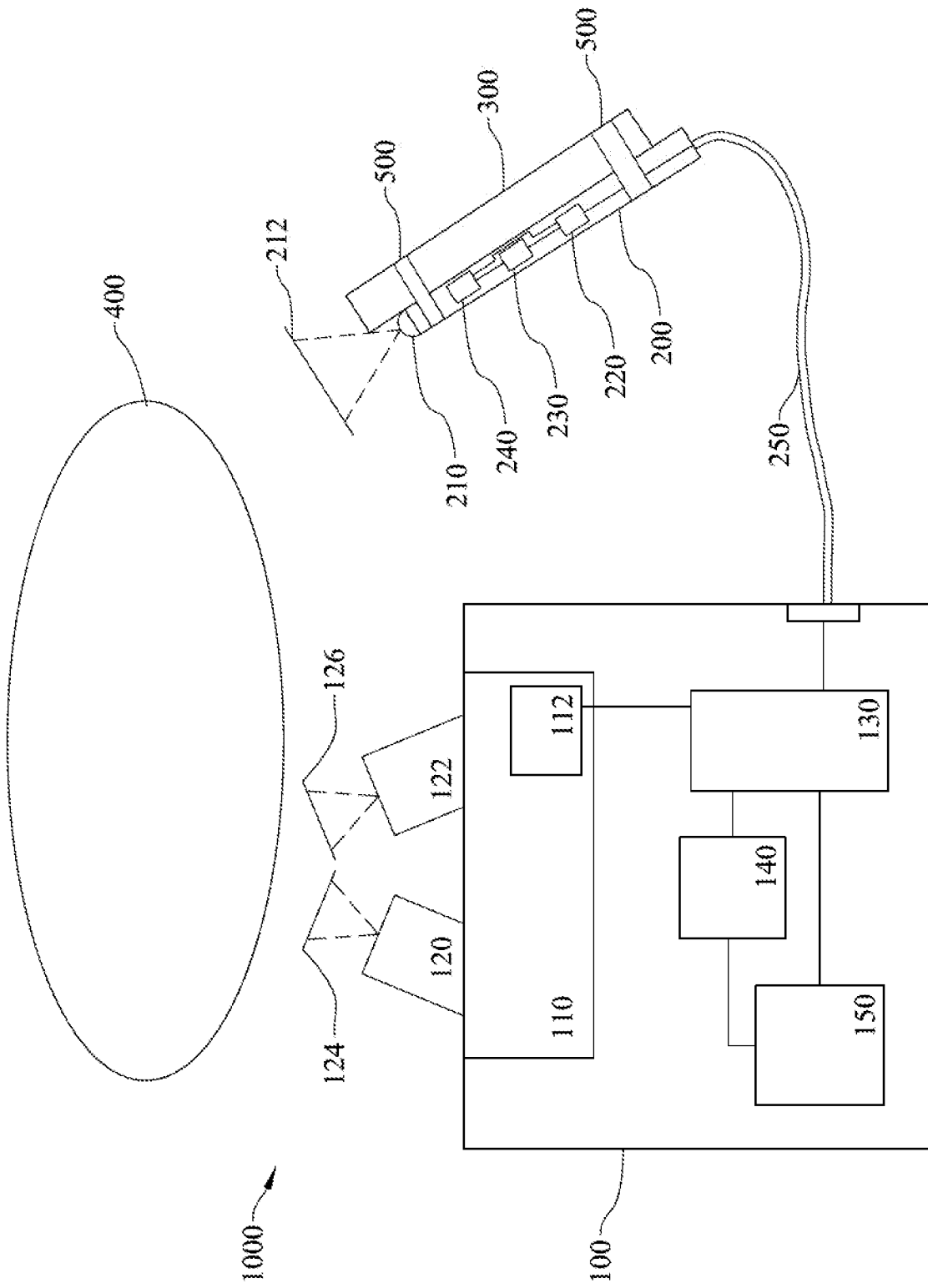

FIGURE 1

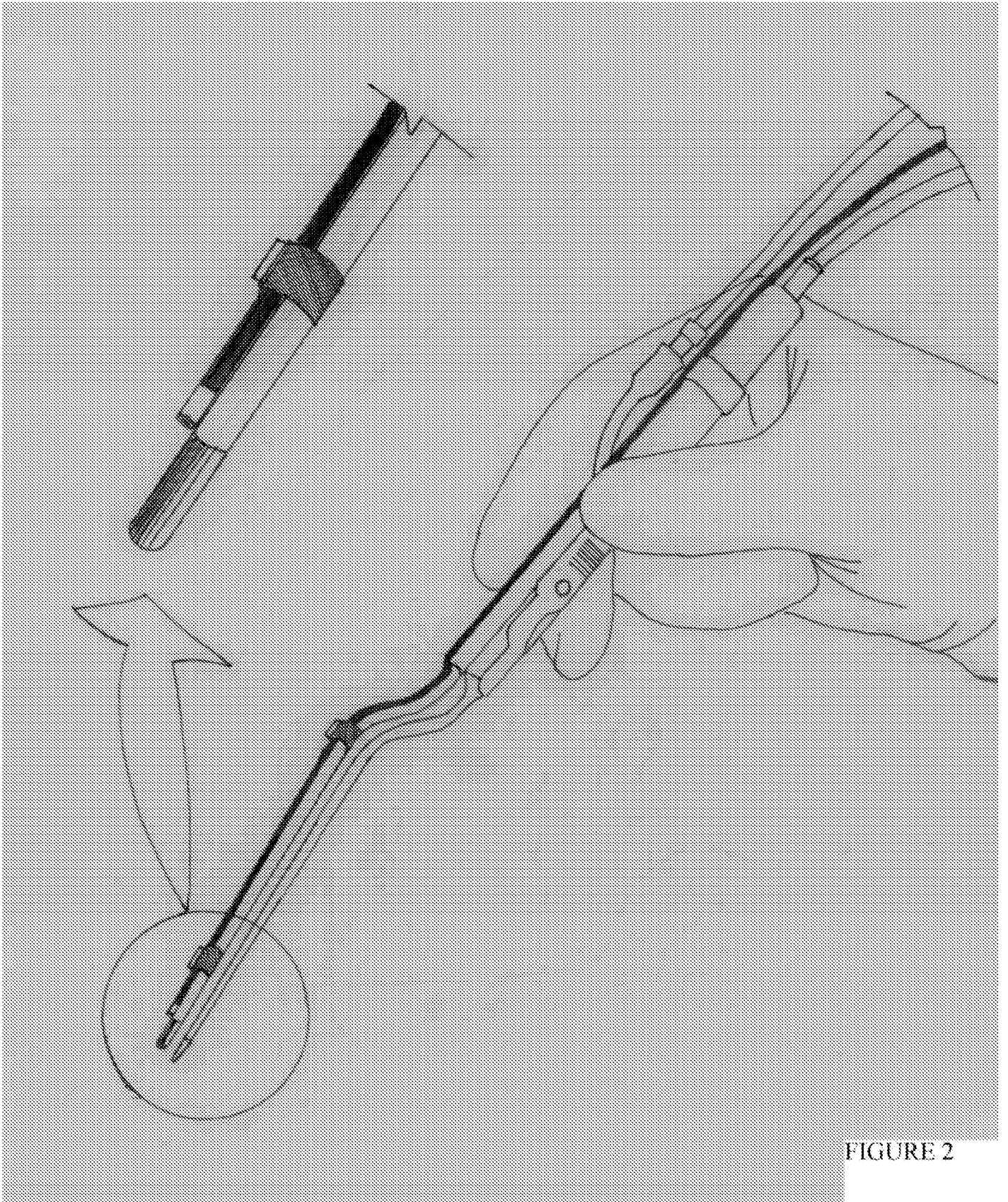

FIGURE 2

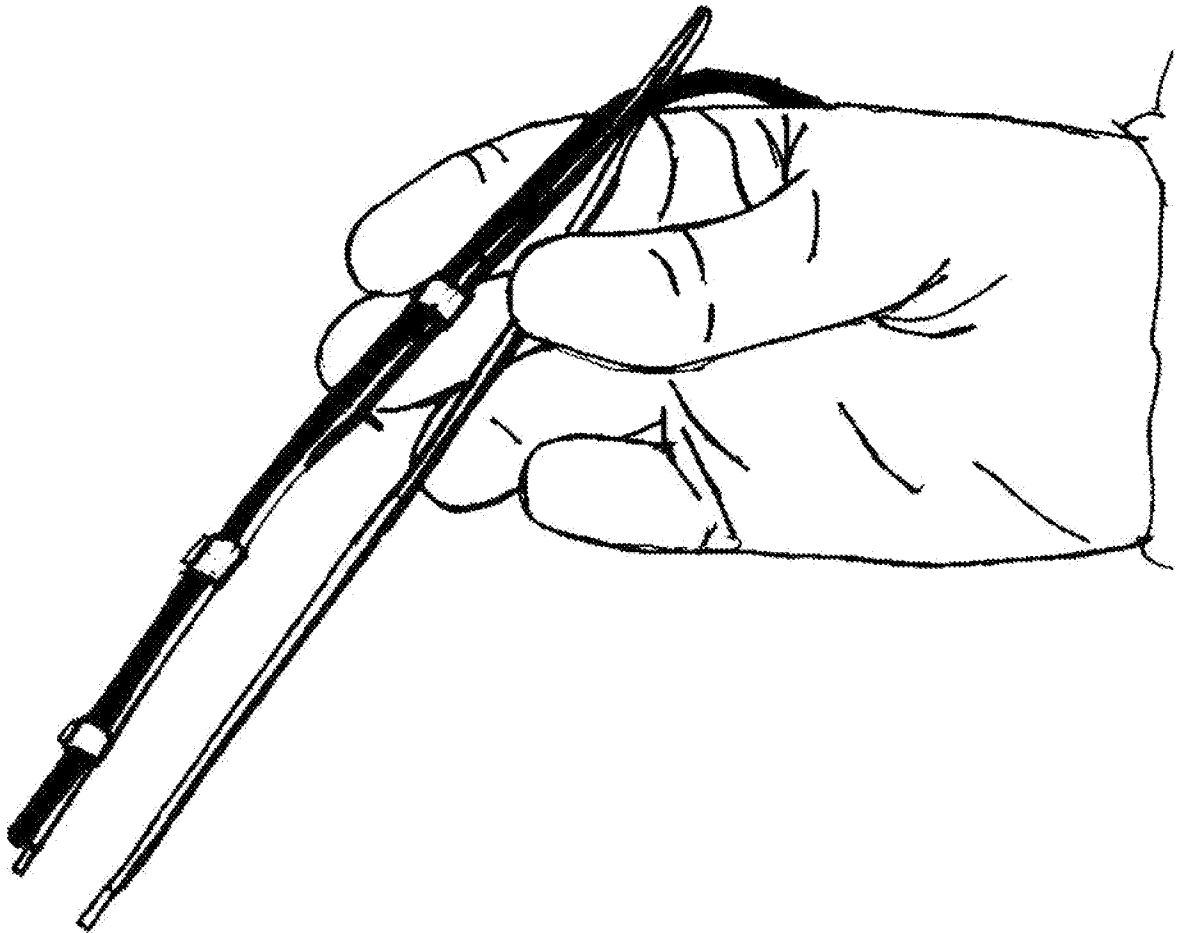

FIGURE 3

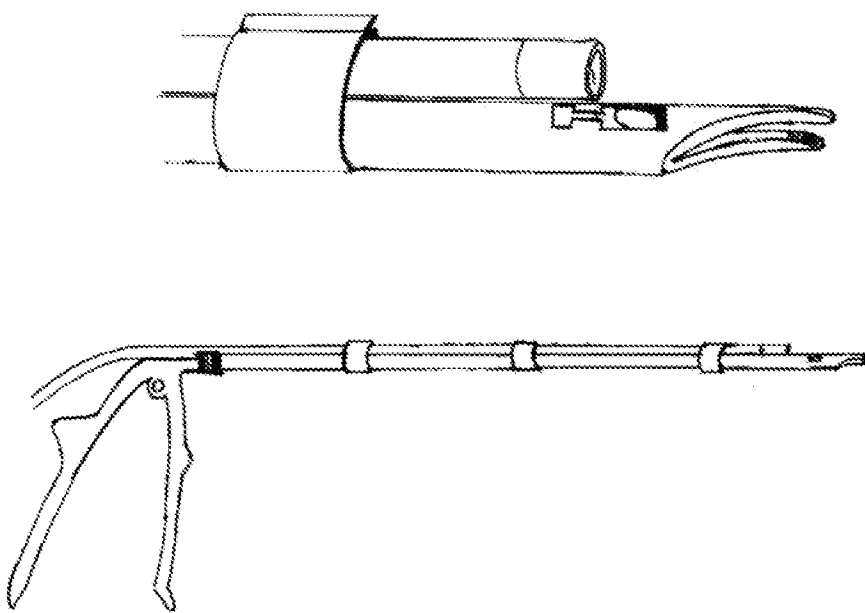

FIGURE 4

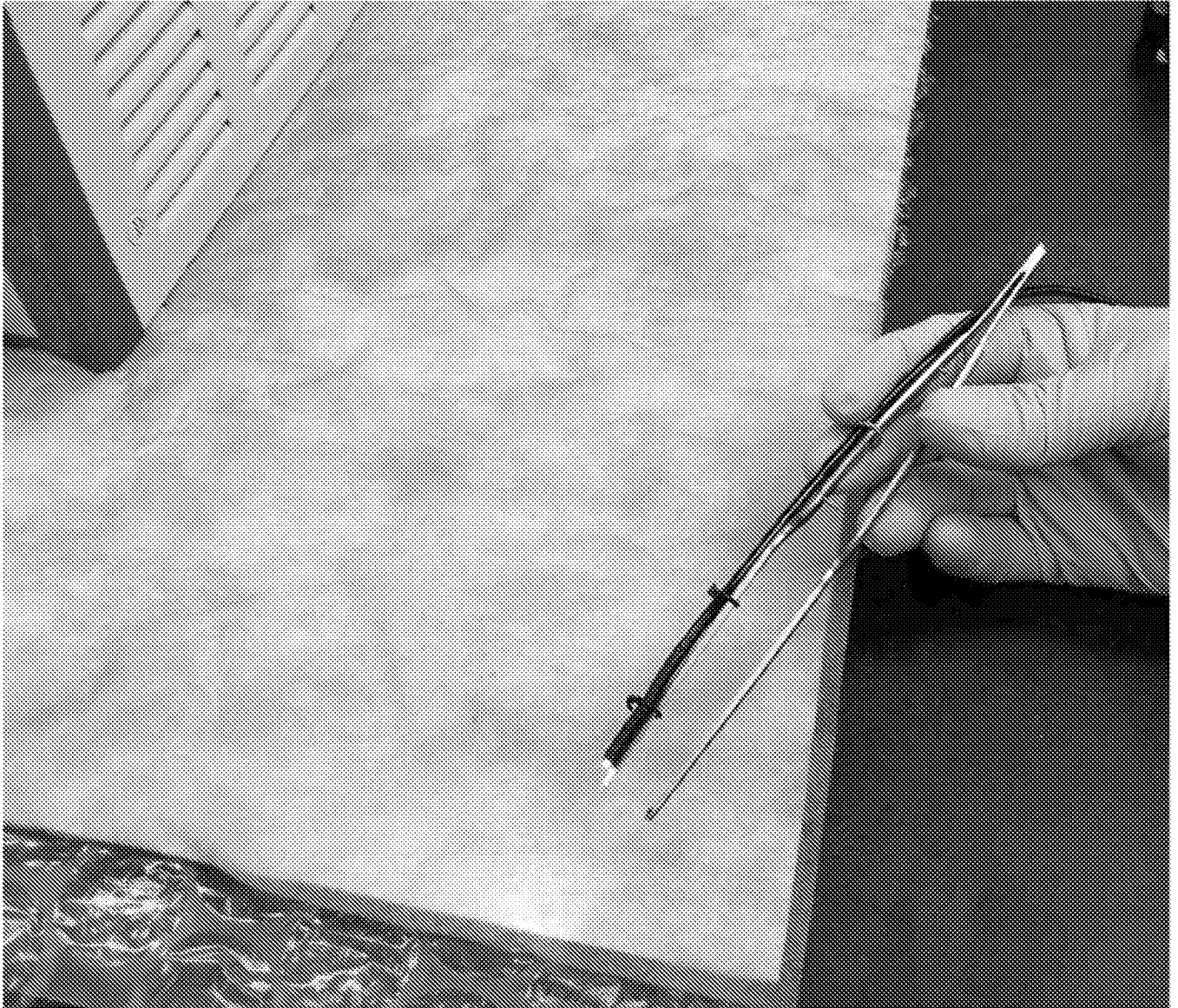

FIGURE 5

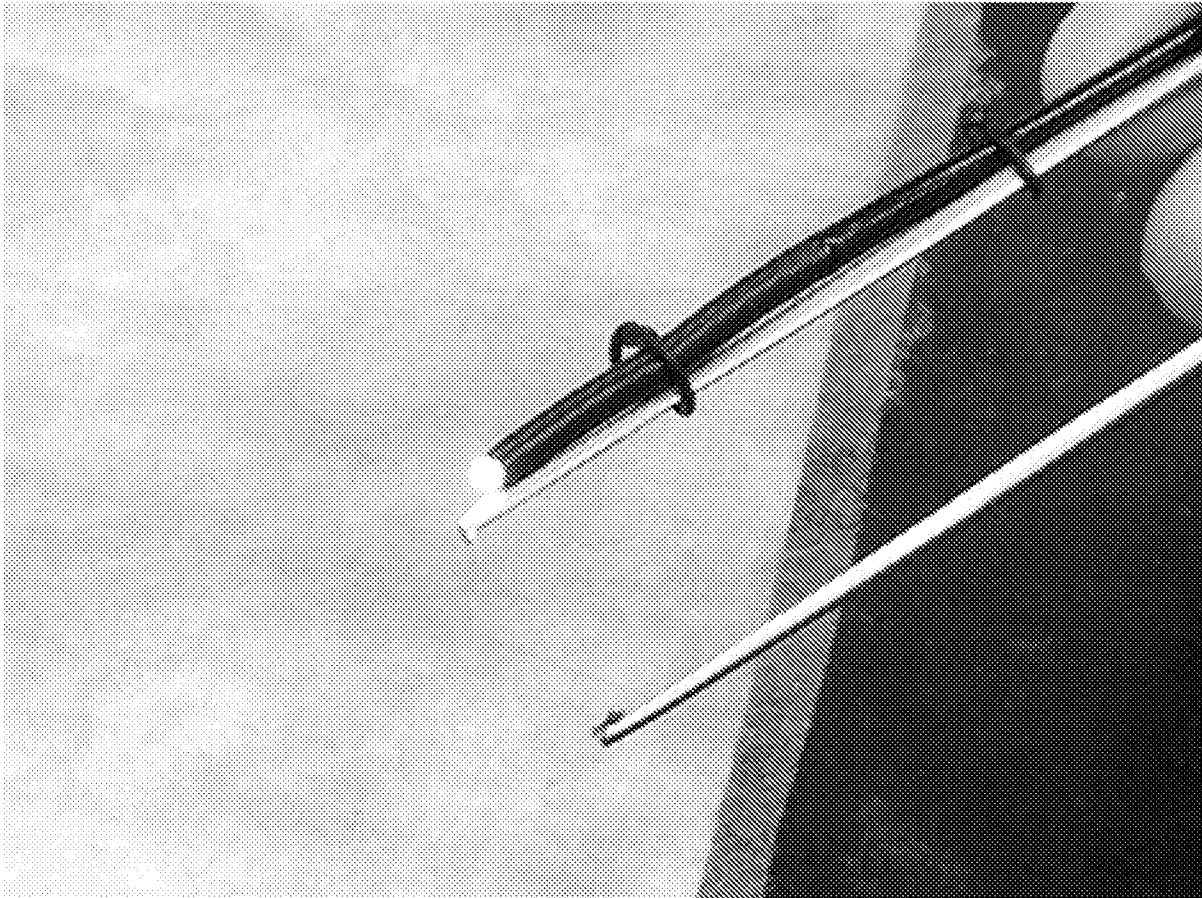

FIGURE 6

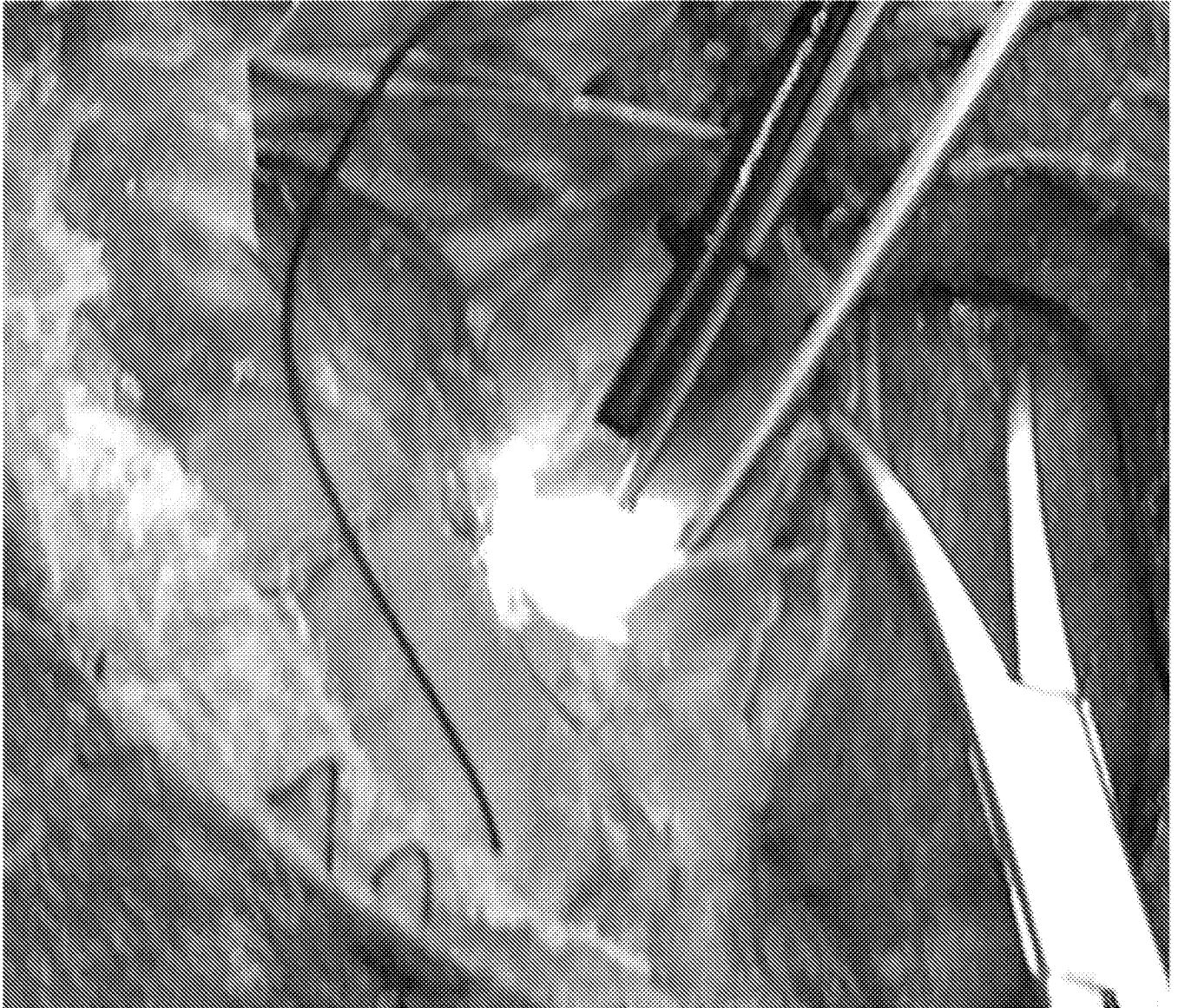

FIGURE 7

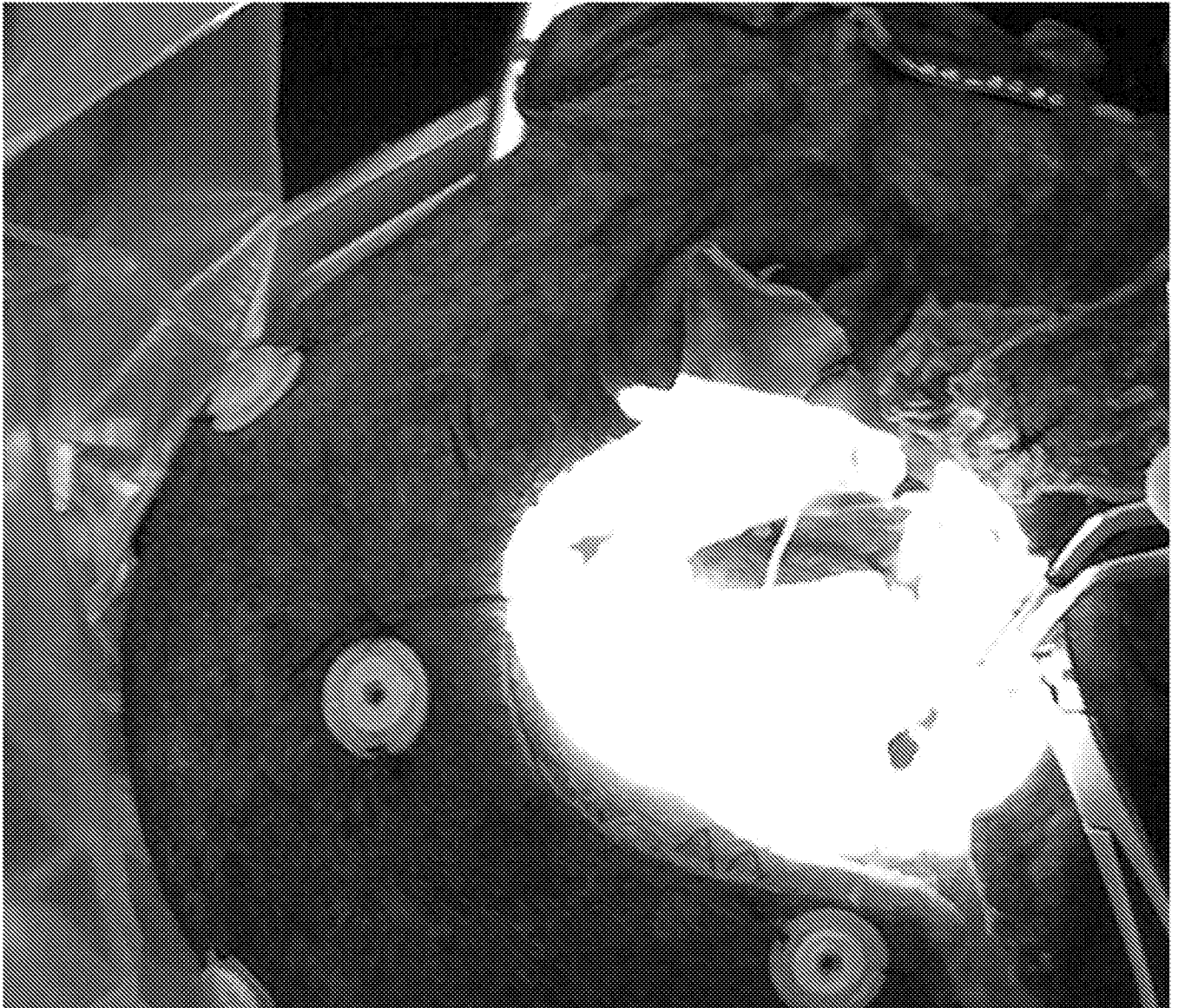

FIGURE 8

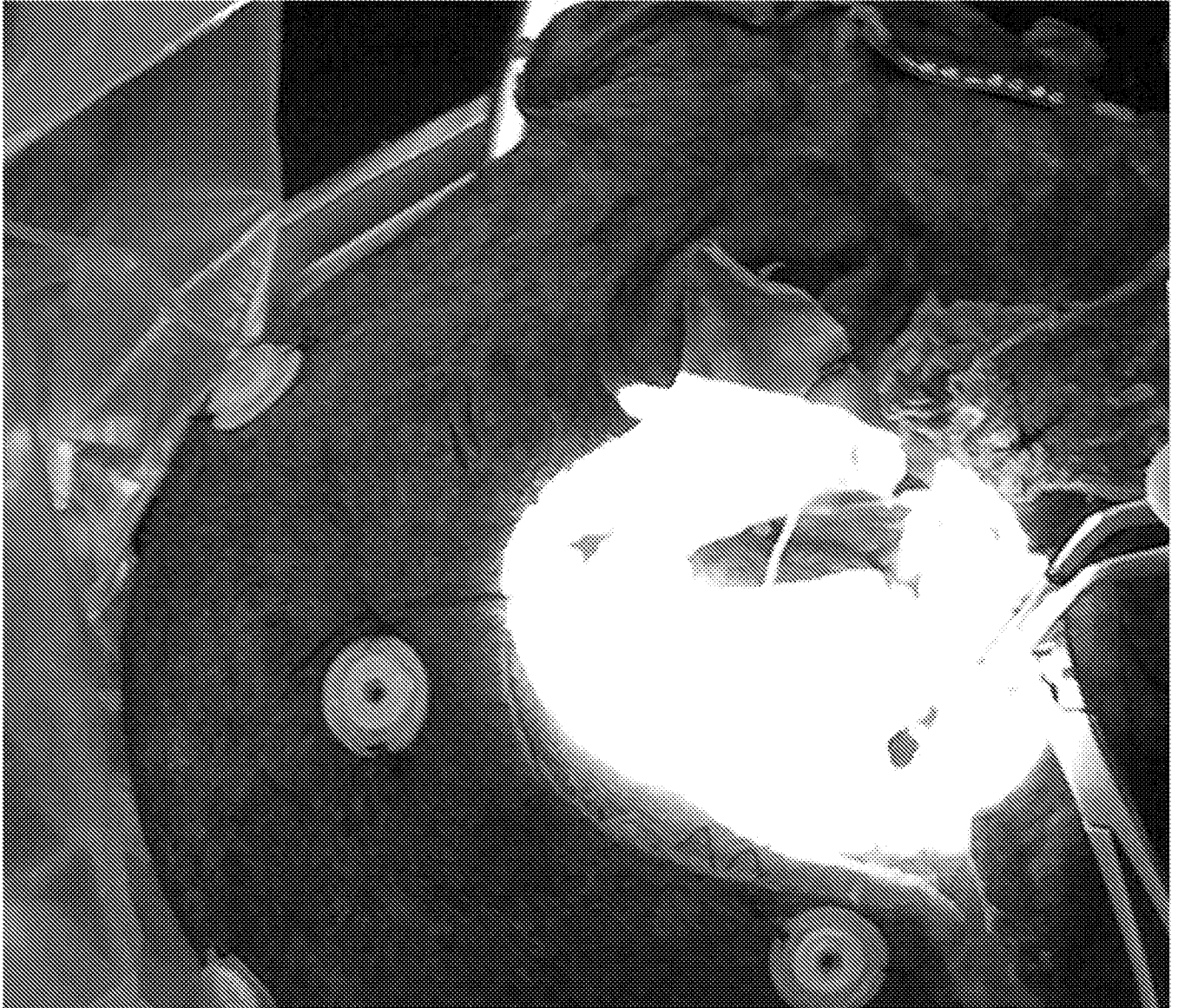

FIGURE 9



FIGURE 10

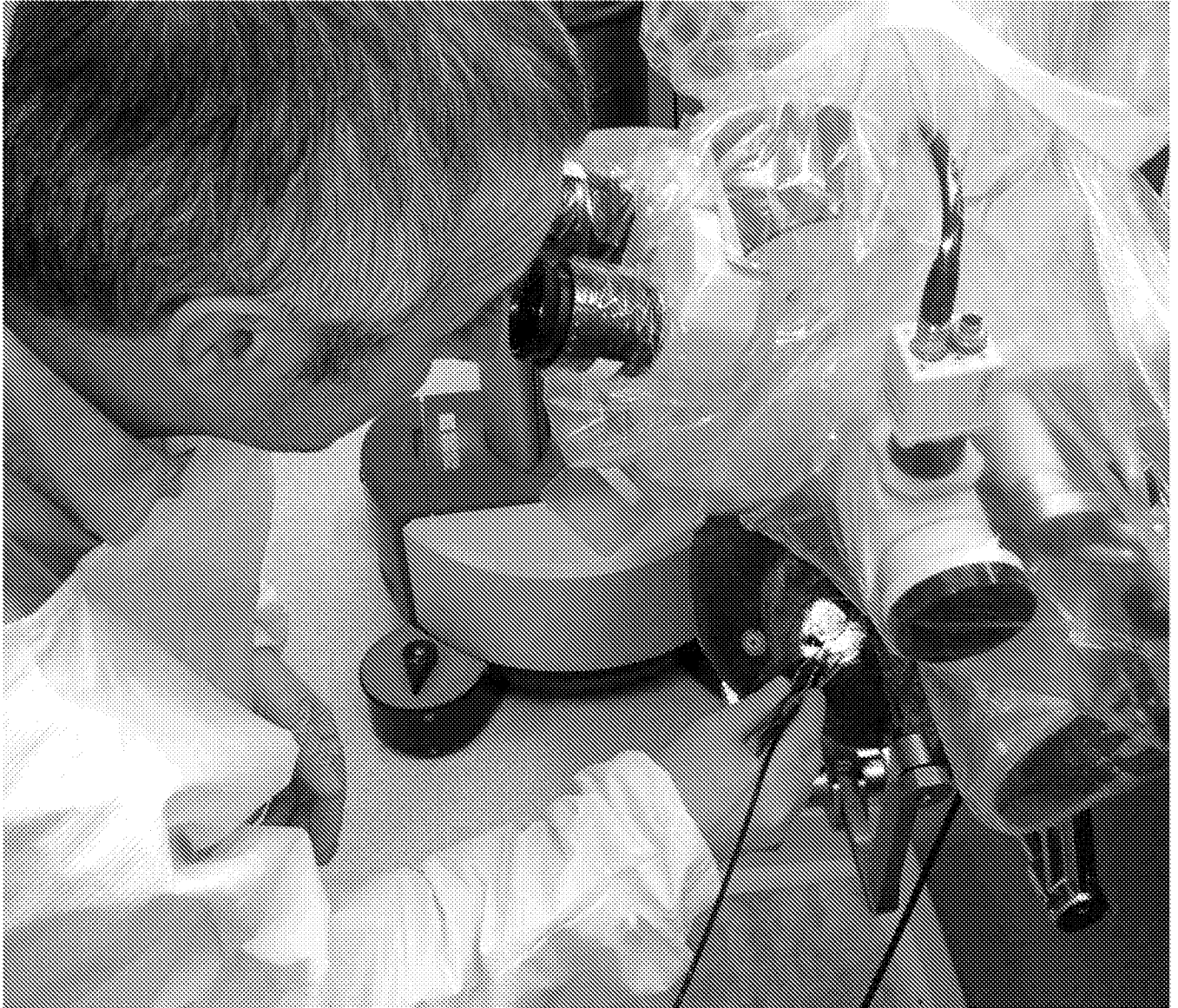

FIGURE 11



FIGURE 12



FIGURE 13

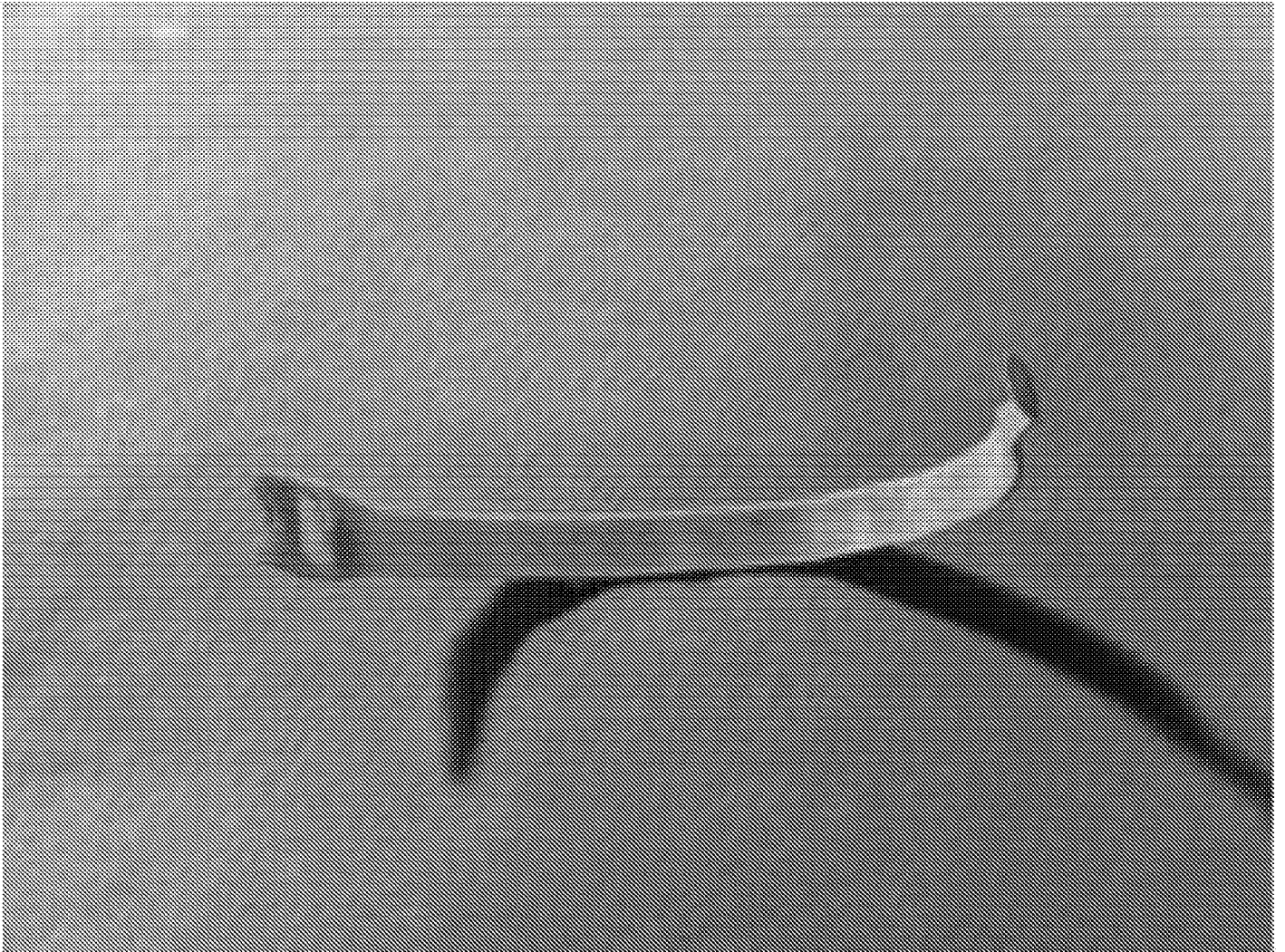

FIGURE 14

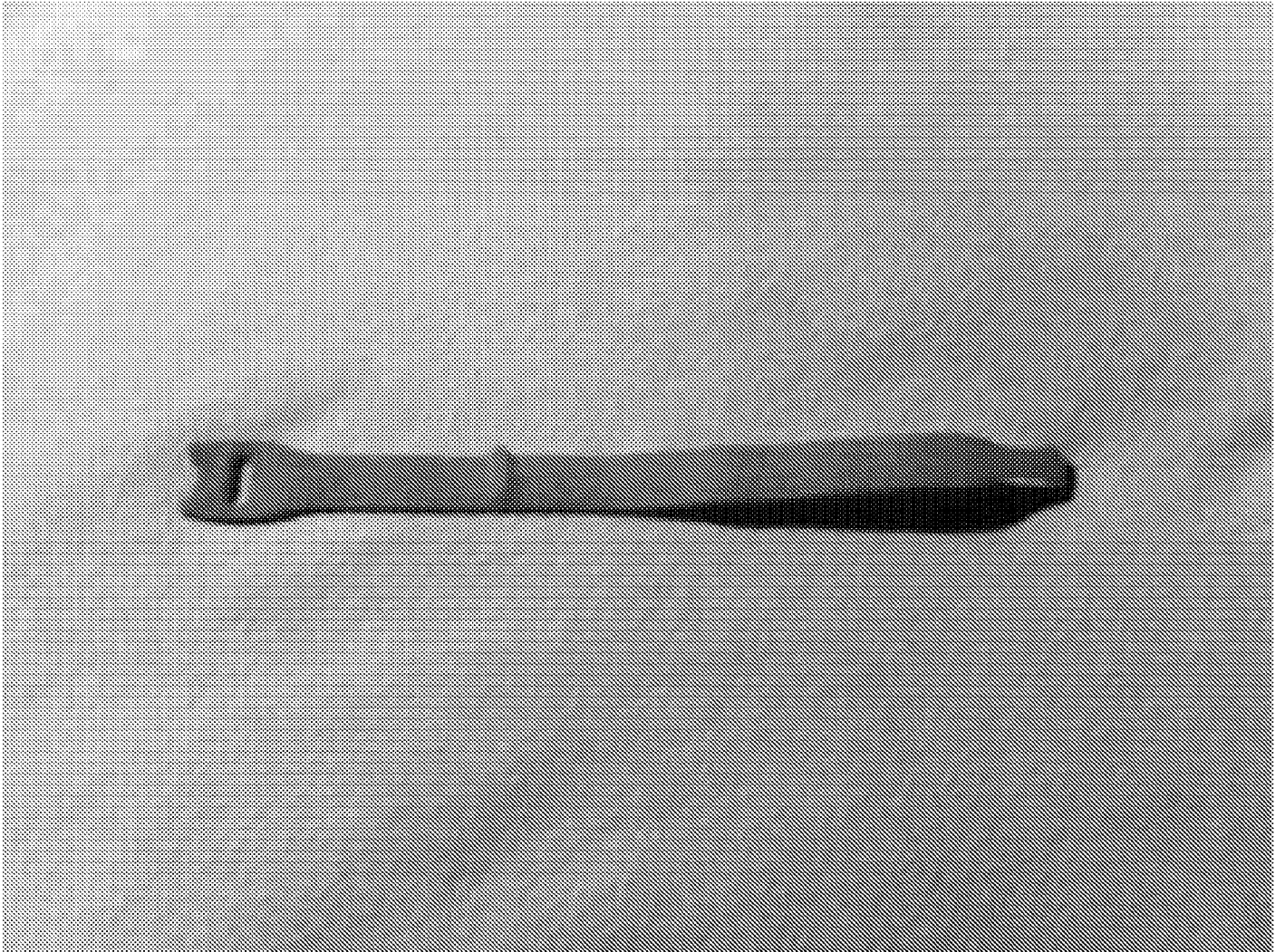

FIGURE 15



FIGURE 16

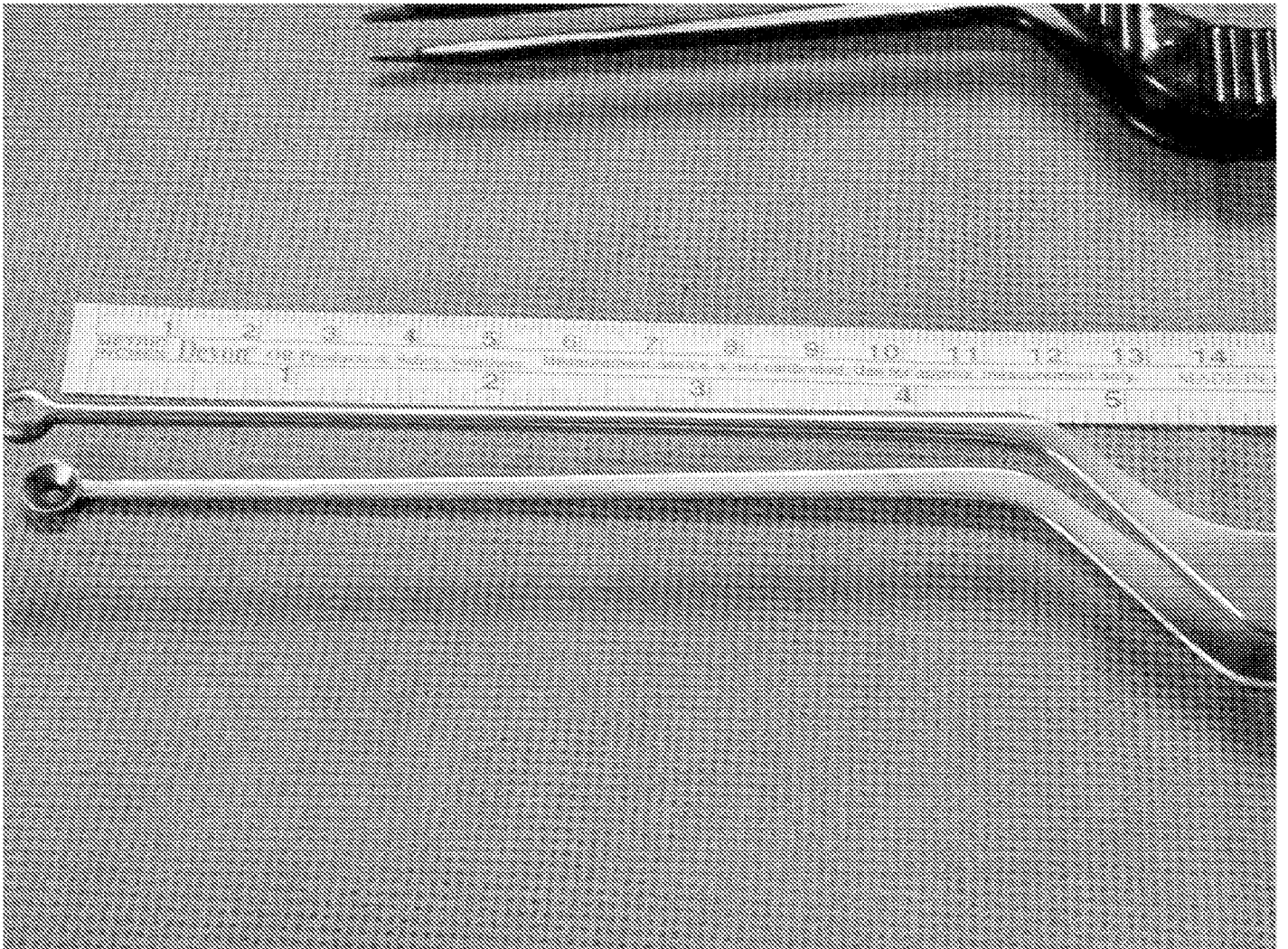

FIGURE 17

FIG. 18

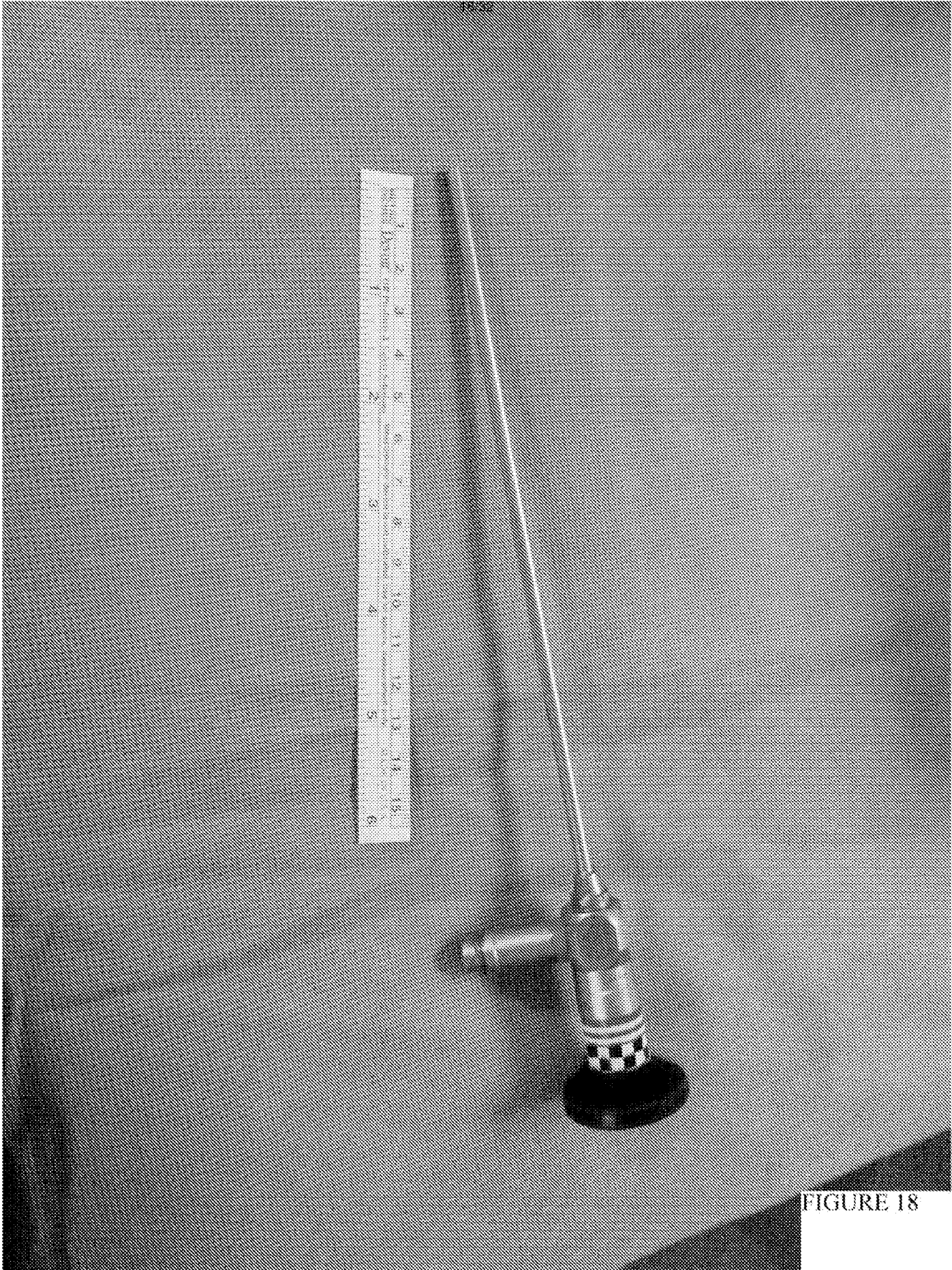

FIGURE 18

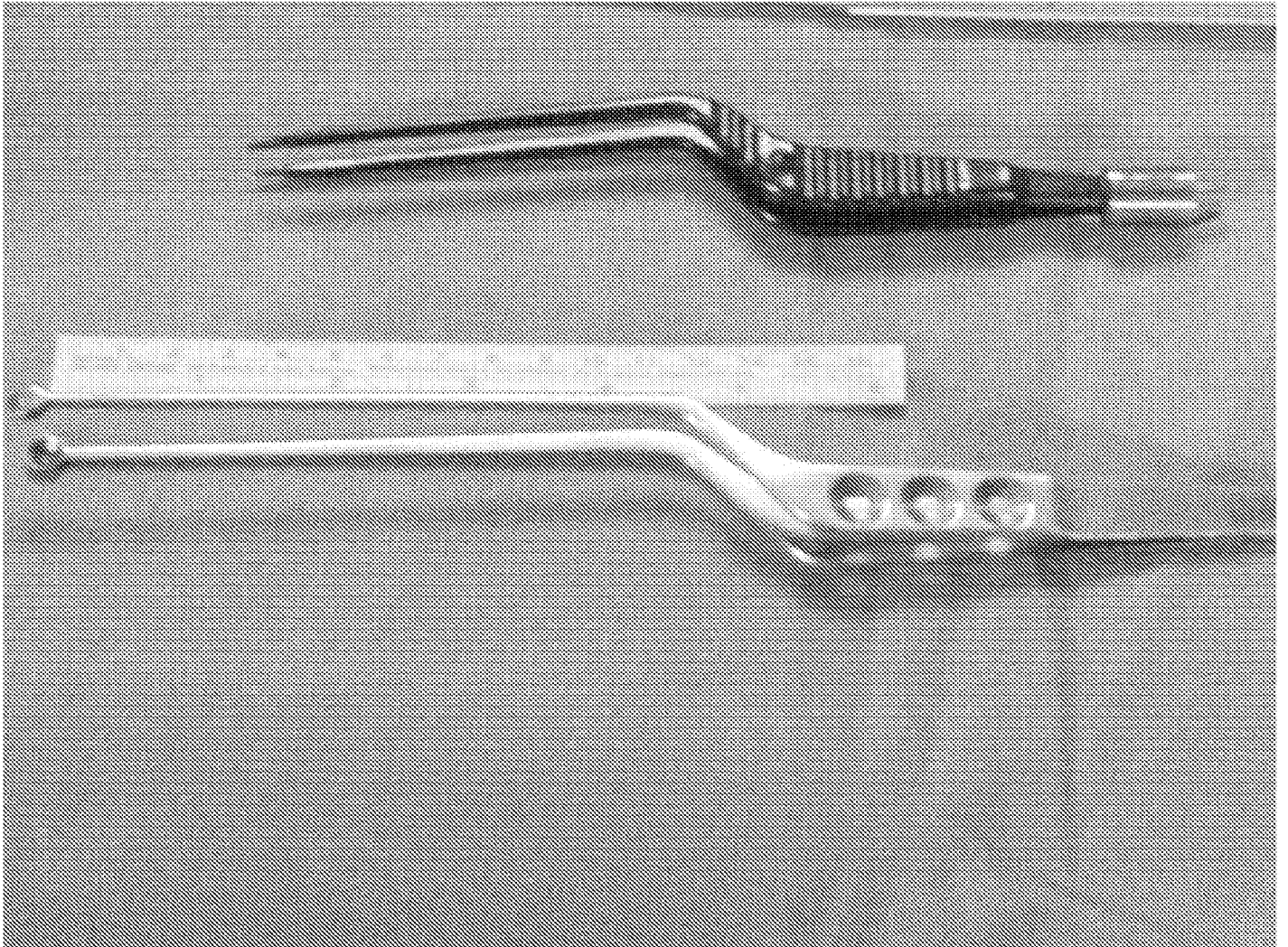

FIGURE 19

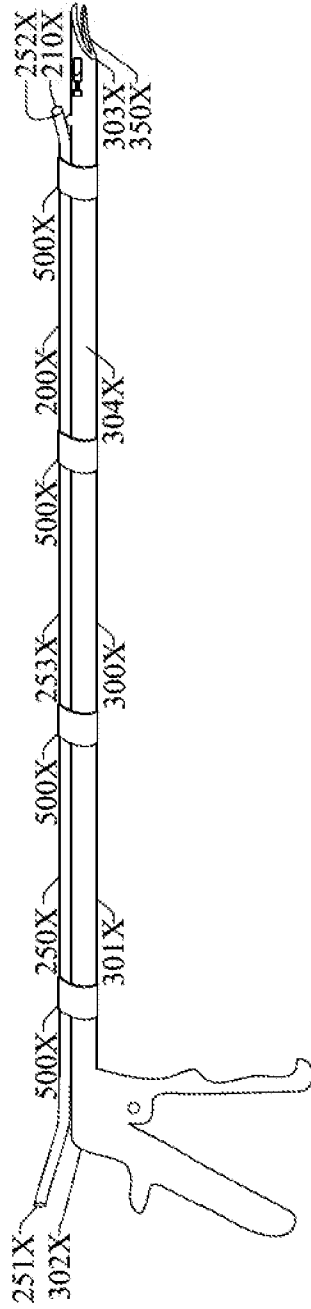

FIGURE 20

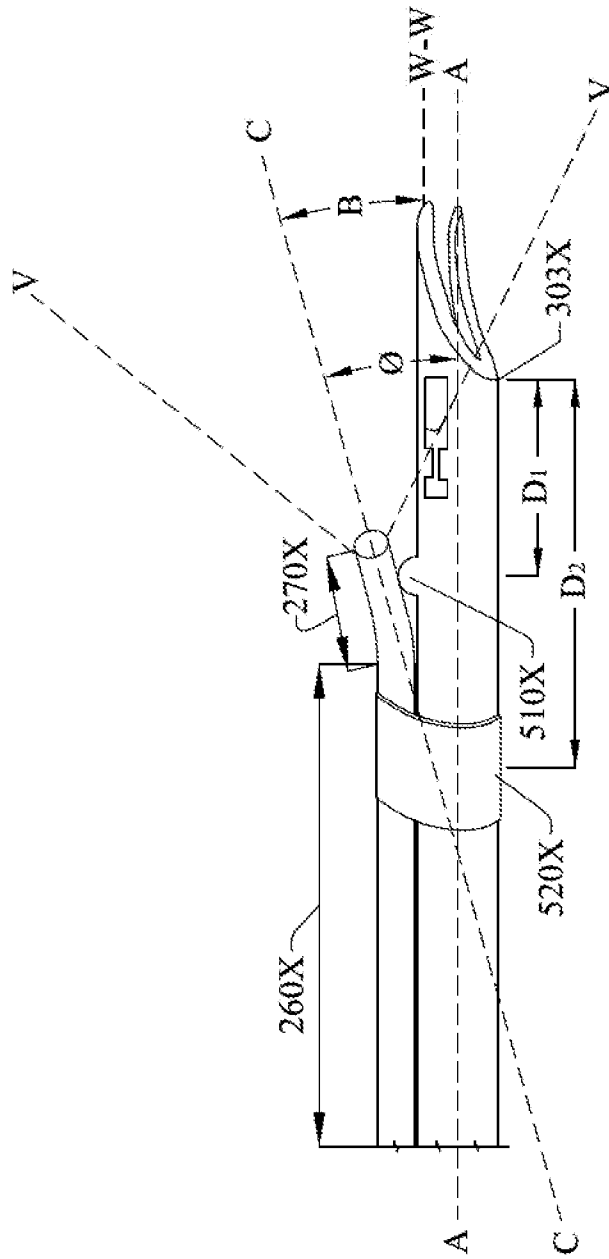

FIGURE 21

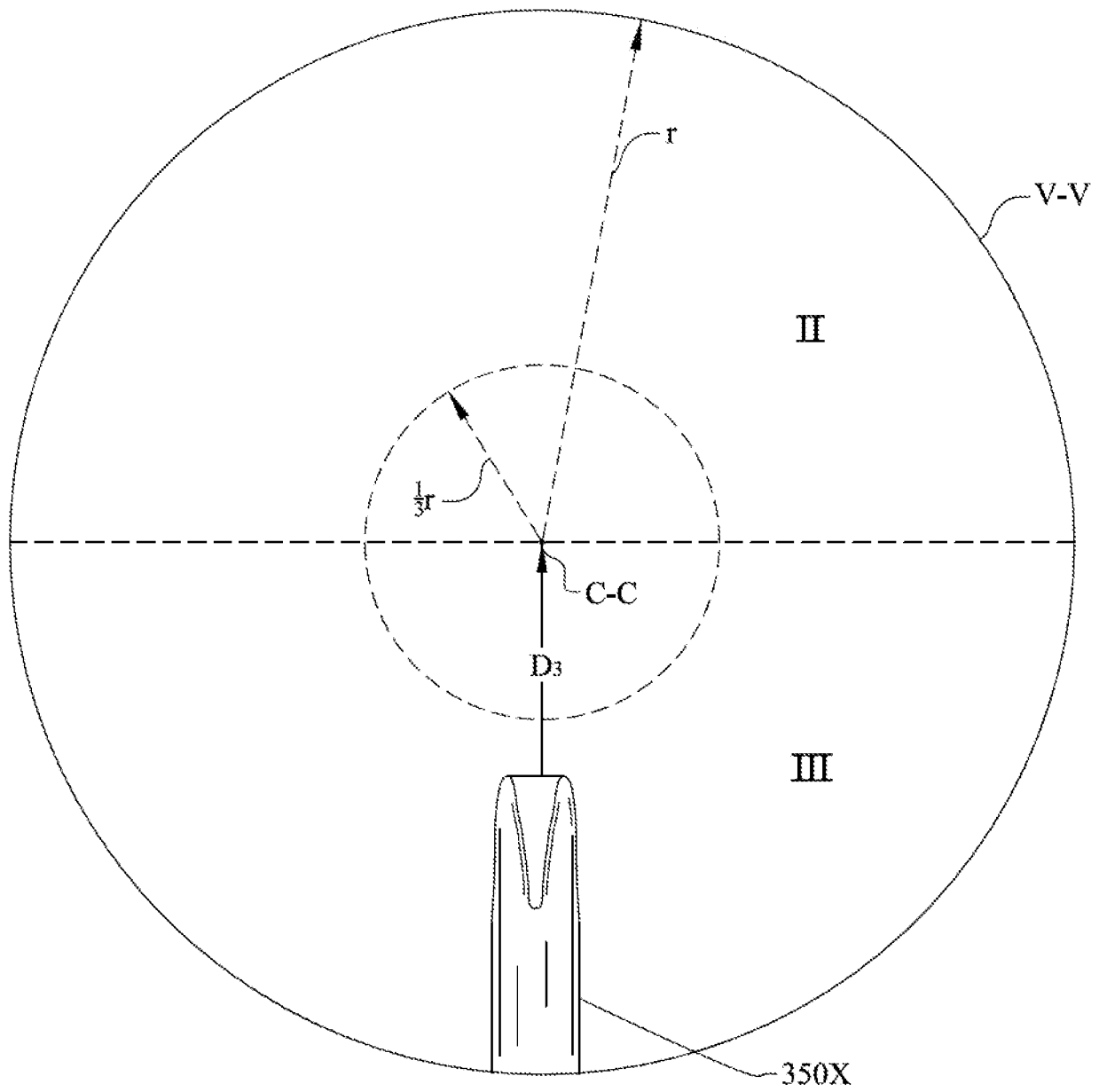

FIGURE 22

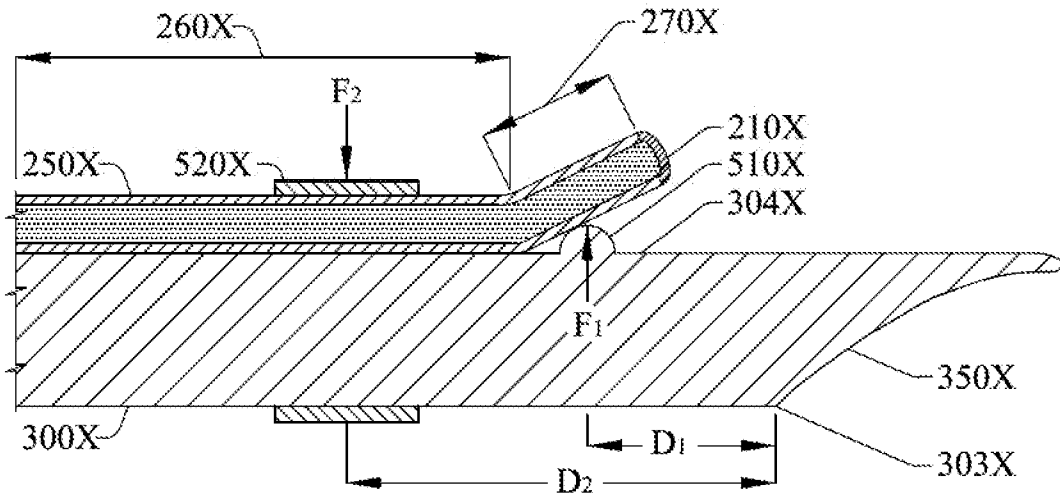

FIGURE 23

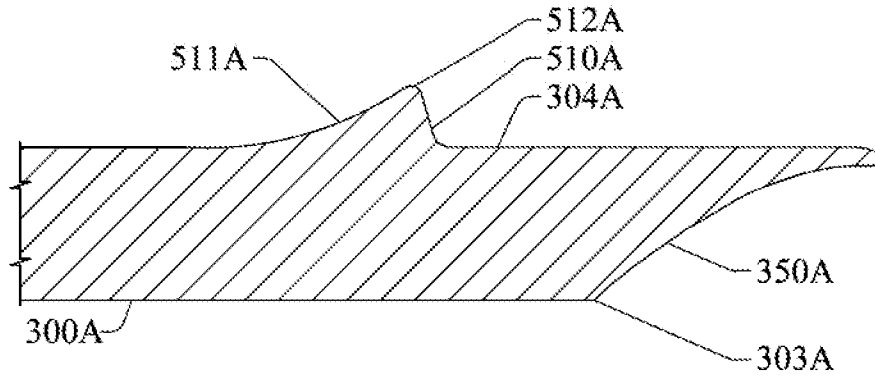

FIGURE 24

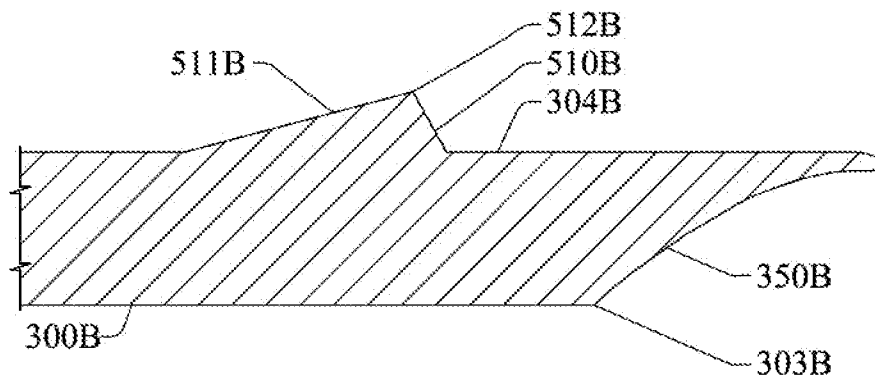

FIGURE 25

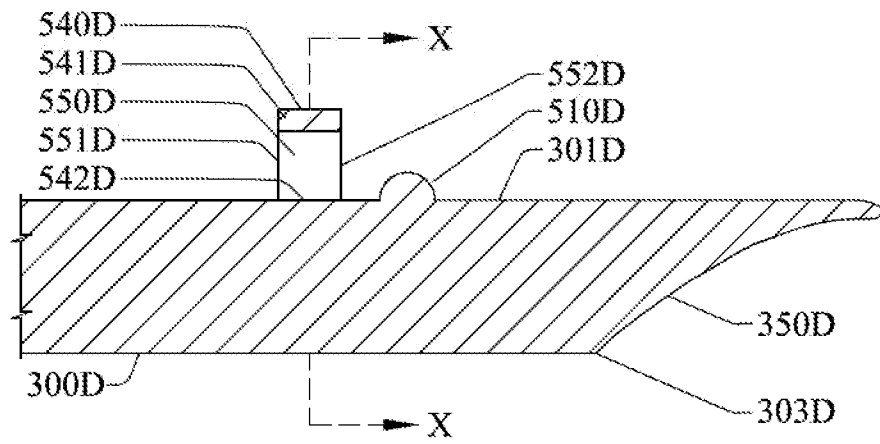

FIGURE 26

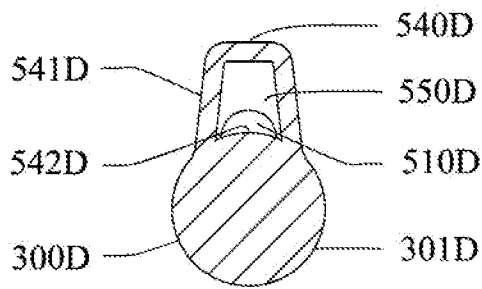

FIGURE 27

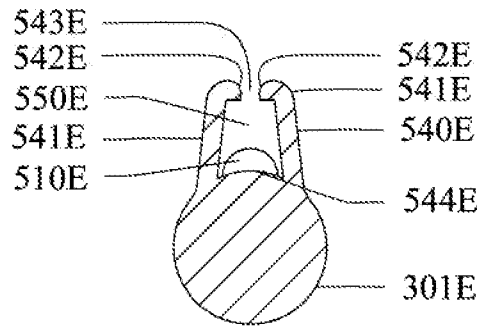

FIGURE 28

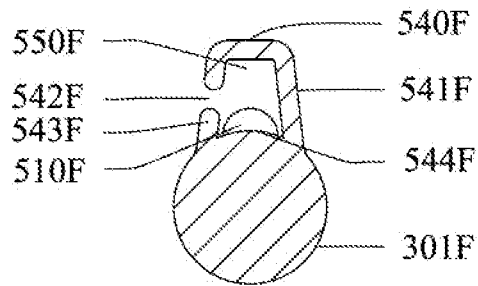

FIGURE 29

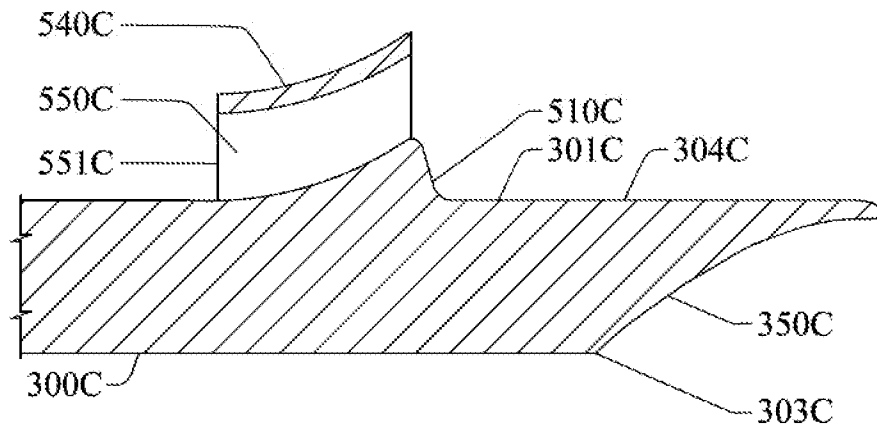

FIGURE 30

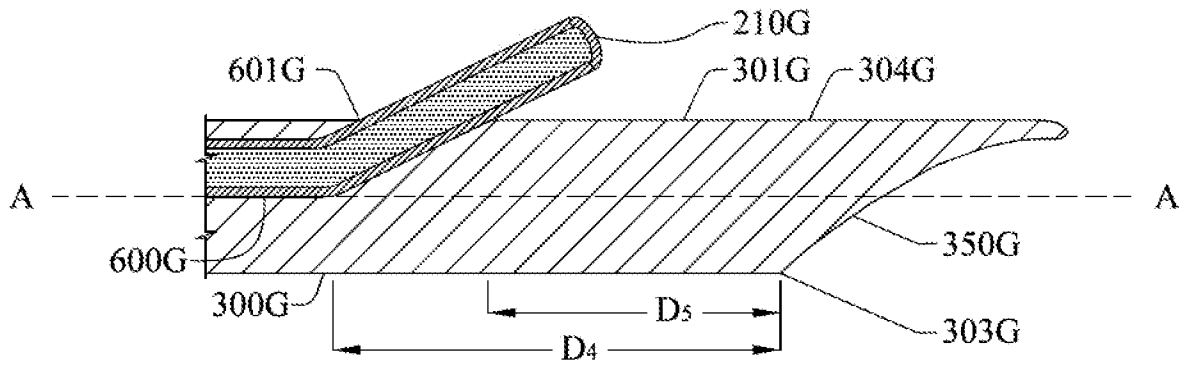

FIGURE 31

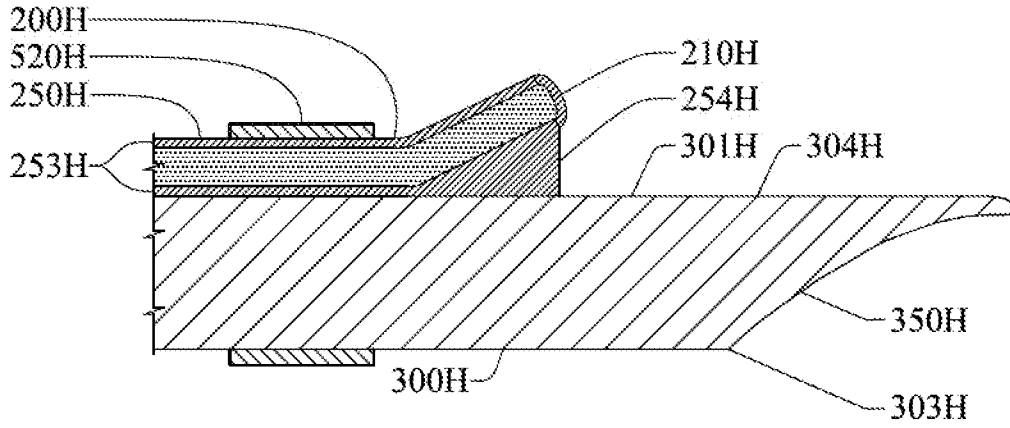

FIGURE 32

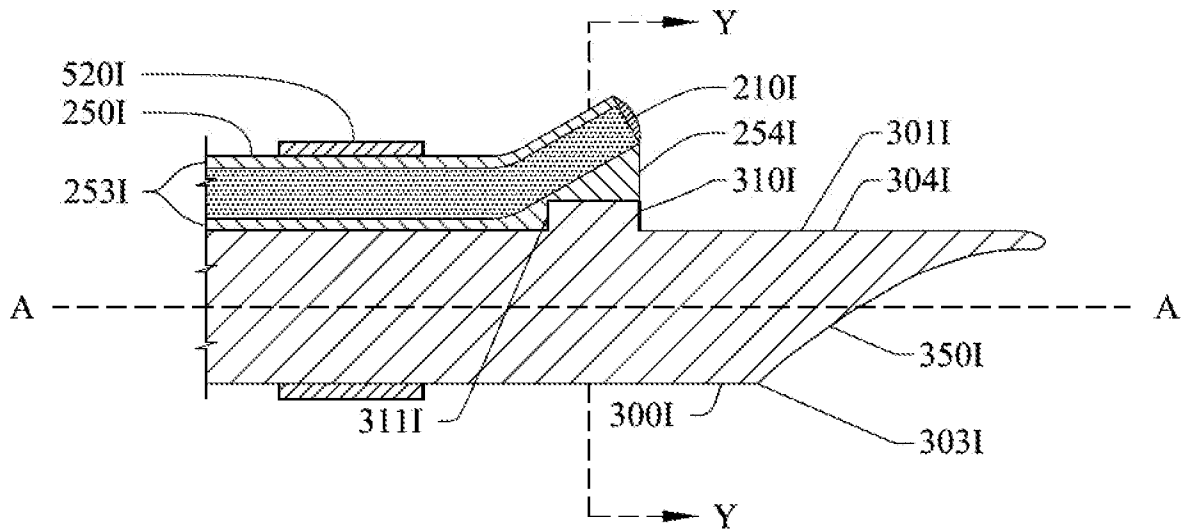

FIGURE 33

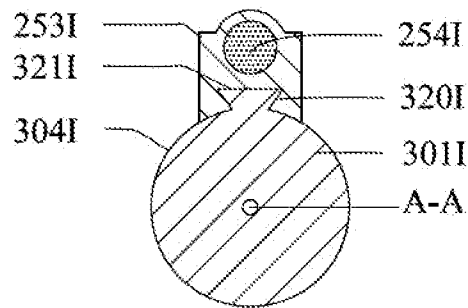

FIGURE 34

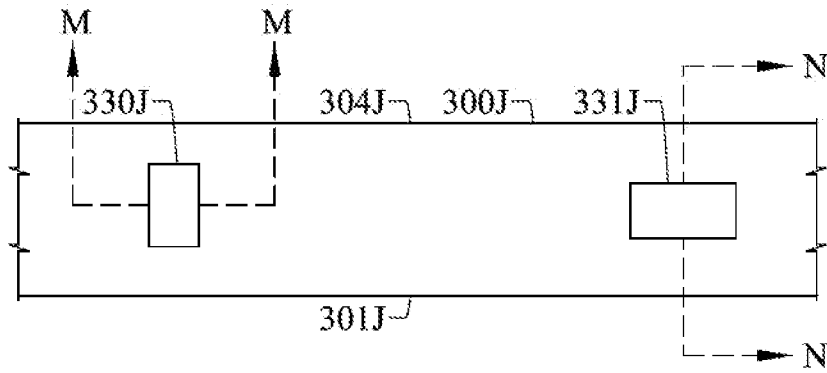

FIGURE 35

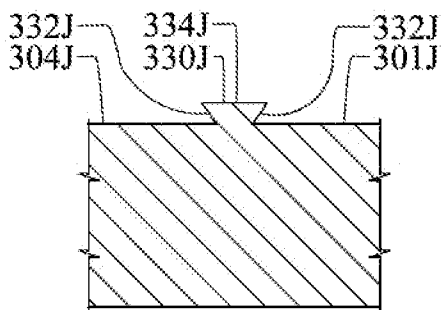

FIGURE 36

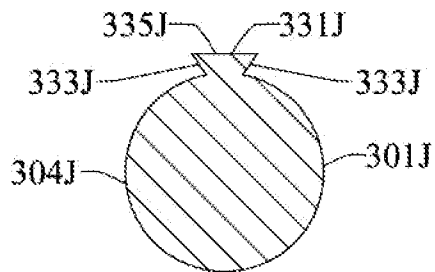

FIGURE 37

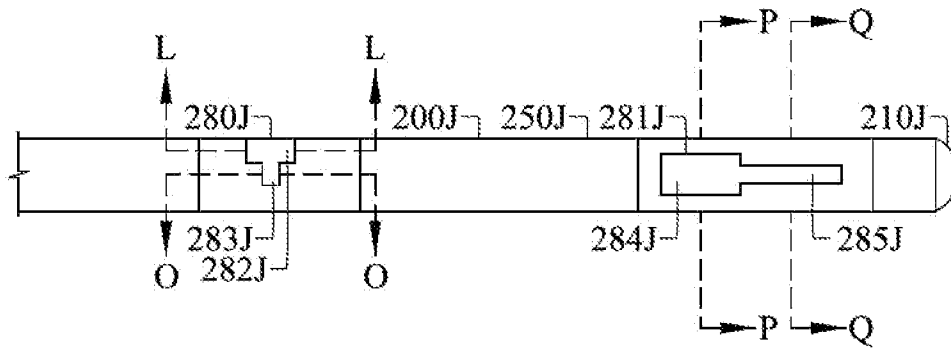

FIGURE 38

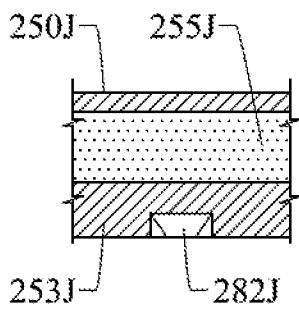

FIGURE 39

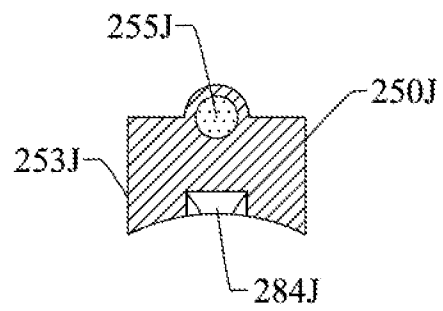

FIGURE 40

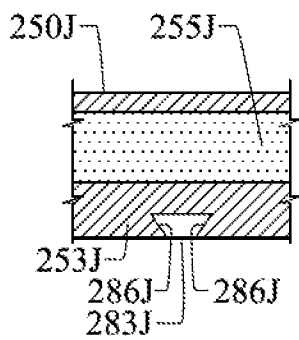

FIGURE 41

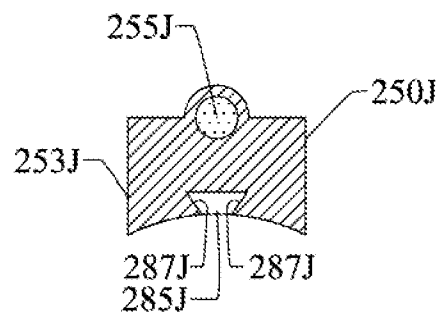

FIGURE 42