

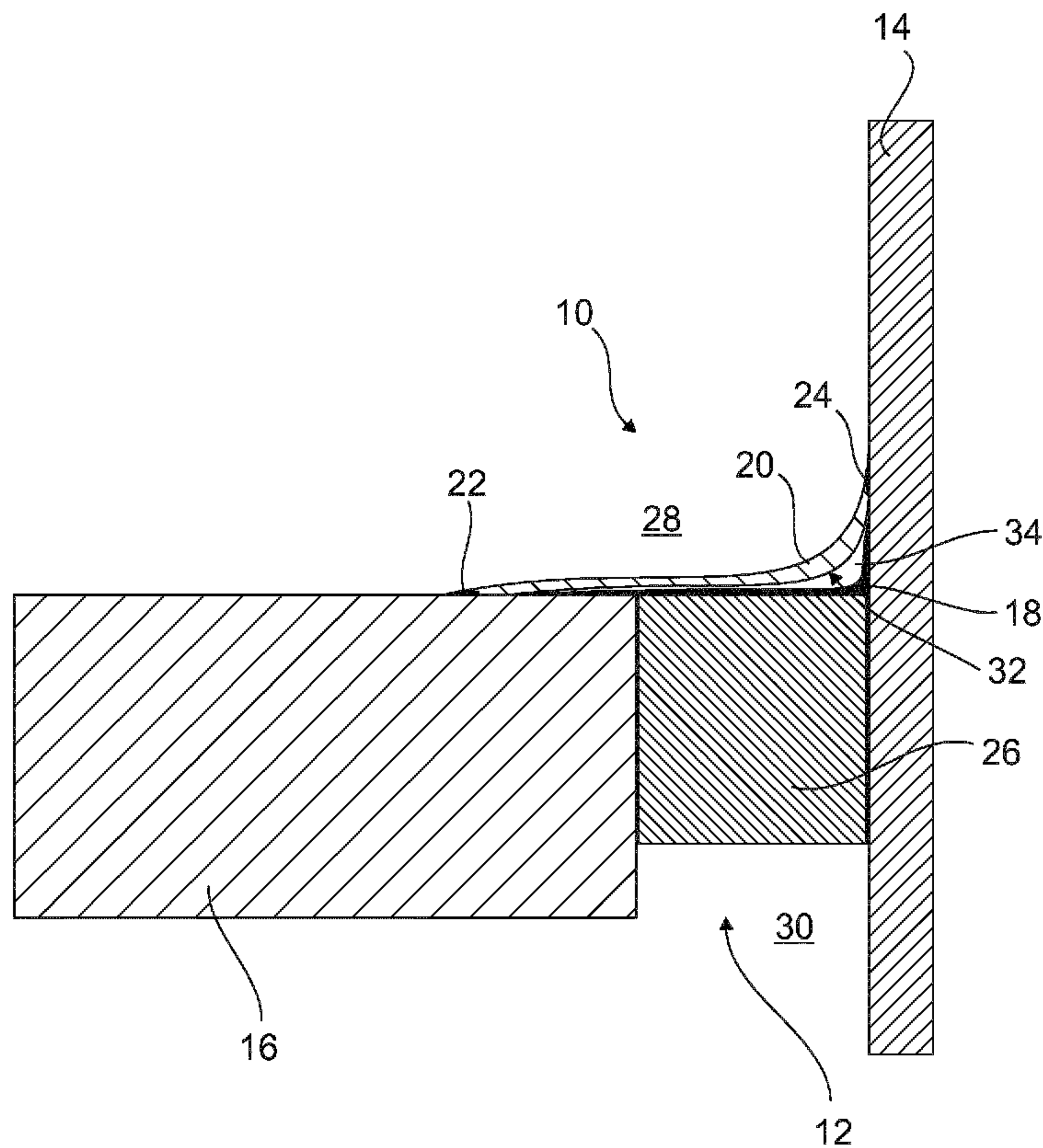

(86) Date de dépôt PCT/PCT Filing Date: 2015/04/08
 (87) Date publication PCT/PCT Publication Date: 2015/10/15
 (85) Entrée phase nationale/National Entry: 2016/09/30
 (86) N° demande PCT/PCT Application No.: EP 2015/057553
 (87) N° publication PCT/PCT Publication No.: 2015/155201
 (30) Priorité/Priority: 2014/04/10 (EP14164156.3)

(51) Cl.Int./Int.Cl. *E04B 1/68* (2006.01)
 (71) Demandeur/Applicant:
 HILTI AKTIENGESELLSCHAFT, LI
 (72) Inventeurs/Inventors:
 SCHULZE, PETER, DE;
 SIMON, SEBASTIAN, DE;
 JULI, STEFAN, AT;
 FORG, CHRISTIAN, DE
 (74) Agent: ROBIC

(54) Titre : PROCEDE PERMETTANT D'ETANCHER ET SYSTEME D'ETANCHEITE
 (54) Title: SEALING METHOD AND SEALING SYSTEM



(57) **Abrégé/Abstract:**

In a method for sealing an interstice (12), in particular a joint between two walls (14, 16), a sealant (18) which is covered with a film (20) upon being applied is used for sealing purposes. A sealing system (10) is also described.

(12) NACH DEM VERTRAG ÜBER DIE INTERNATIONALE ZUSAMMENARBEIT AUF DEM GEBIET DES PATENTWESENS (PCT) VERÖFFENTLICHTE INTERNATIONALE ANMELDUNG

(19) Weltorganisation für geistiges

Eigentum

Internationales Büro

(43) Internationales

Veröffentlichungsdatum

15. Oktober 2015 (15.10.2015)



(10) Internationale Veröffentlichungsnummer

WO 2015/155201 A1

(51) Internationale Patentklassifikation:
E04B 1/68 (2006.01)

(21) Internationales Aktenzeichen: PCT/EP2015/057553

(22) Internationales Anmeldedatum:
8. April 2015 (08.04.2015)

(25) Einreichungssprache: Deutsch

(26) Veröffentlichungssprache: Deutsch

(30) Angaben zur Priorität:
14164156.3 10. April 2014 (10.04.2014) EP(71) Anmelder: HILTI AKTIENGESELLSCHAFT [LI/LI];
Feldkircherstr. 100, CH-9494 Schaan (LI).(72) Erfinder: SCHULZE, Peter; Kornfeldstrasse 6, 86947
Weil (DE). SIMON, Sebastian; Eichendorffweg 12,
86807 Buchloe Lindenberg (DE). JULI, Stefan;
Haldenweg 3, A-6700 Bludenz (AT). FÖRG, Christian;
Gernbergweg 5, 86862 Dillishausen (DE).

(81) Bestimmungsstaaten (soweit nicht anders angegeben, für jede verfügbare nationale Schutzrechtsart): AE, AG, AL, AM, AO, AT, AU, AZ, BA, BB, BG, BH, BN, BR, BW, BY, BZ, CA, CH, CL, CN, CO, CR, CU, CZ, DE, DK, DM, DO, DZ, EC, EE, EG, ES, FI, GB, GD, GE, GH, GM, GT, HN, HR, HU, ID, IL, IN, IR, IS, JP, KE, KG, KN, KP, KR, KZ, LA, LC, LK, LR, LS, LU, LY, MA, MD, ME, MG, MK, MN, MW, MX, MY, MZ, NA, NG, NI, NO, NZ, OM, PA, PE, PG, PH, PL, PT, QA, RO, RS, RU, RW, SA, SC, SD, SE, SG, SK, SL, SM, ST, SV, SY, TH, TJ, TM, TN, TR, TT, TZ, UA, UG, US, UZ, VC, VN, ZA, ZM, ZW.

(84) Bestimmungsstaaten (soweit nicht anders angegeben, für jede verfügbare regionale Schutzrechtsart): ARIPO (BW, GH, GM, KE, LR, LS, MW, MZ, NA, RW, SD, SL, ST, SZ, TZ, UG, ZM, ZW), eurasisches (AM, AZ, BY, KG, KZ, RU, TJ, TM), europäisches (AL, AT, BE, BG, CH, CY, CZ, DE, DK, EE, ES, FI, FR, GB, GR, HR, HU, IE, IS, IT, LT, LU, LV, MC, MK, MT, NL, NO, PL, PT, RO,

[Fortsetzung auf der nächsten Seite]

(54) Title: SEALING METHOD AND SEALING SYSTEM

(54) Bezeichnung : VERFAHREN ZUM ABDICHTEN SOWIE ABDICHTUNGSSYSTEM

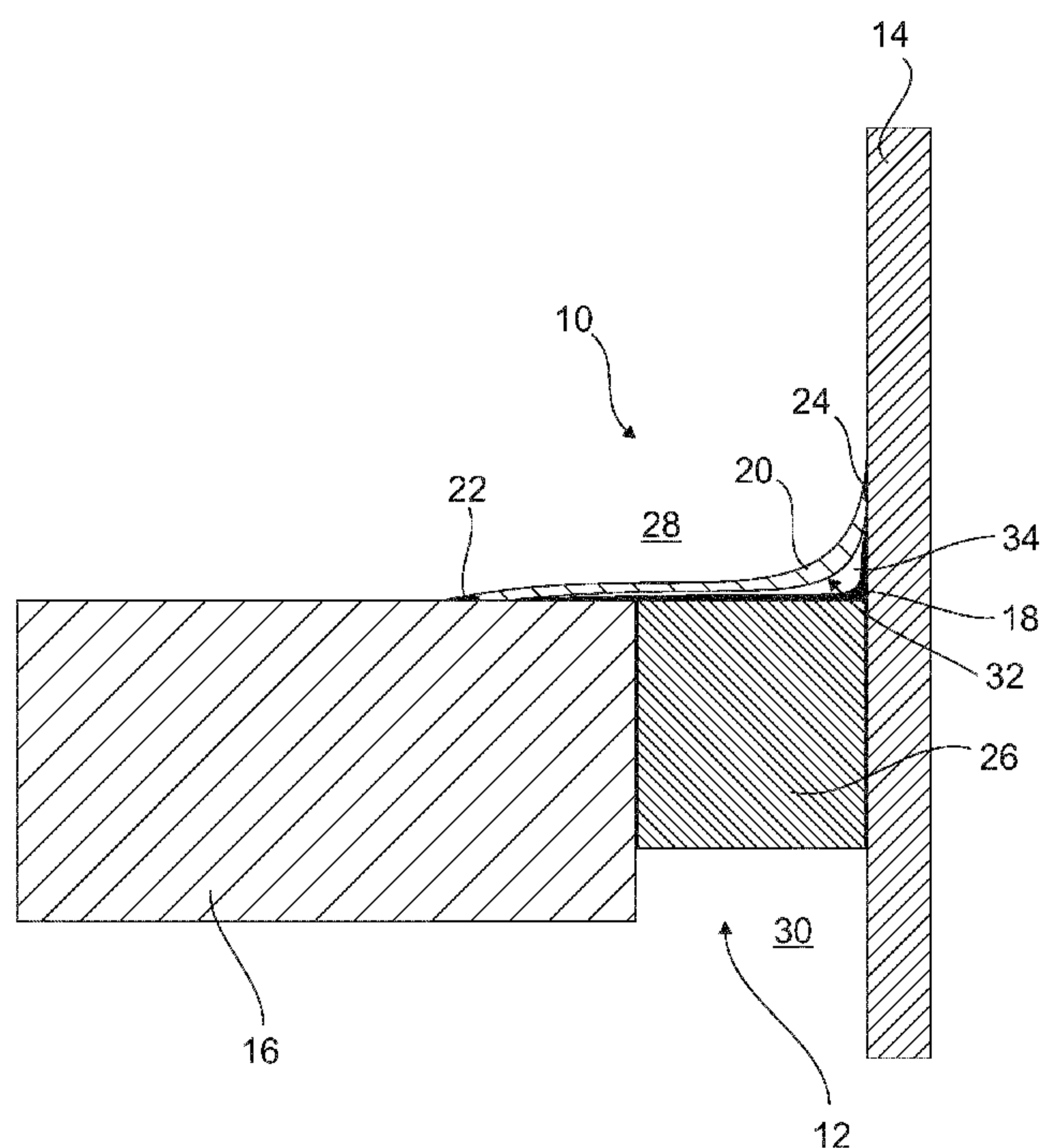

(57) Abstract: In a method for sealing an interstice (12), in particular a joint between two walls (14, 16), a sealant (18) which is covered with a film (20) upon being applied is used for sealing purposes. A sealing system (10) is also described.

(57) Zusammenfassung: Bei einem Verfahren zum Abdichten eines Zwischenraums (12), insbesondere einer Fuge zwischen zwei Wänden (14, 16), ist vorgesehen, dass ein Dichtstoff (18) zur Abdichtung verwendet wird, welcher nach dem Auftragen mit einer Folie (20) abgedeckt wird. Ferner ist ein Abdichtungssystem (10) beschrieben.

WO 2015/155201 A1

WO 2015/155201 A1 

RS, SE, SI, SK, SM, TR), OAPI (BF, BJ, CF, CG, CI, CM, GA, GN, GQ, GW, KM, ML, MR, NE, SN, TD, TG). **Veröffentlicht:** — *mit internationalem Recherchenbericht (Artikel 21 Absatz 3)*

Sealing Method and Sealing System

DESCRIPTION

The invention relates to a method for sealing an interstice as well as a sealing system for sealing an interstice.

Sealing floor joints or joints between walls with a water-based sealant, for example when constructing a building, is known from the prior art. In doing so, the water-based sealants are typically adjusted such that they can be applied in a spraying process. This makes it possible for the sealant to be applied mechanically using a suitable spray device, thereby guaranteeing a rapid as well as an effective application process. Such a method offers the further advantage that the devices that are used can be cleaned with water in a simple manner. Furthermore, this method allows very little material to be used and in addition the water-based sealants are very attractive in term of price as compared to silicone or those based on MS polymers or hybrids.

However, what has turned out to be disadvantageous with this method is that the applied seals can be damaged under certain weather conditions, in particular in rainy weather. The seals are applied at a point in time at which the building envelope is not completely sealed yet. Consequently, rain can penetrate into the building, for example, and is able to wash off or wash away the water-based sealant of the seal that is not completely hardened yet.

Therefore, the object of the invention is to make a method available, which guarantees a functional seal even under adverse weather conditions.

The object is attained according to the invention by a method for sealing an interstice, in particular a joint between two walls such that a sealant which is covered with a film upon being applied is used for sealing purposes. The basic idea of the invention consists of protecting the seal that has not hardened yet by means a covering film thereby guaranteeing that any rain that arises does not wash off or wash away the seal that has not hardened yet.

The sealant used can be a water-based sealant in particular.

Moreover, one aspect of the invention provides that to begin with an insulating material is inserted into the interstice. The insulating material can be a mineral wool in particular. The use of this insulating material improves the insulation between two spaces, which are separated from each other by at least one of the walls. A further aspect of the invention is that the film is affixed, in particular by means of an additional adhesive strip or an additional adhesive point or by an adhesive section configured on the film itself. The fixation of the film ensures that the film cannot be blown away by the wind, which otherwise would result in the applied seal being exposed to the rain.

The sealant is applied in particular by means of a spraying process. The spraying process is an especially efficient method of producing seals, because it can be applied mechanically with simple spray devices. Applicable spray devices can be airless devices for example. Furthermore, the spray devices can be cleaned easily with water if a water-based sealant is being used.

Furthermore, the invention relates to a sealing system for sealing an interstice, consisting of a sealant, in particular a water-based sealant, and a film for covering the applied sealant, in particular a water-tight, diffusion-enabling film. This sealing system, which can be used for one of the previously mentioned methods, guarantees that the applied sealant is protected for one from outside weather conditions and secondly is able to harden, because the film for covering the applied sealant is diffusion-enabling. This means that the drying time of the applied sealant is only negligibly extended as compared to the drying time of a sealant applied without a covering film. In addition, a protection against rain weather is guaranteed. The water-tight and diffusion-enabling film is configured in the process such that it is equivalent to a membrane.

One aspect of the invention provides that the film have a structuring, in particular a flocking. The structuring of the film produces a property that promotes drying of the sealant, because the structuring achieves a capillary effect, which absorbs moisture from the sealant so that it dries more rapidly.

A further aspect of the invention is that the film is constructed of a plurality of layers, in particular of at least one layer of fleece and one layer of a vapor-diffusion-enabling functional membrane. This combination provides an especially suitable film, which is water-tight for one and also diffusion-enabling or "breathable" so that the applied seal is protected from rain and at the same time hardens rapidly. Such a film is known for example from the field of outdoor apparel.

The invention further provides that the film is elastic, in particular that the hardened sealant and the film have similar elastic properties. Because of the fixation of the film, the film should be designed to be preferably elastic so that it can yield to stress or is able to follow the movements of the interstice. The fact that the film and the hardened seal have similar properties moreover guarantees that no stress can arise between the film and the seal.

It is provided in particular that the sealant is a water-based polymer dispersion. Examples of aqueous polymer dispersions which have notably been proven are aqueous acrylate dispersions, aqueous dispersions or emulsions of urea resin, formaldehyde resin or melamine resin, polyvinyl acetates, polyvinyl alcohols, acrylonitrile, styrene acrylics, polyurethanes and copolymers thereof, of which an acrylate dispersion is an especially favorable water-based sealant material.

It is further provided that the sealant consists of a fire protection joint spray and the film for instance of a window sealing tape, wherein the window sealing tape is a membrane in particular, such as a vapor-diffusion-enabling or vapor-diffusion-sealed polyester/polypropylene/polyester combination or a polyamide film with PET spun-bonded fabric having an adhesive strip applied to one side. These two materials constitute an especially preferred combination, because the material properties thereof are coordinated with each other so that an especially good drying as well as a protective effect of the sealant can be guaranteed.

The film consists in particular of hardened sealant so that it is ensured that the elastic properties of the film and of the sealant are the same, thereby guaranteeing that stress between the film and the sealant is prevented.

Additional advantages and features of the invention are yielded from the following description as well as the following drawing to which reference is made. The single figure shows a schematic arrangement of a sealing system according to the invention.

The single figure shows a sealing system 10 according to the invention, which is used for sealing an interstice 12. The interstice 12 is configured between a first wall 14 and a second wall 16, which are designed as a wall 14 and as a floor 16. Therefore, the interstice 12 is a floor joint.

The sealing system 10 consists of a sealant 18, which is applied such that the interstice 12 is sealed tight at least on one side. Furthermore, the sealing system 10 has a film 20, which is fastened by means of a first adhesive section 22 to the floor 16 as well as by means of a second adhesive section 24 to the wall 14. The second adhesive section 24 prevents the film

20 from washing away from the water running down the wall 14. The adhesive section 22 can alternatively be omitted without impairing the impermeability achieved by the film 20. The adhesive sections 22, 24 are configured on the film 20. The film 20 is thereby stretched over the applied sealant 18 so that the sealant 18 is protected. As the figure shows, the film 20 does not touch the sealant 18 in the process. Alternatively, the film 20 can also be placed on the still moist sealant 18 so that the film 20 partially touches the sealant 18 (not shown); this does not have any negative effects on the subsequent functionality of the sealant 18, however.

The sealing system 10 can furthermore have an insulating material 26, which is inserted into the interstice 12 in order to improve the insulation between a first space 28 and a second space 30, which are separated from each other by the wall 16.

The sealant 18 is produced thereby to be water-based so that the sealant 18 can be easily applied mechanically in a spraying process. However, the sealant 18 must dry to harden, which is why the film 20 is at least diffusion-enabling.

Water vapor that is separated from the sealant 18 in the drying process can exit through the film 20 and escape into the first space 28. The film 20 can be provided thereby in different embodiments, which produce a more rapid drying of the sealant 18. For example, this can be guaranteed by a flocking or another structuring 32 of the side of the film 20 associated with the sealant 18. Moisture thereby escapes from the sealant 18 more rapidly due to the surface tension of the sprayed-on fluid sealant 18 as well as the surface tension of the structuring 32 of the film 20.

Furthermore, the film 20 serves to protect the water-based sealant 18 from rain for example, so that the sealant 18 does not get washed off or washed away if it rains. For this purpose, the film 20 is at least water-repellant from the side facing away from the sealant 18.

The sealing system 10 is thereby used in the following manner:

When constructing a building, for example a high-rise building, the joints between two walls 14, 16 are sealed at a relatively early point in time at which the building is still not sealed and it is therefore possible for rain water to get into the building.

The sealant 18 is applied by means of spraying process, wherein the sealant 18 is applied to the floor 16, the wall 14 and the insulating material 26 in order to guarantee a functional sealing of an interstice 12.

Because water-based sealants 18 are used for sealing, it must now be ensured in the case of an impending change in weather that the applied sealant 18 that has not hardened yet does not get washed off or washed away by rain water. To this end, it is necessary for at least the sealant 18 on the highest floor be protected by the film 20.

For this purpose, the film 20 is water-repellant so that the rain water is not able to penetrate through the film 20 from outside. In addition, the film 20 is diffusion-enabling so that the sealant 18 that still needs to dry can dry without moisture accumulating within the space 34 spanned by the film 20 between the film 20 and the sealant 18.

The film 20 is thereby fastened by means of the two adhesive sections 22, 24 to the wall 14 or to the floor 16 in order to also keep the film 20 from being blown away by strong winds.

Instead of the adhesive sections 22, 24 configured on the film 20, the film 20 can also be fastened to the wall 14 and to the floor 16 by means of adhesive points, wherein the adhesive points can be applied spray dots of the sealant 18. Alternatively, the film 20 can also be fastened to the wall 14 and to the floor 16 with additional adhesive strips. Furthermore, it is possible to also place the film 20 on the still moist sealant 18, making it possible to thereby dispense with the additional spray dots or the additional adhesive strips.

Because it is possible for adhesions to form between the film 20 and the sealant 18 when the film 20 is being applied to the sealant 18 that has not yet hardened, the film 20 preferably has similar elastic properties as the sealant 18, thereby guaranteeing that the film 20 and the sealant 18 form a stress-free system. This ensures that the film 20 and the sealant 18 are able to "function" or change without the protective function of the film 20 being hindered.

Moreover, it is advantageous that the film 20 and the sealant 18 have elastic properties if interstices 12 are irregular or move around.

These types of usable films 20 are typically known from the roof area for sealing the insulation. They also have applications in the field of outdoor apparel.

The method according to the invention makes a sealing method available, which combines all previous advantages and can also be used even under unfavorable weather conditions. The drying time for the applied sealant 18 is extended only negligibly because of the film 20, wherein the film 20 is also only stretched over the sealant 18 being hardened when rain is anticipated.

However, it is advantageous over the method known from the prior art that the method according to the invention can also be used in unfavorable weather conditions, wherein it is

no longer necessary to resort to other more expensive sealants. Additional costs or an additional expense are incurred with the method according to the invention merely in cases in which adverse weather is being anticipated. However, this is disproportionate to the costs that are otherwise incurred when a more expensive sealant is used.

Therefore, the method according to the invention constitutes a further development of the method known until now from the prior art, because, in contrast to the previous method, said method can also be used during unfavorable weather conditions.

PATENT CLAIMS

1. Method for sealing an interstice (12), in particular a joint between two walls (14, 16), wherein a sealant (18) which is covered with a film (20) upon being applied is used for sealing purposes.
2. Method according to Claim 1, characterized in that first of all an insulating material (26) is inserted into the interstice (12), in particular mineral wool.
3. Method according to Claim 1 or 2, characterized in that the film (20) is affixed, in particular by means of an additional adhesive strip or an additional adhesive point or by an adhesive section (22, 24) configured on the film itself.
4. Method according to one of the preceding claims, characterized in that the sealant (18) is applied by means of a spraying process.
5. Sealing system (10) for sealing an interstice (12), consisting of a sealant (18), in particular a water-based sealant, and a film (20) for covering the applied sealant (18), in particular a water-tight, diffusion-enabling film.
6. Sealing system (10) according to Claim 5, characterized in that the film (20) has a structuring (32), in particular a flocking.
7. Sealing system (10) according to Claim 5 or 6, characterized in that the film (20) is constructed of a plurality of layers, in particular of at least one fleece layer and one layer of a vapor-diffusion-enabling functional membrane.
8. Sealing system (10) according to one of Claims 5 to 7, characterized in that the film (20) is elastic, in particular that the hardened sealant (18) and the film (20) have similar elastic properties.
9. Sealing system (10) according to one of Claims 5 to 8, characterized in that the sealant (18) is an acrylate dispersion.
10. Sealing system (10) according to one of Claims 5 to 9, characterized in that the sealant (18) consists of a fire protection joint spray and the film (20) consists of a membrane.

11. Sealing system (10) according to one of Claims 5 to 9, characterized in that the film (20) consists of a hardened sealant (18).

1 / 1

