



(19) **United States**
(12) **Patent Application Publication**
Kates

(10) **Pub. No.: US 2008/0223300 A1**
(43) **Pub. Date: Sep. 18, 2008**

(54) **SYSTEM AND METHOD FOR
COMPUTER-CONTROLLED PET WATER
DISPENSER**

Publication Classification

(51) **Int. Cl.**
A01K 39/02 (2006.01)
(52) **U.S. Cl.** 119/72

(76) **Inventor: Lawrence Kates, Corona Del Mar,
CA (US)**

Correspondence Address:
**KNOBBE MARTENS OLSON & BEAR LLP
2040 MAIN STREET, FOURTEENTH FLOOR
IRVINE, CA 92614 (US)**

(21) **Appl. No.: 12/131,767**

(22) **Filed: Jun. 2, 2008**

Related U.S. Application Data

(62) Division of application No. 11/417,394, filed on May 3, 2006, now Pat. No. 7,380,518, which is a division of application No. 10/893,549, filed on Jul. 15, 2004.

(57) **ABSTRACT**

A computer-aided training and management system that uses a computer or other processor in wireless communication with an instrumented dog collar and/or optionally, one or more dog interaction devices, such as, for example, video monitors, loudspeakers, video cameras, training toys (e.g., ball, bone, moving toy, etc.), an animatronics "trainer," a treat dispenser, a food dispensing and monitoring device, a water dispensing and monitoring device, tracking devices, a dog door, dog-monitoring doghouse, a dog-monitoring dog toilet, is described. In one embodiment, the instrumented dog collar is in two-way communication with a central computer system.

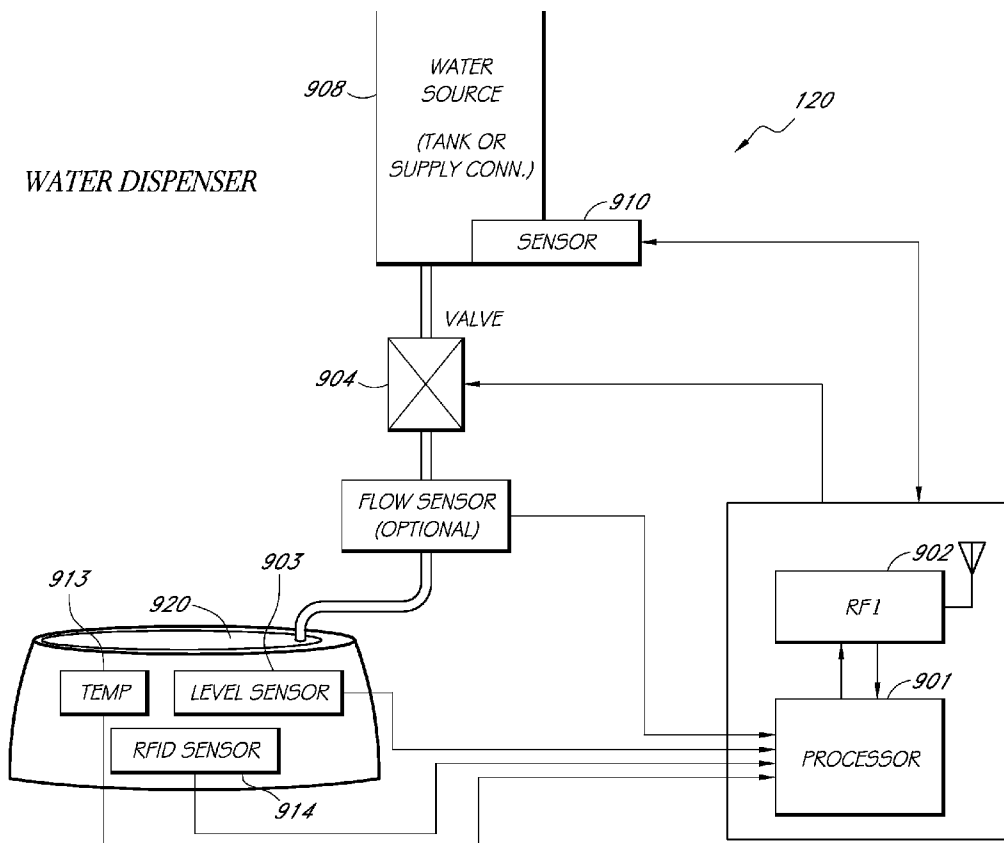

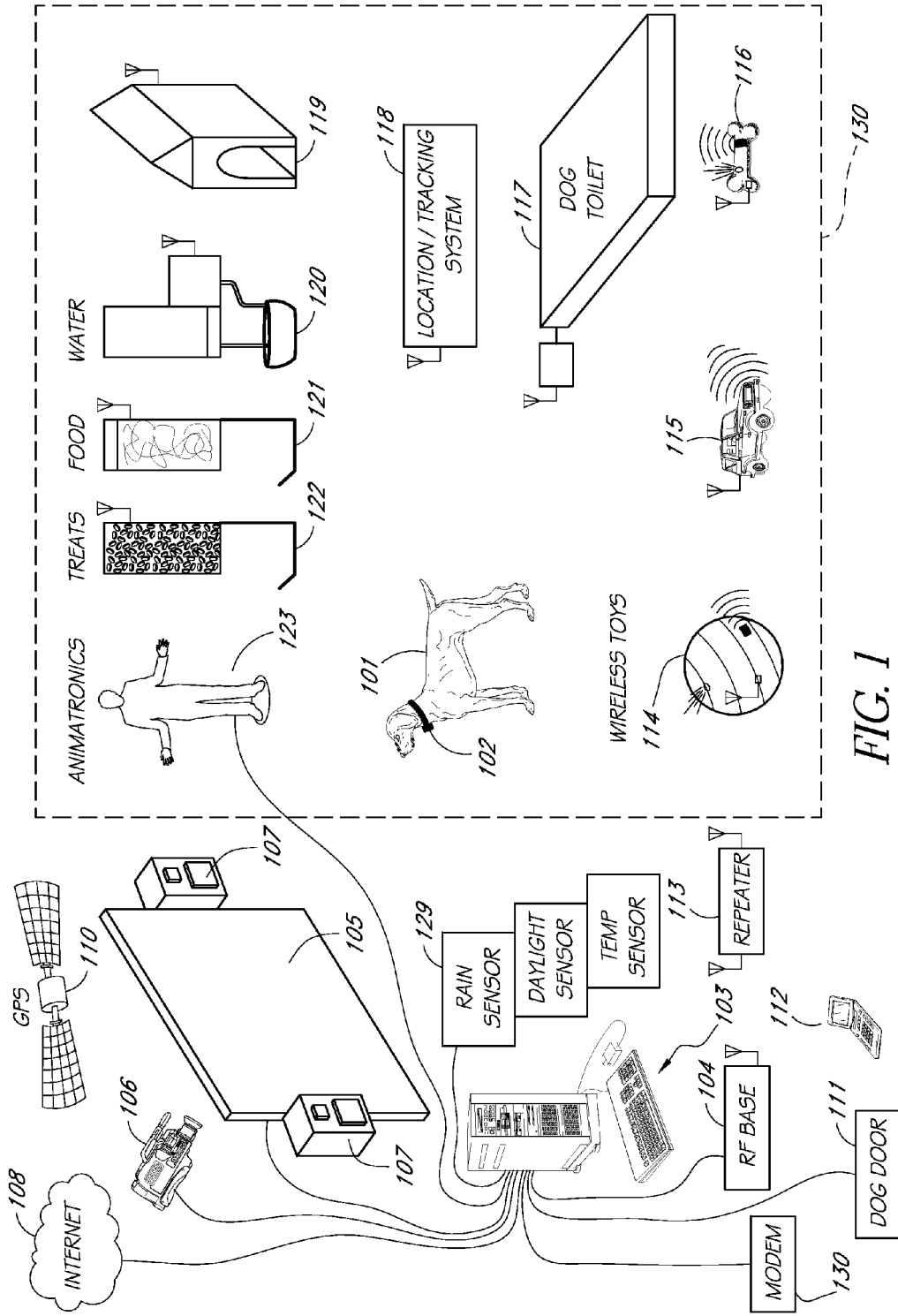

FIG. 1

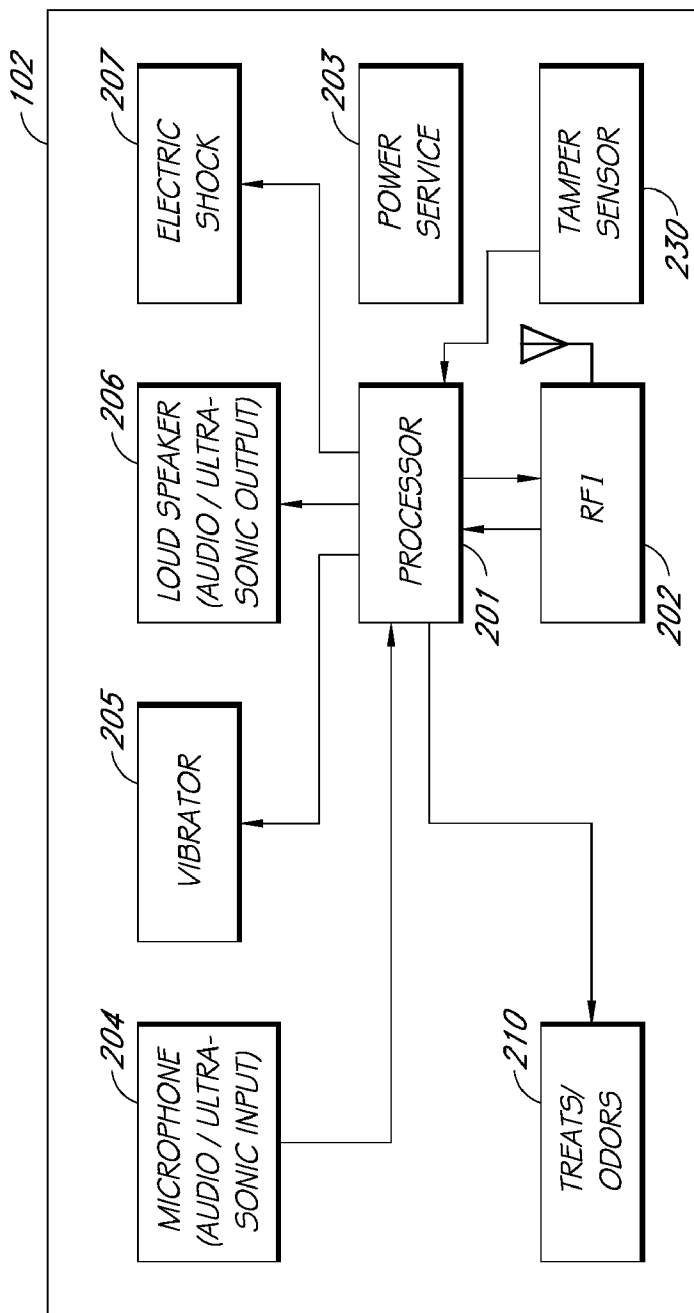
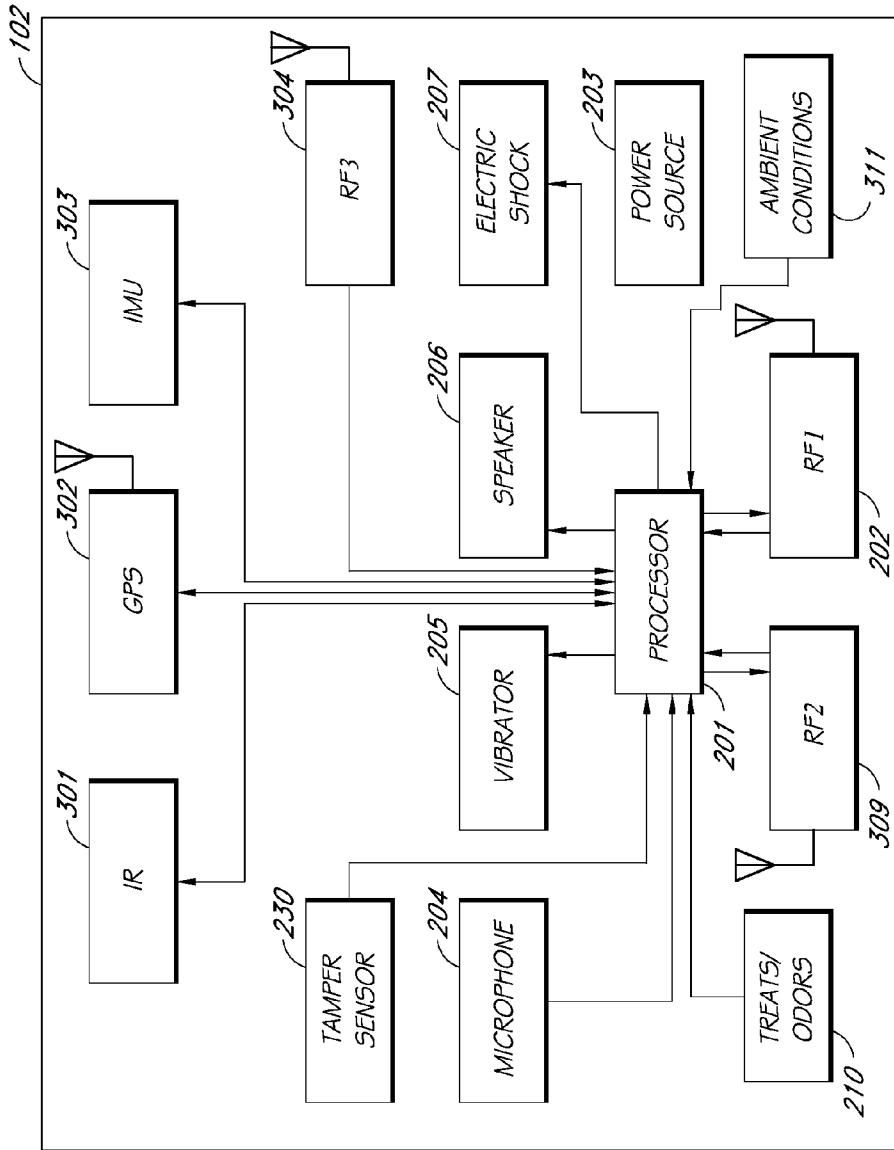

FIG. 2

DOG COLLAR I (TRAINING)



ID	TEMP	PULSE
RFID TAG		

FIG. 3

DOG COLLAR II (TRAINING AND MANAGEMENT)

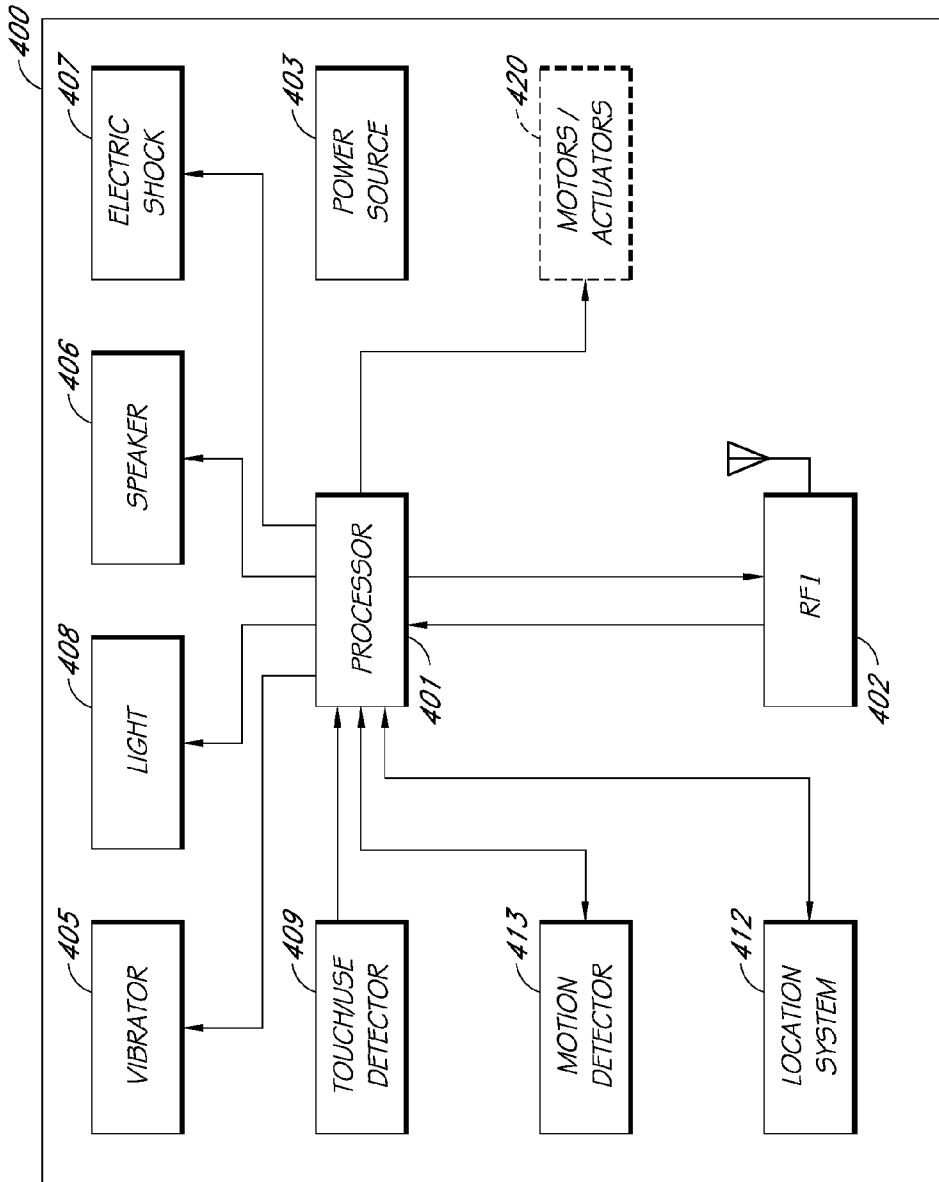

FIG. 4
DOG TOY

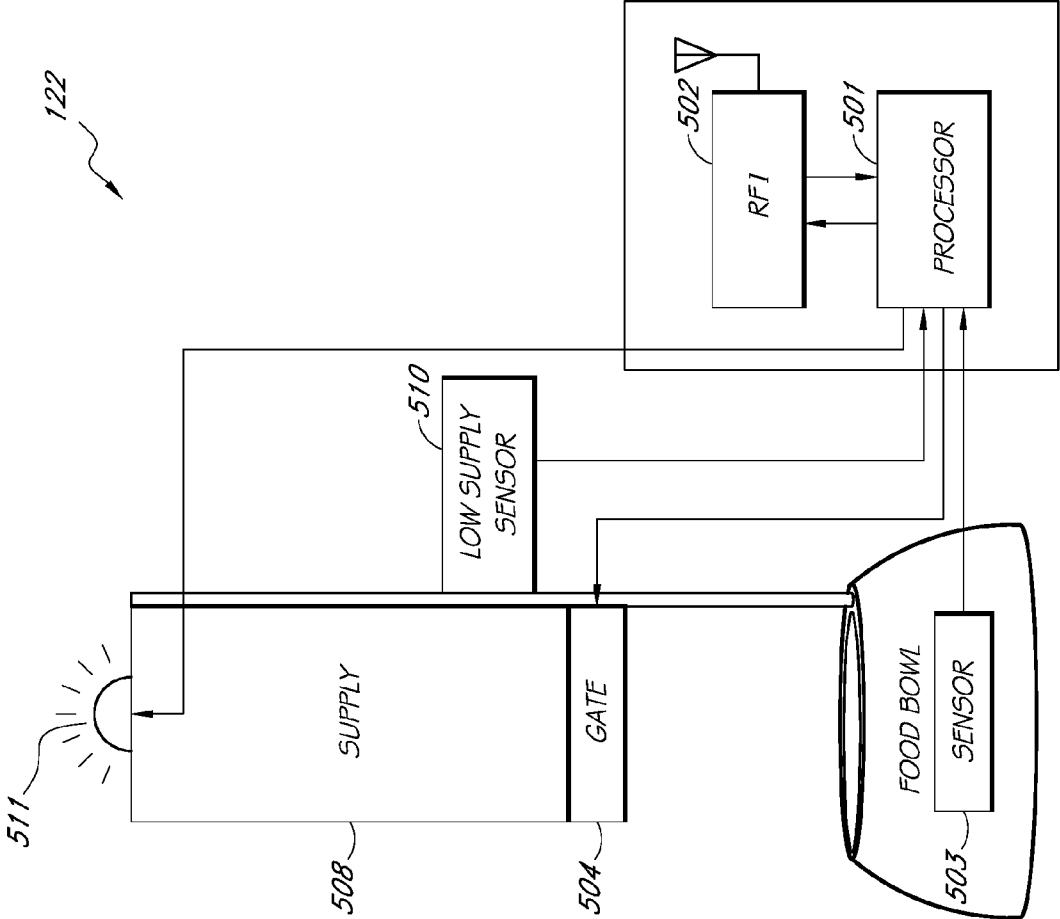

FIG. 5
TREAT DISPENSER

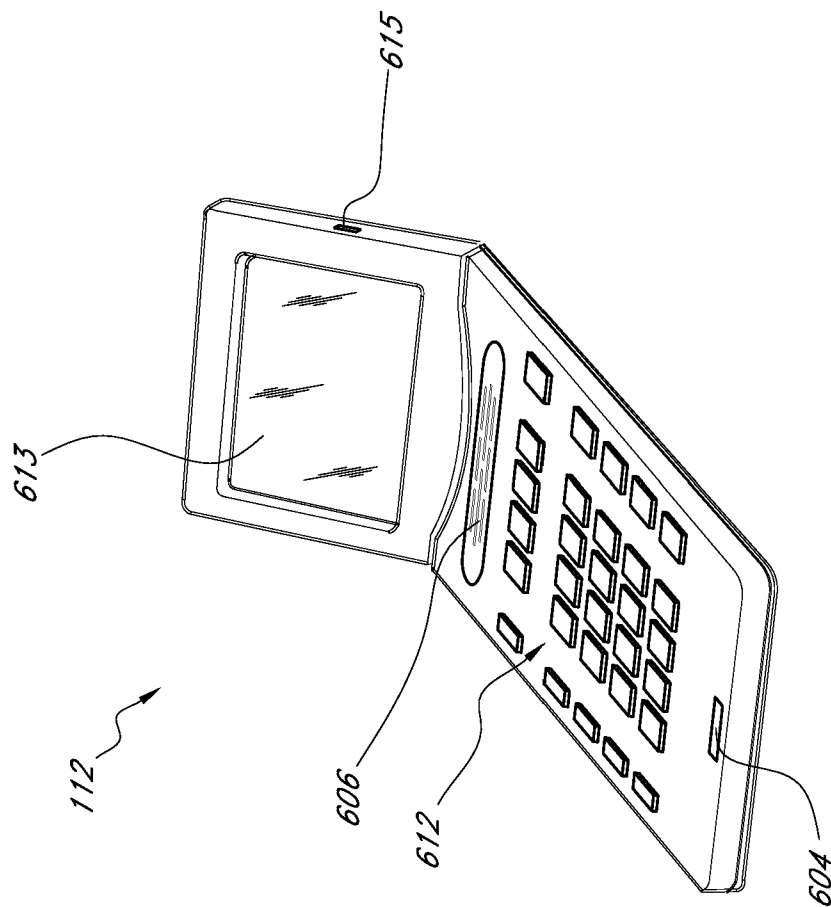

FIG. 6A

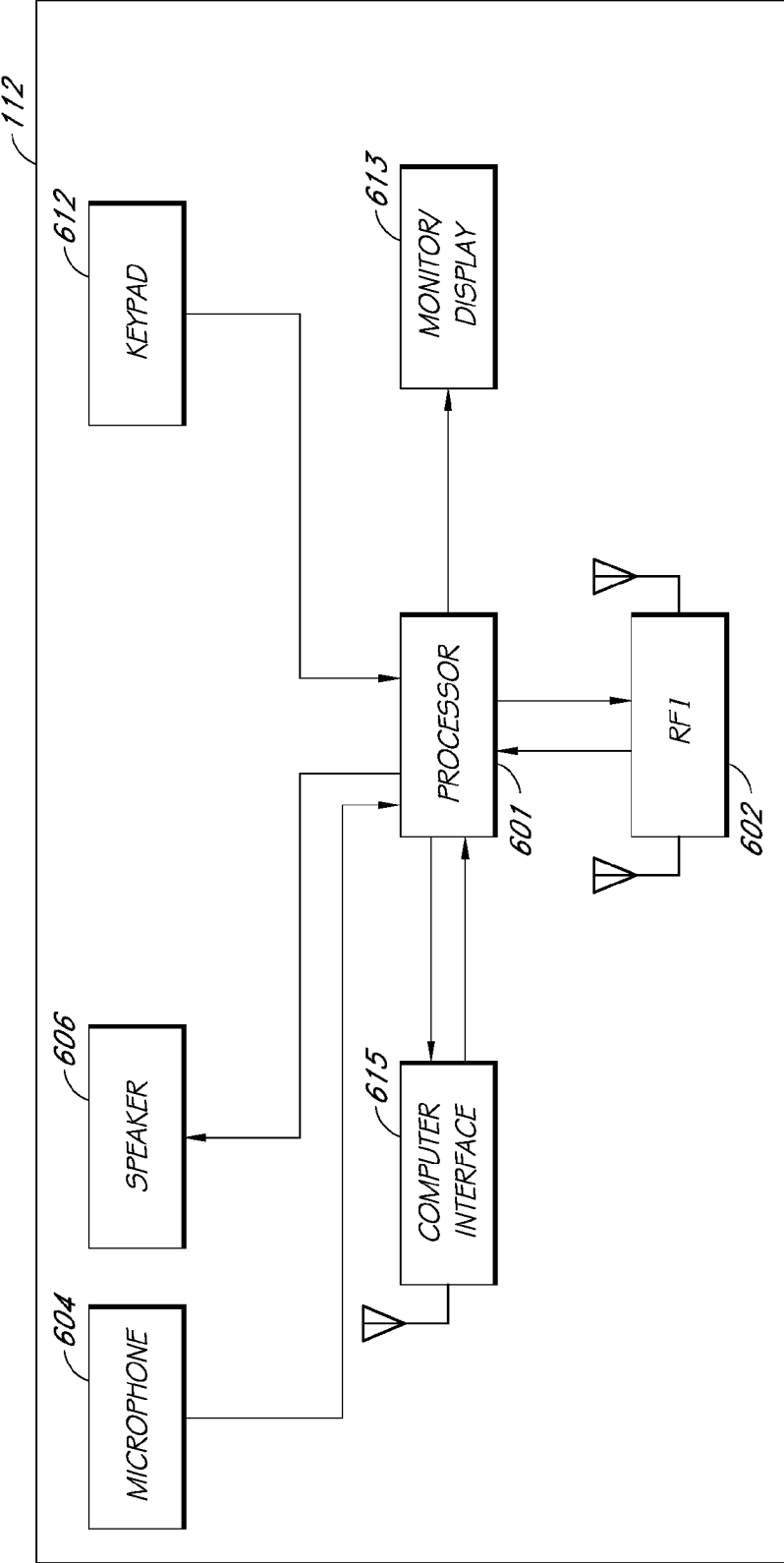
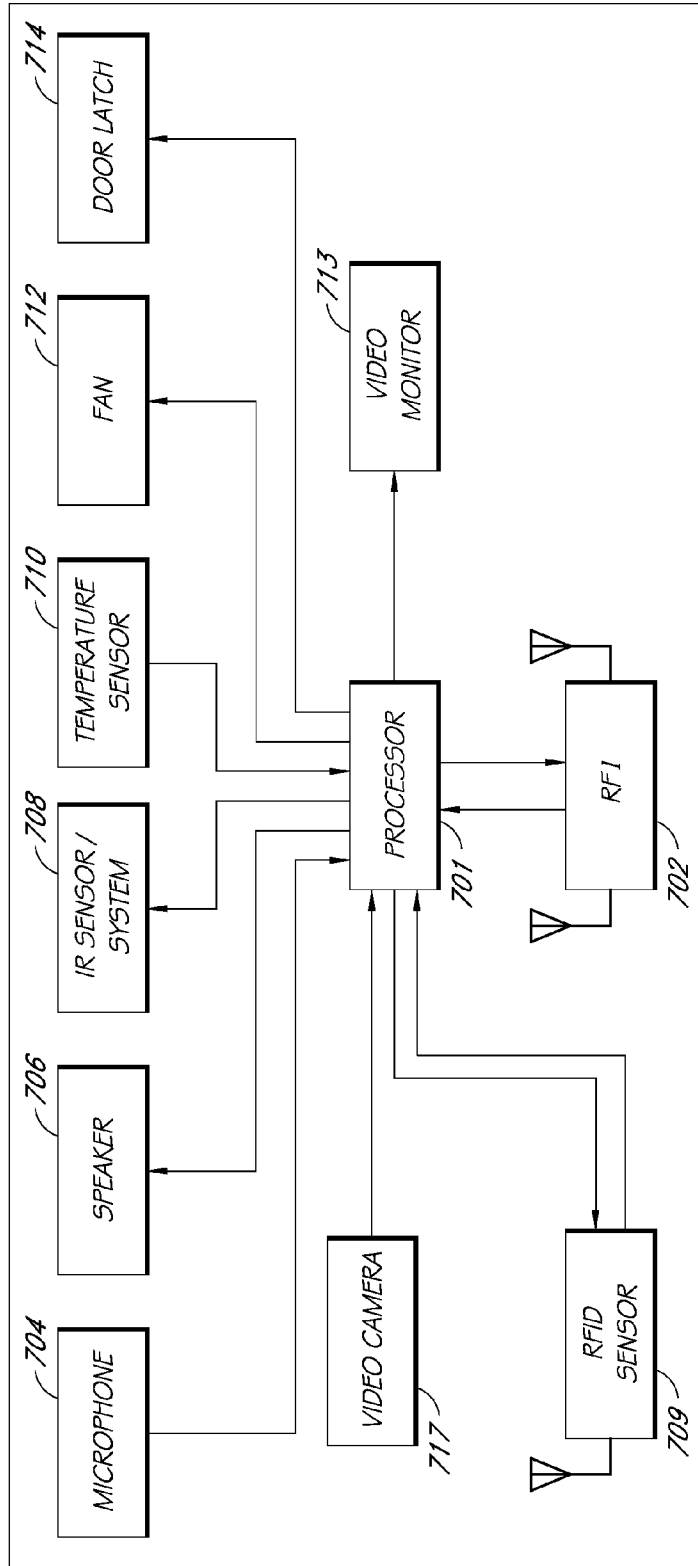

FIG. 6B

FIG. 7



121

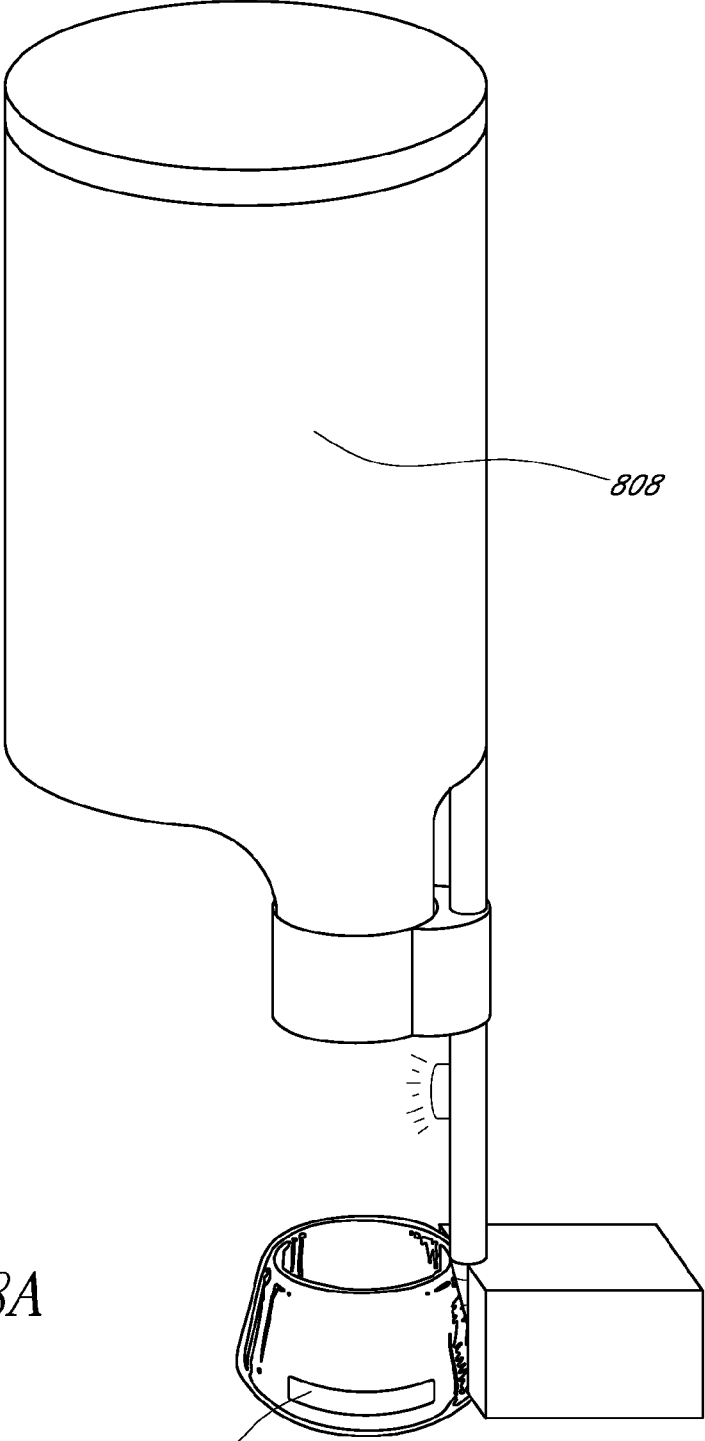

FIG. 8A

803

808

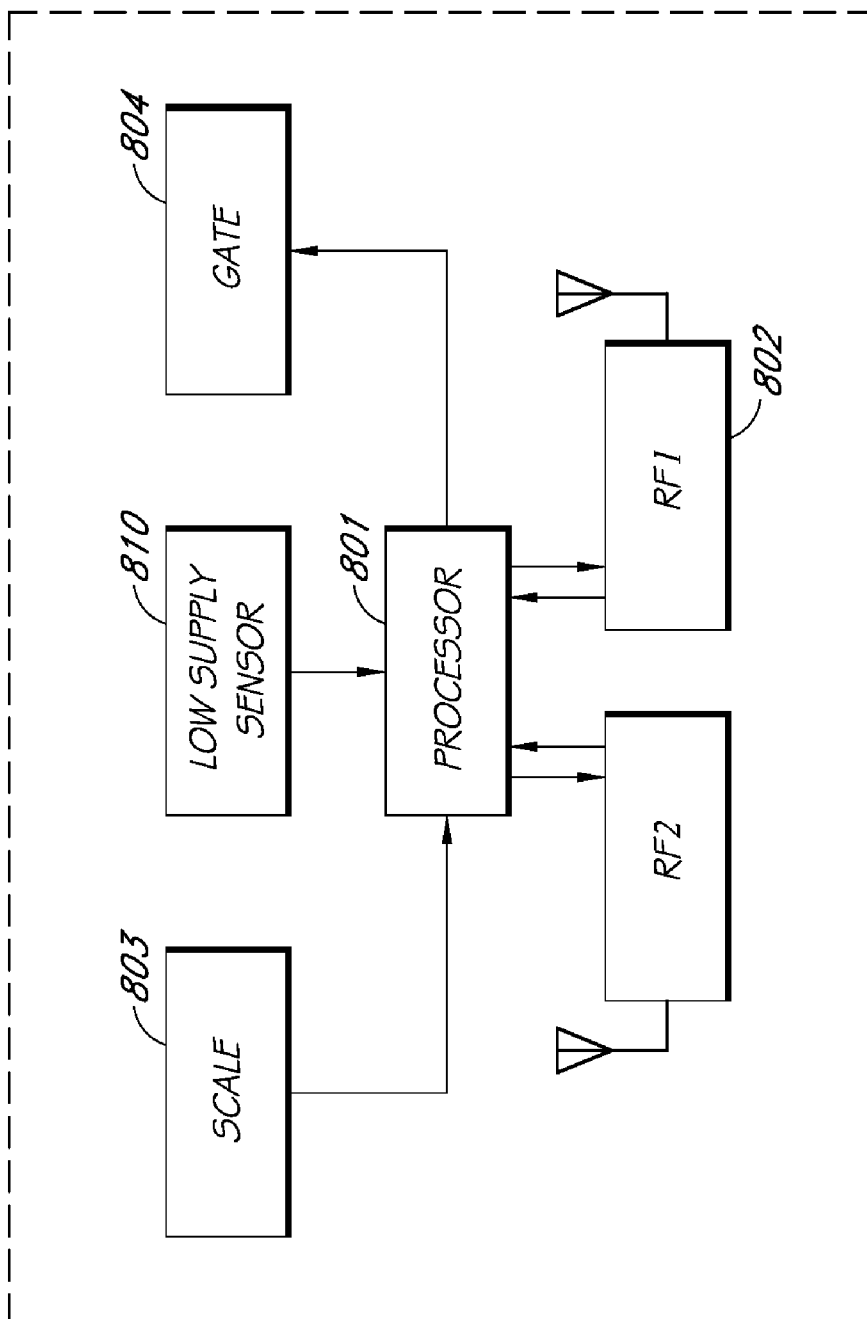

FIG. 8B

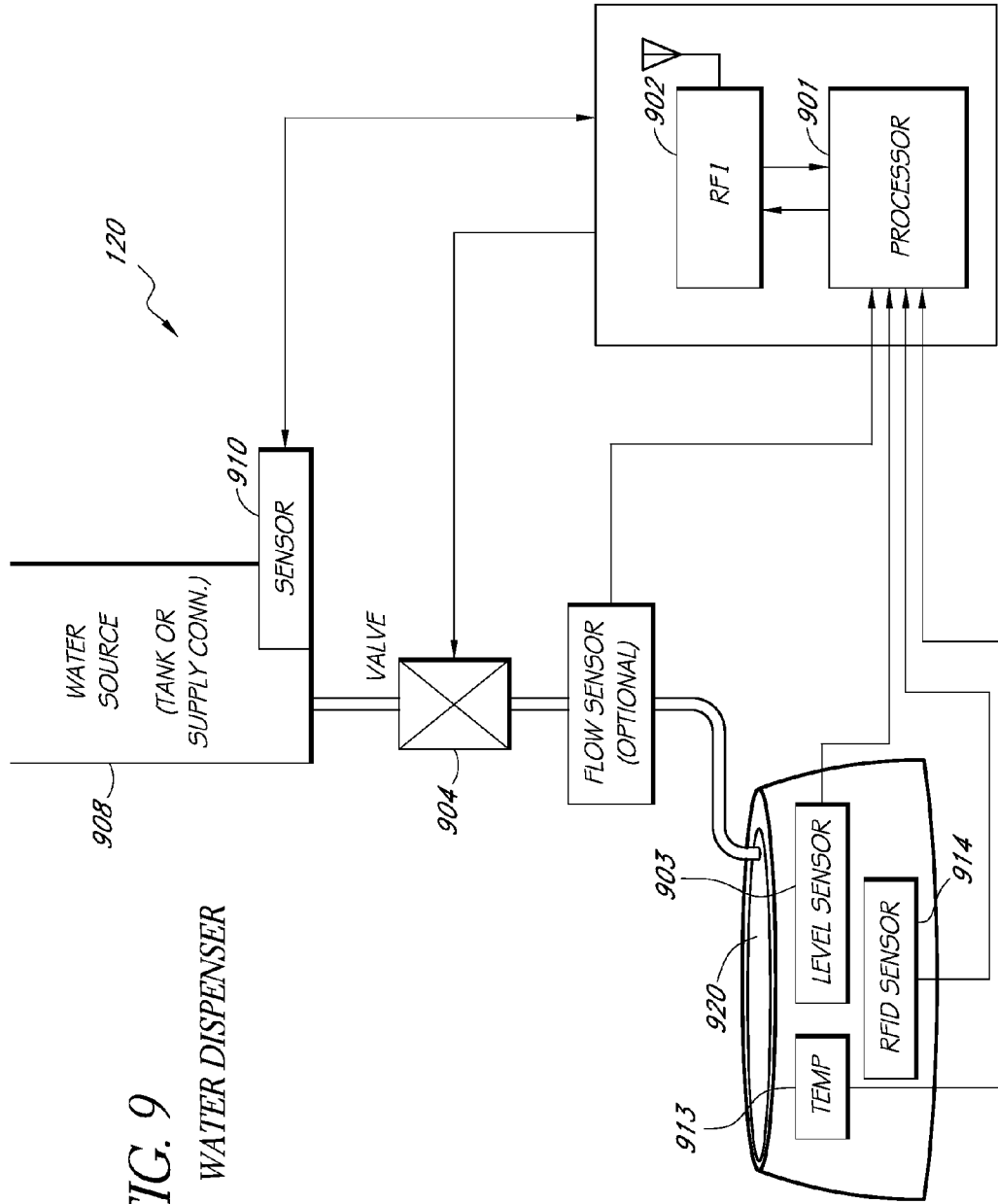

FIG. 9
WATER DISPENSER

FIG. 10
DOG TOILET

117 ↗

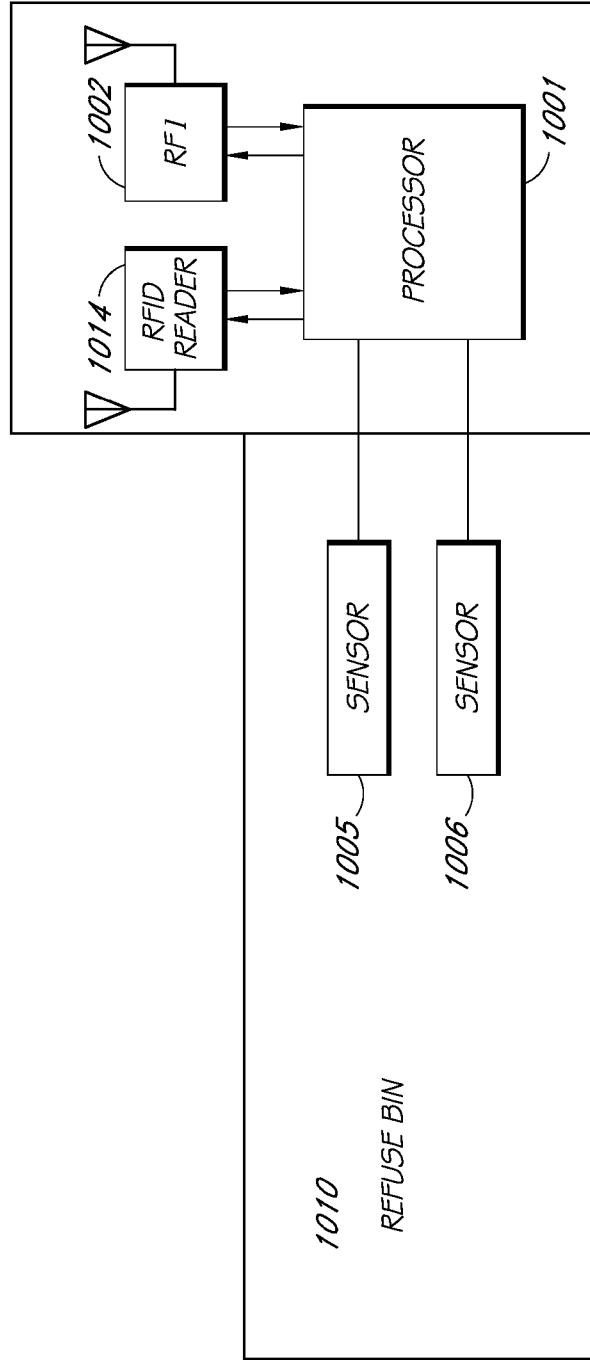
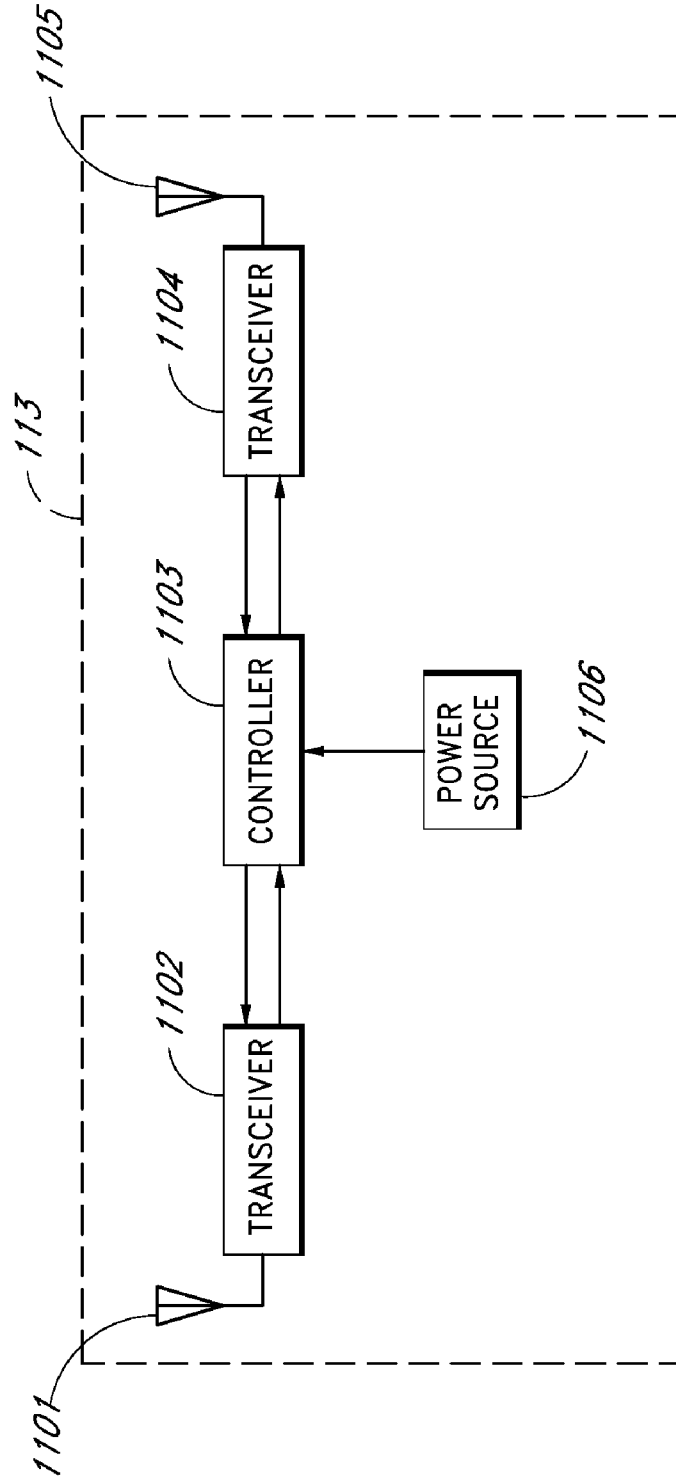

FIG. 11



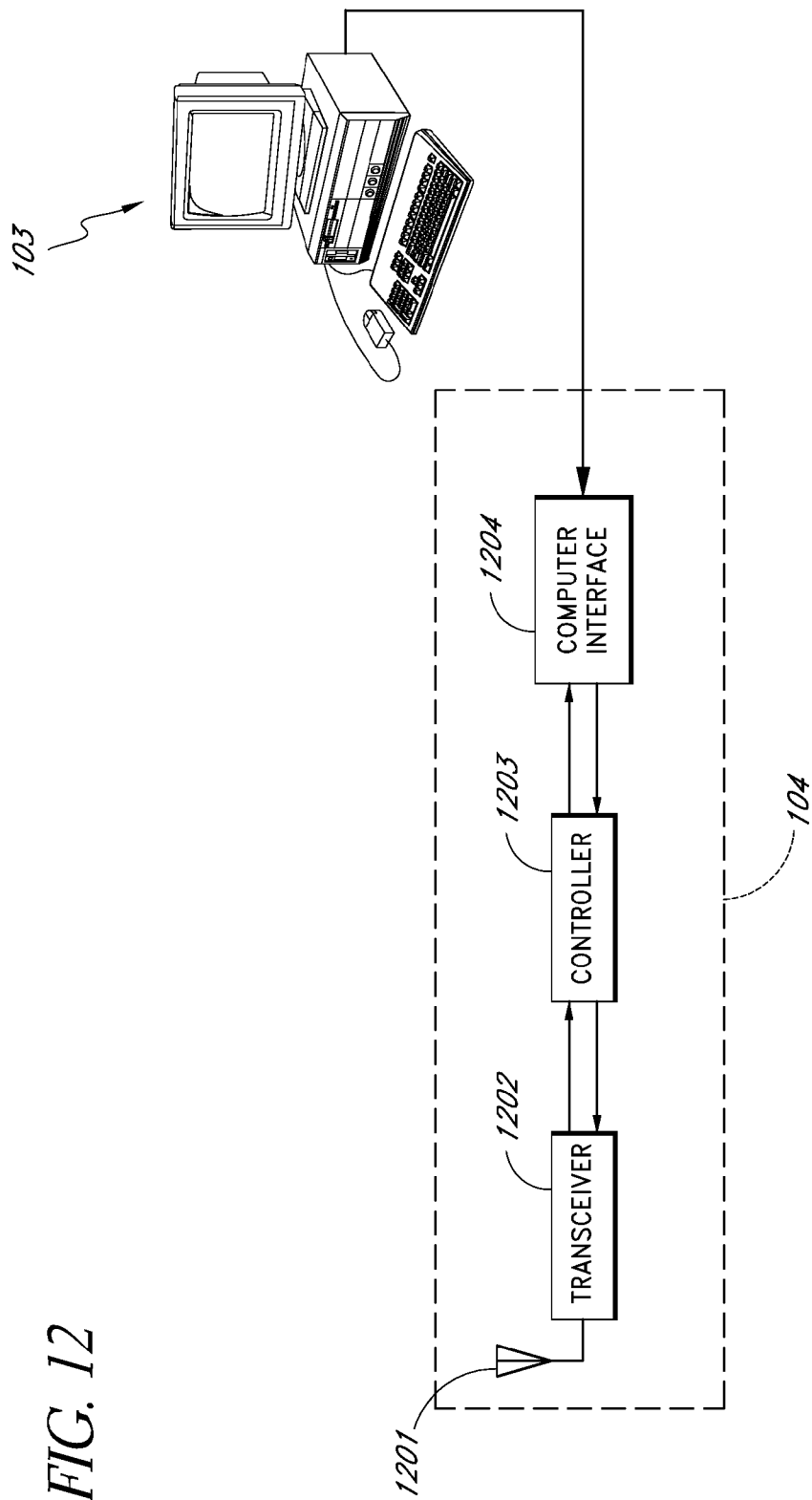
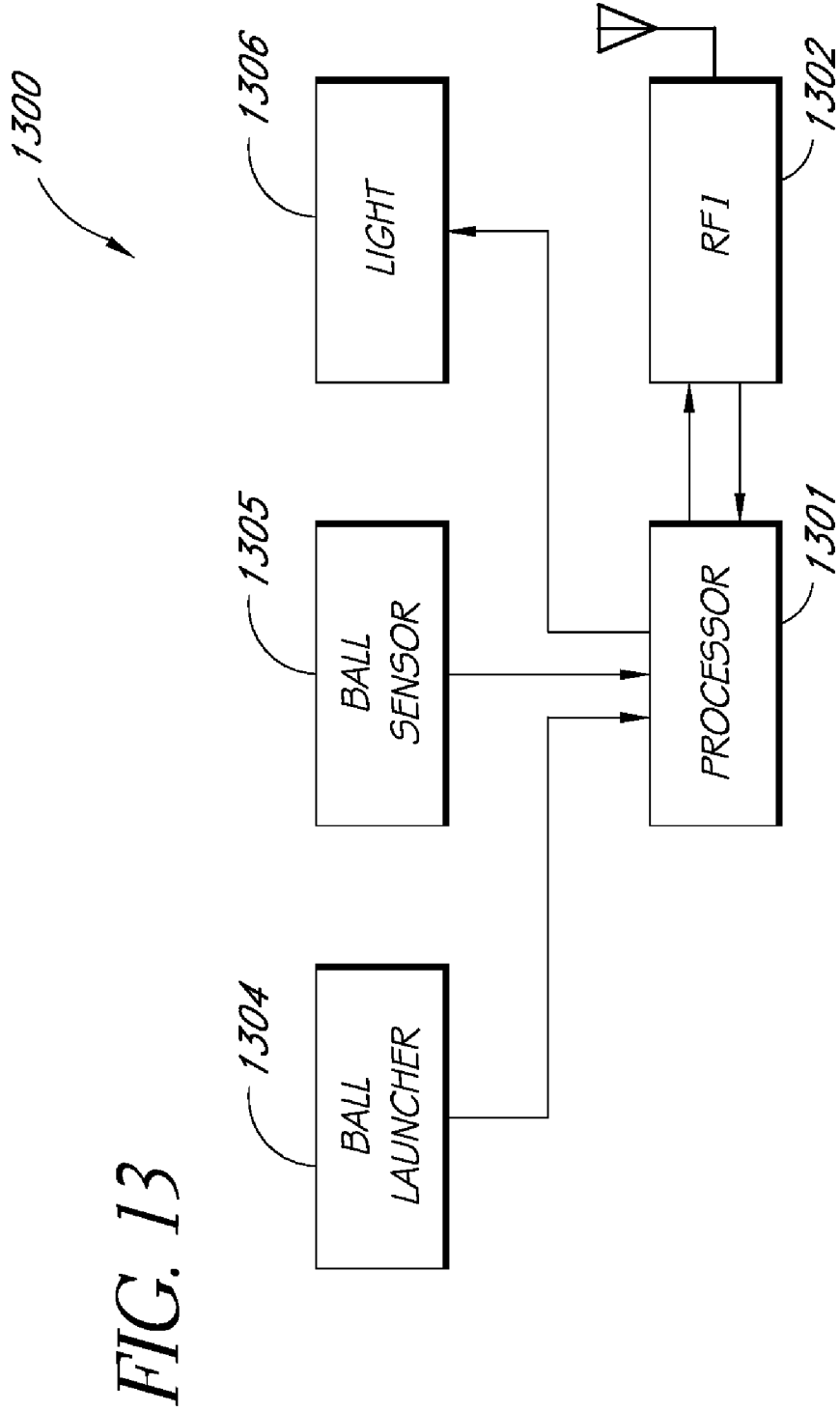

FIG. 12



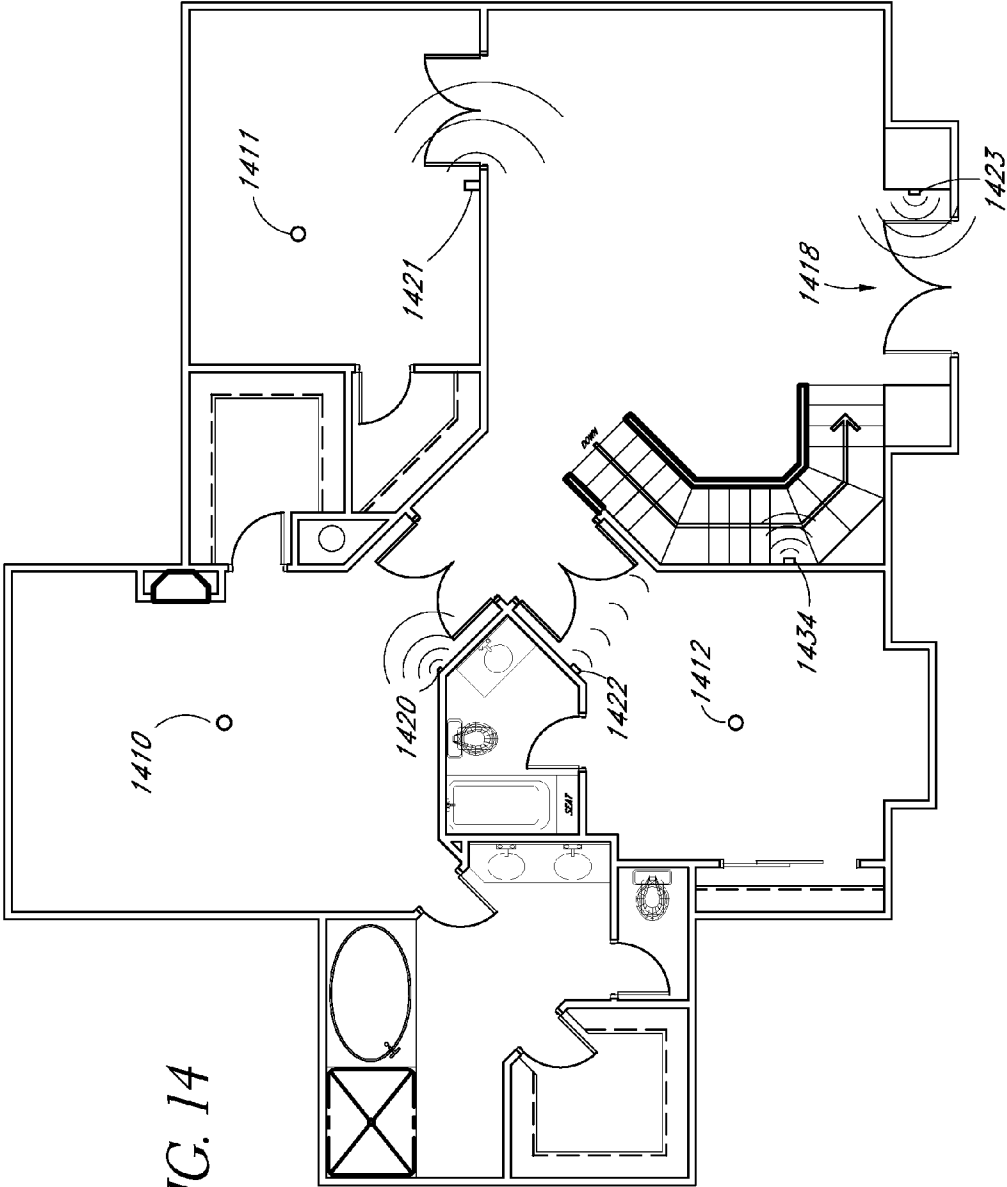

FIG. 14

**SYSTEM AND METHOD FOR
COMPUTER-CONTROLLED PET WATER
DISPENSER**

REFERENCE TO RELATED APPLICATIONS

[0001] This application is a divisional of application Ser. No. 11/417,394, filed May 3, 2006, titled "SYSTEM AND METHOD FOR COMPUTER-CONTROLLED PET WATER DISPENSER, now U.S. Pat. No. 7,380,518, which is a divisional of application Ser. No. 10/893,549, filed Jul. 15, 2004, titled "TRAINING, MANAGEMENT, AND/OR ENTERTAINMENT SYSTEM FOR CANINES, FELINES, OR OTHER ANIMALS," the entire contents of which is hereby incorporated by reference.

BACKGROUND OF THE INVENTION

[0002] 1. Field of the Invention

[0003] The present invention relates to systems for computer-aided training and management of dogs, cats, and other animals.

[0004] 2. Description of the Related Art

[0005] Electronic dog training collars that provide warning sounds, followed by some form of punishment for the purpose of training dogs not to engage in nuisance barking are well known. This type of system is activated when a dog's barking sound is picked up from the dog's throat area by a sound-sensing device located on a dog collar. Electronic dog training collars that provide warning sounds, followed by some form of punishment for the purpose of training dogs to stay within an established area are also well known. This type of system is activated when a radio receiver in the collar picks up a signal transmitted through a buried wire antenna. This type of training device does not provide a method for allowing the dog to return to within the established area in the event it escapes, without receiving correction. Another type of electronic dog training collar provides warning sounds, then some form of punishment when behavioral problems are visually detected by the dog trainer who activates a radio transmitter contained within a handheld enclosure. This signal, in turn, is received by a dog collar and the correction sequence is initiated. Some training collars of this type have a tilt switch which senses whether a dog is moving or standing still (pointing).

[0006] These and other prior art systems are limited in capability and are primarily designed to correct specific unwanted behaviors. Such systems are geared towards giving the dog a negative stimulus (punishment) when the unwanted behavior occurs. The prior art systems, aside from keeping the dog in the yard, are not concerned with protecting the happiness, health and well-being of the dog (or other animal). Moreover, it is well known that punishment training is a poor method of training and often leads to behavioral problems. Dogs have an innate desire to please, and thus the best trainers know to base the training on reward and encouragement, and to use punishment sparingly.

SUMMARY

[0007] These and other problems are solved by a computer-aided training and management system that uses a computer or other processor in wireless communication with an instrumented dog collar and/or optionally, one or more dog interaction devices, such as, for example, video monitors, loudspeakers, video cameras, training toys (e.g., ball, bone,

moving toy, etc.), an animatronics "trainer," a treat dispenser, a food dispensing and monitoring device, a water dispensing and monitoring device, tracking devices, a dog door, dog-monitoring doghouse, a dog-monitoring dog toilet, etc. In one embodiment, an instrumented dog collar is in two-way communication with a central computer system.

[0008] In one embodiment, a video device (or devices) and/or loudspeakers are used to provide training commands. The dog collar and/or one or more training toys, video monitors, etc. are fitted with wireless instrumentation to provide feedback regarding the dog's response to the training commands. In one embodiment, a computer-controlled treat dispenser is used to reward the dog. The training system can be used to entertain the dog, to train the dog to perform specific tasks, to train behaviors, and/or to increase the dog's vocabulary.

[0009] In one embodiment, a food dispensing and monitoring device and/or a water dispensing and monitoring device are provide to feed the dog and to monitor the dog's health and well-being by measuring the dogs intake of food and water. In one embodiment, tracking devices such, as for example, Infrared Red (IR) location, acoustic location, Radio Frequency (RF) location, GPS location, and/or inertial motion tracking are used to determine the dog's location. In one embodiment, the management system controls a "dog door" to allow the dog ingress and egress into a house or other structure.

[0010] In one embodiment, a wireless dog collar communicates with a Radio Frequency Identification (RFID) tag implanted in the dog and relays information from the RFID tag to the computer monitoring system. In one embodiment the RFID tag includes a temperature sensor to allow the monitoring system to monitor the dog's temperature. In one embodiment the RFID tag includes one or more biometric sensors to measure the dog's health and well-being, such as for example, temperature, blood pressure, pulse, respiration, etc.

[0011] In one embodiment, the animal management system includes a computer system provided to a first wireless communication transceiver and an animal collar provided to a second wireless communication transceiver. The animal collar has an identification code and is configured to communicate with the computer system using two-way handshaking communication such that the computer system can send commands to the animal collar and receive acknowledgement of the commands from the animal collar. The animal collar can send data to the computer system and receive acknowledgement from the computer system according to the identification code. The computer system is configured to send commands to the animal collar and to receive data from the animal collar related to one or more actions of a animal wearing the animal collar. The computer system is configured to keep records of at least a portion of the animal's actions.

[0012] In one embodiment, the animal collar includes at least one of, an acoustic input device, an acoustic output device, a vibrator device, an odor output device an infrared receiver, an infrared transmitter, an RFID tag reader, a GPS receiver, an inertial motion unit (e.g., accelerometers or gyroscopes).

[0013] In one embodiment, the animal management system includes at least one of, an RF location system, a computer-controlled treat dispenser, a computer-controlled water dispenser, a computer-controlled food dispenser, computer-controlled animal toilet, a computer-controlled animal house, a

video monitor. In one embodiment, the animal management system includes at least one animal toy configured to wirelessly communicate with the computer system. In one embodiment, the wireless toy includes at least one of, a light, an acoustic input device, an acoustic output device, a touch (or usage) sensor, a motion sensor, a location tracking system.

[0014] In one embodiment, the animal management system includes one or more location system units disposed about an area, such as, for example, a house, barn, yard, ranch, etc. In one embodiment, the location system units use infrared radiation for location and tracking of the animal collar. In one embodiment, the location system units use acoustic waves for location and tracking of the animal collar. In one embodiment, the location system units use electromagnetic waves for location and tracking of the animal collar. In one embodiment, the location system units are also configured to operate as motion detectors for a home security system.

BRIEF DESCRIPTION OF THE DRAWINGS

[0015] FIG. 1 shows various elements of a dog training and management system.

[0016] FIG. 2 is a block diagram of the dog collar.

[0017] FIG. 3 is a block diagram of the dog collar from FIG. 2 with the addition of location finding systems and a second RF transceiver for communicating with an RFID tag.

[0018] FIG. 4 is a block diagram of a dog toy.

[0019] FIG. 5 is a block diagram of the treat dispenser.

[0020] FIG. 6A shows a remote control for controlling the functions of the training and management system and for displaying data from the training and management system.

[0021] FIG. 6B is a block diagram of the remote control.

[0022] FIG. 7 is a block diagram of the dog house system.

[0023] FIG. 8A is a diagram of the food dispenser.

[0024] FIG. 8B is a block diagram of the food dispenser.

[0025] FIG. 9 is a block diagram of the water dispenser.

[0026] FIG. 10 is a diagram of one embodiment of the dog toilet.

[0027] FIG. 11 is a block diagram of a repeater unit.

[0028] FIG. 12 is a block diagram of the base unit.

[0029] FIG. 13 is a block diagram of a ball tossing unit used to play "fetch" with the dog.

[0030] FIG. 14 is a architectural-type drawing of the floor plan of a portion of a house showing examples of placement of locations sensors to sense the movement of the dog around the house.

DETAILED DESCRIPTION

[0031] FIG. 1 shows various elements of a dog training and management system 100 for managing a pet or animal such as a dog 101. For purposes of explanation, and not by way of limitation, the system 100 is described herein as a training system and a dog management system. One of ordinary skill in the art will recognize that various aspects of the system 100 can also be used for cats, other pets, farm animals, livestock, zoo animals, etc. The system 100 includes a computer system 103 to control the system 100 and, to collect data, and to provide data for the owner/trainer. The system typically includes a wireless collar 102 and a wireless base unit 104. The base unit 104 is provided to the computer 103 and allows the computer 103 to communicate with the collar 102. In one embodiment, the collar 102 communicates with a Radio Frequency ID (RFID) tag embedded in the dog 101. The RFID tag provides an identification code to identify the dog 101.

The collar 102 reads the RFID tag and relays the information from the RFID tag to the computer 103. In one embodiment, the RFID tag includes one or more biometric sensors to allow the computer 103 to monitor the health and condition of the dog 101. In one embodiment the RFID tag includes a temperature sensor to allow the monitoring system to monitor the dog's temperature. In one embodiment the RFID tag includes one or more biometric sensors to measure the dog's health and well-being, such as for example, temperature, blood pressure, pulse, respiration, blood oxygenation, etc.

[0032] The system 100 can also include one or more of the following optional devices: one or more video monitors 105, one or more loudspeakers 107, one or more video cameras 106, one or more RF training toys (e.g., a ball 114, a bone 116, a moving toy 115, etc.), an animatronics "trainer" 123, and a treat dispenser 122. The system 100 can further include one or more of the following optional devices: a remote control/display 112 for displaying the dog's location, a food dispensing and monitoring device 121, a water dispensing and monitoring device 120, one or more systems for locating the dog, one or more RF repeaters 113, one or more dog-door controllers 111, a dog-monitoring doghouse 119, a dog-monitoring dog toilet 117, and ambient condition sensors (e.g., rain, wind, temperature, daylight, etc.) 129. In one embodiment, the ambient condition sensors are wireless sensors that communicate wirelessly with the computer system 103.

[0033] In one embodiment, the system 100 can be used as a computerized training system for training the dog 101. During training, the system 100 provides training commands or instructions to the dog 101. Audio commands can be provide through the loudspeakers 107, through a loudspeaker in the collar 102, and/or through audio devices (e.g., loudspeakers, buzzers, etc.) in the dog toys 114-116. Visual commands can be provided by the monitor 105, by an animatronics trainer 123, and/or by visual display devices (e.g., lights in the toys 114-116, lights on the toilet 117, dog house 119, dispensers 121-122) etc. The dog tracking system described below can be used to provide corrective commands when the dog 101 is not performing correctly and/or to provide encouragement then the dog 101 is performing correctly.

[0034] In one embodiment, a modem 130 is provided for making connections with the telephone system, to allow the system 100 to communicate with an owner/trainer through cellular telephone, text messaging, pager, etc. A network connection 108 (e.g., an Internet connection, local area network connection, wide area network connection, etc.) is provided to allow the owner/trainer to communicate with the system 100 and to allow the system 100 to receive updated software, updated training regimens, etc.

[0035] In one embodiment, the collar 102 provides positive reinforcement (e.g., clicker sounds, "good dog" sounds, pleasing sounds, pleasing smells, treats, etc.) and/or negative reinforcement commands (e.g., unpleasant sounds, electric shock, unpleasant vibration, unpleasant smells, etc.)

[0036] The dog toys provide touch and/or motion feedback to the training system 100. The training system 100 delivers a treat to the dog using the treat dispenser 122 when it receives confirmation that the dog has properly performed the command. In one embodiment, an Inertial Motion Unit (IMU) in the dog collar 102 and/or the video cameras 106 are be used to determine when the dog performs a desired action (e.g., sit, roll over, lie down, retrieve a toy, etc.). A location system described below can be used to keep the dog in a desired area

and out of “off limits” areas. In one embodiment, the location system uses multiple inputs to determine the dog’s location.

[0037] In one embodiment, the dog toys 114-116 are adapted to specialized training such as, for example, bomb-sniffing, drug-sniffing, etc.

[0038] In one embodiment, the animatronics trainer 123 is configured to smell like a human (e.g., by placing clothes worn by the owner/trainer on the animatronics trainer). In one embodiment, the animatronics trainer 123 is configured to speak to the dog. In one embodiment, the animatronics trainer 123 is configured to provide treats to the dog. In one embodiment, the animatronics trainer 123 is mobile and is configured to walk the dog. In one embodiment, the animatronics trainer 123 is configured to be used to teach the dog to heel.

[0039] In one embodiment, the system 100 uses the sensors 129 to detect fire or smoke. In one embodiment, the system 100 receives alarm data from a home alarm system. In one embodiment, the microphone 204 is used to detect a fire alarm. When the system 100 detects a fire or smoke alarm, the system 100 can open the dog door 111, instruct the dog to leave, close the dog door 111 after the dog has left, and notify the owner/trainer. The owner/trainer can be notified by using the loudspeakers 107, by telephone, pager, and/or text messaging using the modem 130 to connect with the telephone system, and/or by using the network connection 108 (e.g., email instant messaging, etc.). The modem 130 is configured to place a telephone call and then communicate with the owner using data (e.g., in the case of text messaging) and/or synthesized voice. The modem 130 can also be used by the owner/trainer 130 to contact the computer system 103 and control the system 100 using voice recognition commands and/or data.

[0040] In one embodiment, the system 100 uses the video cameras 106 to record videos of the dog’s training. These videos can be played back for the owner/trainer to help the owner/trainer understand how the training is progressing and to spot problems.

[0041] For example, the system 100 can be used, for example, to train the dog 101 to understand one or more of the following commands/actions:

[0042] A. General Commands

- [0043] Sit—Stay
- [0044] Come Here (or Come, or Here)
- [0045] Down—Stay
- [0046] Heel
- [0047] Stand—Stay
- [0048] Stand
- [0049] Don’t Growl
- [0050] Stand Here/Stand By Me
- [0051] Lie Down
- [0052] Up
- [0053] Down
- [0054] Shake Hands
- [0055] Roll Over
- [0056] No Paw
- [0057] Slow-Time (walking command)
- [0058] Fast-Time (walking command)
- [0059] Take-Time (walking command—Slow Down)
- [0060] Catch/Fetch
- [0061] Speak/Bark
- [0062] Retrieve
- [0063] Eat Food
- [0064] Don’t Do That
- [0065] No

- [0066] Go Ahead
- [0067] O.K.
- [0068] Track
- [0069] Go Out
- [0070] Let Go
- [0071] Look Back
- [0072] Get Out
- [0073] Kennel/Crate (“Go to the kennel, etc.”)
- [0074] Bad Dog
- [0075] Come Back
- [0076] Get Ball
- [0077] Nice Dog
- [0078] Good Dog/Nice Dog
- [0079] Quiet
- [0080] Go To Sleep
- [0081] Walk/Go For A Walk
- [0082] Run
- [0083] Let’s Play
- [0084] Put That Down
- [0085] Don’t Shake Hands
- [0086] Stop Barking
- [0087] Don’t Go Out/Don’t Go Outside/Don’t Go Out Door
- [0088] T.V. (e.g., stop the dog from barking at the TV or the doorbell)
- [0089] Go To The Corner
- [0090] Leave It/Drop It

[0091] B. Military/Police-Type Commands

- [0092] Search
- [0093] Bite
- [0094] Hold
- [0095] Jump
- [0096] Track
- [0097] Blind Search
- [0098] Guard
- [0099] Go Ahead
- [0100] Let Go
- [0101] Stop/Halt
- [0102] Article Search (A command for the dog to search for
- [0103] contraband or other illegal items at an airport or another facility)
- [0104] Go Inside
- [0105] Go Outside
- [0106] Don’t Do That
- [0107] Stand
- [0108] Speak/Bark
- [0109] Attack

[0110] C. Situations in Which Control of the Dog’s Behavior Must be Altered:

- [0111] Remain In Yard/Stay In The Yard (or similar area)
- [0112] Housebreaking
- [0113] Inappropriate Dominant Behavior
- [0114] Staying Off The Furniture
- [0115] Staying Off Guests/Don’t Jump On Guests/Don’t Bother Guests
- [0116] Eliminate Chewing Furniture
- [0117] Stop Inappropriate Barking
- [0118] Stay Out Of The Trash Cans
- [0119] Get The Newspaper
- [0120] Get Bedroom Slippers
- [0121] Don’t Defecate/Urinate In House
- [0122] Eliminate Chewing Of Household Items

[0123] Do Not Exhibit Aggressive Behavior Toward Visitors

[0124] Don't Chase Cars or Other Moving Objects

[0125] Eliminate Nipping/Snapping Behaviors

[0126] Eliminate Or Prevent Excessive Fear Reactions or 'Paranoia' in the dog.

[0127] Eliminate Negative Behaviors Such As Excessive, Unfounded Whining, Whimpering, or Vocalizing Other Similar Sounds

[0128] In Inappropriate Situations

[0129] Eliminate Uncontrolled (and sometimes destructive) Over-energetic Or Separation Anxiety-Related Behaviors

[0130] The above lists are not exhaustive, but are intended to illustrate types of training that the system **100** can provide. The dog's response to commands is monitored by the system **100** by using data from the collar **102**, from the toys and other devices **114-123**, and/or by video processing of from the one or more video cameras **106**. In addition, the dog's response to commands can be determined by the owner/trainer in real time and by watching video obtained by the one or more video cameras **106**. The system **100** can be used to train the dog to obey new commands and/or to reinforce commands the dog already understands. In one embodiment, a trainer works with the dog **101** and the system **100** to get the dog accustomed to the system **100** and to give the dog a starting vocabulary of basic commands (e.g. sit, stop, get the lighted toy, etc.) and then the system **100** can be used to reinforce the basic commands and to teach the dog new commands.

[0131] FIG. 2 is a block diagram of the collar **102**. In the collar **102**, a sound sensing device (e.g., a microphone) **204**, a vibration device **205**, a sound producing device (e.g., a loudspeaker) **206**, an electric shock device **207**, and a first RF transceiver **202** are provided to a processor **201**. The sound sensing device is configured to sense sound waves (sonic and/or ultrasonic) such as, for example, a microphone, a transducer, etc. For convenience, and without limitation, the sound sensing device is referred to herein as a microphone with the understanding that other acoustic transducers can be used as well. For convenience, and without limitation, the sound producing device is referred to herein as a loudspeaker with the understanding that the sound producing device is configured to produce sound waves (sonic and/or ultrasonic) such as, for example, a loudspeaker, a transducer, a buzzer, a clicker, etc. A power source **203** provides power for powering the microphone **204**, the vibration device **205**, the loudspeaker **206** and the electric shock device **207**, the first RF transceiver **202** and the processor **201**. In one embodiment, each of the microphone **204**, the vibration device **205**, the loudspeaker **206** and the electric shock device **207** are optional and can be omitted. The collar **102** can also include an odor/treat dispensing device **210** for providing pleasant smells, treats, and/or unpleasant smells so the dog **101**. The collar **102** can also include a light (not shown) for providing visual indications to the dog **101**, to the trainer, or to the video cameras **106**. In one embodiment a tamper sensor **230** is also provided.

[0132] The microphone **204** is used to pick up sound waves such as, for example, sounds produced by the dog **101**, sounds produced by other dogs, and/or acoustic waves produced by an acoustic location device (sonic or ultrasonic), etc. The processor **201** processes the sounds picked up by the microphone and, if needed, sends processed data to the computer system **103** for further processing. The loudspeaker **206** is

used to produce pleasant and/or unpleasant sounds for the dog **101** and to provide commands to the dog **101**. The microphone **204** and/or loudspeaker **206** can also be used in connection with an acoustic location system to locate the dog using acoustic waves. In an acoustic location system, the microphone **204** and/or loudspeaker **206** communicate acoustically with acoustic sources or sensors placed about the house or yard to locate the dog **101**.

[0133] The vibrator is used to produce pleasant and/or unpleasant vibrations to the dog **101**. The electric shock device **207** is used to provide corrective shocks to the dog **101**. In one embodiment, the shock device **207** can provide a range of shocks from relatively mild to relatively harsh. In one embodiment, the computer system **103** instructs the processor **201** to control the electric shock device **207** to deliver a desired shock intensity.

[0134] The optional tamper sensor **230** senses when the collar has been tampered with (e.g., removed from the dog). In one embodiment, the optional dispenser **210** dispenses odors such as pleasant and/or pleasant odors to the dog **101**. In one embodiment, the optional dispenser **210** dispenses treats for the dog **101**.

[0135] The first RF transceiver **202** communicates with the base unit **104** either directly or through the repeaters **113**. In one embodiment, the RF transceiver **202** provides two-way communications such that the collar **102** can send information to the computer system **103** and receive commands from the computer system **103**. In one embodiment, the computer system **103** and the first RF transceiver **202** communicate using a handshake protocol, to verify that data is received.

[0136] FIG. 3 is a block diagram of the dog collar **102** from FIG. 2 with the addition of location finding systems and a second RF transceiver **309** for communicating with an RFID tag **310** imbedded in the dog **101**. In FIG. 3, the collar **102** includes one or more location and tracking systems, such as, for example, an IR system **301**, a GPS location system **302**, an IMU **303** and/or a third RF transceiver **304**. The tracking systems can be used alone or in combination to ascertain the location of the dog. The IR system **301** the GPS location system **302**, the IMU **303**, and the third RF transceiver **304** are provided to the processor **201** and powered by the power source **203**. The processor **201** controls operation of the IR system **301**, the GPS location system **302**, the IMU **303**, and the third RF transceiver and controls when the power source delivers power to the IR system **301**, the GPS location system **302** and the IMU **303**. The first second and third RF transceivers are separated in FIG. 3 for purposes of description, and not by way of limitation. In one embodiment, the first RF transceiver **202**, and/or the second RF transceiver **309** and/or the third RF transceiver **304** are combined into one or more transceivers. In one embodiment, the first RF transceiver **202**, and/or the second RF transceiver **309** and/or the third RF transceiver **304** operate at different frequencies.

[0137] The second RF transceiver **309** communicates with the RFID tag **310** to obtain information (e.g., identification, temperature, pulse rate, biometric information, etc.) from the RFID tag **310**.

[0138] In one embodiment, the third RF transceiver **304** is a receive-only device that receives radio location signals from one or more radio location transmitters as part of a radio location system. In an alternative embodiment, the third RF transceiver **304** is a transmit-only device that transmits radio location signals to one or more radio location receivers as part of a radio location system. In an alternative embodiment, the

third RF transceiver **304** transmits radio location signals to and receives radio location signals from one or more radio location transceivers as part of a radio location system. Techniques for radio location systems such as, for example, GPS, DECCA, LORAN, etc. are known in the art. Data from the radio location system is provided to the computer system **103** to allow the computer system **103** to determine the location of the collar **102**. In one embodiment, radio location is provided by measuring a strength of a signal transmitted by the collar **102** and received by one or more repeaters **113** to estimate distance between the repeaters and the collar **102**. In one embodiment, radio location is provided by measuring a strength of signals transmitted by one or more repeaters **113** and received by the collar **102** to estimate distance between the repeaters and the collar **102**. In one embodiment, a time delay corresponding to radio frequency propagation between the repeaters **113** and the collar **102** is used to estimate the location of the collar **102**.

[0139] The various location systems have benefits and drawbacks. In one embodiment, the system **100** uses a combination of one or more of a GPS system, an IMU, a radio-location system, an IR system, and an acoustic system, to locate the dog **101**. One or more of these systems are used synergistically to locate the dog **101** and to reduce the power consumed in the collar **102** by the location process.

[0140] The IMU **303** uses one or more accelerometers and/or gyroscopes to sense motion of the collar. The motion can be integrated to determine location. The IMU **303** provides relatively low power requirements and relatively high short-term accuracy. The IMU provides relatively lower long-term accuracy. An Inertial Motion Units (IMU) unit will work indoors or out, and typically consumes less power than other location systems. However, IMU systems are prone to drift over time and tend to loose accuracy if not recalibrated at regular intervals. In one embodiment is recalibrated from time to time by using data from one or more of the GPS, acoustic, IR, and/or RF location systems. In one embodiment the IMU **303** is used to reduce power requirements for the GPS, IR, and/or RF location systems. In one embodiment, the GPS, IR, and/or RF location systems are placed in a low-power or standby mode when the IMU **303** senses that the collar **102** is motionless or relatively motionless. If the IMU **303** senses that the collar **102** is relatively motionless (e.g., motionless or moving at a relatively low velocity) then the dog is either not moving or is moving slowly enough that tracking is not immediately needed. In one embodiment, the IMU **303** is a 3-axis system and thus motion of the collar **102** in any direction is sensed as motion and can be used to activate one or more of the other sensing systems. Thus, for example, if the dog has been lying down and then stands up, the “up” motion will be sensed by the IMU **303** and the collar will activate one or more tracking systems.

[0141] In one embodiment, the system **100** assumes that the dog **101** will not move at a relatively constant and relatively low velocity for any significant length of time. Thus, in one embodiment, the IMU self-calibrates to a constant offset error (e.g. a constant slope in the X, Y or Z direction) and a deviation from that constant X, Y offset error (e.g., a change in slope) is recognized as a movement by the dog **101**.

[0142] In one embodiment the IMU **303** is at least a 2-axis IMU that senses motion in at least two directions. In one embodiment the IMU **303** is at least a 3-axis IMU that senses motion in at least three directions. In one embodiment, the IMU **303** provides data to determine that the dog **101** has

rolled over, jumped, etc. In one embodiment, the IMU provides data used to determine the gait of the dog **101**, such as, for example, running, walking, going up stairs, going down stairs, trotting, limping, etc. In one embodiment, the IMU provides data used to determine head motions of the dog **101**, such as, for example, barking, retching, etc. In one embodiment, data from the IMU is used in connection with signal processing of audio signals from a microphone in the collar **102** to determine if the dog **101** is barking, retching, whimpering, drinking, choking, whining, etc.

[0143] For training, the IMU can be used alone or in combination with other tracking devices to obtain feedback on the motion of the dog **101**. Thus, for example, if the dog **101** is commanded to pick up the ball **114**, and the IMU senses that the dog **101** is moving towards the ball **114**, then the system **100** can provide positive feedback to the dog.

[0144] The IMU **303** can measure both dynamic acceleration as well as static acceleration forces, including acceleration due to gravity, so the IMU **303** can be used to measure tilt as well as horizontal and vertical motion. When the IMU **303** is oriented so both the X and Y axes are parallel to the earth's surface it can be used as a two axis tilt sensor with a roll and pitch axis. Ninety degrees of roll would indicate that the dog **101** is lying on its side. In addition, when the IMU **303** indicates no movement at all, regardless of the orientation of the dog **101**, the dog is asleep or inactive and the system is powered down, as described above. Thus, the IMU **303** can detect when the dog is not standing.

[0145] With regard to digging movements of the dog **101**, the IMU **303** can detect forward motion (dynamic motion) or lack of forward motion of the dog, in addition to tilt. If the IMU **303** detects that the dog's forward motion has stopped and a motion perpendicular to the main axis of the dog continues, the dog is digging. If this criteria is used in conjunction with IMU **303** recognition of a downward tilt toward the front of the dog's body, the digging motion is likely. Digging detection can be disabled automatically when the dog is laying down, rolling over, etc. With regard to jumping, the IMU **303** can be used to detect a movement essentially straight up, or up and slightly rearward, the dog is jumping up.

[0146] The microphone **204** is used to listen to the dog for barking, whimpering, cries of distress or pain, retching, etc. The IMU **303** (if provided) can be used in connection with the microphone **204** to help detect barking, retching, etc. and other sounds where a head movement is associated with the sound. In one embodiment, to reduce power consumption, the collar **102** performs a preliminary acoustic analysis and forwards suspicious results to the computer system **103** for more detailed processing. The microphone **204** can also be used with an optional ultrasonic (or acoustic) location system.

[0147] The collar **102** sends low-battery warnings to the computer system **103** to alert the owner/trainer that the collar **102** needs fresh batteries.

[0148] The loudspeaker **206** is used to provide training commands such as for example, spoken commands, positive reinforcement sounds (e.g. clicker sounds, “good dog” phrases, etc.), negative reinforcement sounds (e.g., unpleasant sounds), etc. The vibrator **205** can be used for varying levels of relatively mild negative reinforcement during training. The electric shock generator **207** can be used for mild to strong negative reinforcement.

[0149] The Global Positioning System (GPS) is accurate but often does not work well indoors, and sometimes does not have enough vertical accuracy to distinguish between floors

of a building. GPS receivers also require a certain amount of signal processing and such processing consumes power. In a limited-power device such as the dog collar **102**, the power consumed by a GPS system can reduce battery life. However, GPS has the advantage of being able to operate over a large area and is thus particularly useful when locating a dog that has escaped a confined area or is out of the range of other locating systems.

[0150] In one embodiment, the GPS system **302** operates in a standby mode and activates at regular intervals or when instructed to activate. The GPS system can be instructed by the computer **103** or the collar to activate. When activated, the GPS system obtains a position fix on the dog **101** (if GPS satellite signals are available) and updates the IMU. In one embodiment, a GPS system is also provided to the computer system **103**. The computer system uses data from its GPS system to send location and/or timing data to the GPS system **302** in the collar **102** allowing the GPS system **302** to warm start faster, obtain a fix more quickly, and therefore use less power.

[0151] In one embodiment, location system units **118** are placed about a house or kennel to locate movement and location of the dog **101**. In one embodiment, location system units **118** send infrared light, acoustic waves, and/or electromagnetic waves to one or more sensors on the collar **102** in order to conserve power in the collar **102**. In one embodiment, the collar **102** sends infrared light, acoustic waves, and/or electromagnetic waves to the location system units **118** in order to conserve power in the units **118**.

[0152] For example, location system units **118** placed near doorways or in hallways (see e.g., FIG. **14**) can be used to determine when the dog **101** moves from one room to another. Even if the dog cannot be exactly located within the room (e.g., due to blind spots), a location system unit **118** placed to sense the movement of the dog though the doorway allows the system **100** to know which room the dog is in by watching the dog **101** move from room to room.

[0153] In one embodiment, each location transmitter (whether in the collar **102** or the location system units **118**) sends a coded pattern of pulses to allow the transmitter to be identified. In one embodiment, in order to conserve power, the location receiver (whether in the collar **102** or the location system units **118**) notifies the computer system **103** whenever the pattern of received pulses changes. Thus, for example, when the location receiver enters the range of a first location transmitter that transmits a first code, the location receiver sends a "location sensor message" to the computer system **103**. In one embodiment, the location receiver does not send further location sensor messages so long as the location receiver continues to receive the pattern of pulses from the same location transmitter. In an alternate embodiment, the location receiver sends location sensor messages to the computer system **103** on a periodic basis so long as the location receiver continues to receive the pattern of pulses from the same transmitter. The location receiver sends a "location sensor lost" message when the pattern of pulses stops.

[0154] Motion detectors inside and/or outside a house are commonly provided in connection with home security systems. In one embodiment, the location system units **118** are configured as motion detectors, and the IR system **301** (e.g., transmitter and/or receiver) on the collar **102** communicates with such IR motion detectors to avoid false alarms that would otherwise occur when the motion detector detects the movement of the dog. In one embodiment, the collar trans-

mits an IR signal that the motion detector recognizes as coming from the collar **102** and thus the motion detector knows that the motion it is sensing is due to the dog and not an intruder. In one embodiment, when the collar **102** detects an IR transmission from a motion detector, the collar transmits a response IR signal that the motion detector recognizes. In one embodiment, the IR tracking system used by the system **100** is also used as part of a home security system to track both the movement of the dog and other movements in the house that are not due to the dog. Acoustic motion detectors and/or microwave motion detectors can be used with the collar **102** similarly to the IR motion detectors.

[0155] Unlike VHF radio-based systems (e.g., GPS or VHF radio-location systems, etc.), IR, acoustic, and/or millimeter wave and some microwave systems do not penetrate walls very effectively. Thus, an IR, acoustic, and/or microwave/millimeter wave system can be used in the system **100** to locate the dog **101** without having a map of the house or kennel. Radio-based systems that operate at frequencies that penetrate walls can be used in connection with a map of the house

[0156] In one embodiment, the IR system is replaced or augmented by a sonic or ultrasonic system. In one embodiment, the operation of the sonic or ultrasonic system is similar to that of the IR system except that the waves are sound waves instead of infrared waves. In one embodiment, the frequency of the sound waves used is above the frequency that can be heard by dogs or cats and thus does not disturb the animals. Although not immune to blind spots, the sonic or ultrasonic system is typically less susceptible to blind spots than the infrared system.

[0157] In one embodiment, the sonic or ultrasonic system includes a ranging function similar to that of an RF system. In one embodiment, the ranging function uses a two-frequency phase comparison system to measure distance from the sound transmitter to the sound receiver.

[0158] In one embodiment, the IR system **301** can be used to send IR signals to the video cameras **106**.

[0159] In one embodiment, the dog **101** is contained in the containment area by **130** by a boundary wire antenna. The collar **102** receives encoded pseudo-random electromagnetic signals from the boundary wire antenna and a correction stimulus is applied when the dog **101** moves near to and through the containment wire antenna to the "outside" area. In one embodiment, the collar **102** sends a warning message to the computer system **103** when the dog **101** gets too near the boundary wire antenna. If the dog moves outside the boundary area, the correction capability is disabled by the computer system **103** to allow the dog reentry into the containment area, without receiving correction. The correction capability is then restored by the computer system **103**.

[0160] In one embodiment, the boundary wire is configured as two or more wires arranged as an inner wire (or wires) and an outer wire (or wires). The collar detects the transmissions from the two or more wires using amplitude and/or phase comparisons to determine if the dog is closer to the inner wire(s) and therefore inside the boundary, or closer to the outer wire(s) and therefore outside the boundary.

[0161] In one embodiment, the collar determines the strength of the containment signal to find out how close the dog **101** is to the containment fence. If the signal strength falls within a warning range, a negative training stimulus (e.g., a shock, vibration, etc.) is provided to deter further movement in that direction. Should this fail and the containment signal

grows stronger, signaling a move closer towards the fence, then a stronger negative stimulus is provided (e.g., a stronger shock). If the dog **101** chooses to ignore the warnings and moves over the containment fence, then the change in phase of the containment signal indicates that the dog is outside the containment area

[0162] If the dog moves outside the range of the containment signal and outside the containment area, the collar provides a voice message (for example, "GO HOME!") from the loudspeaker **206**. If the dog **101** moves back towards the containment fence to return within the containment region **130** and the containment signal is received by the collar **102**, the collar **102** sends a message to the computer system **103** that the dog is outside the containment area and moving in. This tells the computer system **103** to cancel the audible beep (or voice message) and suppresses any stimulus to allow the dog to return. When the dog returns within the containment fence and within the allowed region, computer system **103** and collar **102** resume normal operation.

[0163] In embodiment, the dog can be trained to remain within the containment area **130** using GPS. A GPS boundary **130** is configured to the computer system **103** and provided to the collar **102**. The dog's position are obtained several times per second. When the dog's location is too close to the edge of the boundary **130**, the correction sequence is initiated.

[0164] When the dog moves towards or exits the boundary of the containment area **130**, the collar **102** performs the containment function as described above with various warnings and corrections. The GPS boundary can be used with or without a boundary wire. The IMU **303** can be used with intermittent updates by the GPS system **303** as described above.

[0165] In one embodiment, the system **100** locates the dog periodically (e.g., communicates with the collar **102**) and alerts the owner/trainer if the dog cannot be found (e.g., if the system **100** cannot contact the collar **102**). In one embodiment, the system **100** locates the dog and alerts the owner/trainer if the dog has escaped or is in an area that is off-limits to the dog.

[0166] In one embodiment, the system **100** is configured to keep two or more dogs (or cats) apart (e.g., to avoid fights or interference with play, training, etc.). In one embodiment, the system **100** uses the microphone **204** to detect sounds corresponding to a dog (or cat) fight and applies corrective punishment to stop the fight and prevent future fights.

[0167] FIG. 4 is a block diagram of a dog toy **400**, such as, for example, the dog toys **114-116** shown in FIG. 1. In the toy **400**, a sound sensing device (e.g., a microphone) **404**, a vibration device **405**, a sound producing device (e.g., a loudspeaker) **406**, an electric shock device **407**, a light **408**, a touch detector **409**, a motion detector **413**, and a first RF transceiver **402** are provided to a processor **401**. A sound sensing device (not shown) can also be provided to the processor **201**. The sound producing device is configured to produce sound waves (sonic and/or ultrasonic) such as, for example, a loudspeaker, a transducer, a buzzer, a clicker, etc. For convenience, and without limitation, the sound producing device **406** is referred to herein as a loudspeaker **406**. A power source **403** provides power for powering the vibration device **405**, the loudspeaker **406** the electric shock device **407**, the first RF transceiver **402**, the light **408**, the touch detector **409**, the motion detector **413**, and the processor **201**. In one embodiment, each of the sound producing device (not shown), the vibration device **405**, the loudspeaker **406** and the

electric shock device **407** are separately optional and each can be omitted depending on the desired system configuration. The toy **400** can also include an odor dispensing device (not shown) for providing pleasant or unpleasant smells so the dog **101**. The toy **400** can also include the light **408** for providing visual indications to the dog **101**, to the trainer, or to the video cameras **106**. The light **408** can be configured as one or more incandescent lights, one or more LEDs, one or more strobe lights, etc. In one embodiment, the toy **400** also includes one or more location and tracking devices, such as, for example, the IR system **301**, the GPS **302**, the IMU **303**, and or the third RF transceiver **304** described in connection with FIG. 3. An optional motion actuator **402** can be used to provide motion of a portion of the toy (e.g., to move a string for playing with a cat, a ball launcher for launching a ball for a dog to fetch, etc.) or to move the entire toy (e.g., to move the toy about the room or yard as part of the dog's training or as part of a game to entertain the dog).

[0168] As part of a training system or game, the computer system **103** instructs the dog **101** to get a selected toy. The computer system can use the light **408** and/or the loudspeaker **406** to attract the attention of the dog **101**. If the dog selects the right toy, then the touch sensor **409** and/or the motion detector **413** sense the dog's selection and the information is communicated back to the computer system **103**. If the dog selects the right toy, then the computer system **103** can reward the dog. If the dog selects the wrong toy, then the computer system **103** can use the vibrator **405**, the electric shock device **407**, or unpleasant sounds from the loudspeaker **406** to provide negative reinforcement to the dog **101**. In one embodiment, the computer system uses negative reinforcement judiciously, if at all, based on a training program that punishes the dog when the training program deems punishment is constructive. In one embodiment, the training program running on the computer system **103** learns the characteristics and temperament of the dog **101** and uses such knowledge in making a decision regarding punishment. In one embodiment, a trainer configures the computer system **103** to punish the dog **101** in various circumstances and to forego punishment in other circumstances. In one embodiment, the computer system **103** reads the RFID tag **310** (though the collar **102**) to establish the identity of the dog **101** and to load the proper training parameters for the dog **101**.

[0169] In one embodiment, the dog toys **114-116** include one or more obstacle course-type devices that allow the dog to jump through hoops, over bars, up ramps, etc. The computer **103** guides the dog through the obstacle course using lights and/or sounds provided on the obstacle course devices. In one embodiment, the system **100** uses the video system **106** to track the dog through the obstacle course. In one embodiment, the obstacle course devices are provided with sensors **409** to register the passage of the dog and the system tracks the dog through the obstacle course by the device sensors. In one embodiment, the obstacle course includes a hoop wherein the sensor **409** is configured as an optical interrupter that detects the passage of the dog through the hoop when the dog breaks an optical beam across the hoop.

[0170] The system **100** can run the dog through an obstacle course that includes several such obstacles by varying the course, speed through the course, etc. The system **100** can record the dog's ability to run the course, the dog's speed through the course, etc. by sensing as the dog passes over or through each obstacle.

[0171] In one embodiment, the elements of FIG. 4 are configured as a generic electronics module that can be provided to dog toys provided by the owner/trainer.

[0172] In one embodiment, the system 100 can be used to communicate with the dog through phonetic sounds, such as, for example, through bark recognition. The system 100 receives feedback regarding the dogs movements, actions, and environments, and can thus learn various aspects of the dog's behavior and vocabulary. In addition the system 100 can interact with the dog to train the dog using a desired vocabulary or set of phonetic sounds. In one embodiment, the system 100 is configured to recognize sounds made by the dog (e.g., barking, whimpering, cries of pain, choking sounds, etc.) the microphone in the collar 102 and the signal processing capabilities in the collar 102 and in the processor 130. This dog "speech recognition" system can base its discrimination on acoustic features, such as, for example, formant structure, pitch, loudness, spectral analysis, etc. When the computer recognizes the message behind the sounds made by the dog, then the system 130 can respond accordingly, either by providing a message to the owner/trainer or by taking action in the dog's environment. Thus, for example, if the dog emits a cry of pain, a choking sound, or the like, the system 130 will raise an alarm and attempt to contact the owner or trainer. In one embodiment, the system 130 is provided with communications access (e.g., Internet access, cellular telephone access, pager access, etc.) to contact the owner/trainer. In an alternate example, if the dog makes a sound indicating that it needs to be let out, then the system 130 can release a latch on the dog door 111.

[0173] In one embodiment, the system 100 recognizes the speech of dog 101 and thus if a strange dog or other animal enters the area and makes sounds, the system 100 can recognize that a strange dog or other animal is in the area and take appropriate action (e.g., lock the dog door 111, notify the owner/trainer, etc.)

[0174] Communicating commands or instructions to a dog typically involve training because dogs do not instinctively understand human language. In one embodiment, the system 100 trains the dog 101 using human speech commands, thus allowing the owner/trainer to easily interact with the dog 101. In one embodiment, the system 100 also communicates with the dog 101 using sounds (e.g., bark-like sounds) that are more similar to a dog's instincts. Thus, in one embodiment, the system 100 produces sounds (e.g., barking sounds, etc.) that a dog will understand more easily than human speech.

[0175] In one embodiment, the system 100 cares for the dog's well being when the owner/trainer is away, asleep, or otherwise occupied. Thus, for example, if the dog 101 makes a sound and/or motions indicating that it is bored, or wants to play, the system 100 will initiate a game with the dog. In one embodiment, one or more of the toys 114-116 are self-propelled (or can throw a ball) and the system 100 can play games such as "fetch" with the dog 101. During the game, the dog is rewarded by pleasing sounds, encouraging comments, treats from the treat dispenser 122 etc. Several videos are currently available for entertaining dogs, but playing such videos requires manual interaction by the owner/trainer. In one embodiment, the audio-video display system (105,107) is used to play videos of other dogs playing, and thus entertaining and holding the dog's attention. In one embodiment, the system 100 plays a video when the dog indicates that it is bored or wants to play.

[0176] In one embodiment, the system 100 uses the sensors 129 to monitor ambient conditions such as, for example, indoor temperature, outdoor temperature, rain, humidity, precipitation, daylight, etc. Uses the information to look after the dogs well being. Thus for example, if the system 100 determines that it is raining or too hot outside, the system 100 can call the dog inside (using, for example, the loudspeaker on the collar 102) and latch the dog door 111. Using the daylight sensor and/or time of day available from the computer 103, the system 100 can be used to manage the dog differently depending on whether it is light or dark outside, morning or evening, etc. Thus for example, the system 100 can be instructed to allow the dog more leeway for barking during the day than during the night. For example, in one embodiment, if the system 100 senses that the dog is barking during the day, the system can use mild correction to stop the barking. By contrast, if the system senses that the dog is barking at night, then the system can instruct the dog to go inside and/or apply relatively stronger correction.

[0177] FIG. 6 is a block diagram of the remote control 112 for controlling the system 100 and for receiving information from the system 100. The remote control 112 includes a microphone 604, a loudspeaker 606, a keyboard (or keypad) 612, a display 613, and a first RF transceiver 602, all provided to a processor 601.

[0178] The remote control 112 communicates with the computer system 103 using the RF transceiver 602 to receive status information and to send commands to the system 100. Using the remote control 112, the owner/trainer can check on the location, health, and status of the dog 101. The owner/trainer can also use the remote control 112 to send commands to the system 100 and to the dog 101. For, example, using the microphone 604, the owner/trainer can speak to the dog 101. In one embodiment, the computer system 103 sends display information to the display 613 to show the location of the dog 101. If the location of the dog cannot be ascertained, the system 100 can send a "dog not found" message and attempt to contact the owner/trainer using the network connection 108, the modem 130, and/or the remote control 112. If the system 100 determines that the dog has escaped, the system 100 can send a "dog lost" message and attempt to contact the owner/trainer using the network connection 108, the modem 130, and/or the remote control 112.

[0179] FIG. 7 is a block diagram of the dog house system 119 that includes a microphone 704, a loudspeaker 706, an IR sensor 701, a temperature sensor 710, a ventilation fan 711, a video monitor 713, a first RF transceiver 702, a second RF transceiver 709, and a video camera 717, all provided to a processor 701. The microphone 704, the loudspeaker 706, the IR sensor 701, the temperature sensor 710, the ventilation fan 711, the video monitor 713, the first RF transceiver 702, the second RF transceiver 709, and the video camera 717 are separately optional items and each can be omitted depending on the configuration and capabilities desired in the dog house system 119.

[0180] The dog house 119 includes many of the functions of the collar 102. Typically, the dog house 119 has more power available than the collar 102. Thus, the dog house 119 can take over many of the function of the collar 102 when the dog 101 is inside or near the dog house 119. For example, the dog house 119 can interrogate the dog's RFID chip 310, can provide communications to the computer system 103, can listen for barking or other sounds, etc. Thus in one embodiment, the computer system 103 selectively instructs the pro-

cessor 201 to disable (e.g., power down) functions of the collar 102 that can be handled by the dog house 119. Other functions, such as using the IMU 303 to detect head movements of the dog that cannot be handled by the dog house 119 remain active. In one embodiment, the video camera 717 is used in connection with video signal processing and image recognition to replace some or all of the functions of the IMU for tracking the dog 101 or sensing head movements while the dog 101 is in the doghouse 119.

[0181] The video monitor 713 can be used to provide visual commands to the dog. The video camera 717 can be used to provide a video feed (e.g., regular scan video, slow scan video, single frame video, etc.) to the owner or trainer thereby allowing the owner to keep watch over the dog 101 from a remote location on the remote control 112. In one embodiment, one or more audio/video systems (e.g., video monitors and loudspeakers) are provided with wireless receivers and provided throughout the house or yard to provide audio/visual commands to the dog. One or more video cameras can be used to provide a video feed (e.g., regular scan video, slow scan video, single frame video, etc.) to the owner or trainer thereby allowing the owner to keep watch over the dog 101 from a remote location on the remote control 112.

[0182] The temperature sensor 710 is used to monitor the temperature of the dog house 119. The fan 711 provides ventilation when the temperature in the doghouse 119 gets too warm. The fan can be controlled locally by the processor 701 or remotely by the computer system 103 by sending commands to the processor 701. The door latch 712 allows the monitoring system 100 to lock the dog 101 inside or out of the dog house as desired.

[0183] In one embodiment, the RF transceiver 702 provides a repeater function for the dog collar 102. When the dog 101 is inside the doghouse 119, the RF transceiver is in relatively close proximity to the RF transceiver 202 in the collar, and thus the RF transceiver 202 can be operated in low-power mode to conserve power in the collar 102.

[0184] FIG. 5 is a block diagram of the treat dispenser 122. In the dispenser 122, a first RF transceiver 502, a treat sensor 503, a low-supply sensor 510, and a gate 504 are provided to a processor 501. On command from the computer system 103, the processor 501 controls the gate 504 to release a treat (or medicine, vitamin, etc.) from a reservoir 508. The sensor 503 senses when the dog 101 has retrieved the treat. The low-supply sensor 510 senses when the supply of treats is running low. When the supply of treats is running low, the computer system 103 alerts the trainer or owner. In one embodiment, if the supply is not replenished, then the computer system changes its algorithm to reduce the number of treats given and thereby extend the supply of treats. An optional signaling device 511 (e.g., a light and/or audio output device) is also provided to the processor 501 to allow the computer system 103 to signal to the dog 101 that a treat is available. In multiple-dog environments, the sensor 505 includes a short-range RFID sensor to detect which dog retrieved the treat (or medicine, vitamin, etc.).

[0185] In one embodiment, the treat dispenser 112 is built into the animatronics trainer 123 so that the dog will perceive the animatronics trainer 123 as the source of the treats.

[0186] FIG. 8A is a diagram of the food dispenser 121, and FIG. 8B is a block diagram of the food dispenser 121. In the food dispenser 121, a first RF transceiver 802, a food bowl sensor 803, a low-supply sensor 810, and a gate 804 are provided to a processor 801. On command from the computer

system 103, the processor 801 controls the gate 804 to release food from a reservoir 808 into a bowl 820. The sensor 803 senses the amount of food in the bowl 820. As the dog 101 eats the food, the sensor 803 senses the lowered level of food in the bowl and the processor 801 reports the food consumption back to the computer system 103. The low-supply sensor 810 senses when the supply of food in the reservoir 808 is running low and reports the low-food condition back to the central processor 103. In multiple-dog environments, the sensor 803 includes a short-range RFID sensor to detect which dog retrieved the treat.

[0187] The food dispenser 121 allows the computer system 103 to track the dog's food consumption and consumption patterns (e.g., time of day, amount per feeding, etc.). The system 103 can count calories for the dog 101 make sure that the dog is not overeating or under-eating. In one embodiment, food is delivered in measured amounts at specified times.

[0188] In one embodiment, the sensor 803 includes a scale that is used to measure the amount of food that goes into and out of the bowl by measuring the weight of food into and out of the bowl.

[0189] In one embodiment, the food dispenser 121 can be configured to deliver different types of food for different dogs. (e.g., puppy food, diet food, old-dog food, etc.). The system 100 dispenses the proper type and amount of food depending on which dog is at the food dispenser.

[0190] FIG. 9 is a block diagram of the water dispenser 120. In the water dispenser 120, a first RF transceiver 902, a water level sensor 903, a water temperature sensor 913, a low-supply sensor 910, and a valve 904 are provided to a processor 901. On command from the computer system 103, the processor 901 controls the valve 904 to release water from a water supply 908 into a bowl 920. The water supply 908 can be a water reservoir, a plumbing connection, a garden hose connection, etc. In one embodiment, a pressure reducer is provided to reduce the pressure of the water supplied to the valve 904. The sensor 903 senses the amount of water in the bowl 920. As the dog 101 drinks the water, the sensor 903 senses the lowered level of water in the bowl and the processor 901 reports the water consumption back to the computer system 103. If the water supply 908 is provided by a reservoir, then a low-supply sensor 910 senses when the supply of water in the reservoir 908 is running low and reports the low-water condition back to the central processor 103. The temperature sensor 913 is used to detect the temperature of the water in the bowl 920. In multiple-dog environments, a short-range RFID sensor 914 is provided to detect which dog is drinking.

[0191] The water dispenser 120 allows the computer system 103 to track the dog's water consumption and consumption patterns (e.g., time of day, amount of water, etc.). The system 103 make sure that the dog is getting enough water and watch for patterns of high water consumption. If the temperature of the water in the bowl 920 (as measured by the temperature sensor 913) is too high, then the processor 901 can flush the bowl with fresh water (in the case of a plumbing connection) or send a message to the computer system 103 (in the case of a reservoir).

[0192] The food dispenser 121 and water dispenser 120 allow the owner/trainer to leave the dog unattended for a period of time. In one embodiment, the computer system 103 contacts the owner if the food dispenser 121 runs low on food, if the water dispenser 120 runs low on water, or if the computer 103 cannot make contact with the dispensers 120, 121. In one embodiment, the owner/trainer can specify the thresh-

old value for determining at what point the system 100 warns the owner of low food or water supplies. Thus, for example, if the owner is relatively close by (e.g., at work) the threshold can be set relatively low since the dog would not be without food or water for very long if the supply runs out. By contrast, if the owner is relatively far away (e.g., out of town) then the threshold can be set relatively high since the dog would potentially be without food or water for an extended time if the supply runs out.

[0193] FIG. 10 is a diagram of one embodiment of the dog toilet system 117 that includes an optional RFID sensor 1014, a refuse bin 1010, a urination sensor 1005, and a refuse sensor 1006 provided to a processor 1001. The dog toilet 117 tracks the dog's patterns and disposes of refuse. The short-range RFID sensor 1014 is used to distinguish between multiple dogs

[0194] In one embodiment, the computer system 103 uses the biometric data available from the RFID tag 310, the water consumption data from the water dispenser 120, the food consumption data from the food dispenser 121, and/or the data from the dog toilet 117 to monitor the health and well being of the dog 101 on a real-time basis and on a long-term basis. Since the system 100 can be configured in a flexible manner (e.g., the owner/trainer may or may not have included the water dispenser 120, the food dispenser 121, etc.) different configurations of the system 100 will have different data available. The system 100 uses whatever data is available in making the health and welfare determinations. Thus for example, if the system 100 only has data from the collar 102, then the health and well-being information will be based on the information from the collar 102. As more capability is added to the system 100 (e.g., the owner/trainer adds additional monitoring capabilities) then the system 100 expands the analysis of health and well-being to use the additional data when appropriate. The computer system 103 can collect long-term behavior on the dogs 101 and produce plots and charts for the owner/trainer to allow for long-term health monitoring. Moreover, the computer system 103 can watch for changes in the long-term trends that could indicate health problems. Thus, for example, if the dog 101 is normally active at various times throughout the day and suddenly becomes inexplicably inactive, the computer 103 would inform the owner/trainer that the dog may be sick. In another example, if the food or water consumption patterns of the dog 101 changes significantly, then the system 100 can inform the owner/trainer.

[0195] In one embodiment, the compute system 103 keeps data concerning the calories consumed by the dog. In one embodiment, the compute system 103 keeps data concerning the number and types of corrective treatments given to the dog and the reasons therefore (e.g., what the dog was doing that caused the system to give a corrective treatment). In one embodiment, the compute system 103 keeps data concerning the number of and types of positive reinforcements given to the dog and the reasons therefore. In one embodiment, the compute system 103 keeps data concerning the amount of time the dog spends training, playing, sleeping, etc. In one embodiment, the system 100 keeps data concerning dog barking (when, how long, how loud, etc.). The system 100 can produce plots and charts of barking behavior to help the owner/trainer in breaking the dog of barking behavior. In one embodiment, the system 100 can be instructed to contact the

owner/trainer when the dog is barking. The owner can remotely talk to the dog (e.g., through the telephone) and try to quiet the dog.

[0196] In one embodiment, the system 100 uses ambient weather information as part of the health and well-being analysis. For example, a modest increase in water consumption and a decrease in activity levels during hot weather is generally expected, whereas an increase in food consumption is generally expected during relatively cold weather. Thus, in one embodiment, the system 100 takes such weather-related consumption patterns into account when making decisions about reporting a change in consumption patterns.

[0197] In one embodiment, many of the sensors and dog interaction devices in the system 100 are configured as wireless devices. Wireless devices are generally easier to install since they do not require wiring to communicate with the computer system 103. Moreover, items, such as the toys 114-116 that are moveable are easier for the dog to play with if they do not have a wired connection back to the computer system 103. The use of wireless devices also allows easy expansion of the system 100 since new wireless devices can automatically identify themselves to the computer system 103, thus allowing many aspects of the system 100 to be auto-configured. For example, in one embodiment the treat dispenser 122 automatically identifies itself to the computer system 103, thus informing the system 103 that treats are available for training the dog. The system 103 uses training without treats from the dispenser 122 when the dispenser 122 is not provided, has run out of treats, or has run out of battery power. Conversely, the system 103 can use training with treats when the dispenser 122 is available, and has enough battery power and treats.

[0198] The sensors 129 can be configured as wired or wireless sensors and can include, for example, sensors to measure ambient conditions, such as, for example, smoke, temperature, moisture, wind velocity, precipitation, water, water temperature, humidity, carbon monoxide, natural gas, propane gas, security alarms, intrusion alarms (e.g., open doors, broken windows, open windows, and the like), other flammable gases, radon, poison gasses, etc. Different sensor units can be configured with different sensors or with combinations of sensors.

[0199] The wireless units of the system 100, such as, for example, the dispensers 120-122, the toys 114-116, the dog house 119, the collar 102, etc. each include a transceiver for wireless communication. These items communicate with the computer system 103 either directly through the RF base unit 104 or through one or more repeaters 113. The use of the repeaters 113 provides extended range and allows the various RF units to be dispersed throughout the house, yard, farm field, etc. In one embodiment, the repeaters are configured to be plugged into a wall outlet or otherwise provided with sufficient power. In one embodiment, one or more of the repeaters 113 are solar powered with batteries to provide operation during the night or on cloudy days. In one embodiment, the use of repeaters 113 allows the various RF units 102, 114-122 to operate at relatively lower power in order to conserve available power. In one embodiment, the transmit power of the transceivers in the RF units 102, 114-122 is adjustable, and the transmit power of each transceiver is reduced to that sufficient to provide relatively reliable communication with at least one repeater 113 (or the base unit 104). In one embodiment, the RF units 102, 114-122 use a two-way handshaking communication with the base unit 104

wherein messages set to the base unit **104** are acknowledged by the base unit **104** and messages sent by the base unit **104** to the RF units **102**, **114-122** are acknowledged by the respective RF units. The use of handshaking acknowledgement that a message has been received increases the reliability of the wireless communication system and often allows the wireless devices to operate at relatively lower power.

[0200] Each of the wireless units of the system **100**, such as, for example, the dispensers **120-122**, the toys **114-116**, the dog house **119**, the collar **102**, etc. includes a wireless communication transceiver **202** for communication with the base unit **104** (or repeater **113**). Thus, the discussion that follows generally refers to the collar **102** as an example, and not by way of limitation. Similarly, the discussion below generally refers to the base unit **104** by way of example, and not limitation. It will also be understood by one of ordinary skill in the art that repeaters **113** are useful for extending the range of the collar **102** but are not required in all configurations.

[0201] When the collar **102** detects a reportable condition (e.g., barking, choking, dog outside established boundaries, dog temperature too high or too low, dog moving through a doorway, etc.) the collar **102** communicates with the repeater unit **113** and provides data regarding the occurrence. The repeater unit **113** forwards the data to the base unit **104**, and the base unit **104** forwards the information to the computer **103**. The computer **103** evaluates the data and takes appropriate action. If the computer **103** determines that the condition is an emergency, then the computer **103** contacts the owner/trainer through telephone communication, Internet, the remote **112**, the monitor **108**, the computer monitor, etc. If the computer **103** determines that the situation warrants reporting, but is not an emergency, then the computer **103** logs the data for later reporting to the owner/trainer when the owner/trainer requests a status report from the computer **103**.

[0202] In one embodiment, the collar **102** has an internal power source (e.g., battery, solar cell, fuel cell, etc.). In order to conserve power, the collar **102** is normally placed in a low-power mode. In one embodiment, using sensors that require relatively little power, while in the low power mode the collar **102** takes regular sensor readings and evaluates the readings to determine if a condition exists that requires data to be transmitted to the central computer **103** (hereinafter referred to as an anomalous condition). In one embodiment, using sensors that require relatively more power, while in the low power mode the collar **102** takes and evaluates sensor readings at periodic intervals. Such sensor readings can include, for example, sound samples from the microphone **204**, location readings from the location sensors **301**, **302**, **303**, and/or **304**, physiological readings from the RFID tag **310**, etc.) If an anomalous condition is detected, then the collar **102** “wakes up” and begins communicating with the base unit **104** through the repeater **113**. At programmed intervals, the collar **102** also “wakes up” and sends status information (e.g., power levels, self diagnostic information, etc.) to the base unit **104** and then listens for commands for a period of time. In one embodiment, the collar **102** also includes a tamper detector. When tampering with the collar **102** is detected (e.g., someone has removed the collar **102** or the dog has somehow gotten out of the collar **102**, etc.), the collar **102** reports such tampering to the base unit **104**.

[0203] In one embodiment, the collar **102** provides bi-directional communication and is configured to receive data and/or instructions from the base unit **104**. Thus, for example, the base unit **104** can instruct the collar **102** to perform addi-

tional measurements, to go to a standby mode, to wake up, to report battery status, to change wake-up interval, to run self-diagnostics and report results, etc. In one embodiment, the collar **102** reports its general health and status on a regular basis (e.g., results of self-diagnostics, battery health, etc.). The computer system **103** can also program instructions into the collar **102**, such as, for example, the boundary areas for the dog, the allowable physiological parameters for the dog (e.g., the “normal” temperature range, etc.). If the sensors in the collar **102** later detect that a sensed condition is out of range (e.g., dog is out of boundary area, temperature is too high, etc.) then the collar will communicate the out-of-range information to the computer system **103**. In one embodiment, the computer system **103** can also program the operating parameters of the collar **102**, such as, for example, the sleep period between sensor measurements, the power level for the transmitter, the code used for spread spectrum transmissions, etc. In one embodiment, the computer system **103** can also program various signal processing information into the collar **102**, such as, for example, the coefficients and/or algorithms used to recognize the dog’s vocalizations (e.g., barking, whimpering, cries of pain, choking, etc.).

[0204] In one embodiment, the collar **102** samples, digitizes, and stores audio data from the microphone **204** when such data exceeds a volume threshold and/or when other sensors indicate that the audio data should be digitized and stored. For example, choking sounds are often not very loud, but are often accompanied by distinctive head movements. In one embodiment, the collar **102** digitizes audio data from the microphone when the IMU **303** detects head movements that are suggestive of choking, gagging, regurgitating, etc. In one embodiment, the collar **102**, having less processing power than the computer system **103**, transmits the sampled audio data and related IMU data to the computer **103** for further processing. In one embodiment, the collar **102** performs initial threshold tests on the audio data **102** to determine if the character of the audio data and/or IMU data justify the use of available power in the collar to transmit the data to the computer system **103**. If the collar **102** determines that the digitized audio data is relatively unlikely to be important, then the collar **102** can save power by not transmitting the data to the computer **103**.

[0205] In one embodiment, the computer system **103** can instruct the collar **102** to automatically apply a correction (e.g., vibration, shock, unpleasant sound, unpleasant smell, etc.) to the dog if the collar **102** detects that the dog is barking. In one embodiment, the computer system **103** instruct the collar **102** to not automatically apply a correction to the dog if the collar **102** detects that the dog is barking, but rather to send a “dog is barking” message to the computer system **103** in order to allow the computer system **103** (or the owner/trainer) to make the decisions regarding correction. In one embodiment, the computer system **103** instruct the collar **102** to automatically apply a particular correction to the dog if the collar **102** detects that the dog is barking and to send a “correction applied” message to the computer system **103** in order to allow the computer system **103** to keep track of the corrections that have been applied. If the computer system **103** deems that more severe correction is warranted, then the computer **103** sends a new command to the collar **102** to change the type or severity of the correction. In one embodiment, the computer system **103** sends a “good dog” message to the dog (through the speaker **206**) when the dog stops barking.

[0206] In one embodiment, the collar 102 provides two wake-up modes, a first wake-up mode for taking sensor measurements (and reporting such measurements if deemed necessary), and a second wake-up mode for listening for commands from the central computer 103. The two wake-up modes, or combinations thereof, can occur at different intervals.

[0207] In one embodiment, the collar 102 use spread-spectrum techniques to communicate with the repeater unit 113. In one embodiment, the collar 102 uses Code Division Multiple Access (CDMA) techniques. In one embodiment, the collar 102 uses frequency-hopping spread-spectrum. In one embodiment, the collar 102 has an address or identification (ID) code that distinguishes the collar 102 from the other RF units of the system 100. The collar 102 attaches its ID to outgoing communication packets so that transmissions from the collar 102 can be identified by the repeater 113. The repeater 113 attaches the ID of the collar 102 to data and/or instructions that are transmitted to the collar 102. In one embodiment, the collar 102 ignores data and/or instructions that are addressed to other RF units.

[0208] In one embodiment, the collar 102 includes a reset function. In one embodiment, the reset function is activated by a reset switch on the collar 102. In one embodiment, the reset function is activated when power is applied to the collar 102. In one embodiment, the reset function is activated when the collar 102 is connected to the computer system 103 by a wired connection for programming. In one embodiment, the reset function is active for a prescribed interval of time. During the reset interval, the transceiver 202 is in a receiving mode and can receive the identification code from the computer 103. In one embodiment, the computer 103 wirelessly transmits a desired identification code. In one embodiment, the identification code is programmed by connecting the collar 102 to the computer through an electrical connector, such as, for example, a USB connection, a firewire connection, etc. In one embodiment, the electrical connection to the collar 102 is provided by sending modulated control signals (power line carrier signals) through a connector used to connect the power source 203. In one embodiment, the external programmer provides power and control signals.

[0209] In one embodiment, the collar 102 communicates with the repeater 113 on the 900 MHz band. This band provides good transmission through walls and other obstacles normally found in and around a building structure. In one embodiment, the collar 102 communicates with the repeater 113 on bands above and/or below the 900 MHz band. In one embodiment, the collar 102, repeater 113, and/or base unit 104 listen to a radio frequency channel before transmitting on that channel or before beginning transmission. If the channel is in use, (e.g., by another device such as another repeater, a cordless telephone, etc.) then the sensor, repeater, and/or base unit changes to a different channel. In one embodiment, the collar 102, repeater, and/or base unit coordinate frequency hopping by listening to radio frequency channels for interference and using an algorithm to select a next channel for transmission that avoids the interference. Thus, for example, in one embodiment, if the collar 102 senses a dangerous condition (e.g., the dog 101 is choking or crying in pain) and goes into a continuous transmission mode, the collar 102 tests (e.g., listens to) the channel before transmission to avoid channels that are blocked, in use, or jammed. In one embodiment, the collar 102 continues to transmit data until it receives an acknowledgement from the base unit 104 that the message

has been received. In one embodiment, the collar transmits data having a normal priority (e.g., status information) and does not look for an acknowledgement, and the collar transmits data having elevated priority until an acknowledgement is received.

[0210] The repeater unit 113 is configured to relay communications traffic between the collar 102 and the base unit 104. The repeater unit 113 typically operates in an environment with several other repeater units. In one embodiment, the repeater 113 has an internal power source (e.g., battery, solar cell, fuel cell, etc.). In one embodiment, the repeater 113 is provided to household electric power. In one embodiment, the repeater unit 113 goes to a low-power mode when it is not transmitting or expecting to transmit. In one embodiment, the repeater 113 uses spread-spectrum techniques to communicate with the base unit 104 and with the collar 102. In one embodiment, the repeater 113 uses frequency-hopping spread-spectrum to communicate with the base unit 104 and the collar 102. In one embodiment, the repeater unit 113 has an address or identification (ID) code and the repeater unit 113 attaches its address to outgoing communication packets that originate in the repeater (that is, packets that are not being forwarded).

[0211] In one embodiment, the base unit 104 communicates with the collar 102 by transmitting a communication packet addressed to the collar unit 102. The repeaters 113 receive the communication packet addressed to the collar unit 102. The repeaters 113 transmit the communication packet addressed to the collar 102 to the collar unit 102. In one embodiment, the collar unit 102, the repeater units 113, and the base unit 104 communicate using Frequency-Hopping Spread Spectrum (FHSS), also known as channel-hopping.

[0212] Frequency-hopping wireless systems offer the advantage of avoiding other interfering signals and avoiding collisions. Moreover, there are regulatory advantages given to systems that do not transmit continuously at one frequency. Channel-hopping transmitters change frequencies after a period of continuous transmission, or when interference is encountered. These systems may have higher transmit power and relaxed limitations on in-band spurs. FCC regulations limit transmission time on one channel to 1200 milliseconds (averaged over a period of time 10-20 seconds depending on channel bandwidth) before the transmitter must change frequency. There is a minimum frequency step when changing channels to resume transmission.

[0213] In one embodiment, the collar unit 102, the repeater unit 110, and the base unit 104 communicate using FHSS wherein the frequency hopping of the collar unit 102, the repeater unit 110, and the base unit 104 are not synchronized such that at any given moment, the collar 102 and the repeater unit 113 are on different channels. In such a system, the base unit 104 communicates with the collar 102 using the hop frequencies synchronized to the repeater unit 113 rather than the collar unit 102. The repeater unit 113 then forwards the data to the collar unit using hop frequencies synchronized to the collar unit 102. Such a system largely avoids collisions between the transmissions by the base unit 104 and the repeater unit 110.

[0214] In one embodiment, the RF units 102, 114-122 use FHSS and are not synchronized. Thus, at any given moment, it is unlikely that any two or more of the units 102, 114-122 will transmit on the same frequency. In this manner, collisions are largely avoided. In one embodiment, collisions are not detected but are tolerated by the system 100. If a collision

does occur, data lost due to the collision is effectively re-transmitted the next time the collar units transmit collar data. When the units **102**, **114-122** and repeater units **113** operate in asynchronous mode, then a second collision is highly unlikely because the units causing the collisions have hopped to different channels. In one embodiment, the unit **102**, **114-122**, repeater units **113**, and the base unit **104** use the same hop rate. In one embodiment, the units **102**, **114-122**, repeater units **113**, and the base unit **104** use the same pseudo-random algorithm to control channel hopping, but with different starting seeds. In one embodiment, the starting seed for the hop algorithm is calculated from the ID of the units **102**, **114-122**, repeater units **113**, or the base unit **104**.

[0215] In an alternative embodiment, the base unit **104** communicates with the collar **102** by sending a communication packet addressed to the repeater unit **113**, where the packet sent to the repeater unit **113** includes the address of the collar unit **102**. The repeater unit **113** extracts the address of the collar **102** from the packet and creates and transmits a packet addressed to the collar unit **102**.

[0216] In one embodiment, the repeater unit **113** is configured to provide bi-directional communication between the collar **102** and the base unit **104**. In one embodiment, the repeater **113** is configured to receive instructions from the base unit **104**. Thus, for example, the base unit **104** can instruct the repeater to: send commands to the collar **102**; go to standby mode; “wake up”; report power status; change wake-up interval; run self-diagnostics and report results; etc.

[0217] The base unit **104** is configured to receive measured collar data from a number of RF units either directly, or through the repeaters **113**. The base unit **104** also sends commands to the repeater units **113** and/or to the collar **102**. When the base unit **104** receives data from the collar **102** indicating that there may be an emergency condition (e.g., the dog is in distress) the computer **103** will attempt to notify the owner/trainer.

[0218] In one embodiment, the computer **104** maintains a database of the health, power status (e.g., battery charge), and current operating status of all of the RF units **102**, **114-122** and the repeater units **113**. In one embodiment, the computer **103** automatically performs routine maintenance by sending commands to each unit **102**, **114-122** to run a self-diagnostic and report the results. The computer **103** collects and logs such diagnostic results. In one embodiment, the computer **103** sends instructions to each RF unit **102**, **114-122** telling the unit how long to wait between “wake-up” intervals. In one embodiment, the computer **103** schedules different wakeup intervals to different RF units based on the unit’s health, power status, location, usage etc. In one embodiment, the computer **103** schedules different wakeup intervals to different collar units based on the type of data and urgency of the data collected by the unit (e.g., the collar **102** has higher priority than the water unit **120** and should be checked relatively more often). In one embodiment, the base unit **104** sends instructions to repeaters **113** to route collar information around a failed repeater **113**.

[0219] In one embodiment, the computer **103** produces a display that tells the owner/trainer which RF units need repair or maintenance. In one embodiment, the computer **103** maintains a list showing the status and/or location of each dog **101** according to the ID of each collar. In one embodiment, the ID of the collar **102** is obtained from the RFID chip embedded in the dog **101**. In one embodiment, the ID of the collar **102** is programmed into the collar by the computer system **103**. In

one embodiment, the ID of the collar **102** is programmed into the collar at the factory such that each collar has a unique ID.

[0220] In one embodiment, the collar **102** and/or the repeater units **113** measure the signal strength of the wireless signals received (e.g., the collar **102** measures the signal strength of the signals received from the repeater unit **113**, the repeater unit **113** measures the signal strength received from the collar **102** and/or the base unit **104**). The collar unit **102** and/or the repeater units **113** report such signal strength measurement back to the computer **103**. The computer **103** evaluates the signal strength measurements to ascertain the health and robustness of the RF units of the system **100**. In one embodiment, the computer **103** uses the signal strength information to re-route wireless communications traffic in the system **100**. Thus, for example, if the repeater unit **113** goes offline or is having difficulty communicating with the collar unit **102**, the computer **103** can send instructions to a different repeater unit

[0221] In the collar **102**, the controller **202** typically provides power, data, and control information to the transceiver **201**. A power source **203** is provided to the controller **201**. An optional tamper sensor (not shown) is also provided to the controller **201**. A reset device (e.g., a switch) is provided to the controller **201**.

[0222] In one embodiment, the transceiver **202** is based on a TRF 6901 transceiver chip from Texas Instruments, Inc. In one embodiment, the controller **201** is a conventional programmable microcontroller. In one embodiment, the controller **201** is based on a Field Programmable Gate Array (FPGA), such as, for example, provided by Xilinx Corp. In one embodiment, the collar **201** includes a smoke detector. In one embodiment, the collar **102** includes a temperature sensor to measure ambient temperature. In one embodiment the collar **102** includes a water sensor.

[0223] The controller **202** receives collar data from the sensors and systems in the collar **102**. The collar **102** generally conserves power by not transmitting sensor data that falls within a normal range unless the collar **102** is being interrogated by the compute system **103**. In one embodiment, the controller **202** evaluates sensor data by comparing the data value to a threshold value (e.g., a high threshold, a low threshold, or a high-low threshold). If the data is outside the threshold (e.g., above a high threshold, below a low threshold, outside an inner range threshold, or inside an outer range threshold), then the data is deemed to be anomalous and is transmitted to the base unit **104**. In one embodiment, the data threshold is programmed into the controller **202**. In one embodiment, the data threshold is programmed by the base unit **104** by sending instructions to the controller **202**. In one embodiment, the controller **202** obtains collar data and transmits the data when commanded by the computer **103**.

[0224] In one embodiment, a tamper sensor **1105** is configured as a switch that detects removal of or tampering with the collar unit **102**.

[0225] FIG. **11** is a block diagram of the repeater unit **113**. In the repeater unit **113**, a first transceiver **1102** and a second transceiver **1105** are provided to a controller **1103**. The controller **1103** typically provides power, data, and control information to the transceivers **1102**, **1104**. A power source **1106** is provided to the controller **1103**.

[0226] When relaying collar data to the base unit **104**, the controller **1103** receives data from the first transceiver **1103** and provides the data to the second transceiver **1104**. When relaying instructions from the base unit **104** to a collar unit,

the controller **1103** receives data from the second transceiver **1104** and provides the data to the first transceiver **1102**. In one embodiment, the controller **1103** conserves power by placing the transceivers **1102**, **1104** in a low-power mode during periods when the controller **1103** is not expecting data. The controller **1103** also monitors the power source **1106** and provides status information, such as, for example, self-diagnostic information and/or information about the health of the power source **1106**, to the base unit **104**. In one embodiment, the controller **1103** sends status information to the base unit **104** at regular intervals. In one embodiment, the controller **1103** sends status information to the base unit **104** when requested by the base unit **104**. In one embodiment, the controller **1103** sends status information to the base unit **104** when a fault condition (e.g., battery low, power failure, etc.) is detected.

[0227] FIG. 12 is a block diagram of the base unit **104**. In the base unit **104**, a transceiver **1202** and a computer interface **1204** are provided to a controller **1203**. The controller **1103** typically provides data and control information to the transceivers **1202** and to the interface. The interface **1202** is provided to a port on the monitoring computer **103**. The interface **1202** can be a standard computer data interface, such as, for example, Ethernet, wireless Ethernet, firewire port, Universal Serial Bus (USB) port, bluetooth, etc.

[0228] In one embodiment, the owner/trainer selects a dog breed for the dog **101** from a list of breeds provided by the computer **103**. The computer **103** adjusts the training environment based on the dog breed. Thus, for example, an active dog such as a border collie will receive relatively more training and/or play than a relatively less active dog breed. In one embodiment, the owner/trainer inputs the dog's age, sex, and general health into the computer **103** to allow the computer **103** to adjust the type of training, length of training etc. In one embodiment, the system **103** maintains records of the dogs health (e.g., temperature, heart rate, food consumption, etc.), training patterns and training progress. The computer system **103** can produce plots and graphs showing the dogs progress, comparing the progress of the dog **101** to other dogs, to the dog's progress from previous time periods, (e.g., months, years, etc.). In one embodiment, the computer system **103** evaluates the dog's health and training progress and makes suggestions to the owner/trainer. In one embodiment, the computer system **103** provides answers to questions selected by the owner/trainer from a list of questions and adjusts such answers based on the health and training history of the dog **101**. In one embodiment, the computer system **103** forwards to dog's data (e.g. health data, training data, etc.) to a remote trainer who can then give feedback to the dog's owner/trainer. Thus, for example, if the dog **101** is exhibiting destructive behavior the owner/trainer can ask the computer **103** (or, optionally, a remote trainer) for recommendations to cure such behavior and the computer **103** can make recommendations based on the dog's breed, age, training history, etc. If the dog **101** is exhibiting poor training progress the owner/trainer can ask the computer **103** (or, optionally, a remote trainer) for recommendations to cure such behavior and the computer **103** can make recommendations based on the dog's breed, age, training history, etc. If the dog **101** is exhibiting potential health problems, the owner/trainer can ask the computer **103** (or, optionally, a remote veterinarian) for recommendations.

[0229] It is well known that most dogs prefer to keep to a relatively fixed daily schedule. The training system **100** is

better adapted to maintaining a fixed daily routine than a working owner/trainer who has other responsibilities. Thus, for example, the system **100** can feed the dog prescribed amounts of food at prescribed times of day. The system **100** can play with the dog at prescribed times of day. The system **100** can train the dog at prescribed times of day and allow the dog in or out of the house at prescribed times. After an initial adjustment period, the dog **101** will adjust to the schedule provided by the system **100** and will in general be happier and healthier than a dog that must adjust to an owner's varying schedule. The dog **101** also benefits from the impartiality of the training and management system **100**. Unlike an owner/trainer, the system **100** will not get mad at the dog and punish the dog out of anger. In one embodiment, the system **100** provides better training than a typical owner or trainer because the system **100** is provided with a training program designed by an expert. Thus, the system **100** is less likely to punish the dog **101** in a situation where the dog does not understand the reason for the punishment. Moreover, the system **100**, is relatively more likely to reward the dog in such a way that the dog understands the reason for the reward and will make the connection between desired behavior and the reward. For example, many untrained owners do not understand that reward should generally occur immediately so that the dog will properly associate action with reward. The system **100** has a relatively high-quality training program built-in and thus alleviates the need for an owner to buy books to study and learn proper dog training methods. In one embodiment, a professional trainer works with the dog **101** for a relatively short period of time in order to get the dog accustomed to the system **100**, and then the dog **101** can work with the system **100** for extended periods without supervision.

[0230] In one embodiment, a remote trainer can use the Internet or telephone modem to connect to the computer system **103** and remotely train the dog or provide other interaction with the dog.

[0231] FIG. 13 is a block diagram of a ball tossing unit **1300** used to play "fetch" with the dog. The ball tossing unit **1300** includes a processor **1301** and (optional) RF unit **1302**, a ball launcher **1304**, a ball sensor **1305**, and optionally, a light or sound device **1306**. The ball tossing unit **1300** uses the ball launcher **1304** to launch a ball for the dog to fetch. When the dog fetches the ball and drops in a basket or other receptacle in the ball tossing unit **1300**, the ball sensor detects the fetched ball **1305**. In one embodiment, the ball tossing unit is operated by command from the computer system **103**. In one embodiment, the ball tossing unit is operated according to a timer such that the unit plays fetch with the dog at prescribed periods.

[0232] FIG. 14 is a architectural-type drawing of the floor plan of a portion of a house showing examples of placement of locations sensors to sense the movement of the dog around the house. In FIG. 14, relatively short-range sensors are placed in doorways or key passageways (e.g., halls, stairs, etc.) to track the general movement of the dog through the house. Location system units **1420-1423** are placed in or near doorways, and a location system unit **1424** is placed in a stairway.

[0233] In one embodiment, the location system units **1420-1423** are (or include) relatively short-range RFID readers that read the passage of the dog's RFID tag as the dog passes by the reader when going through the doorway, hallway, etc. in which the reader is located. The RFID reader reports the movement back to the computer system **103** which keeps a

record of the dog's movements and current whereabouts. As with the dog house 119, in one embodiment, the location system units 1420-1424 can perform many of the functions of the collar 102 such as, for example, reading biometric data from the RFID tag 310. In one embodiment, the collar 102 is omitted or can be removed from the dog 101 while the dog 101 is in the house. In one embodiment, location system units 1410-1412 are placed relatively high in the room (e.g., on the ceiling) to provide a view of the various rooms of the house.

[0234] In one embodiment, the location system units 1420-1424 or 1410-1412 are (or include) infrared sensors that communicate with the infrared system 301 in the collar 102 to provide relatively short-range relatively line-of sight communication for tracking the movements of the dog. As the dog passes the location system units 1420-1424 or 1410-1412, the sensor communicates with the collar 102 to note the passage of the dog and the information is then transmitted back to the computer 103 either by the collar 102 or the location system units 1420-1424 or 1410-1412. In one embodiment, the location system units 1420-1424 or 1410-1412 also operate as motion detectors for a home security system.

[0235] In one embodiment, the location system units 1420-1424 or 1410-1412 are (or include) acoustic sensors that communicate with the acoustic systems in the collar 102 to provide relatively short-range relatively line-of sight communication for tracking the movements of the dog. As the dog passes the location system units 1420-1424 or 1410-1412, the sensor communicates with the collar 102 to note the passage of the dog and the information is then transmitted back to the computer 103 either by the collar 102 or the location system units 1420-1424 or 1410-1412. In one embodiment, the location system units 1420-1424 or 1410-1412 also operate as motion detectors for a home security system.

[0236] In one embodiment, the location system units 1420-1424 or 1410-1412 are (or include) relatively low-power microwave transmitters or receivers that communicate with the RF system 304 in the collar 102 to provide relatively short-range relatively line-of sight communication for tracking the movements of the dog. As the dog passes the location system units 1420-1424 or 1410-1412, the sensor communicates with the collar 102 to note the passage of the dog and the information is then transmitted back to the computer 103 either by the collar 102 or the location system units 1420-1424 or 1410-1412.

[0237] In one embodiment, the computer system 103 is provided with a map of the house and shows the location of the dog with respect to the map.

[0238] In one embodiment, the system 100 determines when the dog is sleeping by monitoring the dogs movement and temperature.

[0239] In one embodiment one or more of the radio frequency aspects of the system 100 use a frequency band between 800 and 1100 MHz for general communications. In one embodiment, one or more of the radio frequency aspects

of the system 100 use frequencies below 800 MHz for emergency or longer-range communication. In one embodiment, the frequency capabilities of the transceivers in the collar 102 are adjustable, and the base unit 104 and collar 102 select are configured to use communication frequencies that conserve power while still providing adequate communications reliability. In one embodiment, one or more of the radio frequency aspects of the system 100 use frequencies above 1100 MHz for relatively short-range communication (e.g. communication within a room). In one embodiment, the base unit 104 and/or one or more of the repeaters 113 includes a direction finding antenna for determining a direction of the radiation received from the collar 102. In one embodiment, the base unit 104 and/or one or more of the repeaters 113 includes an adaptive antenna for increasing antenna gain in the direction of the collar 102. In one embodiment, the base unit 104 and/or one or more of the repeaters 113 includes an adaptive antenna for canceling interfering noise.

[0240] In one embodiment, the collar 102 includes radio frequency, acoustic and infrared communications capabilities. In one embodiment, the system 100 communicates with the collar 102 using radio frequency, acoustic or infrared communication depending on the situation, e.g., acoustic, infrared, or relatively higher frequency radio frequencies for relatively shorter range communication and relatively lower frequency radio frequencies for relatively longer range communications.

[0241] Although various embodiments have been described above, other embodiments will be within the skill of one of ordinary skill in the art. Thus, although described in terms of a dog, such description was for sake of convenience and not by way of limitation. One of ordinary skill in the art will recognize that all or part of the system 100 can be applied to other animals, such as, for example, cats, livestock, zoo animals, farm animals, etc. Thus, the invention is limited only by the claims that follow.

What is claimed is:

1. A method for monitoring condition of a pet, comprising; sensing a measured amount of water consumed by the pet; providing a measured amount to a computer system; comparing said measured amount to an expected amount of water that the pet is expected to consume; and sending a warning message when said measured amount differs from said expected amount by more than an acceptable difference over a specified time period.
2. The method of claim 1, further comprising measuring one or more ambient conditions.
3. The method of claim 1, further comprising measuring one or more ambient conditions and adjusting said expected amount based, at least in part, on said ambient conditions.
4. The method of claim 1, wherein said warning is sent when said measured amount falls below said expected amount according to said acceptable difference.

* * * * *