

19



**Octrooi Centrum
Nederland**

11

2014158

12 B1 OCTROOI

21

Aanvraagnummer: **2014158**

51

Int. Cl.:
**B65B 23/06 (2015.01) B65G 47/38 (2015.01) B65G
47/54 (2015.01)**

22

Aanvraag ingediend: **19/01/2015**

43

Aanvraag gepubliceerd:
08/12/2016

73

Octrooihouder(s):
**Sanovo Technology Netherlands B.V.
te Aalten.**

47

Octrooi verleend:
05/01/2017

72

Uitvinder(s):
**Jan Hordijk te Aalten.
Edwin Lambertus Maria Papen te Vorden.**

45

Octrooischrift uitgegeven:
16/03/2017

74

Gemachtigde:
ir. H.V. Mertens c.s. te Rijswijk.

54

Egg transfer device.

57

An egg conveyor assembly comprises a first conveyor comprising at least one lane of egg retainers that extends in a first conveyor direction (X) on a first height level. A second conveyor comprises at least one lane of egg retainers that extends in a second conveyor direction (Y) on a second height level. A transfer device adapted to transfer eggs from the first conveyor to the second conveyor comprises an array of egg retainers. The first conveyor and second conveyor cross each other, wherein the first height level is above the second height level. The egg retainers of the transfer device comprise pockets having a receiving opening at an upper end thereof to receive the eggs from above from the first conveyor, and are adapted to release the eggs at a lower end to drop the eggs in the egg retainers of the second conveyor. The transfer device is movable in the first conveyor direction (X) and in the second conveyor direction (Y) in a plane on a height level between the first height level and second height level.

Title: Egg transfer device

5 The present invention relates to an egg conveyor assembly comprising:

- a first (endless) conveyor comprising at least one lane of egg retainers that extends in a first conveyor direction (X) on a first height level,

- a second (endless) conveyor comprising at least one lane of egg retainers that extends in a second conveyor direction (Y) on a second height level, wherein the first

10 conveyor direction (X) and second conveyor direction (Y) are substantially perpendicular, and

- a transfer device adapted to transfer eggs from the first conveyor to the second conveyor and comprising an array of egg retainers, said array having at least one row of egg retainers, wherein each row has a number of egg retainers that corresponds to the number of lanes of the first conveyor, and which array furthermore has a number of rows that

15 corresponds to the number of lanes of the second conveyor.

US 3.894.631 discloses an egg conveyor assembly having a first endless conveyor with six lanes, wherein the eggs are oriented horizontally and supported on rollers and a second conveyor with one lane of egg retaining pockets for carrying the eggs oriented vertically. An egg transfer mechanism is provided at the discharge end of the first conveyor.

20 The transfer mechanism comprises six egg transfer cups and receives the eggs in the horizontal orientation in said cups and drops the eggs in the retaining pockets of the second conveyor. The transfer mechanism is adapted to tilt the cups to a downwardly inclined position and is adapted to accelerate the egg transfer cups to a velocity that approximates the velocity of the second conveyor.

25 In EP 2 174 896 A1 a different egg conveyor assembly is disclosed. In this known assembly a first conveyor and a second conveyor cross each other, wherein the second conveyor is positioned below the first conveyor. The first conveyor has rows of retaining seats and the second conveyor has retaining seats for receiving eggs from above and retain them. The pitch between the retaining seats of the first conveyor in the crosswise direction
30 can be changed. Subsequently the retaining seats of the first conveyor can be accelerated in the direction of movement of the second conveyor to synchronise their speed with the conveying speed of the second conveyor and the eggs are ejected from the retaining seats of the first conveyor directly into the retaining seats of the second conveyor. In this known egg conveyor assembly the retaining seats of the first conveyor retain a speed transverse to the
35 direction of the second conveyor when the transfer of eggs takes place. This has the disadvantage that the eggs that are dropped from the seats of the first conveyor into the seats of the second conveyor have a relative horizontal speed component. If the speed of the

first conveyor is increased the risk of damaging or loss of eggs is increased. This thus limits the speed of the first conveyor and consequently the capacity of the conveyor assembly.

The present invention has for an object to provide an alternative egg conveyor assembly.

5 This object is achieved by an egg conveyor assembly according to the preamble of claim 1, wherein the first conveyor and second conveyor cross each other, wherein the first height level is above the second height level,

the egg retainers of the transfer device comprise pockets having a receiving opening at an upper end thereof to receive the eggs from above from the first conveyor, and are
10 adapted to release the eggs at a lower end to drop the eggs in the egg retainers of the second conveyor, and

the transfer device is movable in the first conveyor direction (X) and in the second conveyor direction (Y) in a plane on a height level between the first height level and second height level.

15 With the configuration of the conveyor assembly according to the invention allows to achieve one or more of the following advantages:

The transfer device can be synchronised in speed with both the first conveyor and the second conveyor in the first conveyor direction (X) and in the second conveyor direction (Y) respectively, such that during the transfer of eggs from the first conveyor to the transfer
20 device and from the transfer device to the second conveyor the relative speed between the egg discharging part and the egg receiving part is approximately zero. Thereby the speed of the first conveyor can be higher than with existing conveyor assemblies with a transfer between conveyors known from the prior art.

Furthermore, the configuration of the conveyor assembly according to the invention
25 allows the use of gravity as the driving force for transferring the eggs from the first conveyor to the transfer device and from the transfer device to the second conveyor. For example no complex lifting structures have to be applied.

Moreover, due to the fact that the first conveyor and second conveyor cross each other at different height levels, there is less floor space necessary in the plant to transfer
30 eggs from the one to the other conveyor.

Also the feature that the egg retainers of the transfer device comprise pockets in which the eggs are received from above and are released at a lower end is favourable in that these pockets firmly hold the eggs all around and allow the eggs to be accelerated and decelerated at a high rate, without the risk that the eggs are lost from the retainers or
35 damaged. Thus a quickly moving transfer device can be provided, which results in that the possible speed and acceleration/deceleration that can be achieved by the transfer device does not form a too great limitation for the speed of the conveyors.

Also, because a separate transfer device is used between the first and second conveyor, relatively standard endless conveyors can be used as first and second conveyor which is economically favourable.

5 In a preferred embodiment the transfer device is adapted and arranged in such a way that the transfer device in a first stage of movement, in which the eggs are received from the first conveyor, moves in the first conveyor direction (X) with a velocity (v_x), preferably a constant velocity, synchronised with the first conveyor, and in a second stage of movement, in which the eggs are released to the second conveyor, moves in the second conveyor direction (Y) with a velocity (v_y), preferably a constant velocity, synchronised with the second
10 conveyor. The transfer device is thus advantageously moveable in the first conveyor direction X and in the second conveyor direction Y such that the eggs can be received by the transfer device from the first conveyor while its movement is synchronised with the movement of the first conveyor and such that the eggs can be discharged from the transfer device to the second device while the movement of the transfer device is synchronised with the movement
15 of the second conveyor. Thus the risk of damaging the eggs during transfer from the first conveyor to the transfer device and subsequently from the transfer device to the second conveyor is greatly reduced, while advantageously the first conveyor and second conveyor can continuously move on (possibly at high speed) without intermittently stopping and accelerating again.

20 In a further embodiment the transfer device is adapted and arranged in such a way that, in an intermediate stage between the first and second stages of movement, the transfer device is decelerated in the first direction (X) from a velocity (v_x) of the first conveyor to a velocity of preferably 0 m/s and is, preferably simultaneously, accelerated in the second direction from preferably a velocity of 0 m/s to the velocity (v_y) of the second conveyor.

25 In a possible embodiment the egg retainers of the first conveyor has egg retaining pockets adapted to release the eggs at a lower end to drop the eggs in the egg retainers of the transfer device. Egg retaining pockets of this type are as such known and are proven technology, which is advantageous to apply.

30 In a possible embodiment the egg retainers of the second conveyor comprise pockets having a receiving opening at an upper end thereof to receive the eggs from above. The pocket type retainers hold the eggs in an upright position, thereby providing a high capacity per length unit. Furthermore the pocket type egg retainers allow a fast conveying speed without the danger of losing or damaging the eggs. Thus the overall capacity of the conveyor assembly can be maintained high.

35 In a possible embodiment the assembly comprises one transfer device.

In another possible embodiment the assembly comprises at least two transfer devices, which are arranged such that when one of the at least two transfer devices is

transferring eggs from the first conveyor to the second conveyor, another one of the at least two transfer devices is in a return stage in which it moves back to the initial position at the first conveyor.

In a possible embodiment the first conveyor and second conveyor each have a drive mechanism comprising a drive motor, wherein the transfer device is coupled through a cam mechanism with the drive mechanism of the first conveyor or the second conveyor to drive the movement of the transfer device. The advantage of this is that the conveyors and the transfer can be mechanically coupled and mechanically synchronised, which provides a robust synchronising system which will not fail easily.

In a particularly practical embodiment the transfer device comprises an outer carrying frame and an inner carrying frame, the array of egg retainers being supported in the inner carrying frame, the inner carrying frame being moveable along a first guide that is provided on the outer carrier frame, and the outer carrying frame being supported by a fixed second guide, wherein the first guide and the second guide extend substantially perpendicular. Preferably the first guide extends parallel to the first conveyor direction (X) and the second guide extends parallel to the second conveyor direction (Y).

In a possible embodiment the array of egg retainers is removable from the assembly. This allows the array of egg retainers to be disassembled from the assembly which facilitates for example cleaning them or performing regular maintenance.

The invention will be elucidated in the following detailed description with reference to the drawing, in which:

Fig. 1 shows schematically a side view of a possible embodiment of a conveyor assembly according to the invention;

Fig. 2 shows a front view from the line II-II as indicated in Fig. 1;

Fig. 3 shows a detailed side view of the conveyor assembly of Fig. 1 at the location of the transfer mechanism;

Fig. 4 shows a view in perspective of a part of a transfer device of the conveyor assembly of Fig. 1;

Fig. 5 shows a front view of the transfer device of Fig. 4;

Fig. 6 shows a top elevational view of the transfer device of Fig. 4 together with an indication of velocity vectors applied during use;

Fig. 7 shows a side elevational view of the transfer device of Fig. 4 while receiving eggs from above;

Fig. 8 shows a side elevational view of the transfer device of Fig. 4 while holding the eggs;

Fig. 9 shows a side elevational view of the transfer device of Fig. 4 while releasing the eggs at an underside;

Fig. 10 shows a diagram in which the velocities of the transfer device in use in X and Y direction are plotted against time;

Fig. 11 shows a view in perspective of a second conveyor and a transfer device of another possible embodiment of a conveyor assembly according to the invention;

5 Fig. 12 shows a top elevational view of the second conveyor and transfer device of Fig. 11; and

Fig. 13 shows a side elevational view of the second conveyor and transfer device of Fig. 11.

10 Figs. 1 - 3 show a conveyor assembly comprising a first endless conveyor 1 which extends at a first height level and a second endless conveyor 2 which extends at a second height level below the first height level. The first conveyor 1 extends in a first direction X and the second conveyor extends in a second direction Y, which is substantially perpendicular to the first direction X. The first conveyor 1 and the second conveyor 2 cross each other.
15 Because the first conveyor 1 and second conveyor 2 cross each other at different height levels, floor space in the plant is used more efficiently. Moreover gravity can be conveniently used to transfer the eggs from the first conveyor 1 to the second conveyor 2.

The first endless conveyor 1 comprises a number of lanes of egg retainers. In the embodiment shown in Fig 1 – 3 by way of example, the first conveyor 1 has six lanes of egg
20 retainers. The egg retainers of the first conveyor 1 are configured as egg retaining pockets 10 adapted to release the eggs at a lower end 12 to drop the eggs in egg retaining pockets 6 of a transfer device 3 as is illustrated in Fig. 2. The egg retaining pockets 10 of the first conveyor 1 have a receiving opening 13 to receive the eggs 50 from above. The egg retaining pockets 10 have pivotable pocket fingers 11 which are adapted to pivot between a
25 holding position (cf. Fig 2 at the left) and a release position spaced apart from each other (cf. Fig. 2 in the middle) to create a passage at the lower end to release the eggs 50 at said lower end of the pockets 10.

The second endless conveyor 2 comprises a number of egg retainers. In the embodiment shown the second conveyor 2 has two lanes of egg retainers. The egg retainers
30 of the second conveyor 2 are configured as egg retaining pockets 21 having a receiving opening 23 at an upper end thereof to receive the eggs from above. The egg retaining pockets 21 have pivotable pocket fingers 22 which are adapted to pivot between a holding position (cf. Fig. 2) and a release position spaced apart from each other (not shown) to create a passage at the lower end to release the eggs 50 at said lower end of the pockets 21
35 into for example another egg handling station or into an egg package or tray.

Positioned in a plane on a height level between the first height level and second height level is a transfer device 3. The transfer device 3 comprises a frame 4 in which an

array 5 of pockets 6 is arranged as is shown in Fig. 4. In the embodiment shown, the array comprises two rows of each six pockets 6.

In Figs 7 - 9 is shown the transfer device 3 during receiving the eggs 50 (Fig. 7), during retaining the eggs 50 (Fig. 8) and during releasing the eggs 50 (Fig. 9). Also in Fig. 5 is shown the transfer device 3 during releasing the eggs 50, but from a different view. The pockets 6 of the transfer device have a receiving opening 7 at an upper end thereof to receive the eggs 50 from above from the first conveyor 1, as is also illustrated in Fig. 2. The pockets 6 have pivotable pocket fingers 61, similar to the pockets of the first conveyor, which are adapted to pivot away from each other (cf. Fig. 9) to release the eggs 50 at a lower end 8 to drop the eggs 50 in the egg retainers 21 of the second conveyor 2, as is also illustrated in Fig. 3.

The respective falling heights of the eggs 50 from the pockets 10 of the first conveyor 1 in the pockets 6 of the transfer device 3 and from the pockets 6 of the transfer device 3 in the pockets 21 of the second conveyor 2 in a practical embodiment may range of 80mm - 120mm, more in particular about 100mm.

The transfer device 3 is movable in the first conveyor direction X and in the second conveyor direction Y in a plane on the mentioned height level between the first height level and second height level. The array 5 of pockets 6 and the frame 4 of the transfer device 3 can move in such a way that the transfer device 3 in a first stage of movement, in which the eggs 50 are received from the first conveyor (cf. Fig. 2), moves in the first conveyor direction X with a constant velocity v_x synchronised with the first conveyor 1. In a second stage of movement, in which the eggs are released to the second conveyor 2 (cf. Fig. 3), the transfer device moves in the second conveyor direction Y with a constant velocity v_y synchronised with the second conveyor 2. The transfer device 3, in an intermediate stage between the first and second stages of movement, is decelerated in the first direction X from a velocity v_x of the first conveyor to a velocity of 0 m/s and is simultaneously accelerated in the second direction from a velocity of 0 m/s to the velocity v_y of the second conveyor. This is illustrated in Fig. 6 on the right where the velocity vectors are indicated.

Also in Fig. 10 is shown a plot of the velocities v_x and v_y of the transfer device 3 against time. It is noted that the indicated durations and velocities in Fig. 10 are given as an example, and is not to be considered as limiting or essential.

In a stage A (duration about 120ms) the velocity v_x is constant and synchronised with the velocity of the first conveyor 1. At the same time the velocity v_y is 0 m/s. During this stage A the eggs 50 are dropped from the pockets 11 of the first conveyor 1 in the pockets 6 of the transfer device 3.

In a stage B (duration about 55ms) the transfer device 3 is accelerated in the Y-direction and simultaneously decelerated in the X direction. Both the acceleration and deceleration are constant.

In a stage C (duration about 112ms) the velocity v_x is 0 m/s and the velocity v_y is constant and synchronised with the velocity of the second conveyor 2. During this stage C the eggs 50 are dropped from the pockets 6 from the transfer device 3 in the pockets 21 of the second conveyor 2.

In a stage D (duration about 64ms) the velocity v_y is decelerated to 0 m/s. simultaneously the transfer device 3 is accelerated in a direction opposite to the direction of movement of the first conveyor 1.

In a stage E (duration about 130ms) the transfer device 3 is in X-direction first decelerated to a velocity v_x of 0 m/s and then accelerated in the direction of movement of the first conveyor 1 until it is synchronised with the velocity of the first conveyor 1. At the same time the velocity v_y is first increased with constant acceleration in the direction opposite to the direction of movement of the second conveyor 2. Then (stage G) the velocity v_y of the transfer device 3 is decreased to 0 m/s. The transfer device 3 is now at the initial point of the movement at the beginning of stage A. Thus, in the example given, the total cycle of the transfer device takes about 0,5 second.

In Fig. 11 – 13 is disclosed an example of how the transfer device can be suspended and moved in the direction X and Y. In the embodiment illustrated the transfer device is indicated by reference numeral 103 and has an array of egg retaining pockets corresponding to a first conveyor (not shown in the Figs 11 - 13) having eighteen lanes and a second conveyor 102, schematically drawn having six lanes. A skilled person will understand that what is mentioned about the transfer device 3 in the above is also applicable to the transfer device 103 and, vice versa, what is mentioned here about the transfer device 103 is also applicable to the transfer device 3.

The transfer device 103 comprises an outer carrying frame 105 and an inner carrying frame 104. The array of egg retainers is carried by the inner carrying frame 104. The inner carrying frame 104 is moveable along a first guide 106 that is provided on the outer carrier frame 105. The outer carrying frame 105 is supported by a fixed second guide 107. The first guide 106 and the second guide 107 extend substantially perpendicular. The first guide 106 extends parallel to the first conveyor direction X. The second guide 107 extends parallel to the second conveyor direction Y.

The outer carrying frame 105 is connected through a push/pull rod 108 and a pivoting lever arm 109 to a drive mechanism to drive the movement of the outer carrying frame 105 along the second guide 107. When the lever arm 109 rotates clockwise around a horizontal shaft 110 in Fig. 13 the outer carrying frame 105 is pulled to the right in Fig. 13; when the

lever arm rotates anti-clockwise in Fig. 13, the outer carrying frame 105 is pushed to the left in Fig. 13.

The inner carrying frame 104 is connected by two rods 114A and 114B with respective lever arms 111 and 112 which can rotate around a vertical rotation axis 113. At 5 the other end of the lever arms 111, 112 they are interconnected by a push/pull rod 115. A further push/pull rod 116 is provided and connected to a pivoting lever arm 117, which pivots around the horizontal shaft 110, and the lever arm 112. Through this rod and lever mechanism the inner carrying frame 104 is connected with a drive mechanism to drive its movement.

10 In a particular preferred embodiment the described respective rod and lever mechanisms associated with the inner and outer carrying frames 104, 105 are connected with a drive mechanism of the first and/or second conveyor which comprises at least a drive motor. The advantage is that in this way the movement of the transfer device can be mechanically geared to the movement of one or both of the conveyors 1, 2. The transfer 15 device may for example be coupled through a cam mechanism with the drive mechanism of the first conveyor or the second conveyor to drive the movement of the transfer device.

CONCLUSIES

1. Eiertransportsamenstel omvattende:

- een eerste (eindeloze) transporteur omvattende ten minste een baan van
5 eierhouders

die zich in een eerste transporteurrichting (X) op een eerste hoogteniveau uitstrekt,

- een tweede (eindeloze) transporteur omvattende ten minste één baan van
eierhouders die zich in een tweede transporteurrichting (Y) op een tweede hoogteniveau
uitstrekt, waarbij de eerste transporteurrichting (X) en tweede transporteurrichting (Y) in

10 hoofdzaak loodrecht op elkaar staan, en

- een overdrachtsinrichting ingericht om eieren van de eerste transporteur naar de
tweede transporteur over te dragen en omvattende een matrix van eierhouders, waarbij de
matrix ten minste een rij van eierhouders heeft, waarbij elke rij een aantal eierhouders heeft
dat overeenkomt met het aantal banen van de eerste transporteur, en welke matrix verder
15 een aantal rijen heeft dat overeenkomt met het aantal banen van de tweede transporteur,
met het kenmerk, dat

de eerste transporteur en tweede transporteur elkaar kruisen, waarbij het eerste
hoogteniveau zich boven het tweede hoogteniveau bevindt,

20 de eierhouders van de overdrachtsinrichting buidels (pockets) omvat met een
opnameopening aan één bovenste einde ervan om de eieren van boven op te nemen vanaf
de eerste transporteur, en zijn ingericht om de eieren bij een onderste einde los te laten om
de eieren in de eierhouders van de tweede transporteur te laten vallen,

de overdrachtsinrichting beweegbaar is in de eerste transporteurrichting (X) en in de
tweede transporteurrichting (Y) in een vlak op een hoogteniveau tussen het eerste

25 hoogteniveau en het tweede hoogteniveau.

2. Eiertransporteursamenstel volgens conclusie 1, waarbij de overdrachtsinrichting
geschikt is en zodanig is ingericht dat de overdrachtsinrichting in een eerste bewegingsfase,
waarin de eieren worden opgenomen vanuit de eerste transporteur, in de eerste
transporteurrichting (X) beweegt met een snelheid (v_x) die is gesynchroniseerd met de
30 eerste transporteur, en in een tweede bewegingsfase, waarin de eieren worden losgelaten
na de tweede transporteur, in de tweede transporteurrichting (Y) beweegt met een snelheid
(v_y) die gesynchroniseerd is met de tweede transporteur.

3. Eiertransporteurinrichting volgens conclusie 2, waarbij de overdrachtsinrichting
geschikt is en zodanig is ingericht dat in een tussenfase tussen de eerste en tweede
35 bewegingsfases, de overdrachtsinrichting wordt vertraagd in de eerste richting (X) van een
snelheid (v_x) van de eerste transporteur naar een snelheid van bij voorkeur 0m/s en wordt

versneld in de tweede richting vanaf bij voorkeur een snelheid van 0m/s naar een snelheid (v_y) van de tweede transporteur.

4. Eiertransporteursamenstel volgens een van voorgaande conclusies, waarbij de eierhouders van de eerste transporteur eierhouderzakjes (pockets) zijn die geschikt zijn om de eieren aan een onderste einde los te laten om de eieren in de eierhouders van de overdrachtsinrichting te laten vallen.

5. Eiertransporteursamenstel volgens een van de voorgaande conclusies waarbij de eierhouders van de tweede transporteurbuidels (pockets) omvat met een opnameopening aan één bovenste einde ervan om de eieren van boven op te nemen.

6. Eiertransporteursamenstel volgens een van de voorgaande conclusies, waarbij het samenstel één overdrachtsinrichting omvat.

7. Eiertransporteursamenstel volgens een van de conclusies 1-5, waarbij het samenstel ten minste twee overdrachtsinrichtingen omvat, die zodanig zijn aangebracht dat wanneer een van de ten minste twee overdrachtsinrichtingen de eieren overdraagt van de eerste transporteur naar de tweede transporteur, en andere van de ten minste twee overdrachtsinrichtingen in een retourfase is waarin het terugbeweegt naar de beginpositie bij de eerste transporteur.

8. Eiertransporteursamenstel volgens een van de voorgaande conclusies, waarbij de eerste transporteur en tweede transporteur elk een aandrijfmotor omvattend een aandrijfmechanisme hebben, waarbij de overdrachtsinrichting via één nokkenmechanisme is gekoppeld met het aandrijfmechanisme van de eerste transporteur of de tweede transporteur om de beweging van de overdrachtsinrichting aan de drijven.

9. Eiertransporteursamenstel volgens een van de voorgaande conclusies, waarbij de overdrachtsinrichting een buitenste draagframe omvat alsmede een binnenste draagframe, waarbij de matrix van eierhouders is gedragen in het binnenste draagframe, waarbij het binnenste draagframe beweegbaar is langs een eerste geleiding die is voorzien op het buitenste draagframe, en waarbij het buitenste draagframe is gedragen door een vaste tweede geleiding, waarbij de eerste geleiding en de tweede geleiding zich in hoofdzaak loodrecht ten opzichte van elkaar uitstrekken.

10. Eiertransporteursamenstel volgens conclusie 9, waarbij de eerste geleiding zich evenwijdig aan de eerste transporteurrichting (X) uitstrekt en de tweede geleiding zich evenwijdig aan de tweede transporteurrichting (Y) uitstrekt.

11. Eiertransporteursamenstel volgens een van de voorgaande conclusies, waarbij de matrix van eierhouders uit het samenstel uitneembaar is om reiniging mogelijk te maken.

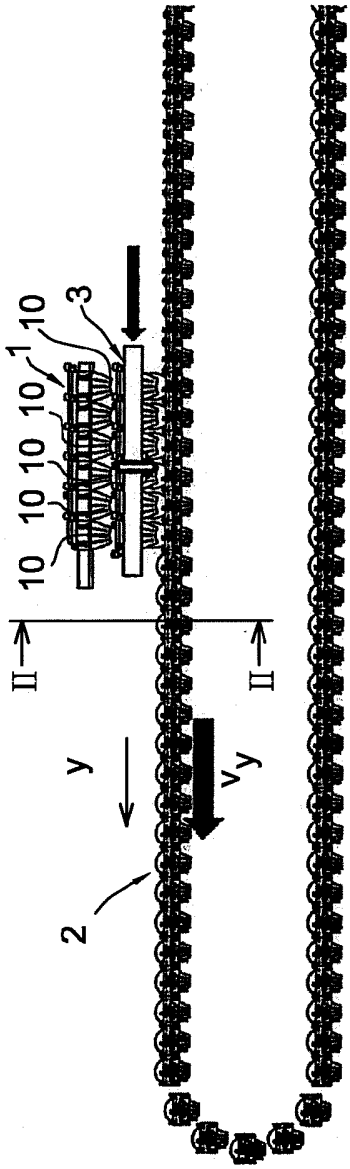

Fig. 1

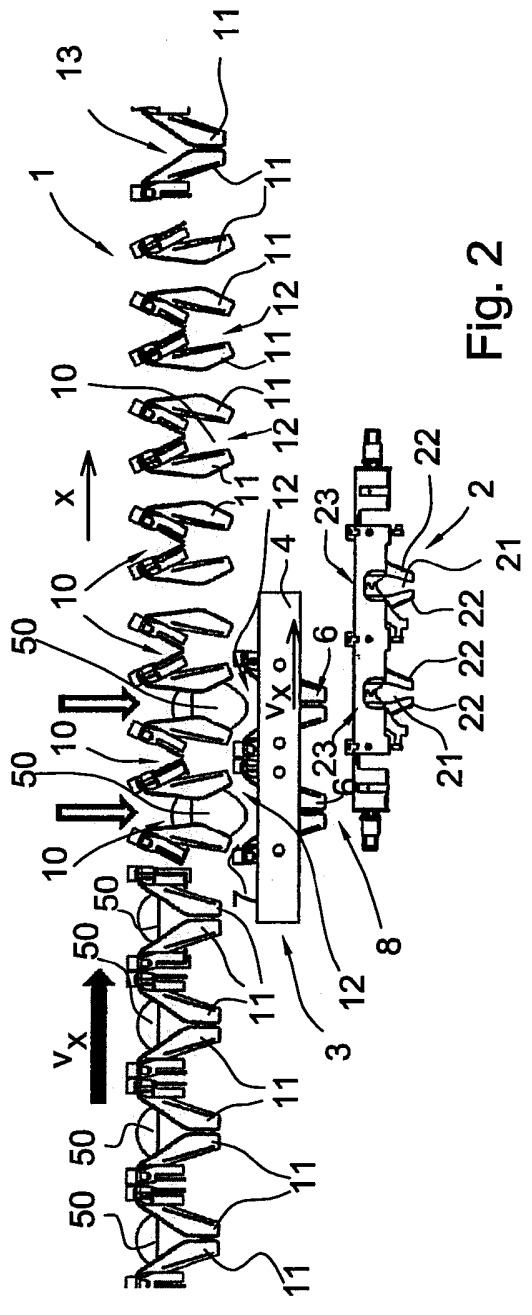

Fig. 2

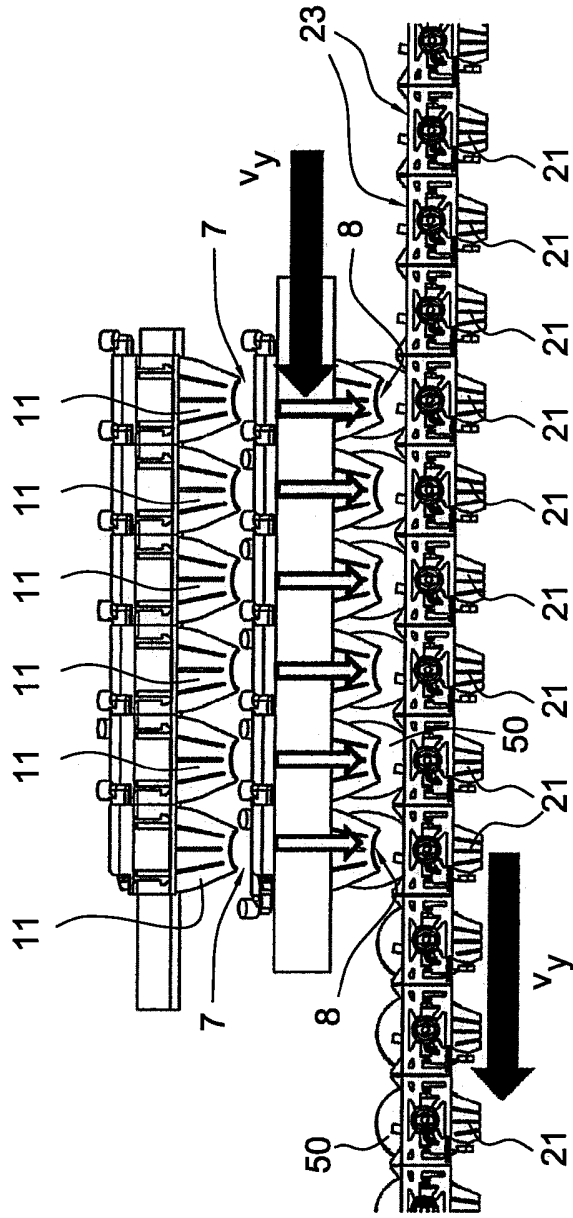

Fig. 3

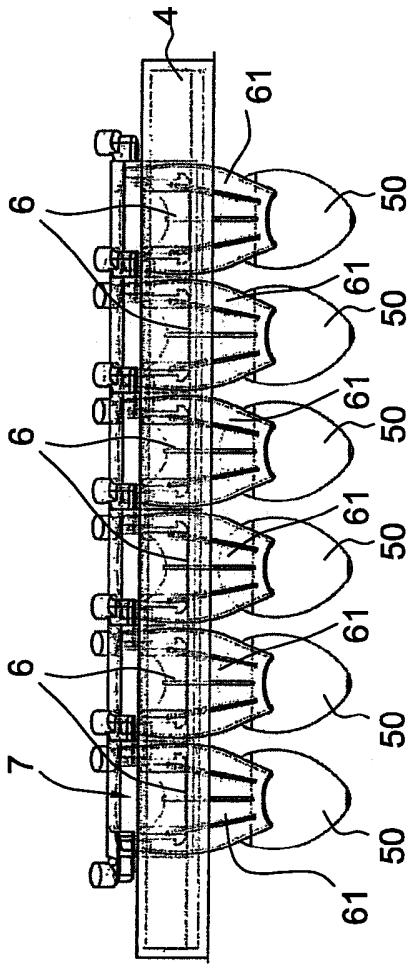

Fig. 5

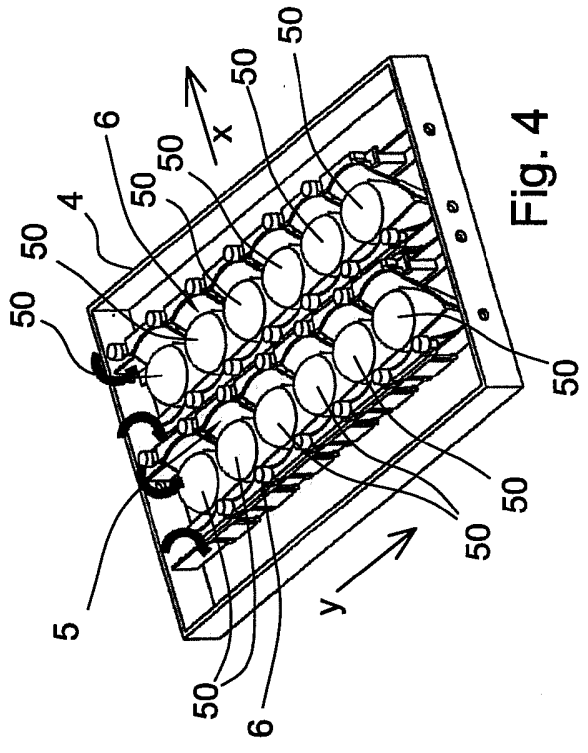

Fig. 4

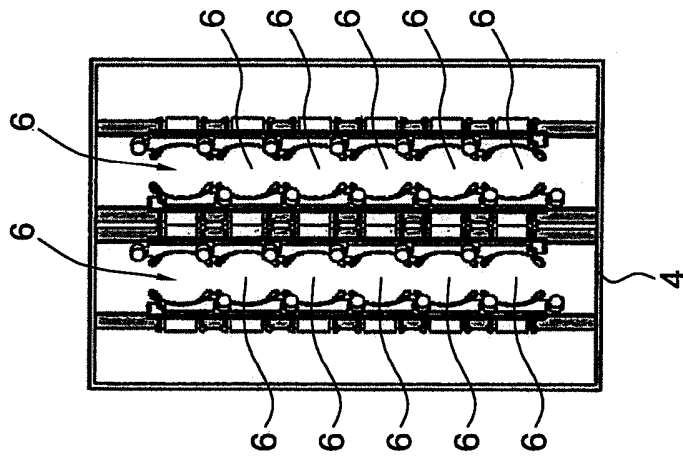

Fig. 6

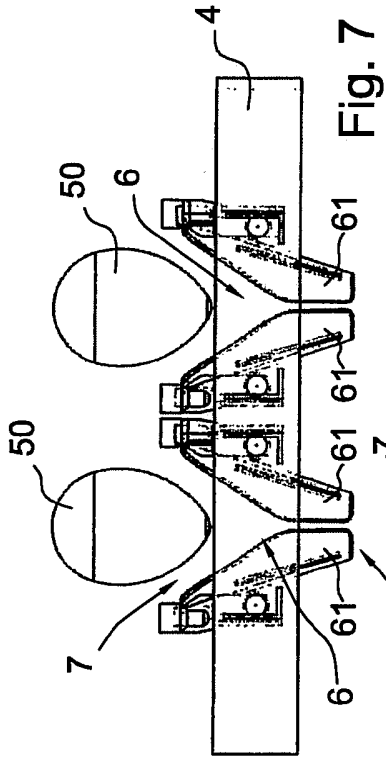
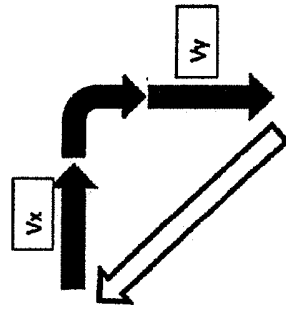

Fig. 7

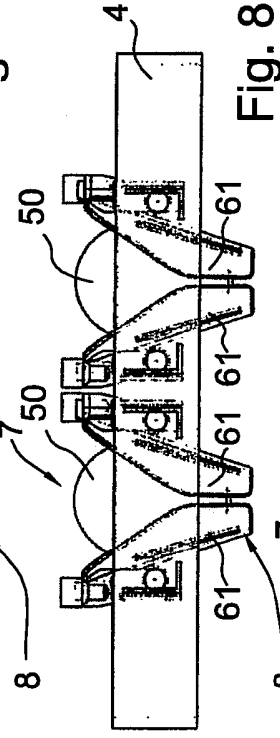

Fig. 8

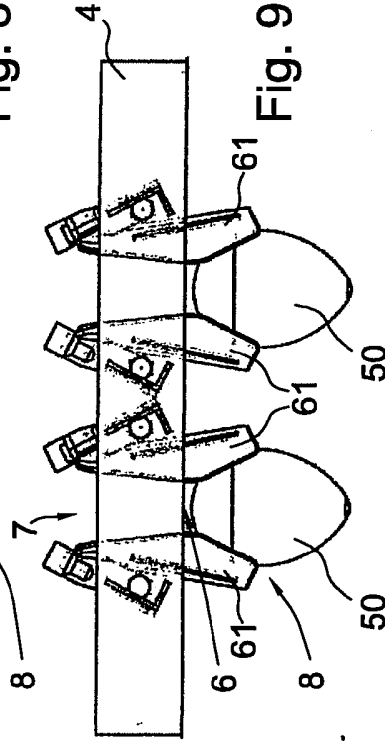

Fig. 9

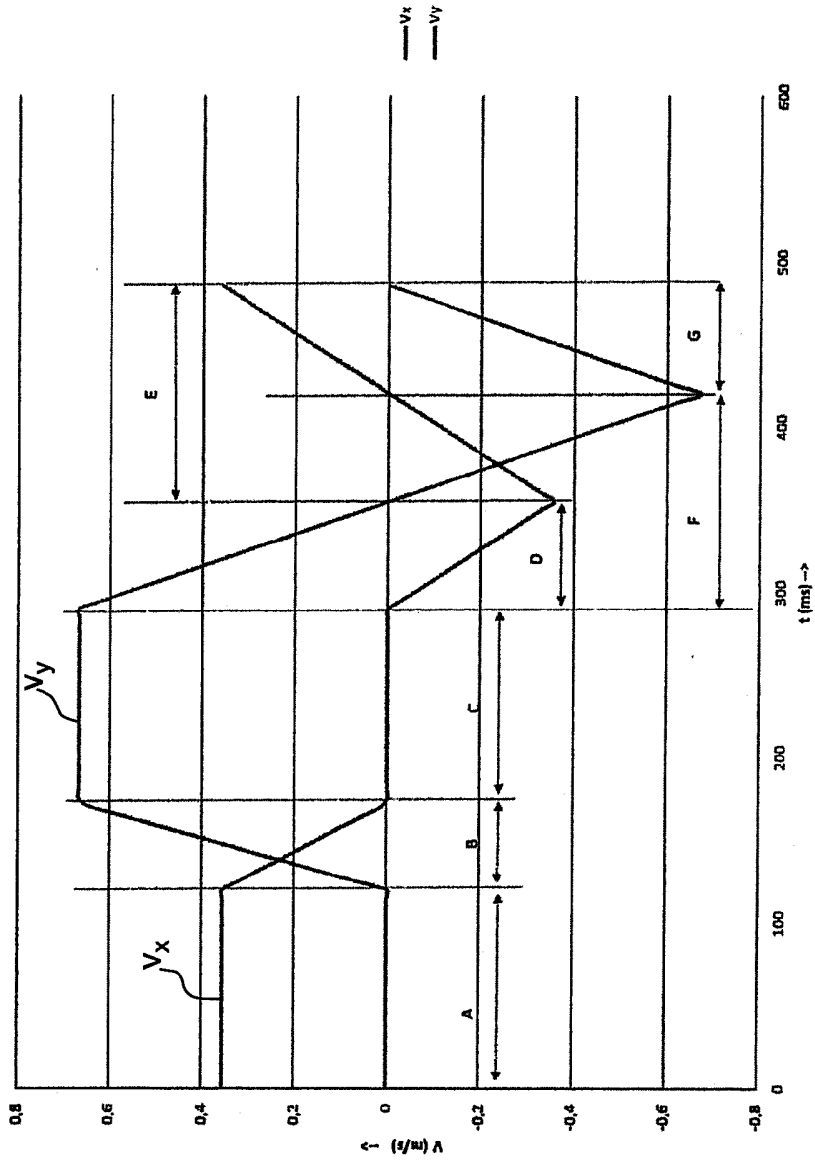

Fig. 10

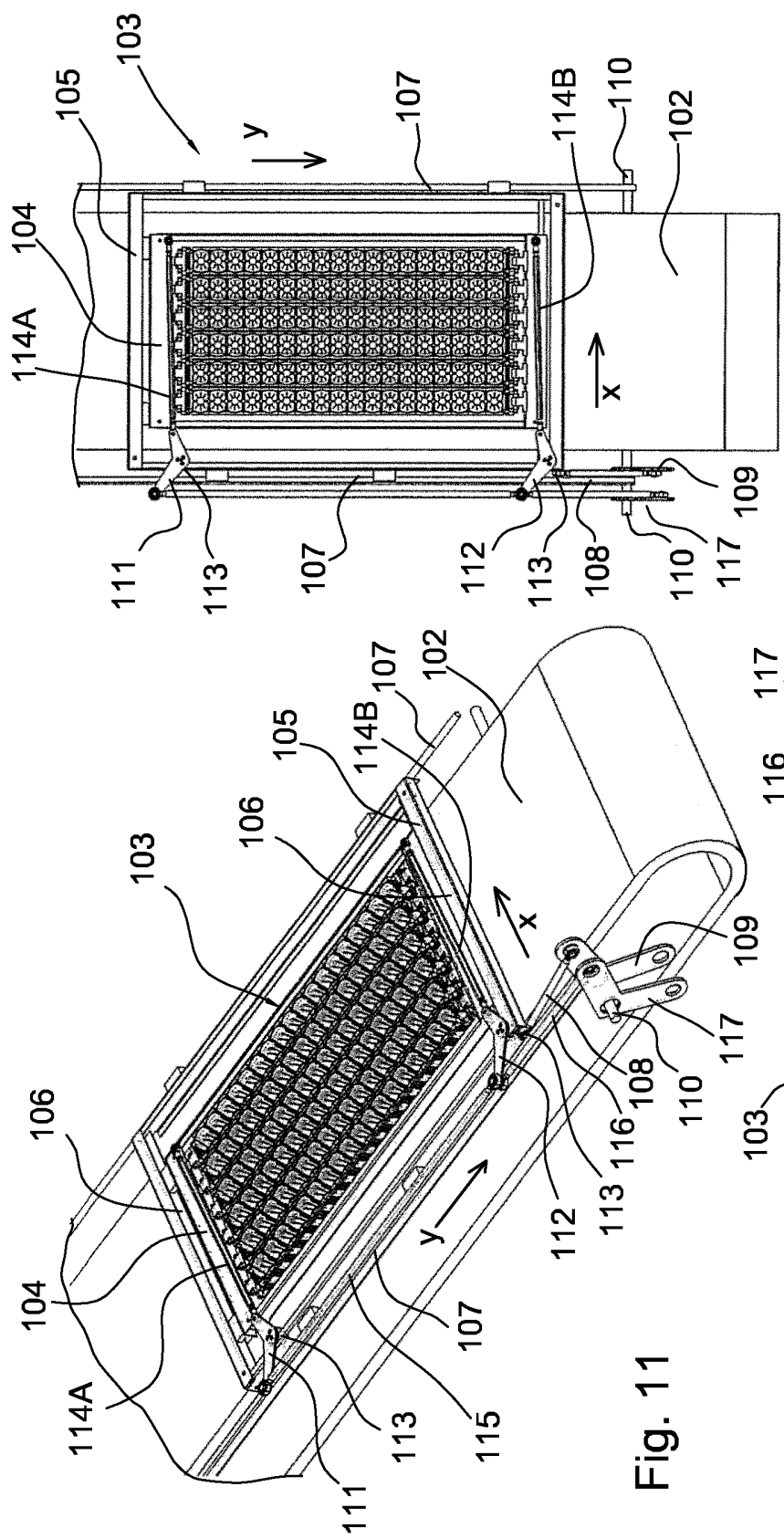

Fig. 11

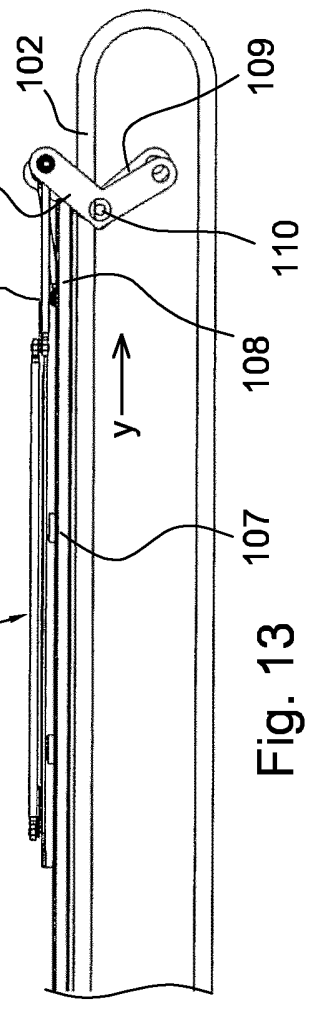

Fig. 12

Fig. 13

ABSTRACT

An egg conveyor assembly comprises a first conveyor comprising at least one lane of egg retainers that extends in a first conveyor direction (X) on a first height level. A second conveyor comprises at least one lane of egg retainers that extends in a second conveyor direction (Y) on a second height level. A transfer device adapted to transfer eggs from the first conveyor to the second conveyor comprises an array of egg retainers. The first conveyor and second conveyor cross each other, wherein the first height level is above the second height level. The egg retainers of the transfer device comprise pockets having a receiving opening at an upper end thereof to receive the eggs from above from the first conveyor, and are adapted to release the eggs at a lower end to drop the eggs in the egg retainers of the second conveyor. The transfer device is movable in the first conveyor direction (X) and in the second conveyor direction (Y) in a plane on a height level between the first height level and second height level.

SAMENWERKINGSVERDRAG (PCT)

RAPPORT BETREFFENDE NIEUWHEIDSONDERZOEK VAN INTERNATIONAAL TYPE

IDENTIFICATIE VAN DE NATIONALE AANVRAGE	KENMERK VAN DE AANVRAGER OF VAN DE GEMACHTIGDE <p style="text-align: center;">P32239NL00/CHO</p>
Nederlandse aanvraag nr. <p style="text-align: center;">2014158</p>	Indieningsdatum <p style="text-align: center;">19-01-2015</p>
Aanvrager (Naam) <p style="text-align: center;">Sanovo Technology Netherlands B.V.</p>	Ingeroepen voorrangedatum
Datum van het verzoek voor een onderzoek van internationaal type <p style="text-align: center;">11-04-2015</p>	Door de instantie voor Internationaal Onderzoek aan het verzoek voor een onderzoek van internationaal type toegekend nr. <p style="text-align: center;">SN63918</p>
I. CLASSIFICATIE VAN HET ONDERWERP (bij toepassing van verschilderde classificaties, alle classificatiesymbolen opgeven)	
Volgens de internationale classificatie (IPC) <p style="text-align: center;">B65B23/06;B65G47/38;B65G47/54</p>	
II. ONDERZOCHE TE GEBIEDEN VAN DE TECHNIEK	
Onderzochte minimumdocumentatie	
Classificatiesysteem	Classificatiesymbolen
<p>IPC</p>	<p>B65B;B65G</p>
Onderzochte andere documentatie dan de minimum documentatie, voor zover dergelijke documenten in de onderzochte gebieden zijn opgenomen	
III. <input type="checkbox"/>	GEEN ONDERZOEK MOGELIJK VOOR BEPAALDE CONCLUSIES (opmerkingen op aanvullingsblad)
IV. <input type="checkbox"/>	GEBREK AAN EENHEID VAN UITVINDING (opmerkingen op aanvullingsblad)

**ONDERZOEKSRAPPORT BETREFFENDE HET
RESULTAAT VAN HET ONDERZOEK NAAR DE STAND
VAN DE TECHNIEK VAN HET INTERNATIONALE TYPE**

Nummer van het verzoek om een onderzoek naar
de stand van de techniek

NL 2014158

A. CLASSIFICATIE VAN HET ONDERWERP
INV. B65B23/06 B65G47/38 B65G47/54
ADD.

Volgens de Internationale Classificatie van octrooien (IPC) of zowel volgens de nationale classificatie als volgens de IPC.

B. ONDERZOCHE GEBIEDEN VAN DE TECHNIEK

Onderzochte minimum documentatie (classificatie gevolgd door classificatiesymboolen)

B65B B65G

Onderzochte andere documentatie dan de minimum documentatie, voor dergelijke documenten, voor zover dergelijke documenten in de onderzochte gebieden zijn opgenomen

Tijdens het onderzoek geraadpleegde elektronische gegevensbestanden (naam van de gegevensbestanden en, waar uitvoerbaar, gebruikte trefwoorden)

EPO-Internal, WPI Data

C. VAN BELANGS GEACHTE DOCUMENTEN

Categorie *	Geciteerde documenten, eventueel met aanduiding van spesielt van belang zijnde passages	Van belang voor conclusie n°
A	US 5 232 080 A (VAN ESSEN HENK [NL] ET AL) 3 augustus 1993 (1993-08-03) * figuur 1 *	1
A	WO 2013/006052 A1 (FOOD PROCESSING SYSTEMS [NL]; VAN RAVENHORST BAREND [NL]) 10 januari 2013 (2013-01-10) * samenvatting *	1

Verder documenten worden vermeld in het verloop van vak C.

Leden van dezelfde octroofamilie zijn vermeld in een bijlage

*** Speciale categorieën van aangehaalde documenten**

"A" niet tot de categorie X of Y behorende literatuur die de stand van de techniek beschrijft

"D" in de octrooiaanvraag vermeld

"E" eerdere octrooi(aanvraag), gepubliceerd op of na de indieningsdatum, waarin dezelfde uitvinding wordt beschreven

"L" om andere redenen vermeldde literatuur

"O" met schriftelijke stand van de techniek

"P" tussen de voortgangdatum en de indieningsdatum gepubliceerde literatuur

"T" na de indieningsdatum of de voortgangdatum gepubliceerde literatuur die niet bezwaarlijk is voor de octrooiaanvraag, maar wordt vermeld ter verheldering van de theorie of het principe dat ten grondslag ligt aan de uitvinding

"X" de conclusie wordt als niet nieuw of niet inventief beschouwd ten opzichte van deze literatuur

"Y" de conclusie wordt als niet inventief beschouwd ten opzichte van de combinatie van deze literatuur met andere geciteerde literatuur van dezelfde categorie, waarbij de combinatie voor de verkeer voor de hand liggend wordt geacht

"Z" lid van dezelfde octroofamilie of overeenkomstige octrooipublicatie

Datum waarop het onderzoek naar de stand van de techniek van internationaal type werd voltooid

24 september 2015

Verzenddatum van het rapport van het onderzoek naar de stand van de techniek van internationaal type

Naam en adres van de instantie

European Patent Office, P.B. 2818 Patentlaan 2
NL - 2280 HV Rijswijk
Tel. (+31-70) 340-2040
Fax: (+31-70) 340-3218

De bevoegde ambtenaar

Schneider, Marc

**ONDERZOEKSRAPPORT BETREFFENDE HET
 RESULTAAT VAN HET ONDERZOEK NAAR DE STAND
 VAN DE TECHNIEK VAN HET INTERNATIONALE TYPE**

informatie over leden van dezelfde octrooifamilie

Nummer van het verzoek om een onderzoek naar
 de stand van de techniek

NL 2014158

In het rapport genoemd octrooigezinsft	Datum van publicatie	Overeenkomstige geschrift(en)	Datum van publicatie
US 5232080	A	03-08-1993	EP 0560458 A1 15-09-1993
			JP 3437854 B2 18-08-2003
			JP H06211213 A 02-08-1994
			US 5232080 A 03-08-1993

WO 2013006052	A1	10-01-2013	AU 2012278404 A1 23-01-2014
			CN 103813961 A 21-05-2014
			EP 2729372 A1 14-05-2014
			JP 2014520735 A 25-08-2014
			KR 20140062033 A 22-05-2014
			RU 2014100988 A 10-08-2015
			WO 2013006052 A1 10-01-2013

WRITTEN OPINION

File No. SN63918	Filing date (day/month/year) 19.01.2015	Priority date (day/month/year)	Application No. NL2014158
International Patent Classification (IPC) INV. B65B23/06 B65G47/38 B65G47/54			
Applicant Sarova Technology Netherlands B.V.			

This opinion contains indications relating to the following items:

- Box No. I Basis of the opinion
- Box No. II Priority
- Box No. III Non-establishment of opinion with regard to novelty, inventive step and industrial applicability
- Box No. IV Lack of unity of invention
- Box No. V Reasoned statement with regard to novelty, inventive step or industrial applicability; citations and explanations supporting such statement
- Box No. VI Certain documents cited
- Box No. VII Certain defects in the application
- Box No. VIII Certain observations on the application

	Examiner Schneider, Marc
--	------------------------------------

WRITTEN OPINION

Box No. I Basis of this opinion

1. This opinion has been established on the basis of the latest set of claims filed before the start of the search.
2. With regard to any **nucleotide and/or amino acid sequence** disclosed in the application and necessary to the claimed invention, this opinion has been established on the basis of:
 - a. type of material:
 - a sequence listing
 - table(s) related to the sequence listing
 - b. format of material:
 - on paper
 - in electronic form
 - c. time of filing/furnishing:
 - contained in the application as filed.
 - filed together with the application in electronic form.
 - furnished subsequently for the purposes of search.
3. In addition, in the case that more than one version or copy of a sequence listing and/or table relating thereto has been filed or furnished, the required statements that the information in the subsequent or additional copies is identical to that in the application as filed or does not go beyond the application as filed, as appropriate, were furnished.
4. Additional comments:

Box No. V Reasoned statement with regard to novelty, inventive step or industrial applicability; citations and explanations supporting such statement

1. Statement

Novelty	Yes: Claims	1-11
	No: Claims	
Inventive step	Yes: Claims	1-11
	No: Claims	
Industrial applicability	Yes: Claims	1-11
	No: Claims	

2. Citations and explanations

see separate sheet

WRITTEN OPINION

Application number
NL2014158

Box No. VII Certain defects in the application

see separate sheet

Re Item V

Reasoned statement with regard to novelty, inventive step or industrial applicability; citations and explanations supporting such statement

Reference is made to the following documents:

- D1 US 5 232 080 A (VAN ESSEN) 3 augustus 1993 (1993-08-03);
D2 WO 2013/006052 A1 (FPS) 10 januari 2013 (2013-01-10).

- 1 The subject-matter of claim 1 meets the requirements of novelty and inventive step.

Document D1 is regarded as being the prior art closest to the subject-matter of claim 1, and discloses:

een eiertransportsamenstel omvattende:

- *een eerste eindeloze transporteur (5) omvattende ten minste een baan van eierhouders (16-19) die zich in een eerste transporteurrichting op een eerste hoogteniveau uitstrekt.*
- *een tweede eindeloze transporteur (8) omvattende ten minste één baan van eierhouders die zich in een tweede transporteurrichting op een tweede hoogteniveau uitstrekt, waarbij het eerste hoogteniveau zich boven het tweede hoogteniveau bevindt, waarbij de eerste transporteurrichting en tweede transporteurrichting in hoofdzaak loodrecht op elkaar staan, waarbij de eerste transporteur (5) en tweede transporteur (10) elkaar kruisen, en*
- *een overdrachtsinrichting (7) ingericht om eieren van de eerste transporteur (5) naar de tweede transporteur (8) over te dragen en omvattende een matrix van eierhouders (55), waarbij de matrix ten minste een rij van eierhouders (55) heeft, waarbij elke rij een aantal eierhouders heeft dat overeenkomt met het aantal banen van de eerste transporteur (5), en welke matrix verder een aantal rijen heeft dat overeenkomt met het aantal banen van de tweede transporteur (8), waarbij de eierhouders (55) van de overdrachtsinrichting (7) buidels omvat met een opnameopening aan één bovenste einde ervan om de eieren van boven op te nemen vanaf de eerste transporteur (5), en zijn ingericht om de eieren bij een onderste einde los te laten om de eieren in de eierhouders van de tweede transporteur (8) te laten vallen.*

- 1.1 The subject-matter of claim 1 therefore differs from this known egg conveyor assembly in that "*de overdrachtsinrichting beweegbaar is in de eerste transporteurrichting en in de tweede transporteurrichting in een vlak op een hoogteniveau tussen het eerste hoogteniveau en het tweede hoogteniveau*". The subject-matter of claim 1 is thus new.
- 1.2 The problem to be solved by the present invention may be regarded as to have the possibility of increasing the pace of the assembly without increasing the risk of breaking eggs.
- 1.3 None of the cited documents discloses or suggests to provide a transfer device between two crossing conveyors with two degrees of freedom to be able to synchronize the movement of the transfer device with the movement of the first conveyor and than of the second conveyor.
The document D2 provides an alternative to the synchronization of the transfer between two crossing conveyors, which does not involve a transfer device provided between the first and the second conveyor. The Searching Authority is of the opinion that the application of the teaching of D2 to D1 would not lead obviously to an assembly wherein the transfer device can move in two perpendicular direction but to have the first and the second conveyor of D1 modified according to D2.
The subject-matter of claim 1 involves thus an inventive step.
- 2 Claims 2-11 are dependent on claim 1 and as such also meet the requirements of novelty and inventive step.

Re Item VII

Certain defects in the application

- 3 Although claim 1 is drafted in the two-part form, some features are incorrectly placed in the characterising portion, as it is disclosed in D1 in combination with the features placed in the preamble: see point 1.1.
- 4 The features of the claims are not provided with reference signs placed in parentheses.
- 5 The relevant background art disclosed in D1 and D2 is not mentioned in the description, nor is this document identified therein.