

(19) World Intellectual Property Organization  
International Bureau



(43) International Publication Date  
11 November 2004 (11.11.2004)

PCT

(10) International Publication Number  
WO 2004/098050 A2

- (51) International Patent Classification<sup>7</sup>: **H03G**
  - (21) International Application Number: PCT/US2004/011657
  - (22) International Filing Date: 13 April 2004 (13.04.2004)
  - (25) Filing Language: English
  - (26) Publication Language: English
  - (30) Priority Data: 10/423,829 24 April 2003 (24.04.2003) US
  - (71) Applicant (for all designated States except US): **DOLBY LABORATORIES LICENSING CORPORATION** [US/US]; 100 Potrero Avenue, San Francisco, CA 94103 (US).
  - (72) Inventor; and
  - (75) Inventor/Applicant (for US only): **JACOBS, Stephen, M.** [US/US]; 100 Potrero Avenue, San Francisco, CA 94103 (US).
  - (74) Agents: **GALLAGHER, Thomas, A.** et al.; Gallagher & Lathrop, 601 California Street, Suite 1111, San Francisco, CA 94108-2805 (US).
  - (81) Designated States (unless otherwise indicated, for every kind of national protection available): AE, AG, AL, AM, AT, AU, AZ, BA, BB, BG, BR, BW, BY, BZ, CA, CH, CN, CO, CR, CU, CZ, DE, DK, DM, DZ, EC, EE, EG, ES, FI, GB, GD, GE, GH, GM, HR, HU, ID, IL, IN, IS, JP, KE, KG, KP, KR, KZ, LC, LK, LR, LS, LT, LU, LV, MA, MD, MG, MK, MN, MW, MX, MZ, NA, NI, NO, NZ, OM, PG, PH, PL, PT, RO, RU, SC, SD, SE, SG, SK, SL, SY, TJ, TM, TN, TR, TT, TZ, UA, UG, US, UZ, VC, VN, YU, ZA, ZM, ZW.
  - (84) Designated States (unless otherwise indicated, for every kind of regional protection available): ARIPO (BW, GH, GM, KE, LS, MW, MZ, SD, SL, SZ, TZ, UG, ZM, ZW), Eurasian (AM, AZ, BY, KG, KZ, MD, RU, TJ, TM), European (AT, BE, BG, CH, CY, CZ, DE, DK, EE, ES, FI, FR, GB, GR, HU, IE, IT, LU, MC, NL, PL, PT, RO, SE, SI, SK, TR), OAPI (BF, BJ, CF, CG, CI, CM, GA, GN, GQ, GW, ML, MR, NE, SN, TD, TG).
- Published:**  
— without international search report and to be republished upon receipt of that report

[Continued on next page]

(54) Title: VOLUME CONTROL IN MOVIE THEATERS

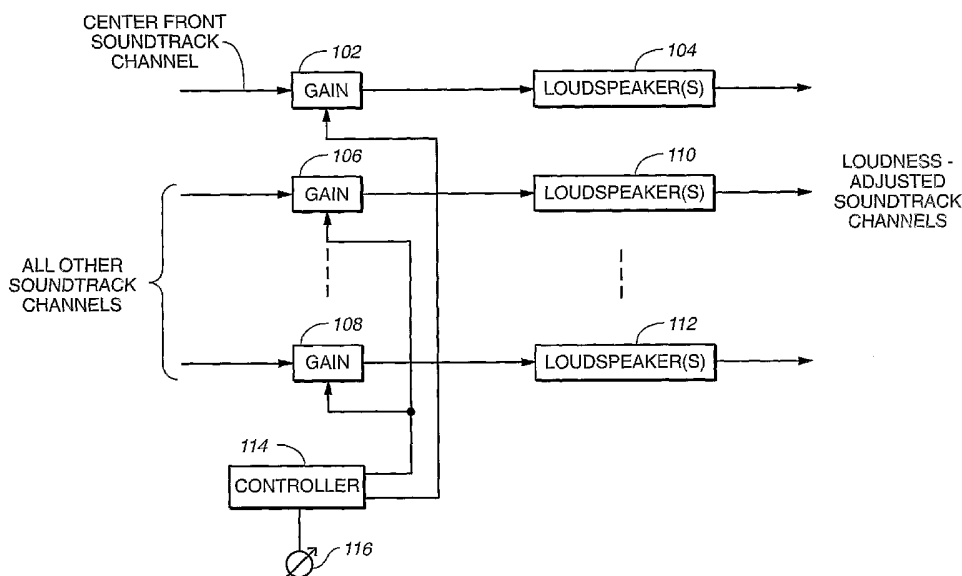

(57) Abstract: A motion picture soundtrack reproduction system has a center front soundtrack channel and a plurality of other soundtrack channels. A volume control adjusts the gain of all the channels. The volume control has a range of settings from a minimum to a maximum, the gain of the center front channel having substantially a first relationship to the volume control settings and the gain of the other channels having substantially a second relationship to the volume control settings, the relationships being such that for a range of volume control settings less than a first setting the gain of the center front channel remains substantially constant while the gain of the other channels decreases as the setting decreases or decreases more gradually than the gain of the other channels as the setting decreases.

WO 2004/098050 A2



---

*For two-letter codes and other abbreviations, refer to the "Guidance Notes on Codes and Abbreviations" appearing at the beginning of each regular issue of the PCT Gazette.*

## DESCRIPTION

### Volume Control in Movie Theaters

#### TECHNICAL FIELD

5           The invention relates generally to the processing of audio signals. More particularly, the invention relates to control of the loudness of motion picture soundtracks when reproduced.

#### BACKGROUND ART

          In the mid-1970s, Dolby Laboratories introduced a calibration  
10 recommendation for monitor levels in movie soundtracks ("Dolby" is a trademark of Dolby Laboratories, Inc.). A pink noise reference signal was used in the record chain to adjust the audio monitor level to 85 dBc. All theatres equipped for playback of the new stereo optical soundtracks were set up such that an equivalent pink noise signal  
15 (fader) set to the calibrated setting. This meant that theatres playing films at the calibrated volume control setting (a setting of "7" in a range of "0" to "10" on most cinema processors) reproduced the same loudness level selected by the film director and audio engineers in the dubbing theatre (referred to herein as "the mixer").

          This system worked quite well for many years. Dolby Stereo (A-type  
20 encoded) films had limited headroom and the resulting constrained dynamic range yielded few audience complaints. Most theatres played films at the calibrated level. Soundtrack format technology has been significantly enhanced since Dolby Stereo. Dolby SR extended the headroom by 3 dB at midrange frequencies, and more at low and high frequencies. In recent years, the new digital formats have further increased  
25 the headroom. FIG. 1 shows maximum sound pressure level of one reproduced soundtrack channel versus frequency for four photographic soundtrack formats, Academy mono, Dolby A-type, Dolby SR and Dolby Digital. The curves are normalized with respect to their reference levels. Thus, they show the maximum sound pressure level that one channel of each different optical soundtrack system is

capable of when playing a motion picture at the calibrated volume control setting in a properly set up theater. The maximum sound pressure level in a theater is also a function of the number of soundtrack channels. For example, five channels can deliver 2.5 times as much power as two channels, resulting in an increase of 4 dB in sound pressure level. Thus, in the case of five or seven channel digital soundtrack reproduction, for example, the increase in peak sound pressure level is even greater than that shown in FIG. 1.

Because the 85 dBc calibration technique has been maintained throughout evolving format changes, additional headroom is available on the newer soundtracks. However, feature films do have a consistent, subjective mix reference, independent of increased headroom, for dialogue record level, known as "associative loudness." When the dubbing mixer sees an actor on the screen, and there is no conflict between the dialogue and music or effects, the dialogue level in a moderate close-up is set to be plausible for the visual impression. Within reasonable limits, this generally holds true to within 2 or 3 dB. This natural dialogue level does not hold true for narration, as there is no corresponding visual reference. Music and effects have no direct visual associative loudness. Most people are not familiar with the actual sound pressure levels of a Concorde takeoff or a 50 mm howitzer. The music score level is equally uncalibrated.

As the headroom capability of the recording medium has been extended, it has certainly been used: the "non-associative" loudness of effects and music has risen to fill the available headroom space. Using dialogue as a reference, loud sounds like explosions are often 20 dB or more louder (explosions reach full scale peak level of 25 dB above dialogue level), and some quiet sounds, which are intended to be heard by all listeners, such as leaves rustling, may be 50 dB quieter.

In response to audience complaints that movies are too loud, many theatres are playing films substantially below the calibrated level. A volume control setting (fader level) of "6" or "5 1/2," as opposed to the calibrated level (volume control standard setting) of "7," is not uncommon, representing a loudness reduction of

approximately 4 or 6 dB. Some cinemas have their volume control permanently turned down to such settings because projectionists operating multiplexes with many screens showing different movies simultaneously don't have the time or cannot be bothered to set the controls differently for different movies. If the volume control is turned down to avoid complaints of excessive loudness, the dialogue is quieter than the mixer intended, and audiences may complain instead that some dialogue is not intelligible in the presence of other sounds in the film and/or general background noise of the theater (popcorn eating, air-conditioning, people talking, etc.). Theatre playback levels are often set by complaints generated by the loudest (and earliest) element of the show. If the playback level is set in response to the loudest trailer (preview), which is often louder than the feature film, the feature often plays at the same reduced level. The result is that the dialogue level of the feature is lowered by the same level deemed necessary to attenuate the trailer. A feature film played with a loudness 6 dB below the calibrated level may have serious dialogue intelligibility problems and very quiet sounds may become inaudible.

In addition, it is possible that the increased use of headroom from Dolby A-type to Dolby SR and digital releases has not been matched by a corresponding increase in power amplifier and loudspeaker capability. The resultant distortion from overloaded equipment may well exacerbate the loudness problems of recent soundtracks, causing increased incidence of complaints.

In early cinema sound equipment employing calibration, the volume control was a mechanical potentiometer, often with a click-stop or detent at the standard setting. More recent (digital) equipment uses a shaft encoder or a pair of up-down buttons (with a numeric display for the setting), delivering a control signal that operates on multipliers (either digital or voltage-controlled amplifiers) to affect the gain applied to all channels of the reproduced soundtracks. In typical cinema sound equipment, the volume control varies the gain gradually and relatively uniformly over a range of settings from about "4" to "10," with the gain falling more rapidly at setting below about "4," allowing a fade to inaudibility. Such a typical prior art



more loudspeakers, and a controller having a volume control for adjusting the gain of all the channels, the volume control having a range of settings from a minimum to a maximum, the gain of the center front channel having a first relationship to the volume control settings and the gain of the other channels having a second  
5 relationship to the volume control settings, the relationships being such that for a range of volume control settings less than a first setting the gain of the center front channel remains substantially constant while the gain of the other channels decreases as the setting decreases or decreases more gradually than the gain of the other channels as the setting decreases.

10 The range of volume control settings less than the first setting extends down to the minimum control setting or, alternatively, down to a second setting above the minimum control setting. In the latter case, for settings less than the second setting the gains of all the channels decrease in substantially the same way as the setting decreases and for such volume control settings the gain of the center front channel is  
15 greater than the gain of the other channels. Optionally, for settings less than the second setting the gain of the center front channel is greater than the gain of the other channels by a substantially constant amount in the logarithmic domain.

For settings greater than the first setting the gains of all the channels may increase as the setting increases and for each of such volume control settings the gain  
20 of the center front channel and the gain of the other channels may be substantially the same.

The invention is particularly advantageous in an arrangement in which when the volume control is set to a standard setting, each of the channels has a respective gain that produces a respective standard acoustic level in response to a signal having  
25 a respective standard reference level in the channel. In that case, the first setting is about the standard setting.

The invention provides for reducing the maximum loudness, and thereby avoiding complaints, while maintaining the acoustic level of the center front containing dialogue and requiring only one user-operated control. According to an

embodiment of the invention, the cinema equipment is designed and installed in the conventional manner to the extent that with the volume control nominally at its standard setting, each of the reproduced soundtrack channels has a respective gain that produces a respective standard acoustic level in response to a signal having a  
5 respective standard reference level in the channel, thus matching the standard levels in a film mixing room. Thus, when calibrated, the playback system with its volume control at the standard setting has an apparent loudness that is substantially the same as that intended by the film mixer. However, in accordance with the present invention, if the volume control is turned down below the standard setting in  
10 response to actual (or expected) complaints from the audience, over a limited range of settings all channels except the center front are attenuated equally, but the center front is reduced by a smaller degree (or not at all). The effect is not only a reduction in the overall loudness but an increase in the proportionate contribution of the center front channel, with a potential improvement in intelligibility when the other channels  
15 are loud. Optionally, after some degree of changing the balance of the center front to other channels down to a setting below the standard setting, for further lowering of the settings all channels are attenuated equally, maintaining fixed the altered balance.

### DESCRIPTION OF THE DRAWINGS

FIG. 1 shows maximum sound pressure level versus frequency for four  
20 photographic soundtrack formats, Academy mono, Dolby A-type, Dolby SR and Dolby Digital.

FIG. 2 shows one set of suitable relationships between gain of the center front soundtrack channel and gain of each of the other soundtrack channels versus volume control setting, in which a gain of 0 dB is obtained for the standard volume control  
25 setting.

FIG. 3 is a simplified block diagram showing an implementation of the present invention from a structural standpoint.

FIG. 4 is a simplified block diagram showing an implementation of the present invention from a functional standpoint.

## BEST MODE FOR CARRYING OUT THE INVENTION

FIG. 2 illustrates idealized curves of gain/loss as a function of volume control setting, for the center front channel (upper line) and for each of the remaining channels (lower line). The lower line also shows the typical gain/loss for all channels (rather than channels other than the center front channel, as in the present invention) as a function of volume control setting in prior art motion picture sound equipment. While the characteristic responses shown in the example of FIG. 2 are practical and useful ones, the precise characteristics are not critical. For example, the lower characteristic curve need not be the same as in the prior art gain/loss for all channels versus volume control setting. The characteristics shown in the figures are just one example of suitable characteristics that fall within the scope of the invention

Still referring to FIG. 2, it will be seen that the gain of the center front channel has a first relationship to the volume control settings and that the gain of each of the other channels has a second relationship to the volume control settings. In FIG. 2, 0 dB is defined as the gain with the volume control at a first setting, the standard "7" setting. As shown in FIG. 2, for settings less than the first setting down to a second setting, the gain of the center front channel decreases more gradually than the gain of the other channels as the setting decreases. Alternatively, over a limited range of settings just below the standard setting, for instance between a setting of "7" and a setting of "6," the center channel gain may be constant as the gain of the other channels changes. Although such changes in gain (either alternative) may extend down to the minimum volume control setting, in a practical embodiment such changes in gain preferably do not extend down to the minimum setting but rather to a second setting, which may be a setting of about "5," for example, as shown in FIG. 2. In that case, for settings below the second setting, the gains of all the channels decrease in substantially the same way as the setting decreases and for such volume control settings the gain of the center front channel is greater than the gain of the other channels by a few dB, for example, as shown in FIG. 2. Preferably, for settings above the nominal standard setting up to a maximum setting, the gains of all the

channels increase as the setting increases and for each of such volume control settings the gain of the center front channel and the gain of the other channels are substantially the same. It should be understood that the relationships between the gain of the center front channel, on one hand, and the gain of the other channels, on the other hand, versus the volume control settings need not be precisely in accordance with the examples of FIG. 2, but are to be limited only by the scope of the appended claims.

An exemplary system according to the present invention is shown in FIG. 3. A center front soundtrack channel has a gain adjuster 102 that controls the gain of the channel. The channel feeds one or more loudspeakers 104 via a power amplifier (not shown). In practice, the gain adjuster 102 may be, for example, the gain or volume control of a preamplifier or a passive variable loss at the output (preferably the output rather than the input) of a preamplifier. A plurality of other channels, shown for simplicity as two channels, each has a respective gain adjuster 106 and 108. Each channel feeds one or more respective loudspeakers 110 and 112 via respective power amplifiers (not shown). The gain adjuster 102 for the center front channel is controlled by a first output of a controller 114 and the gain adjusters 106 and 108 for the other channels are controlled by a second output of controller 114, in the manner described herein in response to the setting of the controller's volume control 116.

In a practical arrangement employing digital controls, as shown in FIG. 4, the volume control setting may select values in first and second lookup tables 202 and 204. The first lookup table 202 in turn may adjust a multiplier controlling volume 206 in the center front channel, while the second lookup table 204 may adjust multipliers controlling volume 208 and 210 in the other channels. Lookup table values in response to volume control settings may be chosen so as to provide the desired relationships between gains in the various channels versus setting.

The present invention and its various aspects may be implemented in analog circuitry, for example, with two suitable non-linear functions relating control setting to gain, or as software functions performed in digital signal processors, programmed

general-purpose digital computers, and/or special purpose digital computers, or some combination of such devices and functions. Interfaces between analog and digital signal streams may be performed in appropriate hardware and/or as functions in software and/or firmware.

**CLAIMS**

1. A motion picture soundtrack reproduction system, the system having a center front soundtrack channel and a plurality of other soundtrack channels, comprising

5 a volume control for adjusting the gain of all the channels, the volume control having a range of settings from a minimum to a maximum, the gain of the center front channel having substantially a first relationship to the volume control settings and the gain of the other channels having substantially a second relationship to the volume control settings, the relationships being such that for a range of volume control settings less than a first setting the gain of the center front channel remains  
10 substantially constant or decreases more gradually than the gain of the other channels as the setting decreases.

2. A motion picture soundtrack reproduction system, comprising

15 a center front soundtrack channel and a plurality of other soundtrack channels, each of said channels having adjustable gain and one or more loudspeakers, and a controller having a volume control for adjusting the gain of all the channels, the volume control having a range of settings from a minimum to a maximum, the gain of the center front channel having a first relationship to the volume control settings and the gain of the other channels having a second relationship to the volume  
20 control settings, the relationships being such that for a range of volume control settings less than a first setting the gain of the center front channel remains substantially constant while the gain of the other channels decreases as the setting decreases or decreases more gradually than the gain of the other channels as the setting decreases.

25

3. A system according to claim 1 or claim 2 wherein the range of volume control settings less than said first setting extends down to the minimum control setting.

5           4. A system according to claim 1 or claim 2 wherein the range of volume control settings less than said first setting extends down to a second setting above the minimum control setting.

10           5. A system according to claim 3 wherein for settings less than said second setting the gains of all the channels decrease in substantially the same way as the setting decreases and for such volume control settings the gain of the center front channel is greater than the gain of the other channels.

15           6. A system according to claim 5 wherein for settings less than said second setting the gain of the center front channel is greater than the gain of the other channels by a substantially constant amount in the logarithmic domain.

20           7. A system according to any one of claims 1-6 wherein for settings greater than said first setting the gains of all the channels increase as the setting increases and for each of such volume control settings the gain of the center front channel and the gain of the other channels are substantially the same.

25           8. A system according to any one of claims 1-7 wherein when the volume control is set to a standard setting, each of the channels has a respective gain that produces a respective standard acoustic level in response to a signal having a respective standard reference level in the channel.

          9. A system according to claim 8 wherein said first setting is about said standard setting.

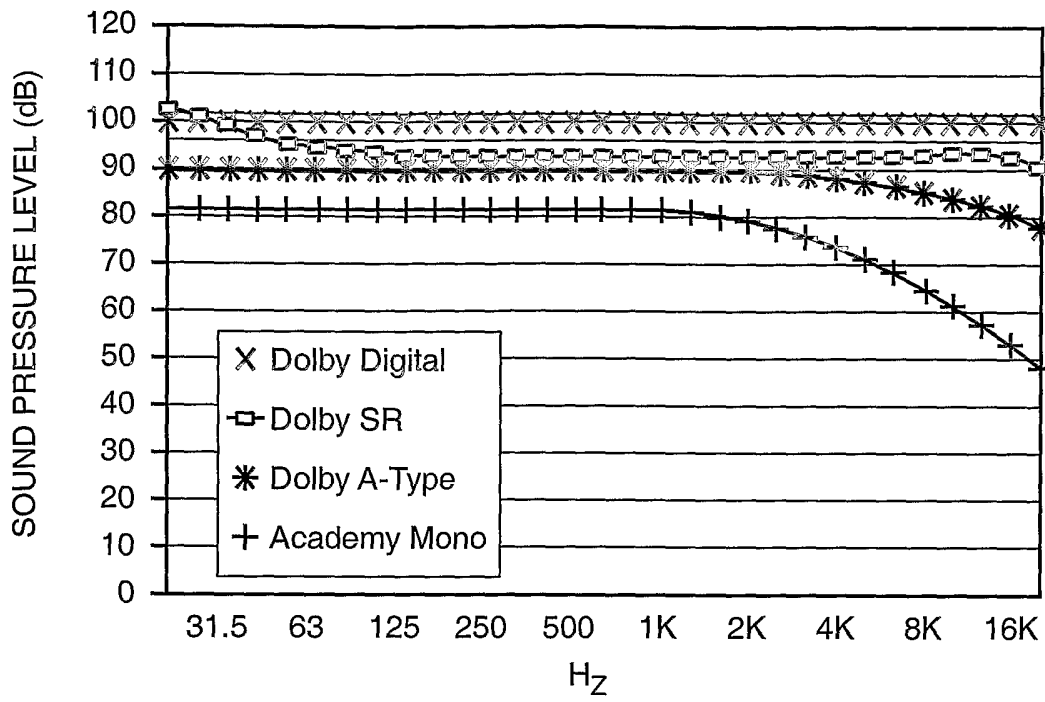

**FIG.\_1**

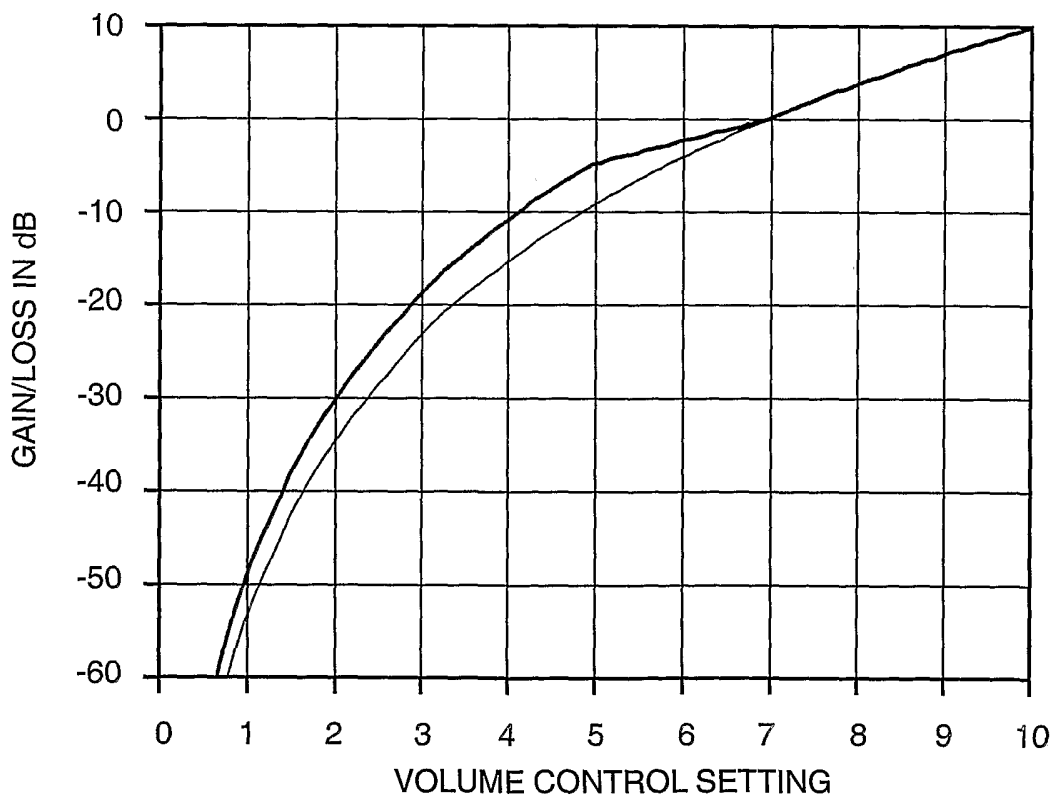

**FIG.\_2**

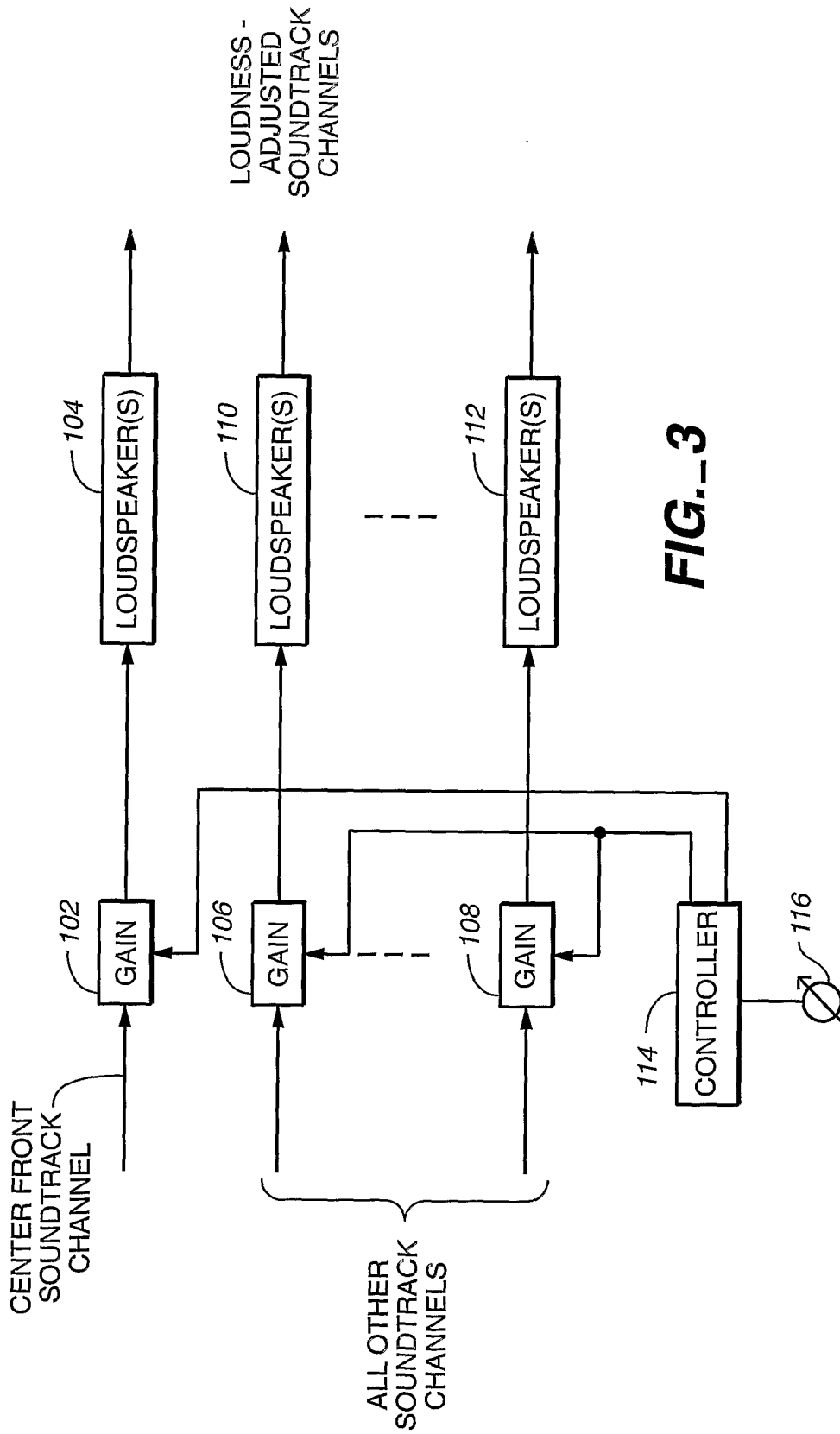

**FIG. 3**

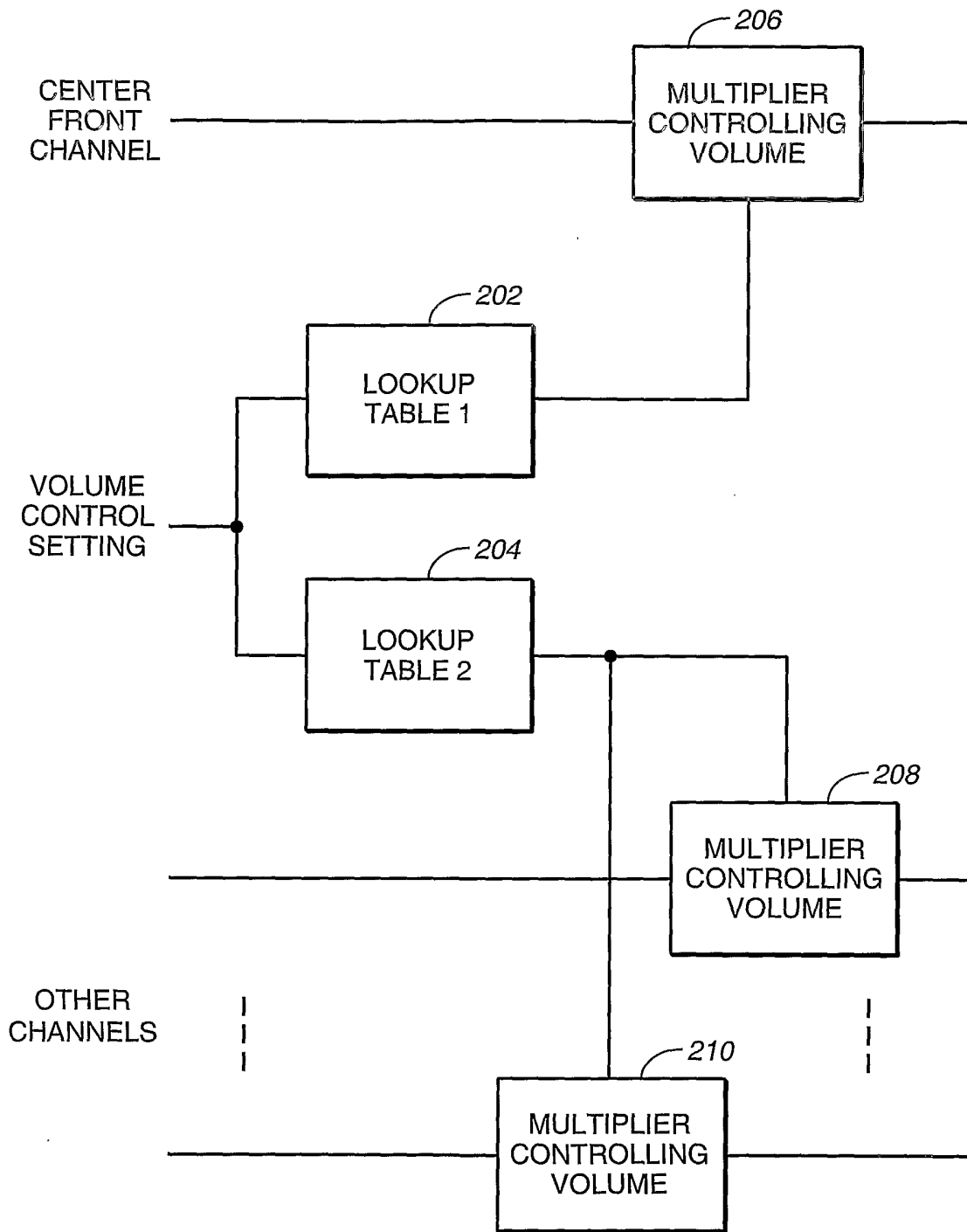

**FIG. 4**