

J. H. TAYLOR, DEC'D.

E. W. TAYLOR, EXECUTRIX.

ELEVATOR.

APPLICATION FILED SEPT. 7, 1909.

Patented June 28, 1910.

2 SHEETS—SHEET 1.

962,991.

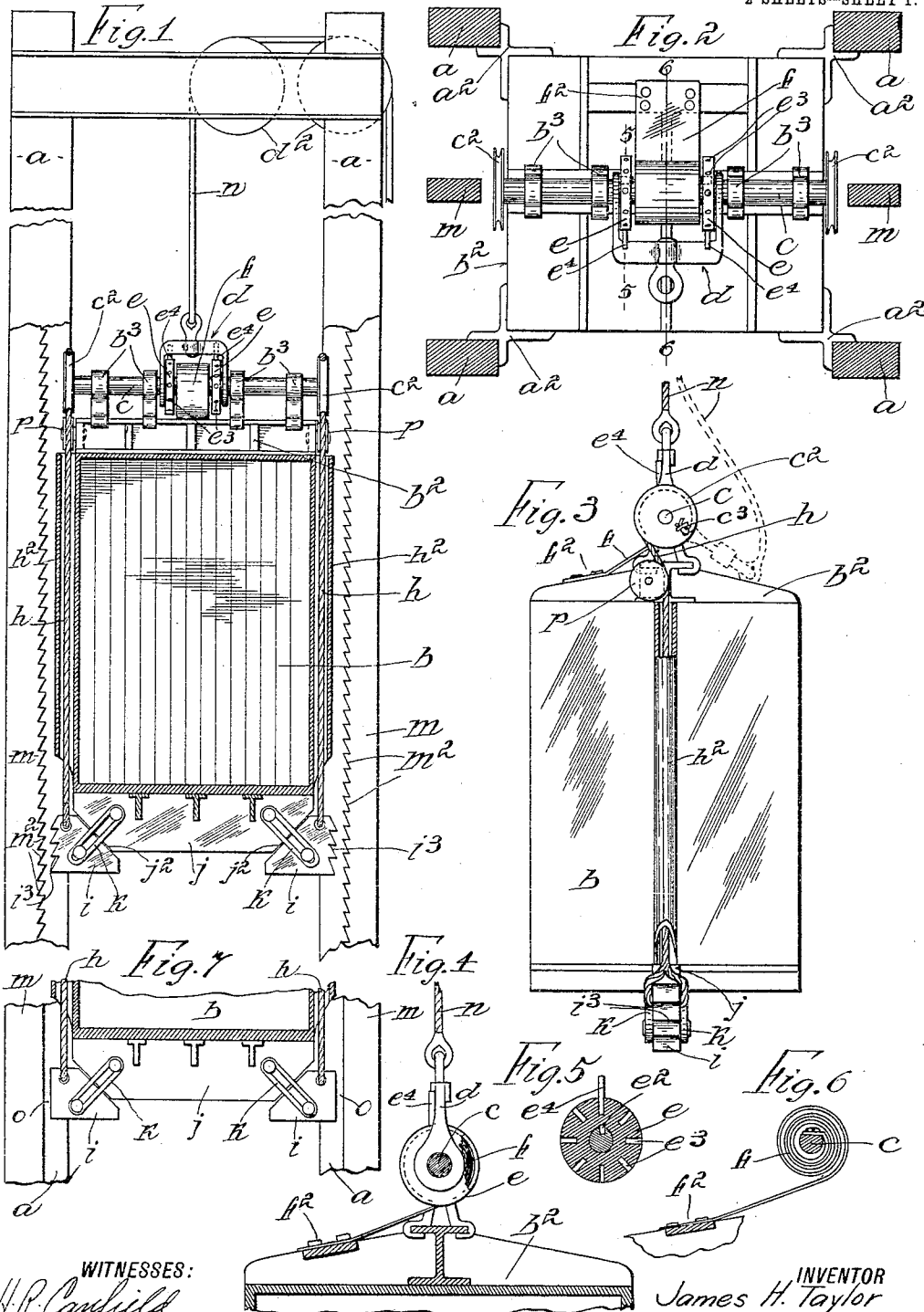

WITNESSES:
H. R. Canfield
G. E. Mulreany.

INVENTOR
James H. Taylor

BY *Edgar Tate & Co.*
ATTORNEYS.

J. H. TAYLOR, DEC'D.
 E. W. TAYLOR, EXECUTRIX.
 ELEVATOR.

962,991.

Patented June 28, 1910.
 2 SHEETS—SHEET 2.

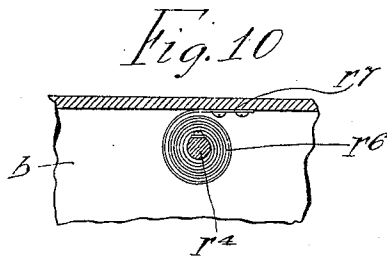
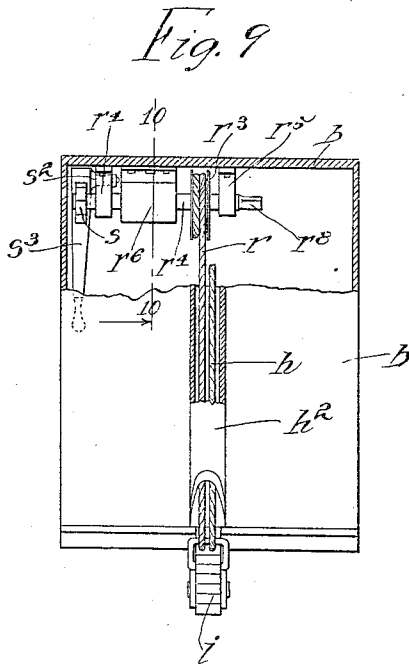
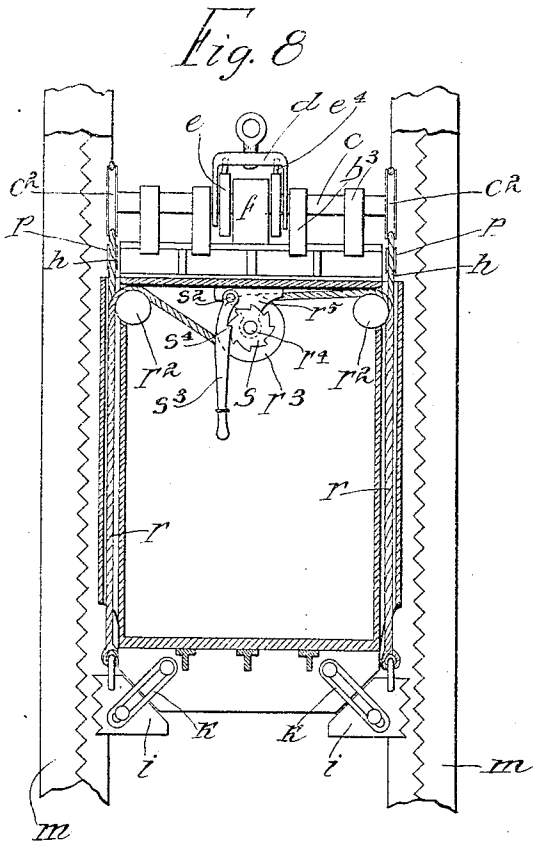

UNITED STATES PATENT OFFICE.

JAMES H. TAYLOR, OF BROOKLYN, NEW YORK; ELIZA W. TAYLOR EXECUTRIX OF SAID
JAMES H. TAYLOR, DECEASED.

ELEVATOR.

962,991.

Specification of Letters Patent. Patented June 28, 1910.

Application filed September 7, 1909. Serial No. 516,360.

To all whom it may concern:

Be it known that I, JAMES H. TAYLOR, a citizen of the United States, and residing at Brooklyn, in the county of Kings and State of New York, have invented certain new and useful Improvements in Elevators, of which the following is a specification, such as will enable those skilled in the art to which it appertains to make and use the same.

This invention relates to elevators and particularly to what are known as passenger elevators, and the object thereof is to provide an improved safety attachment for elevators of this class whereby, if the cable by which the elevator is raised and lowered should at any time be broken the downward movement of the elevator car would at once be checked or stopped and serious or fatal accidents avoided; and with this and other objects in view the invention consists in a safety attachment for elevators constructed and operating as hereinafter described and claimed.

The invention is fully disclosed in the following specification, of which the accompanying drawings form a part, in which the separate parts of my improvement are designated by suitable reference characters in each of the views, and in which;—

Figure 1 is a sectional side view of an elevator apparatus involving my invention, part of the construction being also broken away. Fig. 2. a plan view of the construction shown in Fig. 1 but showing the parts in a different position and showing the upright portion of the elevator shaft in section. Fig. 3. a side view of the elevator car at right angles to that shown in Fig. 1 with part of the construction broken away. Fig. 4. a sectional view of the top part of the car at right angles to that shown in Fig. 1 and showing only details of the construction. Fig. 5. a partial sectional view on the line 5—5 of Fig. 2. Fig. 6. a partial sectional view on the line 6—6 of Fig. 2 and showing only a detail of the construction. Fig. 7. a view similar to Fig. 1 but showing only a part of the construction shown in Fig. 1, and also showing a modification. Fig. 8. a view similar to Fig. 1 but showing a modification. Fig. 9. a sectional side view of the car shown in Fig. 8, and Fig. 10. a partial section on the line 10—10 of Fig. 9.

In the drawing forming part of this speci-

fication I have shown at *a* the upright corner posts of an elevator shaft said corner posts being provided with guides *a*² in or between which the car *b* is vertically movable. The car *b* is provided with a top frame work *b*² having keepers or bearings *b*³ in which is mounted a transverse shaft *c* which is provided at its ends with pulleys *c*². The keepers or bearings *b*³, in the form of construction shown, are arranged in pairs and mounted on the shaft *c*, centrally thereof, and between the separate pairs of keepers or bearings *b*³ is a yoke *d* which is rotatable on said shaft and within said yoke and adjacent to the opposite side portions thereof are wheels or disks *e* which are secured to said shaft, or keyed thereto as shown at *e*² in Fig. 5, and the wheels or disks *e* are provided in the perimeter thereof with sockets *e*³, any desired number of which may be employed and said sockets are adapted to receive pins *e*⁴ which in practice operate in connection with the cross head of the yoke *d* as clearly indicated in Figs. 1, 2 and 4. I also provide a strong flat spring *f* which is wound on and secured to the shaft *c* centrally thereof and between the wheels or disks *e* as clearly shown in Figs. 1, 2 and 6, and said spring is also secured at *f*² to the top frame work *b*² of the car, as shown in Figs. 2, 3, 4 and 6.

Secured to the pulleys *c*² are wire ropes or cords *h* which pass downwardly through tubular keepers *h*² at the opposite sides of the car and are connected with wedge dogs *i* below the car and connected with the bottom portion of the car transversely thereof; and in the same plane as the shaft *c* is a buffer plate or bar *j*, the ends of which are beveled or wedged shaped in form as shown at *j*², and the corresponding sides of the dogs *i* are also correspondingly beveled to correspond with the plate or bar *j* or the beveled wedged shaped portions thereof as clearly shown in Fig. 1, and the wedge dogs *i* are connected with the plate or bar *j* by link devices *k* and said wedge dogs *i* are vertically movable, as will be readily understood.

At the opposite sides of the elevator shaft, and in the same plane as the shaft *c* are vertically arranged brake or lock bars *m* and the inner faces of said bars are provided in the form of construction shown in Fig. 1

with ratchet teeth m^2 and the dogs i are provided with similar teeth as shown at i^2 .

The usual car hoisting and lowering cable n is also employed and this cable is connected with yoke d and passed over the usual pulleys d^2 at the top of the elevator shaft and is connected, in practice, with the usual hoisting and lowering mechanism placed in the basement of the building, but as said hoisting and lowering mechanism forms no part in this invention it is not shown and described.

The operation will be readily understood from the foregoing description when taken in connection with the accompanying drawing and the following statement thereof. The spring f is wound on the shaft c and connected therewith in such a manner that when the cable n is connected with the yoke d and the apparatus is in operation, the car b is suspended by the cable n and the yoke d is held in an upright position, as shown in Fig. 1 and in full lines in Fig. 3. With the parts of the apparatus in this position the dogs i are suspended loosely, as shown in Fig. 1 and inwardly of the parts m , but if at any time the cable n should be broken or become disconnected in any way from the car or hoisting mechanism the spring f would at once throw the yoke d into the position indicated in dotted lines in Fig. 3, which operation would turn the shaft c and wind the ropes or cords h on the pulleys c^2 and this operation would raise the dogs i and throw them outwardly so that they would engage the bars m and the descent of the car would be instantly arrested.

In the construction shown in Fig. 7 the bars m and dogs i are provided with smooth adjacent surfaces as shown at o and with this construction the dogs i would operate as brakes or brake shoes and the descent of the car would be gradually checked instead of instantly stopped, as with the construction shown in Fig. 1, and my invention is not limited to any particular form or configuration of the adjacent surfaces of the bars m and the dogs i , and said parts may be formed in any desired manner.

The ropes or cords h are also preferably passed around or operate in connection with guide pulleys p mounted at the opposite sides of the top of the car and under or approximately under the shaft c for the purpose of guiding said ropes or cords into and through the keepers h^2 and said ropes or cords are preferably secured to the pulleys c^2 as shown at c^3 in Fig. 3, but this connection may be made in any desired manner.

In Figs. 8 to 10 inclusive, I have shown a modification of the construction shown in Figs. 1 to 7 inclusive, in which I provide supplemental devices for use in checking the descent of the car in case the hoisting mechanism should get out of order or be disabled

from any cause without breaking the cable or without the cable being broken, said devices being adapted to be operated by the party in control of the car and from within the car. These devices consist of supplemental ropes or cords r which are connected with the dogs i in the same manner as the ropes or cords h and are passed inwardly through the top portion of the opposite sides of the car and over pulleys r^2 and connected with a double sheave r^3 mounted on a shaft r^4 supported by hangers r^5 secured to the top of the car b . A spring r^6 similar to the spring f is wound on the shaft r^4 and one end of said spring is secured to said shaft and the other to the top of the car as shown at r^7 and mounted on one portion of said shaft and secured thereto is a ratchet wheel s and pivotally supported over said ratchet wheel as shown at s^2 is a depending arm s^3 having a ratchet tooth s^4 in connection with which the teeth of the ratchet wheel s operate. The shaft r^4 is angular at one end as shown at r^8 and a short crank or similar device may be applied thereto for winding the spring r^6 or any other suitable means may be provided for this purpose. The normal position of the parts when the spring r is wound up is that shown in Fig. 8 and if at any time it should become necessary to check the descent of the car while the cable is still in use the arm s^3 may be moved out of engagement with the ratchet wheel s and the spring r^6 will at once turn the shaft r^4 so as to wind the ropes or cords r on the sheave r^3 and the dogs i will be instantly thrown into operation.

It will be understood that all the features of construction shown in Figs. 1 to 7 inclusive are employed in the construction shown in Figs. 8 to 10 inclusive, and the specific forms of construction shown in Figs. 8 to 10 inclusive are supplemental to and designed to be used in connection with the construction in Figs. 1 to 7 inclusive; but it will also be understood that either form of construction may be used separately, if desired. It will also be observed that while I have shown the bars m and dogs i in Fig. 1 provided with ordinary ratchet teeth and in Fig. 7 provided with smooth engaging surfaces, I have shown these parts in Fig. 8 as provided with V-shaped teeth but as hereinbefore stated my invention is in no way limited to this feature of the construction.

My improved safety attachment for elevator cars is simple in construction and operation and comparatively inexpensive; and my invention is not limited to the exact details of construction herein shown and described and various changes therein and modifications thereof may be made, within the scope of the appended claims, without departing from the spirit of my invention or sacrificing its advantages.

Having fully described my invention what I claim as new, and desire to secure by Letters Patent is:—

1. In an apparatus of the class described, an elevator shaft, vertically arranged brake or lock bars at the opposite sides of said shaft, an elevator car movable vertically in said elevator shaft, a rotary shaft supported transversely of the top of the car, pulleys secured on the opposite ends of said shaft, a spring wound on said shaft and secured thereto and to the top framework of the car, a yoke rotatably mounted on said shaft, disks or wheels secured to said shaft and provided with pins adapted to operate in connection with the cross head of said yoke, dogs movably mounted beneath the bottom of the car and adapted to operate in connection with said brake or lock bars, and flexible devices connected with said pulleys and with said dogs.

2. In an apparatus of the class described, an elevator shaft, vertically arranged brake or lock bars at the opposite sides of said shaft, an elevator car movable vertically in said elevator shaft, a rotary shaft supported transversely of the top of the car, pulleys secured on the opposite ends of said shaft, a spring wound on said shaft and secured thereto and to the top framework of the car, a yoke rotatably mounted on said shaft, disks or wheels secured to said shaft and

provided with pins adapted to operate in connection with the cross head of said yoke, dogs movably mounted beneath the bottom of the car and adapted to operate in connection with said brake or lock bars, and flexible devices connected with said pulleys and with said dogs, said car being also provided with supplemental means adapted to be operated by hand for actuating said dogs.

3. In an apparatus of the class described, an elevator car, a shaft mounted transversely of the top thereof, pulleys connected with the opposite ends of said shaft, a spring wound on said shaft and secured thereto and one end of which is secured to the top framework of the car, a yoke rotatably mounted on said shaft, disks or wheels secured to said shaft and provided with pins adapted to operate in connection with the cross head of said yoke, laterally movable dogs mounted beneath the bottom of the car and cords connected with said pulleys and with said dogs.

In testimony that I claim the foregoing as my invention I have signed my name in presence of the subscribing witnesses this 4th day of September 1909.

JAMES H. TAYLOR.

Witnesses:

H. R. CANFIELD,
C. E. MULREANY.