

April 10, 1951

R. DOYLE

2,548,521

PIN-INSERTING FINGER BAND

Filed Sept. 17, 1946

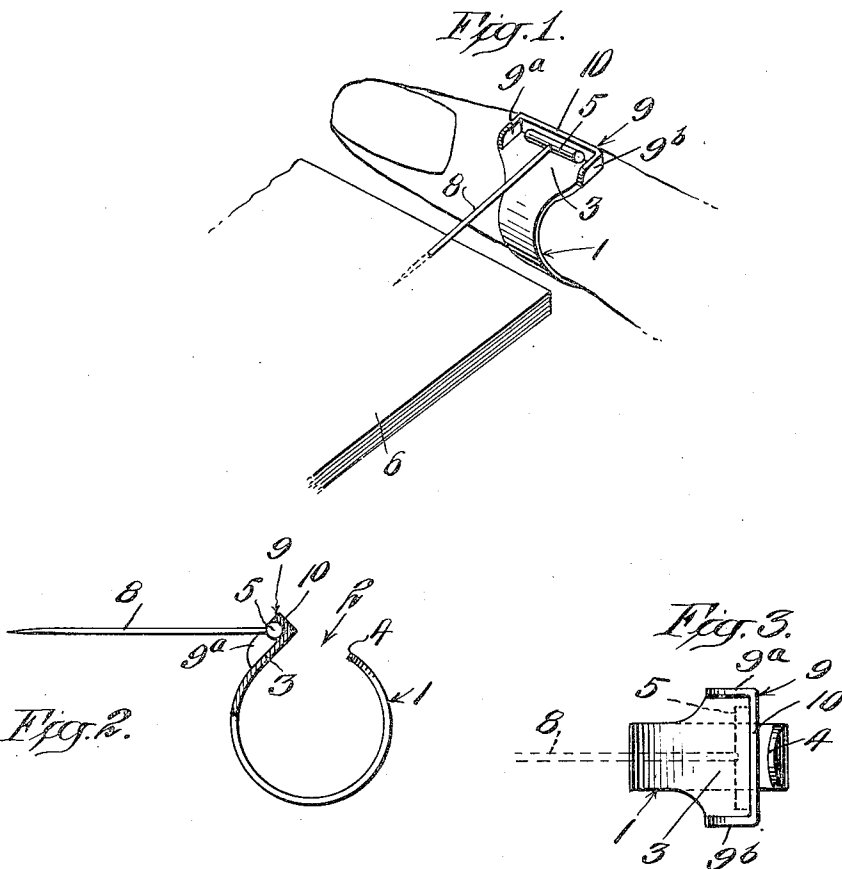

INVENTOR.
RICHARD DOYLE
BY
Julius H. Smith
ATTORNEY

UNITED STATES PATENT OFFICE

2,548,521

PIN-INSERTING FINGER BAND

Richard Doyle, Park Ridge, N. J.

Application September 17, 1946, Serial No. 697,557

2 Claims. (Cl. 81-3)

1

This invention relates to devices for inserting pins and similar articles and has for its primary object the provision of a device of this character by which pins, and particularly those of the so-called "T-shape" may be speedily and easily forced through a number of layers of paper, fabric or other material with a minimum of effort on the part of the user.

Pins of T-shape are widely used in banking institutions and in other organizations for securing together bonds, stock certificates and various papers, and are also used for fastening together samples or swatches of textile fabric, and for many other purposes. Very often the materials through which pins of this character are inserted are of tough or tenacious nature and when they are inserted through several layers or thicknesses, the insertion of the pin is resisted to such an extent as to require the imposition of considerable pressure on the headed end of the pin in order to force the pin through the materials. The result is that when a person is required to successively thrust a considerable number of these pins through materials of the kind above mentioned he soon finds that his fingers become sore and often blistered.

The principal object therefore of the present invention is to provide a device which will enable these pins to be easily and rapidly inserted, and one which will relieve the pressure and friction ordinarily imposed upon the fingers when the pins are inserted in the conventional manner.

More particularly, the invention contemplates the provision of a ring shaped device fitting about a finger of the user and provided with a seat against which the cross-bar, constituting the head of a pin of this character, is rested, the seat being provided with a surrounding flange engaging both the side or top of the head of the pin and the ends of the head of the pin, thereby positioning the head upon the seat and maintaining it from slipping therefrom while the pin is being forced through the material.

In the accompanying drawing, wherein an illustrative embodiment of the invention is disclosed, Fig. 1 is a perspective view of the device, showing the manner in which the same is fitted upon the finger and is used for the insertion of a pin; Fig. 2 is a side view of the device, with the head or seat portion therefore being shown in section, and Fig. 3 is a top plan view of the device.

The improved pin-inserting device is preferably formed from a single strip of metal, plastic or

2

other suitable material, which is bent or otherwise shaped into an open annulus or ring arranged to fit upon one of the fingers of the hand of the user, as shown in Fig. 1. The ring is open, as indicated at 2, and this opening can be contracted or spread as required to vary the internal diameter of the ring and enable it to fit fingers of various size.

One end of the ring is rounded as indicated at 4, and the other end is flared or provided with a widened part 3 constituting a seat against which the head 5 of a T-shaped pin is rested, as shown in Fig. 1, when it is desired to thrust the pin through papers 6, layers of fabric or other materials. The pin includes the head 5, in the form of a cross-bar, to which the pointed shank 8 is attached.

It will be noted that the seat 3 is provided with a laterally extending flange 9 extending around it, the end portions 9a and 9b of the flange or wall being located adjacent to the opposite ends of the head of the pin, while the central portion 10 of the flange is arranged to form an abutment for the top or side of the pin. Through this arrangement, it will be clear that the head of the pin is enclosed or embraced by the flanges and is thus maintained against slippage relatively to the seat 3 when pressure is imposed against the head of the pin in the act of thrusting the shank of the pin through the materials 6.

To use the device requires merely its placement upon the finger, usually the index finger, and by placing the seat 3 against the head of a pin to be inserted and applying relatively slight pressure thereto, the pin will be easily thrust through the materials. The surrounding flange 9, constituting a wall or abutment for the pin head, serves to properly position the head and holds it from slipping during the insertion of the pin so that the operation of inserting the pin is speedily and easily done without the imposition of strain or friction upon the fingers of the operator.

While I have shown and described one embodiment of the invention, it is obvious that the same is not to be restricted thereto, but is broad enough to cover all structures coming within the scope of the annexed claims.

What I claim is:

1. A device for inserting T-shaped pins comprising, a ring in the form of an open loop fitting about a finger of the user inwardly of the end of the finger, said ring having a widened end at least partly surrounded by a substantially U-

3

shaped flange, said end and the flange thereon constituting a seat fitting and extending partly around the cross-bar head of a T-shaped pin to enable pressure to be imposed upon said head to thrust the pin through an article.

2. A device for inserting T-shaped pins comprising, a ring fitting on a finger of the user inwardly of the end of the finger, said ring having a relatively wide and flat end portion against which the cross-bar forming the head of a T-shaped pin is rested in the act of thrusting the pin through an article, said end portion being surrounded at three sides by a flange serving to confine the head of the pin on said end portion.

RICHARD DOYLE. 15

4

REFERENCES CITED

The following references are of record in the file of this patent:

UNITED STATES PATENTS

Number	Name	Date
18,807	Devlin -----	Dec. 8, 1857
319,070	Clark -----	June 2, 1885
635,369	Bowen -----	Oct. 24, 1899
746,803	Evans -----	Dec. 15, 1903
1,522,484	Baker -----	Jan. 13, 1925
1,640,490	Dovidaitis -----	Aug. 30, 1927
2,070,078	Gitzen -----	Feb. 9, 1937
2,348,962	Davis -----	May 16, 1944