

(19) World Intellectual Property Organization  
International Bureau



(43) International Publication Date  
25 June 2009 (25.06.2009)

PCT

(10) International Publication Number  
**WO 2009/079091 A1**

- (51) **International Patent Classification:**  
A61B 17/00 (2006.01) A61B 17/068 (2006.01)  
A61B 17/064 (2006.01) A61B 17/08 (2006.01)
- (21) **International Application Number:**  
PCT/US2008/080643
- (22) **International Filing Date:** 21 October 2008 (21.10.2008)
- (25) **Filing Language:** English
- (26) **Publication Language:** English
- (30) **Priority Data:**  
11/958,281 17 December 2007 (17.12.2007) US
- (71) **Applicant (for all designated States except US):** ABBOTT LABORATORIES [US/US]; 100 Abbott Park Road, Abbott Park, IL 60064 (US).
- (72) **Inventors; and**
- (75) **Inventors/Applicants (for US only):** REYES, Steven [US/US]; 216 Carlester Drive, Los Gatos, CA 94032 (US). BARON, Scott [US/US]; 1773 W. Selby Lane, Redwood City, CA 94061 (US).
- (74) **Agents:** ROY, Fraser, D. et al.; Workman Nydegger, 60 East South Temple, 1000 Eagle Gate Tower, Salt Lake City, UT 84111 (US).
- (81) **Designated States (unless otherwise indicated, for every kind of national protection available):** AE, AG, AL, AM, AO, AT, AU, AZ, BA, BB, BG, BH, BR, BW, BY, BZ, CA, CH, CN, CO, CR, CU, CZ, DE, DK, DM, DO, DZ, EC, EE, EG, ES, FI, GB, GD, GE, GH, GM, GT, HN, HR, HU, ID, IL, IN, IS, JP, KE, KG, KM, KN, KP, KR, KZ, LA, LC, LK, LR, LS, LT, LU, LY, MA, MD, ME, MG, MK, MN, MW, MX, MY, MZ, NA, NG, NI, NO, NZ, OM, PG, PH, PL, PT, RO, RS, RU, SC, SD, SE, SG, SK, SL, SM, ST, SV, SY, TJ, TM, TN, TR, TT, TZ, UA, UG, US, UZ, VC, VN, ZA, ZM, ZW.
- (84) **Designated States (unless otherwise indicated, for every kind of regional protection available):** ARIPO (BW, GH, GM, KE, LS, MW, MZ, NA, SD, SL, SZ, TZ, UG, ZM, ZW), Eurasian (AM, AZ, BY, KG, KZ, MD, RU, TJ, TM), European (AT, BE, BG, CH, CY, CZ, DE, DK, EE, ES, FI, FR, GB, GR, HR, HU, IE, IS, IT, LT, LU, LV, MC, MT, NL, NO, PL, PT, RO, SE, SI, SK, TR), OAPI (BF, BJ, CF, CG, CI, CM, GA, GN, GQ, GW, ML, MR, NE, SN, TD, TG).
- Published:**  
— with international search report

(54) **Title:** TISSUE CLOSURE SYSTEM AND METHODS OF USE

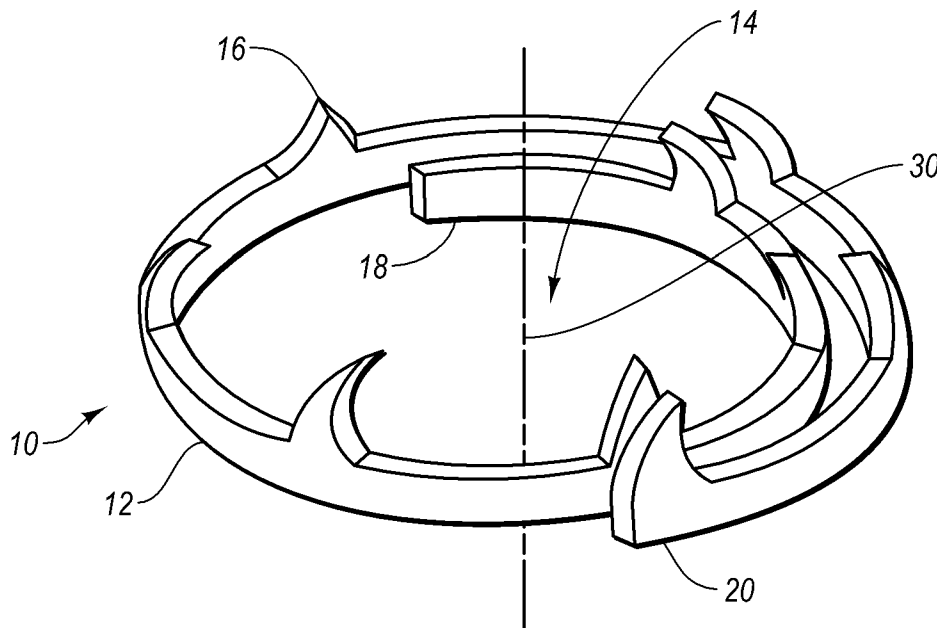

**Fig. 1A**

(57) **Abstract:** A closure element includes a coiled body and a plurality of tissue engaging portions. The tissue engaging portions disposed about at least a portion of the coiled body. The coiled body is formed of a resilient material according to one example. According to another example, a closure element includes a spiral body and a plurality of tissue engaging portions disposed about the spiral body. The spiral body is formed from a resilient material.

WO 2009/079091 A1

## TISSUE CLOSURE SYSTEM AND METHODS OF USE

### FIELD OF THE INVENTION

5 The present invention relates generally to apparatus and methods for closing and/or sealing openings through tissue, and more particularly to a closure element for closing a puncture in a blood vessel or other body lumen formed during a diagnostic or therapeutic procedure.

### 10 BACKGROUND OF THE INVENTION

Catheterization and interventional procedures, such as angioplasty or stenting, generally are performed by inserting a hollow needle through a patient's skin and tissue into the vascular system. A guidewire may be advanced through the needle and into the patient's blood vessel accessed by the needle. The needle is then removed, enabling an  
15 introducer sheath to be advanced over the guidewire into the vessel, e.g., in conjunction with or subsequent to a dilator.

A catheter or other device may then be advanced through a lumen of the introducer sheath and over the guidewire into a position for performing a medical  
20 procedure. Thus, the introducer sheath may facilitate introducing various devices into the vessel, while minimizing trauma to the vessel wall and/or minimizing blood loss during a procedure.

Upon completing the procedure, the devices and introducer sheath are removed, leaving a puncture site in the vessel wall. Traditionally, external pressure had often been applied to the puncture site until clotting and wound sealing would occur; however, the  
25 patient must remain bedridden for a substantial period of time after clotting to ensure closure of the wound. This procedure, however, may be time consuming and expensive, requiring as much as an hour of a physician's or nurse's time. It is also uncomfortable for the patient and requires that the patient remain immobilized in the operating room, catheter lab, or holding area. In addition, a risk of hematoma exists from bleeding before  
30 hemostasis occurs.

Various apparatus have been suggested for percutaneously sealing a vascular puncture by occluding the puncture site. For example, U.S. Patent Nos. 5,192,302 and 5,222,974, issued to Kensey et al., describe the use of a biodegradable plug that may be

delivered through an introducer sheath into a puncture site. Another technique has been suggested that involves percutaneously suturing the puncture site, such as that disclosed in U.S. Patent No. 5,304,184, issued to Hathaway et al.

To facilitate positioning devices that are percutaneously inserted into a blood vessel, "bleed back" indicators have been suggested. For example, U.S. Patent No. 5,676,689, issued to Kensey et al., discloses a bleed back lumen intended to facilitate positioning of a biodegradable plug within a puncture site. This device, however, requires that an anchor of the plug be positioned within the vessel, and therefore, may increase the risk of over-advancement of the plug itself into the vessel.

Alternatively, U.S. Patent No. 5,674,231, issued to Green et al., discloses a deployable loop that may be advanced through a sheath into a vessel. The loop is intended to resiliently expand in order to engage the inner wall of the vessel, thereby facilitating holding the sheath in a desired location with respect to the vessel. Accordingly, additional apparatus and methods for delivering a device for closing a vascular puncture site or other opening through tissue would be useful.

#### BRIEF SUMMARY

The present disclosure is directed to a closure element that is delivered through tissue and into an opening formed in, or adjacent to, a wall of a blood vessel or other body lumen of any size. The closure element is configured to be deployed using a clip applicator. The apparatus can be configured to receive and retain the closure element so that the closure element can be disposed substantially within the apparatus.

Other aspects and features of the present invention will become apparent from consideration of the following description in conjunction with the accompanying drawings.

#### BRIEF DESCRIPTION OF THE DRAWINGS

In order to describe the manner in which the above-recited and other advantages and features of the invention can be obtained, a more particular description of the invention will be rendered by reference to specific embodiments thereof which are illustrated in the appended drawings. Understanding that these drawings depict only typical embodiments of the invention and are not therefore to be considered to be limiting

of its scope, the invention will be described and explained with additional specificity and detail through the use of the accompanying drawings.

Fig. 1A is a perspective view of an embodiment of a closure element according to one example.

5 Fig. 1B is a top view of an embodiment of a closure element in an unexpanded state according to one example.

Fig. 1C is a top view of the embodiment of the closure element of Fig. 1B in a partially expanded state according to one example.

10 Fig. 1D is a side view of the embodiment of the closure element of Fig. 1B in an unexpanded state according to one example.

Fig. 2 is a flowchart illustrating an embodiment of a method of closing a puncture in a vessel wall according to one example.

Fig. 3 illustrates an embodiment of a closure element delivery apparatus according to one example.

15 Figs. 4A-4L illustrate various steps in the deployment of an embodiment of a closure element to close a puncture according to one example.

Fig. 5 illustrates an exploded view of an embodiment of a closure element delivery apparatus according to one example.

20 Fig. 6A-6F illustrate a tube set used to deliver an embodiment of a closure element in one example.

It should be noted that the figures are not drawn to scale and that elements of similar structures or functions are generally represented by like-reference numerals for illustrative purposes throughout the figures. It also should be noted that the figures are only intended to facilitate the description of embodiments of the present invention.

25

#### DETAILED DESCRIPTION

Embodiments described herein extend to methods, systems, and apparatus for closing and/or sealing openings in a blood vessel or other body lumen formed during a diagnostic, therapeutic, and/or other procedure. The closure elements of the present invention may be configured to be delivered through tissue and into an opening formed in and/or adjacent to a wall of a blood vessel or other body lumen. The closure elements provided herein may reliably engage.

30

Figs. 1A-1D illustrate an embodiment of a closure element 10. The closure element (also referred to herein as a “clip”) 10 can have a generally annular-shaped body 12 defining a channel 14. The channel 14 may include an axis 30. In the present embodiment, the axis 30 may be a central axis. In other embodiments, the axis 30 may be a non-central axis. The closure element 10 may include one or more barbs and/or tines 16 for receiving and engaging tissue (a blood vessel wall for example). The tines 16 in the present embodiment may be disposed about the periphery of the body 12. Although the closure element 10 may have a natural shape and size, the closure element 10 can be deformed into other shapes and sizes, as desired, and may be configured to return to the natural shape and size when released. For example, the closure element 10 can have a natural, planar configuration with a relaxed cross-section as shown in Figs. 1A and 1B.

The closure element 10 can be formed from any suitable material, including any biodegradable and/or bioreabsorbable material, any shape memory alloy, such as alloys of nickel-titanium, or any combination thereof. Such configurations may allow the closure element 10 to draw an opening in tissue substantially closed and/or to enhance hemostasis within the opening. Additionally, it is contemplated that the closure element may be coated with a beneficial agent and/or be constructed as a composite, wherein one component of the composite may include a beneficial agent. As desired, the closure element 10 may further include radiopaque markers (not shown) or may be wholly or partially formed from a radiopaque material to facilitate observation of the closure element 10 using fluoroscopy or other imaging processes.

In one example, the closure element 10 may be formed by etching and/or cutting the tines or other attachment features into the body 12. The body may be a thin sheet of material. The sheet may then be moved (i.e. rolled or otherwise set) to a relaxed position and heat treated.

The closure element 10 may include a first end 18 and a second end 20 separated by the body 12. The length of the closure element 10 may generally define a spiral that, when in a relaxed state, may coil to form between a portion of a single coil (i.e. a partial coil) to multiple coils. In particular, as seen from above in Fig. 1B the closure element 10 may form a curve on a plane that winds around a center point P and increases in distance from point P. In one example, the spiral may begin at the first end 18 that may be a radial distance  $R_{RS1}$  from the center point P and may extend toward the second end 20 that may be a radial distance  $R_{RS2}$  from the center point P. The first end 18 and second end 20 may be separated by an angular separation  $AS_{RS}$  that may be less than, equal to, or greater than

360 degrees. In the present embodiment, the angular separation  $AS_{RS}$  between the first end 18 and the second end 20 in the relaxed state may be about 180 degrees.

In a partially expanded state, such as that shown in Fig. 1C, the angular separation  $AS_{ES}$  may approach 0 degrees. In other embodiments, the angular separation  $AS_{ES}$  in the partially expanded state may approach another angular measurement. In the present embodiment, the angular separation  $AE_{RS}$  may decrease from about 180 degrees in the relaxed state towards the angular separation  $AE_{ES}$  of about 0 degrees in the expanded state.

In the present embodiment, a radial distance  $R_{ES1}$  from the center point P to the first end 18 may increase relative to the radial distance  $R_{RS1}$  from the center point P to the first end 18 a relaxed state (Fig. 1B). A radial distance  $R_{ES2}$  from the center point P to the second end 20 may increase relative to the radial distance  $R_{RS2}$  from the center point P to the second end 20 a relaxed state (Fig. 1B). As the radial distances  $R_{RS1}$ ,  $R_{RS2}$ ,  $R_{ES1}$ ,  $R_{ES2}$  increase, the angular separation of the closure element 10 may decrease. In other words, in a deflected state the coiling formed by the closure element 10 may be loosened.

The closure element 10 may be formed of a resilient material. As a result, while in a deflected state (i.e. an expanded state), a biasing force may act on the closure element 10 to return the closure element 10 toward an undeflected state (i.e. a relaxed state). This biasing force may act to tighten the coiling of the closure element 10, while drawing the closure element 10 simultaneously radially inward.

The tightening of the closure element 10 may be used to close a puncture in tissue, as will now be discussed. One general method of deploying closure element 10 will first be introduced followed by a discussion of the use of an apparatus configured to deploy the closure element 10.

Fig. 2 illustrates an embodiment of a method of closing an opening in tissue (i.e. a vessel wall or other tissue). A sheath may be introduced, as represented by block 50. The sheath may be oriented to facilitate the introduction of devices through the sheath and through tissue (i.e. into a blood vessel) with minimal risk of damage to the tissue. These devices may be used to perform a therapeutic and/or diagnostic procedure, such as angioplasty, atherectomy, stent implantation, and the like, within the patient's vasculature.

A clip applicator apparatus, such as the clip applicator apparatus shown in Fig. 3, may be prepared to deploy a closure element 10 (Figs. 1A-1D), as represented by block 60. The clip applicator apparatus may be located relative to the tissue (i.e. relative to the vessel),

as represented by block 70. In one example, the clip applier apparatus may be guided through the tissue by the sheath.

The closure element may be delivered, as represented by block 80. Delivering the closure element may include closing the opening in the tissue (i.e. the vessel wall). The clip applier apparatus may be withdrawn, as represented by block 90. This brief  
5 description of the deployment process provides an introduction to the processes described below for context. More or fewer steps may be performed in closing an opening through tissue.

Fig. 3 illustrates an embodiment of a clip applier apparatus 100 that may be used  
10 to apply the closure element 10 (Figs. 1A-1D). The clip applier apparatus 100 may include a number of assemblies or groups, which may include a locator assembly 200, a carrier assembly 300, and/or a triggering system 400. These assemblies may cooperate to position the closure element 10 through a process similar to that described above with reference to Fig. 2. The clip applier apparatus 100 can be provided as one or more  
15 integrated components and/or discrete components. For purposes of illustration, the locator assembly 200 and the carrier assembly 300 are shown in Fig. 3 as substantially separate assemblies. As desired, however, the locator assembly 200 and the carrier assembly 300 each can be provided, in whole or in part, as one or more integrated assemblies.

20 The clip applier apparatus 100 can deliver a closure element 10 (Fig. 1A-1D) to an opening in tissue. In particular, the closure element 10 may be delivered into an opening formed in and/or adjacent to a wall of the blood vessel or other body lumen. When properly positioned, the clip applier apparatus 100 can be activated to deploy the closure element 10.

25 Turning now to Fig. 4A, the clip applier apparatus 100 (Fig. 3) discussed above will now be discussed in the context of a patient and with respect to a blood vessel 600. The blood vessel 600 has a vessel wall 620 with an outer portion 620a and an inner portion 620b. The clip applier apparatus 100 may then be used to apply the closure element 10.

30 In particular, a sheath 640 may be inserted or otherwise positioned through skin 650 and tissue 630 and within the blood vessel 600 or other body lumen via an opening 610. The sheath 640 can include a substantially flexible or semi-rigid tubular member. Also, the sheath 640 can have a proximal end region 640a and a distal end region 640b. The sheath 640 may further have a predetermined length and a predetermined cross-

section, both of which can be of any suitable dimension. The sheath 640 also can form a lumen 644 that extends along a longitudinal axis of the sheath 640 and substantially between the proximal and distal end regions 640a, 640b. The lumen 644 can have any suitable internal cross-section 644b and is suitable for receiving one or more devices (not shown), such as a catheter, a guidewire, or the like.

The sheath 640 may be advanced over a guidewire or other rail (not shown) which may have been positioned through the opening 610 and into the blood vessel 600 using conventional procedures. The blood vessel 600 can be a peripheral blood vessel, such as a femoral or carotid artery, although other body lumens may be accessed using the sheath 640. The opening 610, and consequently the sheath 640, may be oriented with respect to the blood vessel 600 such as to facilitate the introduction of devices through the lumen 644 of the sheath 640 and into the blood vessel 600 with minimal risk of damage to the blood vessel 600. One or more devices (not shown), such as a catheter, or the like, may be inserted through the sheath 640 and advanced to a preselected location within the patient's body. For example, the devices may be used to perform a therapeutic and/or diagnostic procedure, such as angioplasty, atherectomy, stent implantation, and the like, within the patient's vasculature.

After the procedure is completed, the devices may be removed from the sheath 640. The clip applicator apparatus 100 may be prepared to be received by the lumen 644 of the sheath 640 as shown in Fig. 4B. The locator assembly, 200 may include a tubular body 210 having a distal end region 210b. Being in the unexpanded state, the distal end region 210b of the tubular body 210 of the locator assembly 200 can be slidably received by the lumen 644 and atraumatically advanced distally into the blood vessel 600 as illustrated in Figs. 4B-4C. Advancing the distal end region 210b into the lumen 644 begins the location of the locator assembly 200 relative to the blood vessel 600.

Once the distal end region 210b of the tubular body 210 extends into the blood vessel 600, the distal end region 210b may transition from the unexpanded state to the expanded state as shown in Fig. 4D when the triggering system 400 (Fig. 3) of the locator assembly 200 is activated.

Turning to Fig. 4E, the apparatus 100 and the sheath 640 may be retracted proximally until the distal end region 210b is substantially adjacent to an inner surface 620b of the blood vessel wall 620. The distal end region 210b thereby may draw the blood vessel wall 620 taut and may maintain the proper position of the apparatus 100 as the blood vessel 600 pulsates. Since the expanded cross-section of the distal end region



210b can be greater than or substantially equal to the cross-section of the opening 610 and/or the cross-section of the lumen 644, the distal end region 210b may remain in the blood vessel 600 and may engage the inner surface 620b of the blood vessel wall 620. The distal end region 210b may frictionally engage the inner surface 620b of the blood vessel wall 620, thereby securing the apparatus 100 to the blood vessel 600. The sheath 640 can be retracted proximally such that the distal end region 640b of the sheath 640 may be substantially withdrawn from the blood vessel 600, as shown in Fig. 4E, permitting apparatus 100 to access the blood vessel wall 620.

Once the distal end region 210b of the locator assembly 200 contacts the inner surface 620b of the blood vessel wall 620, a distal portion 300b of the carrier assembly 300 may be advanced distally and may be received within the lumen 644 of the sheath 640 as illustrated in Fig. 4F. The sheath 640 may radially expand and/or split in accordance with the predetermined pattern as the distal portion advances because the internal cross-section 644b of the sheath 640 may be less than an outer portion carrier assembly 300. Once the carrier assembly 300 is located adjacent the outer surface 620a of the blood vessel wall 620, the carrier assembly 300 may be deployed.

The carrier assembly 300 may include a pusher member 320, a cover member 330, and a support member 340 that may be coupled together. Accordingly, the carrier member 310, the pusher member 320, the cover member 330, and the support member 340 may each advance distally and may approach a predetermined position as illustrated in Fig. 4G.

Upon reaching the first predetermined position, the distal portion 300b of the carrier assembly 300 can be disposed substantially adjacent to the outer surface 620a of the blood vessel wall 620 adjacent to the opening 610 such that the blood vessel wall 620 adjacent to the opening 610 may be disposed substantially between the expanded distal region 210b of the locator assembly 200 and the distal portion of the carrier assembly 300. The cover member 330 and the support member 340 can each decouple from the carrier member 310 and the pusher member 320 when the tube set 305 is in the first predetermined position. The cover member 330 and the support member 340 can be inhibited from further axial movement and remain substantially stationary as the carrier member 310 and the pusher member 320 each remain coupled and axially slidable.

As shown in Figs. 4H-4L, the cover member 330 and the support member 340 can remain substantially stationary while the carrier member 310 and the pusher member 320 can continue distally and approach a second predetermined position. As the carrier

member 310 and the pusher member 320 distally advance toward the second predetermined position, an annular cavity 370 (Fig. 4G) can move distally relative to the substantially-stationary cover member 330 such that the distal end region 330b of the cover member 330 no longer encloses the annular cavity 370.

5 As a result, the closure element 10 may not be completely enclosed by the annular cavity 370 formed by the distal end regions 310b, 320b, and 330b of the carrier member 310, the pusher member 320, and the cover member 330. Although not completely enclosed by the annular cavity 370, the closure element 10 can be advantageously retained on the outer periphery of the carrier member 310 by the distal end region 330b of  
10 the cover member 330 as illustrated in Fig. 4H. For example, by retaining the closure element 10 between the distal end region 330b of the cover member 330 and the distal end region 310b of the carrier member 310, the apparatus 100 can be configured to provide better tissue penetration. The timing between the deployment of the closure element 10 by the tube set 305 and the retraction and transition to the unexpanded state by  
15 the locator assembly 200 likewise may be facilitated because the closure element 10 may be retained between the distal end region 330b of the cover member 330 and the distal end region 310b of the carrier member 310. Further, the carrier member 310 and the cover member 330 can operate to maintain the closure element 10 in the tubular configuration.

20 As shown in Figs. 4H-4L, the closure element 10 may be deployed. The closure element 10 may engage the vessel wall 620 (as shown in Fig. 4J) in the partially expanded state. For example, the tissue engaging portions 16 (Fig. 4K) may frictionally, piercingly, and/or otherwise engage the vessel wall 620. The radial distances (not shown) of the first and second ends (not shown) of the closure element 10 may change in size  
25 and/or the angular position (not shown) of the first and second ends may change (i.e. decrease). The change in the size of the radial distances and/or angular positions of the first and second ends of the closure element 10 may substantially close the opening 610 in the vessel wall 620.

Fig. 5 is an exploded view of the embodiment of a clip applier apparatus 100 of  
30 Fig. 3. The locator assembly 200 may be configured to draw the blood vessel wall 620 taut and/or maintain the proper position of the clip applier apparatus 100 in relation to the opening 610 as the blood vessel 600 pulsates (Figs. 4E-4I). The locator assembly 200 may be provided in the manner disclosed in U.S. Patent Nos. 6,780,197 and 6,942,674, the disclosures of which are expressly incorporated herein by reference. The locator

assembly 200 can include a flexible or semi-rigid tubular body 210. As illustrated in Fig. 5, the tubular body 210 may include a proximal end region 210a and a distal end region 210b and may include a predetermined length and/or a predetermined outer cross-section, both of which can be of any suitable dimension. The distal end region 210b of the locator  
5 assembly 200 can include a substantially rounded, soft, and/or flexible distal end or tip 220 to facilitate atraumatic advancement and/or retraction of the distal end region 210b into tissue (i.e. the blood vessel 600). As desired, a pigtail (not shown) may be provided on the distal end 220 to further aid atraumatic advancement of the distal end region 210b.

The distal end region 210b of the locator assembly 200 further can be selectably  
10 controllable between an unexpanded state and an expanded state. In the unexpanded state, the distal end region 210b may have an unexpanded size; whereas, the distal end region 210b in the expanded state may have an expanded size, which may be greater than the unexpanded size of the distal end region 210b in the unexpanded state. The distal end region 210b can be configured to expand and/or contract from the unexpanded size to the  
15 expanded size to the unexpanded size. The expansion and contraction of the distal end region 210b can be substantially uniform about a longitudinal axis of the locator assembly 200. For example, one or more expansion elements 230 can be provided on the distal end region 210b and can be configured to expand substantially transversely with respect to a longitudinal axis of the locator assembly 200. In one configuration, being substantially  
20 equally distributed about an outer periphery of the distal end region 210b, the expansion elements 230 may include radiopaque markers (not shown) or may be wholly or partially formed from a radiopaque material to facilitate observation of the expansion elements 230 and/or the distal end region 210b using fluoroscopy or other imaging systems. The distal end region 210b is shown in its expanded state, wherein the expansion elements 230 are  
25 flexed outward.

Continuing with reference to Fig. 5, a control member 250, such as a rod, wire, or other elongate member, can be moveably disposed within a lumen (not shown) formed by the tubular body 210 and may extend substantially between the proximal end region 210a and the distal end region 210b. The control member 250 can have a proximal end region  
30 that may be coupled with a control block 260 and a distal end region that may be coupled with the distal end region 210b of the locator assembly 200 and/or the expansion elements 230. The control block 260 can be a tubular shape and may be formed of a metal and/or rigid plastic. The control block 260 may be adapted to be retained in the housing bottom half 380 to maintain the control block 260 in a substantially fixed position relative to the

housing 380. The locator assembly 200 can selectively transition the distal end region 210b, the expansion elements 230, and/or the substantially flexible members 230 between the unexpanded and expanded states by moving the tubular body 210 axially relative to the control member 250.

5           The tubular body 210 can have a tubular body block 270. The tubular body block 270 can be formed of metal, rigid plastic, or other substantially rigid material and may sometimes be formed integrally with or attached securely to the tubular body 210. The proximal end of the tubular body block 270 can have a shape adapted to cooperate with a locator assembly block 280 whereby the tubular body block 270 may be maintained in a  
10 fixed axial relationship with the locator assembly block 280. In this manner, the tubular body block 270 and tubular body 210 can be advanced distally by distal advancement of the locator assembly block 280.

          A locator assembly spring 290 can be located coaxially with and/or substantially surround a portion of the tubular body block 270. The locator assembly spring 290 can  
15 be located so as to provide a force biasing the locator assembly block 280 in the proximal direction relative to the housing 380.

          The locator assembly block 280 can be formed of metal, plastic, and/or other substantially rigid material. A function of the locator assembly block 280 can allow the user to apply a force causing distal movement of the tubular body 210 relative to the  
20 control member 250 to cause the locator assembly 200 to transition from the unexpanded state to the expanded state.

          The clip applicer apparatus 100 may include a triggering system 400 that can be disposed substantially within the housing 380 (illustrated assembled in Fig. 3). The triggering system 400 can be configured to control the relative axial movement and/or  
25 positioning of the respective distal end regions 310b, 320b, 330b, and 340b of the tube set 305 and/or the distal end region 210b of the locator assembly 200. The triggering system 400 may be coupled to proximal end regions 210a, 310a, 320a, 330a, and/or 340a to control the relative axial movement of the distal end regions 210b, 310b, 320b, 330b, and/or 340b in any manner, such as by being activated by a switching system. As  
30 desired, the triggering system 400 can induce axial motion, such as distal motion, with respect to one or more of the distal end regions 210b, 310b, 320b, 330b, and/or 340b. One or more of the distal end regions 210b, 310b, 320b, 330b, and/or 340b can be axially moved. Axial motion of one or more of the carrier member 310, the pusher member 320, the cover member 330, and the support member 340 and/or the tubular body 210 can be

attained, for example, by applying an axial force to the switching system 450. To facilitate monitoring of the positioning of the carrier assembly 300 and/or closure element 10, one or more of the distal end regions 210b, 310b, 320b, 330b, and/or 340b may include radiopaque markers (not shown) or may be wholly or partially formed from a radiopaque material. The discussion of several parts specific to the example illustrated will be omitted for clarity in describing the operation of the clip applier apparatus 100 in delivering the closure element 10. Additional details of some exemplary triggering systems are found in United States Patent Application, Serial No. 11/427,297, entitled "Clip Applier and Methods of Use", and filed June 28, 2006, which is hereby incorporated by reference in its entirety.

The triggering system 400 can be configured to overcome internal resistance such that the relative axial movement and/or positioning of the respective distal end regions 310b, 320b, 330b, and 340b of the tube set 305 and/or the distal end region 210b of the locator assembly 200 may be controlled in accordance with a predetermined manner when the triggering system 400 is activated. Movement and/or positioning of the distal end regions 310b, 320b, 330b, 340b, and/or 210b can be initiated when at least a predetermined quantity of force is applied to the switching system 450. Stated somewhat differently, a force that is less than the predetermined quantity generally may be insufficient to activate the triggering system 400; whereas, when the force increases to a level that is greater than or substantially equal to the predetermined quantity, the triggering system 400 may be configured to activate, move, and/or position the distal end regions 310b, 320b, 330b, 340b, and/or 210b in accordance with the predetermined manner. The triggering system 400, once activated, can continue to move and/or position the distal end regions 310b, 320b, 330b, 340b, and/or 210b in accordance with the predetermined manner until the closure element 10 is deployed.

The triggering system 400, for example, can include one or more sets of cooperating detents for coupling the axial motion of the distal end regions 310b, 320b, 330b, and 340b in accordance with a predetermined manner when the triggering system 400 is activated. The term "detents" refers to any combination of mating elements, such as blocks, tabs, pockets, slots, ramps, locking pins, cantilevered members, support pins, and the like, that may be selectively or automatically engaged and/or disengaged to couple or decouple the carrier member 310, the pusher member 320, the cover member 330, and the support member 340 relative to one another. The cooperating detents as illustrated and described herein are merely exemplary and not exhaustive. For example,

the cooperating detents can include a first set of cooperating blocks and pockets for releasably coupling the support member 340, the carrier member 310, the pusher member 320, and/or the cover member 330. When the carrier assembly 300 reaches a first predetermined distal position, the support member 340 can be decoupled from the carrier member 310, the pusher member 320, and/or the cover member 330 and can be substantially inhibited from further axial movement. As a result, the carrier member 310, the pusher member 320, and/or the cover member 330 may continue to be directed distally as the support member 340 remains substantially stationary.

The triggering system 400 can further include one or more stops for engaging the pusher block 420, the cover block 430, and/or the support block 440, respectively. When an axial force is applied to the tube set 305 via the switching system 450, the cover block 430 can move distally within the housing 380 until the cover block 430 is substantially locked in place, substantially preventing any further motion of the cover block 430. The triggering system 400 may further include a tube release system for inhibiting inadvertent advancement of the tube set 305 and a locator release system 490 for permitting the distal end region 210b, the expansion elements 230, and/or the substantially flexible members 230 of the locator assembly 200 to transition from the expanded state to the unexpanded state can be included with the triggering system 400. The carrier assembly 300 (Fig. 3) can be coupled with, and slidable relative to, the locator assembly 200. The carrier assembly 300 can include a tube set that includes a carrier member 310, a pusher member 320, a support tube 340, and/or a cover member 330.

As illustrated in Fig. 6A, the carrier member 310, the pusher member 320, the support tube 340, and the cover member 330 can be provided as a plurality of nested, telescoping members with a common longitudinal axis 350. This may allow the carrier member 310 to be at least partially disposed within, and slidable relative to, the lumen 334 of the pusher member 320 as shown in Fig. 6C. The pusher member 320, in turn, can be at least partially disposed within, and slidable relative to, the lumen 334 of the cover member 330. To couple the carrier assembly 300 with the locator assembly 200 (Fig. 5), the tubular body 210 of the locator assembly 200 can be at least partially disposed within, and slidable relative to, the lumen 314 of the carrier member 310. The longitudinal axis of the locator assembly 200 can be substantially in axial alignment with the common longitudinal axis 350 of the carrier member 310, the pusher member 320, the cover member 330, and the support tube 340.

The tube set 305 can also include a support member 340. The support member 340 may be configured to slidably receive the tubular body 210 of the locator assembly 200 and/or to provide radial support for the distal end region 210b of the tubular body 210 when the locator assembly 200 is coupled with the carrier assembly 300. The carrier assembly 300 can advantageously include the support member 340, for example, if the tubular body 210 is not sufficiently rigid or under other circumstances in which support for the tubular body 210 might be desirable. The support member 340 can be configured to inhibit the plurality of longitudinal extensions 335, which may extend from the distal end region 330b of the cover member 330, from expanding prematurely prior to the closure element 10 being deployed.

The support member 340 can be formed as a substantially rigid, semi-rigid, or flexible tubular member, having a proximal end region 340a and a distal end region 340b. An outer periphery 342b of the support member 340 can define a lumen 344 that extends substantially between the proximal end region 340a and the distal end region 340b, the lumen 344 may be configured to slidably receive and support at least a portion of the tubular body 210 of the locator assembly 200. The support member 340, in turn, can be at least partially slidably disposed within the lumen 314 of the carrier member 310 such that the tubular body 210 of the locator assembly 200 may be coupled with, and/or slidable relative to, the carrier member 310. The support member 340 can have a predetermined length and/or a predetermined cross-section, both of which can be of any suitable dimension, and the cross-section can be substantially uniform. Although shown and described as being substantially separate for purposes of illustration, it will be appreciated that the carrier member 310, the pusher member 320, the cover member 330, and/or the support member 340 can be provided, in whole or in part, as one or more integrated assemblies.

In operation, the distal end region 210b of the locator assembly 200 may be positioned as desired and transitioned from the unexpanded state to the expanded state. While the locator control system the distal end region 210b is in the expanded state, a distally-directed axial force can be applied to the triggering system 400 via the switching system 450. The pusher block 420 may then be freed to allow the tube set 305 to slide within the housing 380 distally from an initial predetermined position to a first predetermined position.

In the initial predetermined position, the carrier member 310, the pusher member 320, the cover member 330, and/or the support member 340 can be coupled such that the

carrier block 410, the pusher block 420, the cover block 430, and/or the support block 440 may be coupled. As a result, the carrier member 310, the pusher member 320, the cover member 330, and/or the support member 340 each can slide distally from the initial predetermined position to the first predetermined position in response to the axial force.

5 To continue distally from the first predetermined position, the carrier member 310 and the pusher member 320 can be decoupled from the cover member 330 and the support member 340. The carrier member 310 and the pusher member 320 remain coupled with the cover member 330 and the support member 340. As the axial force increases to a level that is greater than or substantially equal to the combined static force  
10 between the components, the carrier member 310 and the pusher member 320 may become uncoupled from the cover member 330 and the support member 340 thereby allowing the carrier member 310 and the pusher member 320 to proceed distally toward a second predetermined position.

In the second predetermined position, the carrier block 410 can engage the carrier  
15 stop 460c. Whereby, the carrier stop 460c can receive, and substantially inhibit further movement of, the carrier block 410 and, therefore, the carrier member 310. To continue distally from the second predetermined position, the pusher member 320 can be decoupled from the carrier member 310.

As the axial force increases to a level that is greater than or substantially equal to  
20 the static force, the pusher member 320 may be decoupled from the carrier member 310 allowing the pusher member 320 to proceed distally to deploy the closure element 10 and to activate a locator release system 490 such that the distal end region 210b, the expansion elements 230, and/or the substantially flexible members 230 of the locator assembly 200 transition from the expanded state to the unexpanded state. The axial force  
25 that is applied to overcome the static force associated with the first predetermined position can be sufficient to overcome the static forces associated with the subsequent predetermined positions, to deploy the closure element 10, and to activate the locator release system 490 such that the triggering system 400 may operate in one substantially-continuous motion.

30 The triggering system 400 can include an energy storing element (not shown), which can be disposed substantially between the housing 380 and the blocks 410, 420, 430, and 440 and which can be configured to store potential energy for moving the tube set 305 from the initial predetermined position through the other predetermined positions, deploying the closure element 10, and/or activating the locator release system 490. The



energy-storing element can be configured store the potential energy when the tube set 305 is in the initial predetermined position and to release the potential energy, when activated, such that the tube set 305 may travel through the predetermined positions at a substantially constant and continuous rate. For example, the energy-storing element can include one or more springs (not shown). Each of the springs can be in a compressed state when the tube set 305 is in the initial predetermined position and may be released from the compressed state when the switching system 450 of the triggering system 400 is activated.

When the apparatus 100 is properly assembled, the tubular body 210 of the locator assembly 200 can be at least partially disposed within the tube set 305 of the carrier assembly 300 such that the distal end region 210b of the tubular body 210 may extend beyond the distal end regions 310b, 320b, 330b, and/or 340b. One example of an assembled tube set is illustrated in Fig. 6A. Further, the proximal end region 210a of the tubular body 210 and the proximal end regions 310a, 320a, 330a, and/or 340a of the tube set 305 are at least partially disposed within, and slidable relative to, the housing 380.

Fig. 6B illustrates the carrier member 310 in more detail. The carrier member 310 can be configured to receive and/or support the closure element 10. While being disposed on the carrier member 310, the closure element 10 can be deformed from the natural, relaxed configuration (shown in Figs. 1B and 1D) to a deflected or expanded state (shown in Fig. 1C).

Fig. 6B illustrates how the closure element 10 may be disposed substantially about, and/or supported by, an outer periphery 312b of the carrier member 310. The closure element 10 can be substantially in axial alignment with the carrier member 310 with the tines 16 pointed substantially distally.

In one configuration, the carrier member 310 can be formed as a substantially rigid, semi-rigid, or flexible tubular member. The carrier member 310 can have a proximal end region 310a and a distal end region 310b and can include a predetermined length 318a and/or a predetermined cross-section 318b, both of which can be of any suitable dimension. The carrier member 310 also can define a lumen 314 that may extend substantially between the proximal end region 310a and the distal end region 310b and that may be configured to slidably receive at least a portion of the tubular body 210 of the locator assembly 200. Although the cross-section 318b of the carrier member 310 generally is substantially uniform, the distal end region 310b of the carrier member 310 may have a cross-section that increases distally, as illustrated in Figs. 6A-6B, for

substantially uniformly expanding the closure element 10 when the closure element 10 is deployed.

To deploy the closure element 10 without expanding the closure element 10 prior to deployment, the distal end region 310b can be formed with a cross-section (not shown) that is substantially uniform. Although shown and described as having the cross-section that increases distally for expanding the closure element 10, it will be understood that the distal end region 310b of the carrier member 310 may be provided with the substantially-uniform cross-section and that the closure element 10 may be deployed without being expanded prior to deployment.

Fig. 6C illustrates the pusher member 320 in more detail. The pusher member 320 may be configured to distally deploy the closure element 10. In particular, the pusher member 320 may include a proximal end region 320a and a distal end region 320b. In addition, the pusher member 320 may be coupled with and slidable relative to the carrier member 310. The pusher member 320 may include a predetermined length 328a and/or a predetermined cross-section 328b, both of which may be of any suitable dimension and may be configured to slidably receive the carrier member 310 such that the distal end region 320b of the pusher member 320 may be offset proximally from the distal end region 310b of the carrier member 310. As desired, the predetermined length 328a of the pusher member 320 can be greater than or substantially equal to the predetermined length 318a of the carrier member 310. The predetermined length 328a of the pusher member 320, however, may be less than the predetermined length 318a of the carrier member 310 such that the carrier member 310 and the pusher member 320 may at least partially define a space 370 distal to the distal end region 320b of the pusher member 320 and along the periphery 312b of the carrier member 310.

In Fig. 6D, the closure element 10 is shown disposed on the carrier member 310. As the carrier member 310 is received within the pusher member 320, the distal end 320b of the pusher member 320 may be urged distally. Thereby, reducing the distance between the distal end 320b of the pusher member 320 and the distal end 310b of the carrier member 310. At some point, the distal end 320b of the pusher member 320 may come into contact with the closure element 10. Thereafter, further advancing the pusher member 320 may urge the closure element 10 toward the distal end 310b of the carrier member 310.

The cross-section 328b of the pusher member 320 can be substantially uniform and the distal end region 320b of the pusher member 320 can include one or more

longitudinal extensions 325, which may extend distally from the pusher member 320 and along the periphery 312b of the carrier member 310 as shown in Fig. 6C. The longitudinal extensions 325 can be biased such that the longitudinal extensions 325 may extend generally in parallel with common longitudinal axis 350. The longitudinal extensions 325 may be sufficiently flexible to expand radially, and yet sufficiently rigid to inhibit buckling, as the distal end region 320b is directed distally along the carrier member 310 and engages the distally-increasing cross-section of the distal end region 310b of the carrier member 310 to deploy the closure element 10.

Fig. 6E illustrates the cover member 330 in more detail. A cover member 330 may be configured to retain the closure element 10 (best shown in Fig. 6A) substantially within the carrier assembly 300 prior to deployment as shown in Fig. 6D. Being coupled with, and/or slidable relative to, the pusher member 320, the cover member 330 may include a proximal end region 330a and/or a distal end region 330b and may include a predetermined length 338a and/or a predetermined cross-section 338b, both of which can be of any suitable dimension.

The cover member 330 can be formed as a substantially rigid, semi-rigid, or flexible tubular member. The cover member 330 can have an inner periphery 332a and/or an outer periphery 332b and/or can define a lumen 334. The lumen 334 can extend substantially between the proximal and distal end regions 330a, 330b of the cover member 330 and/or can be configured to slidably receive at least a portion of the pusher member 320. When the cover member 330 is properly positioned within the carrier assembly 300, the distal end region 330b can be configured to extend over the space 360, to provide space for receiving and retaining the closure element 10. The cross-section 338b of the cover member 330 can be substantially uniform. The distal end region 330b of the cover member 330 can include one or more longitudinal extensions 335, which may extend distally from the cover member 330 and along an outer periphery 322b of the pusher member 320 as shown in Fig. 6D.

Turning again to Fig. 6A, although the longitudinal extensions 335 can extend generally in parallel with common longitudinal axis 350, the longitudinal extensions 335 can be biased such that the plurality of longitudinal extensions 335 extend substantially radially inwardly. The inward extension of the longitudinal extensions 335 can partially close the lumen 334 substantially adjacent to the distal end region 330b (Fig. 6D) of the cover member 330. The longitudinal extensions 335 can be sufficiently flexible to expand radially to permit the distal end region 310b (Fig. 6E) of the carrier member 310

to move distally past the cover member 330 such that the distal end region 330b no longer extends over the space 360. As the carrier member 310 moves past the distal end region 330b, the carrier member 310 may move the closure element 10 toward deployment.

5 The invention is susceptible to various modifications and alternative means, and specific examples thereof have been shown by way of example in the drawings and are herein described in detail. It should be understood, however, that the invention is not to be limited to the particular devices or methods disclosed, but to the contrary, the invention is to cover all modifications, equivalents, and alternatives falling within the spirit and scope of the claims.

10

## CLAIMS

We claim:

1. A closure element, comprising:  
a coiled body; and  
5 a plurality of vessel engaging elements disposed about at least a portion of said coiled body, said coiled body being formed of a resilient material.
2. The closure element of claim 1, wherein said coiled body forms more than one coil when in said coiled body is in a relaxed state.  
10
3. The closure element of claim 1, wherein said resilient material includes at least one of a biodegradable material, a bioreabsorbable material, and a shape memory alloy.
- 15 4. The closure element of claim 1, wherein said coiled body includes a first end and a second end separated by an angular separation, said angular separation corresponding to a relaxed state being greater than an angular separation corresponding to an expanded state.
- 20 5. The closure element of claim 1, wherein a radial distance of said coiled body in a relaxed state is less than a radial distance of said coiled body in an expanded state.
6. The closure element of claim 1, wherein said vessel engaging feature  
25 includes at least one tine.
7. A closure element, comprising:  
a spiral body; and  
a plurality of tissue engaging portions disposed about said spiral body, said  
30 spiral body being formed from a resilient material.
8. The closure element of claim 7, said spiral body being configured to contract from a partially expanded state to a relaxed state to close an opening in tissue.

9. The closure element of claim 8, wherein said spiral body includes a first end and a second end separated by an angular separation, said angular separation increasing as the spiral body contracts.

5 10. The closure element of claim 8, wherein said spiral body is further configured to contract radially relative to an axis of said closure element.

11. The closure element of claim 7, wherein said tissue engaging portions include a plurality of tines.

10

12. The closure element of claim 7, wherein said spiral body includes a proximal end and a distal end, said tissue engaging portions being formed on a distal end of said spiral body.

15 13. The closure element of claim 12, wherein said proximal end is generally planar.

14. The closure element of claim 12, wherein said closure element is formed from at least one of a biodegradable material, a bioreabsorbable material, and a shape  
20 memory alloy.

15. A system for closing an opening in tissue, comprising:  
a closure element having a coiled body and a plurality of tissue engaging portions disposed about at least a portion of said body, said body being formed of  
25 a resilient material; and  
a clip applier apparatus being configured to deploy said closure element into the tissue.

16. The system of claim 15, wherein the clip applier apparatus includes a  
30 locator assembly having a distal end region configured to extend into the opening and selectably contact a wall of the tissue and a proximal end configured to cooperate with a movable plunger, a carrier assembly coupled with said locating assembly, said carrier assembly retaining said closure element within said carrier assembly, and a triggering system cooperating with said locator assembly, said triggering system moveable toward

said distal end region of said locator assembly as said movable plunger moves toward said distal end region.

17. The system of claim 16, further comprising a housing receiving said  
5 locator assembly, said carrier assembly, and said triggering system.

18. The system of claim 16, wherein said locator assembly is configured to  
selectively control said distal end region of said locator assembly between an expanded  
state and an unexpanded state.

10

19. The system of claim 18, wherein said locator assembly further comprises a  
control member coupled to at least one expansion member and a tubular member  
configured to surround said control member.

20. The system of claim 19, wherein said locator assembly further comprises a  
15 tubular body block mounted to said tubular member, a spring retainer receiving a portion  
of said tubular body block, and said movable plunger slidably cooperating with said  
tubular body block and said tubular member.

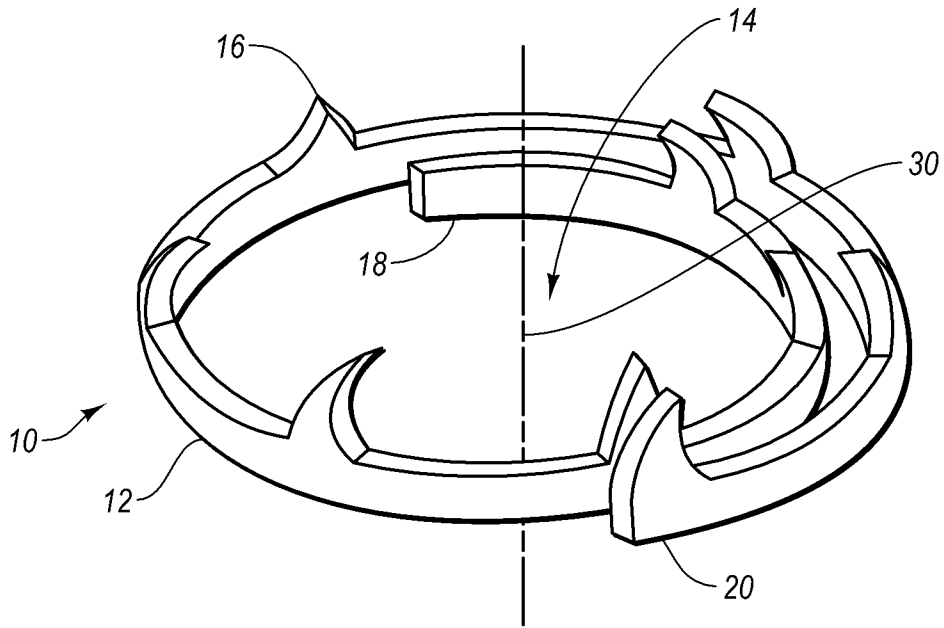

Fig. 1A

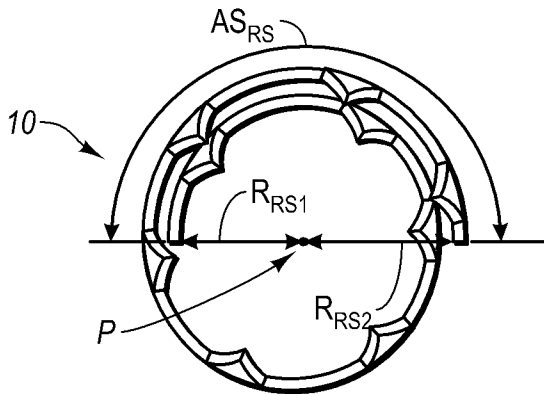

Fig. 1B

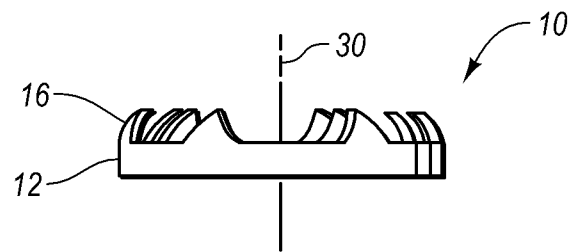

Fig. 1D

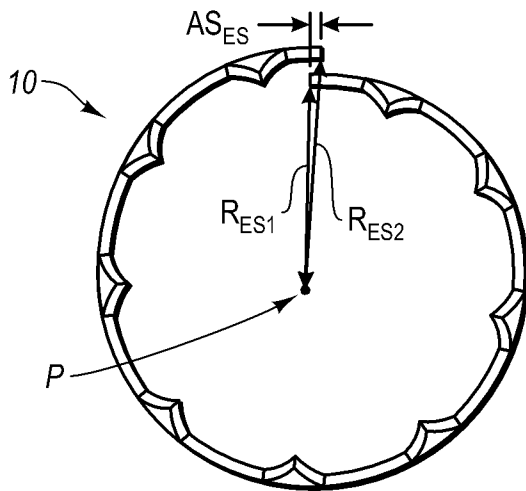
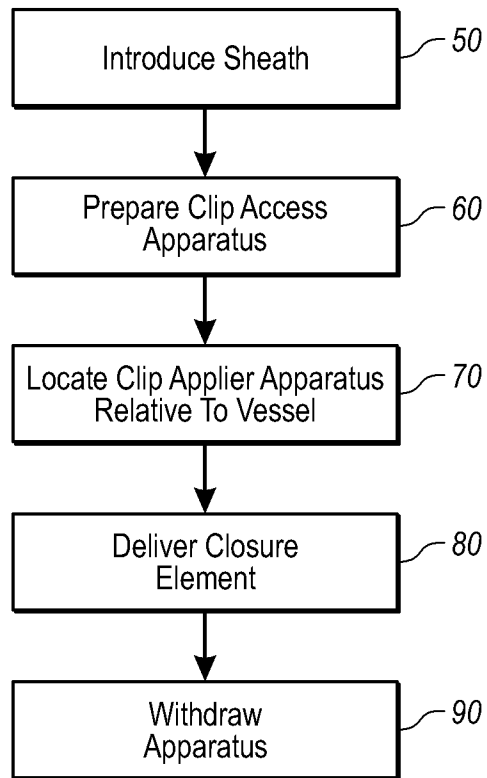

Fig. 1C



2 / 18



**Fig. 2**

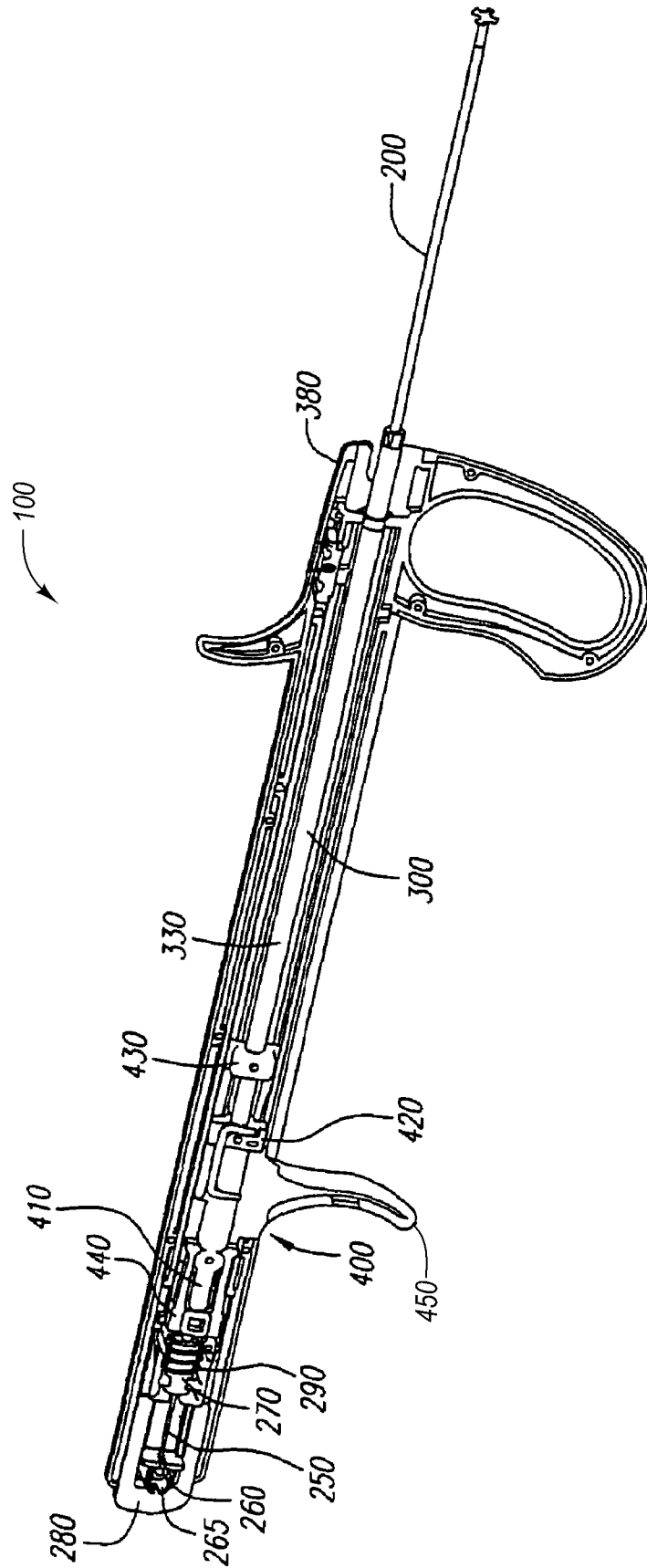
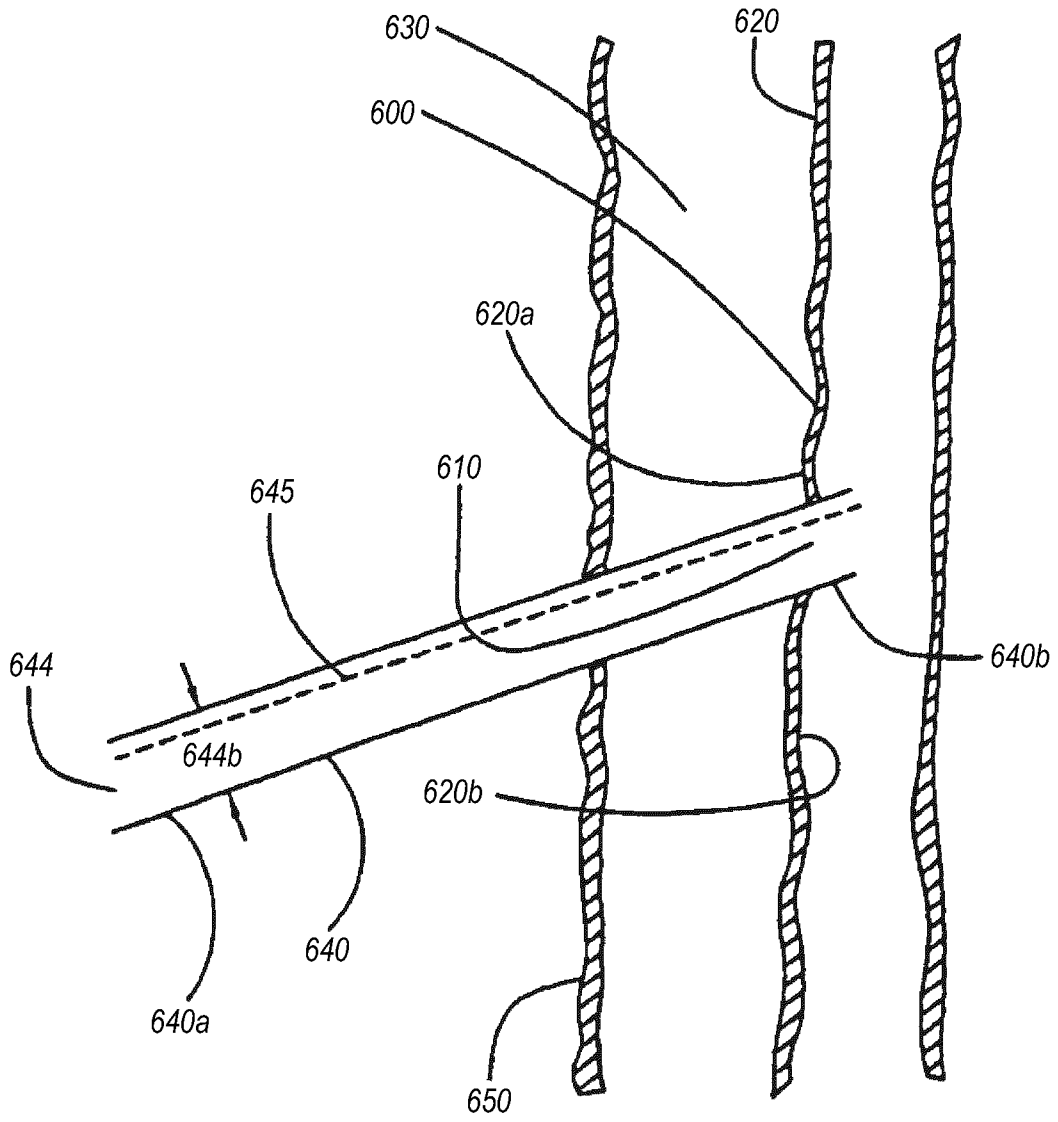

Fig. 3



**Fig. 4A**

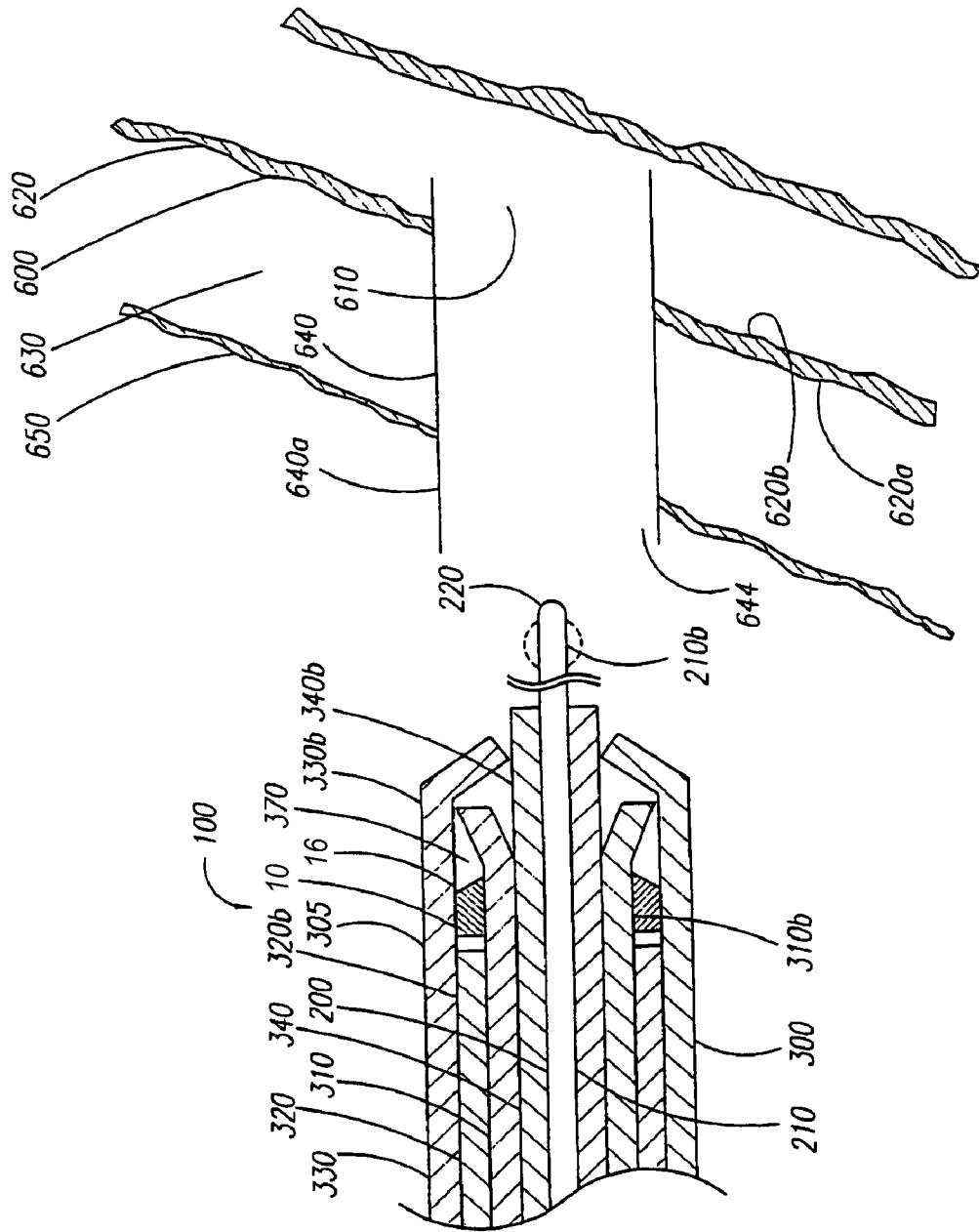

Fig. 4B

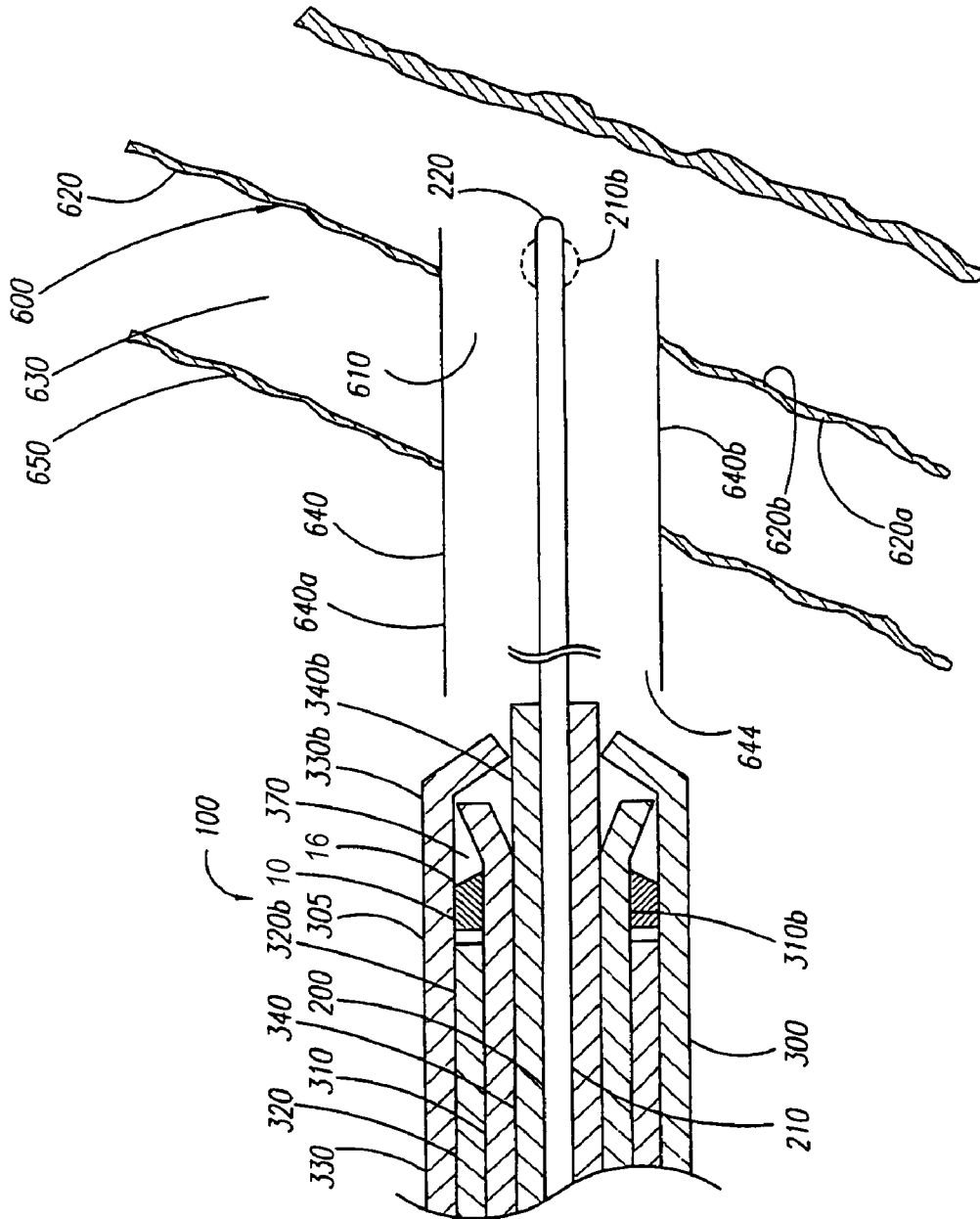

Fig. 4C

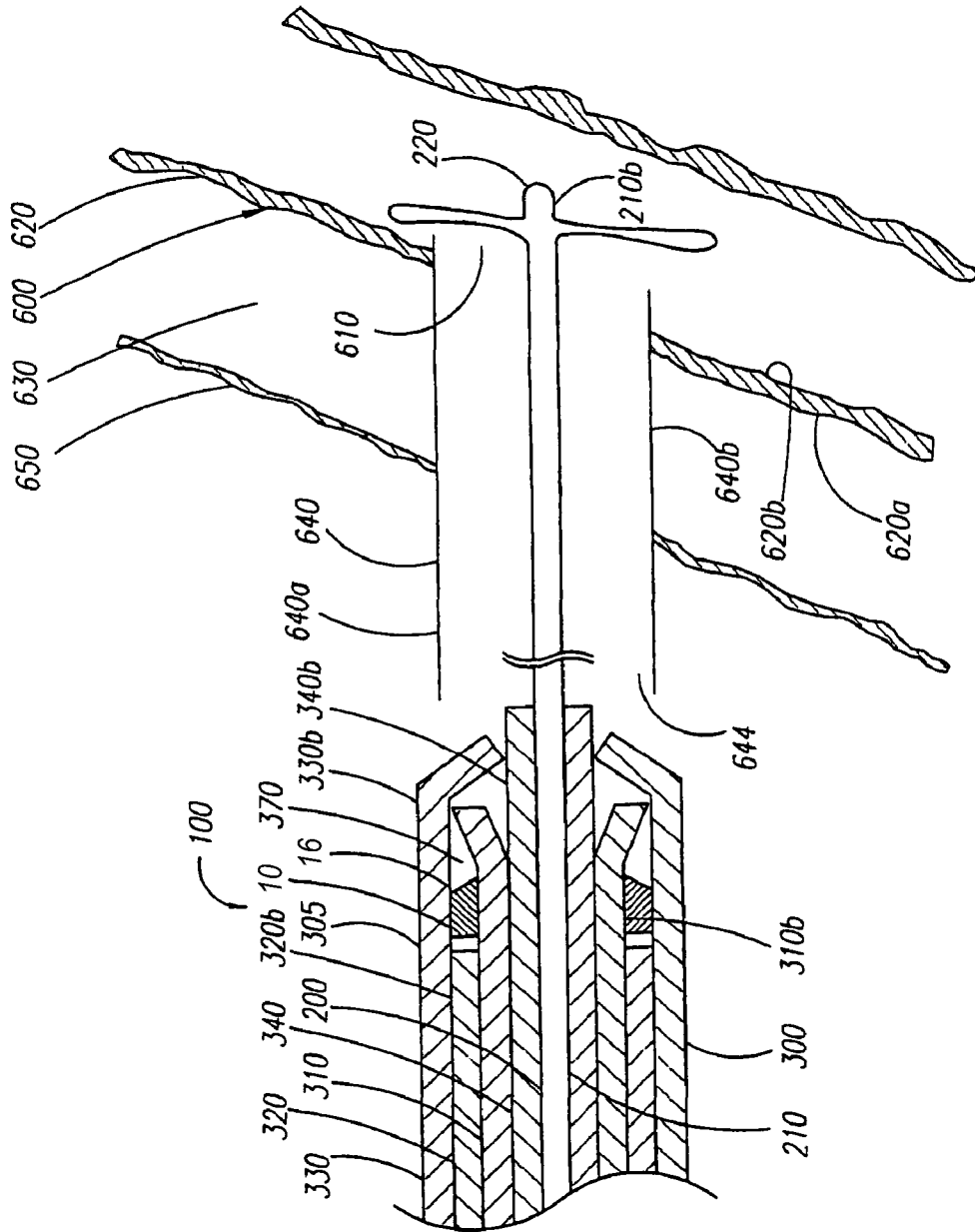

Fig. 4D

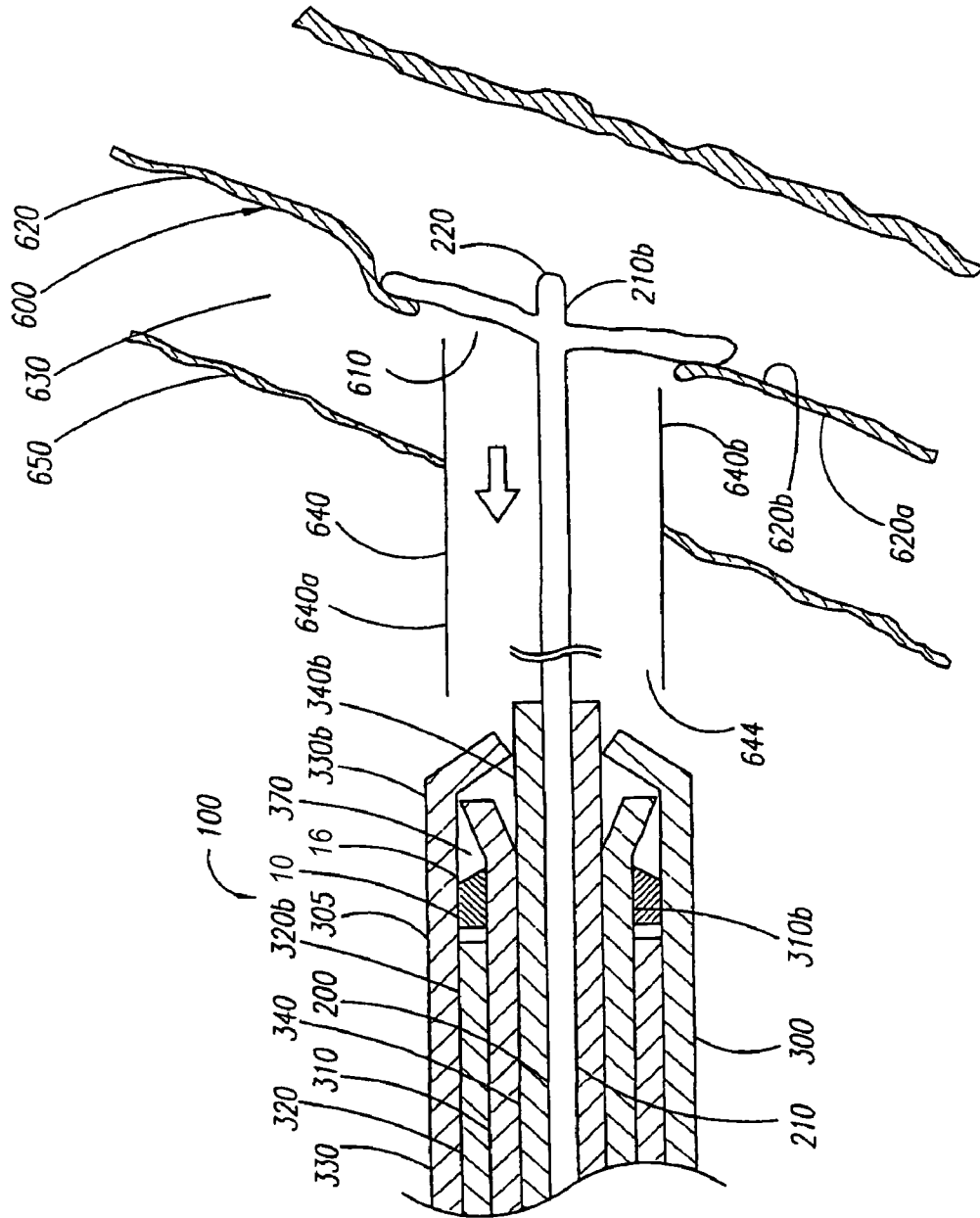

Fig. 4E

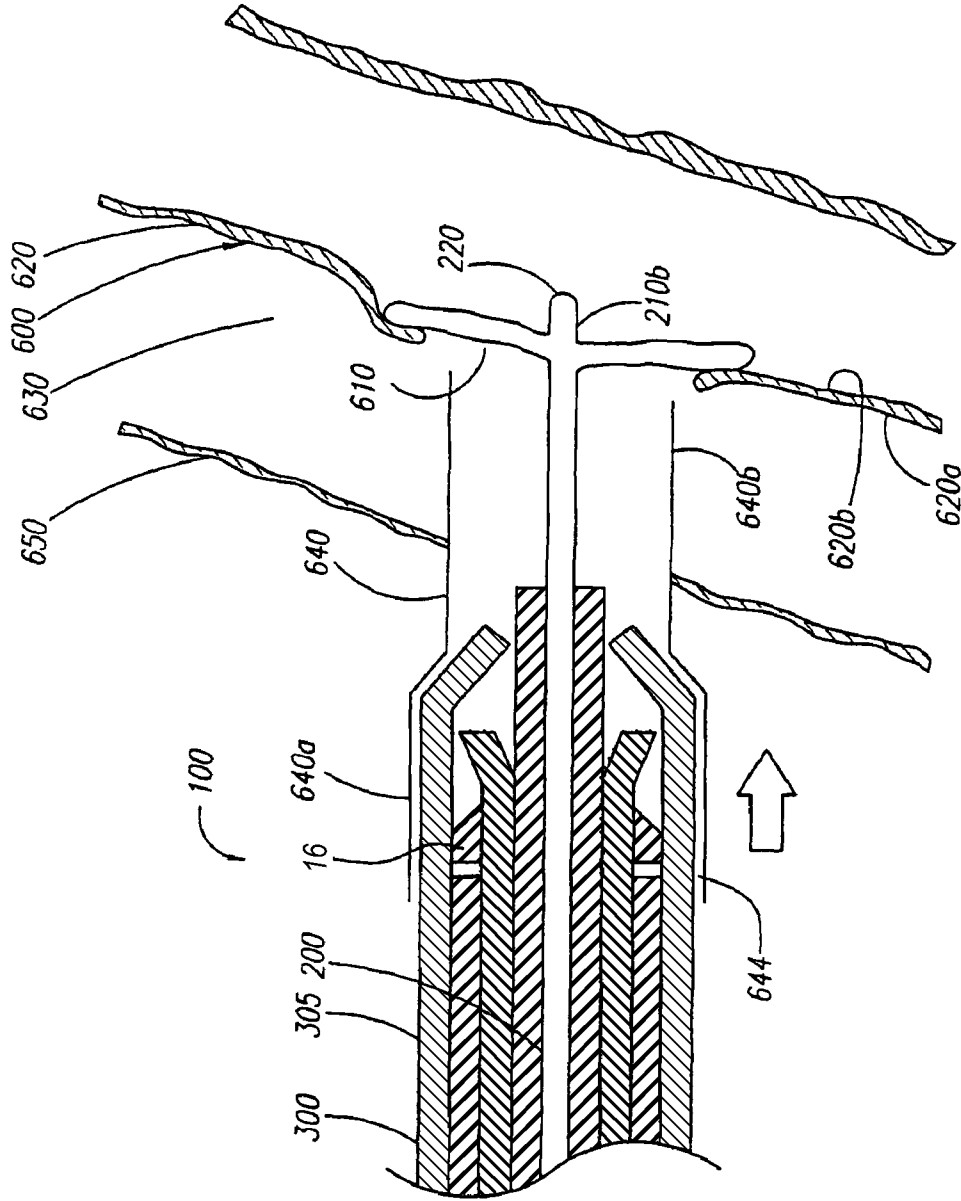

Fig. 4F



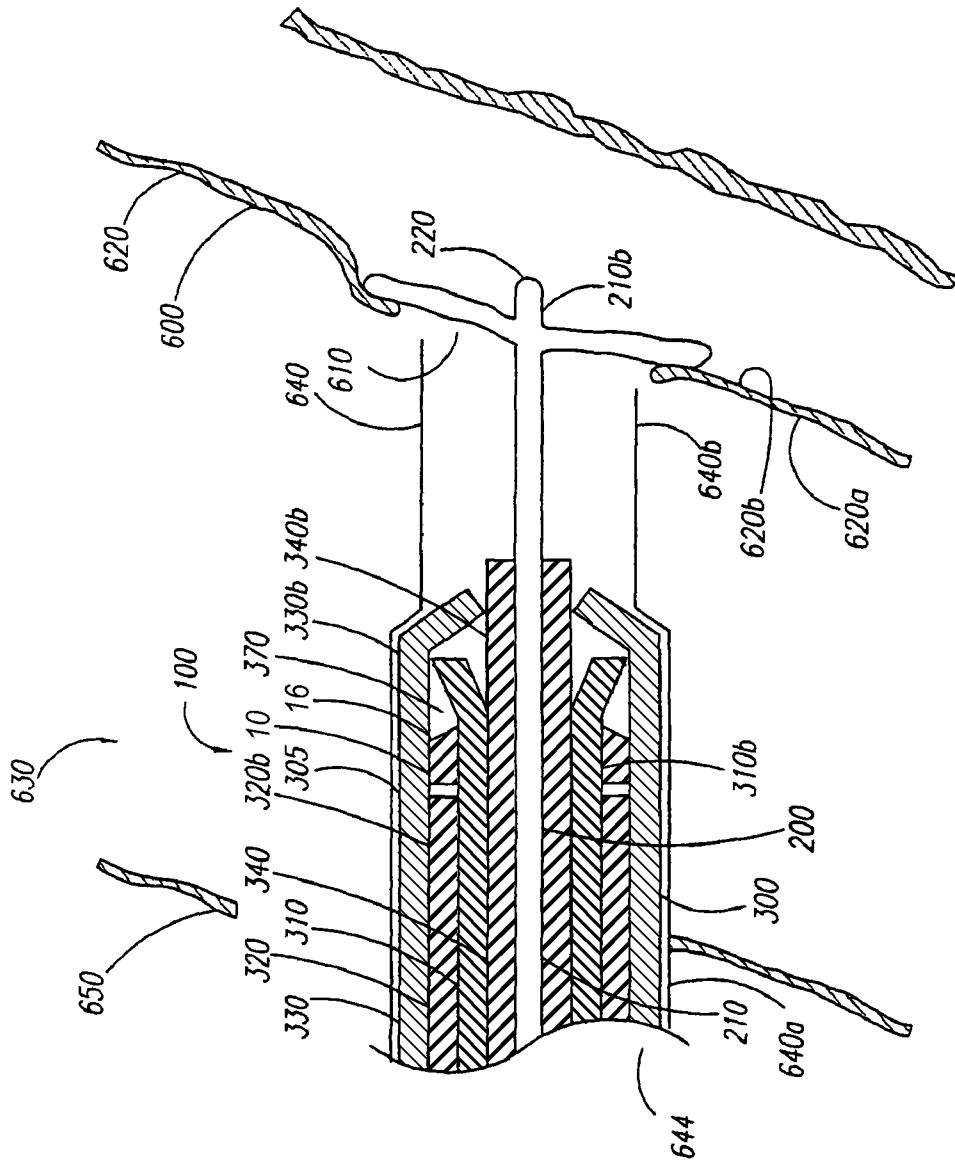

Fig. 4G

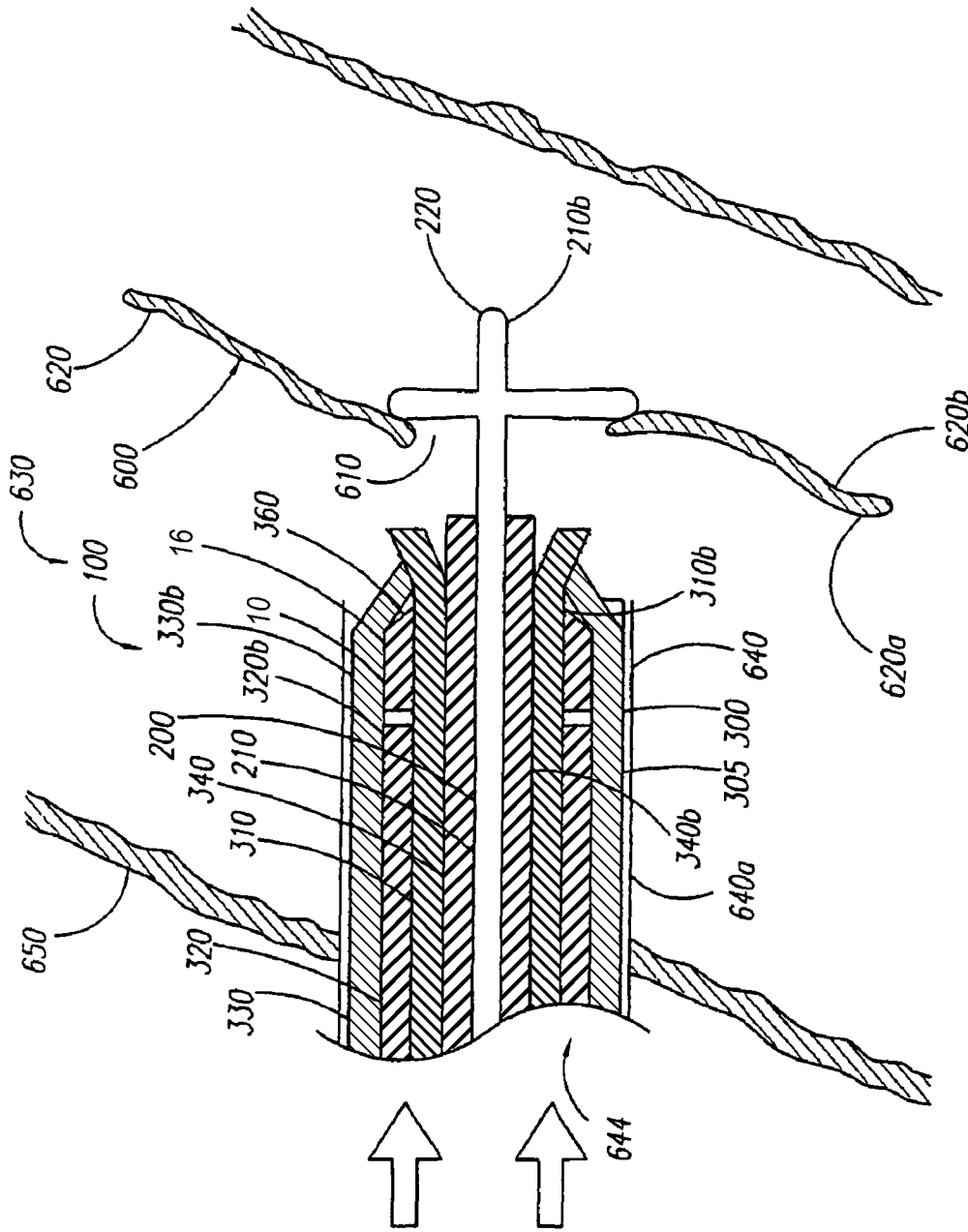

Fig. 4H

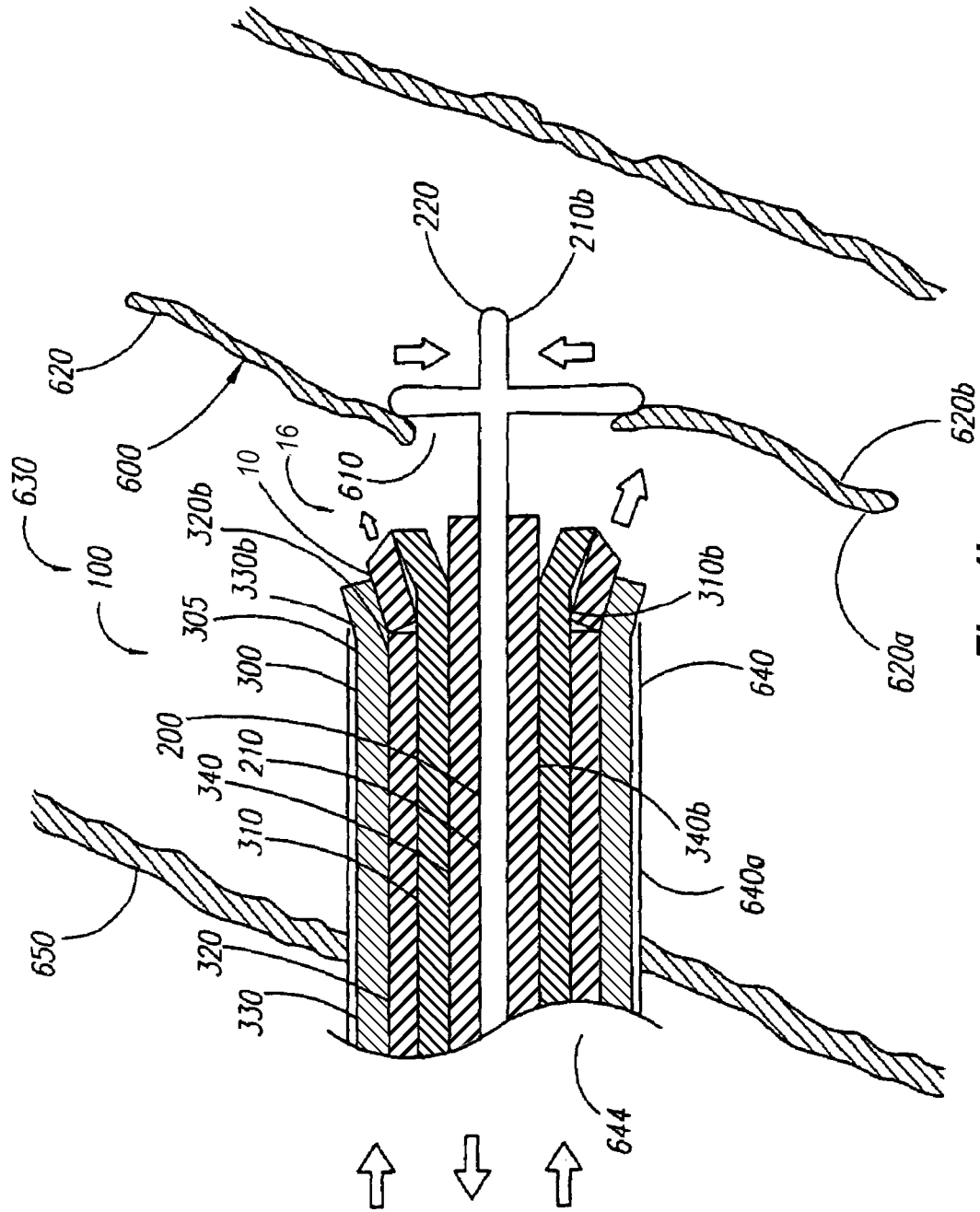

Fig. 4I

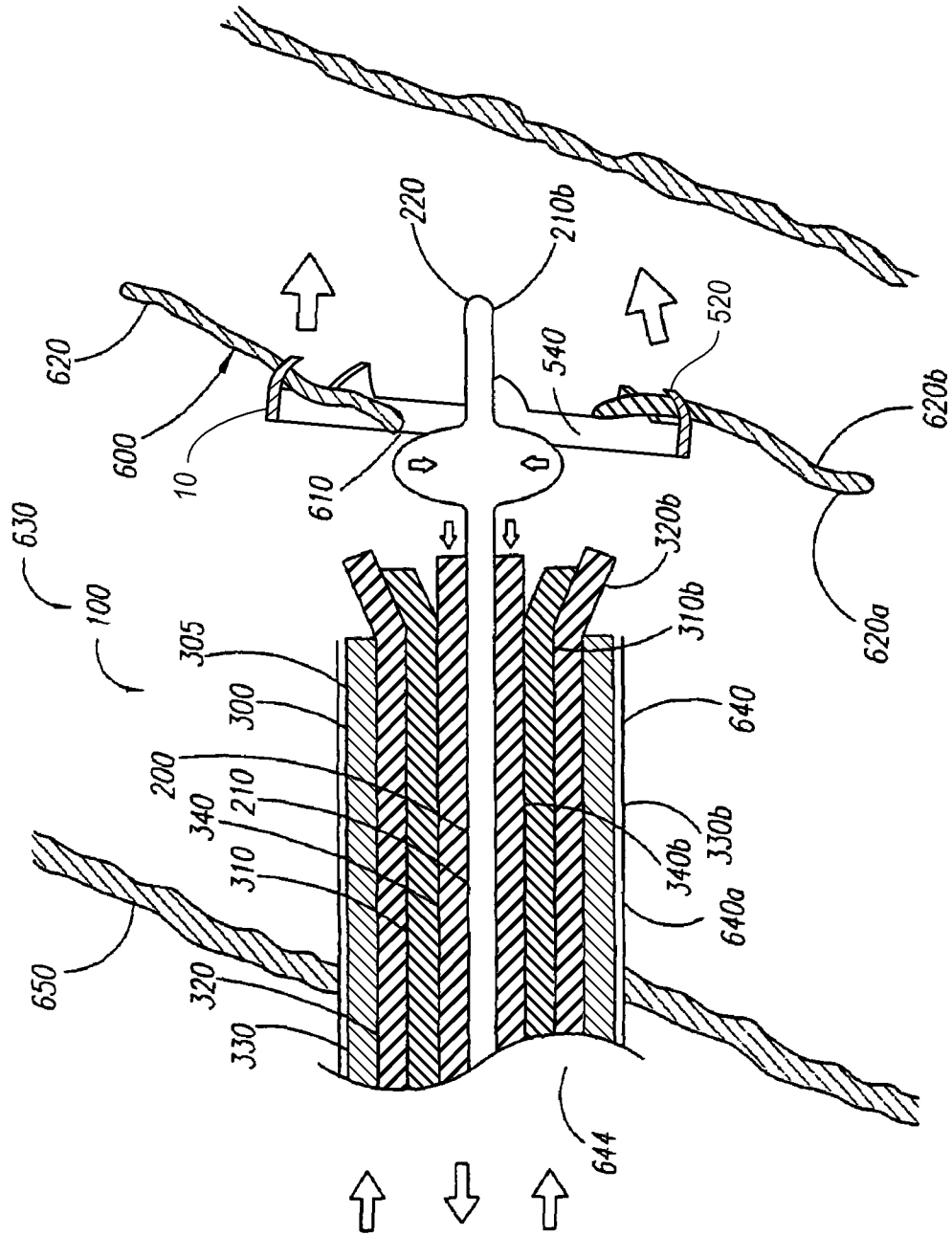

Fig. 4J

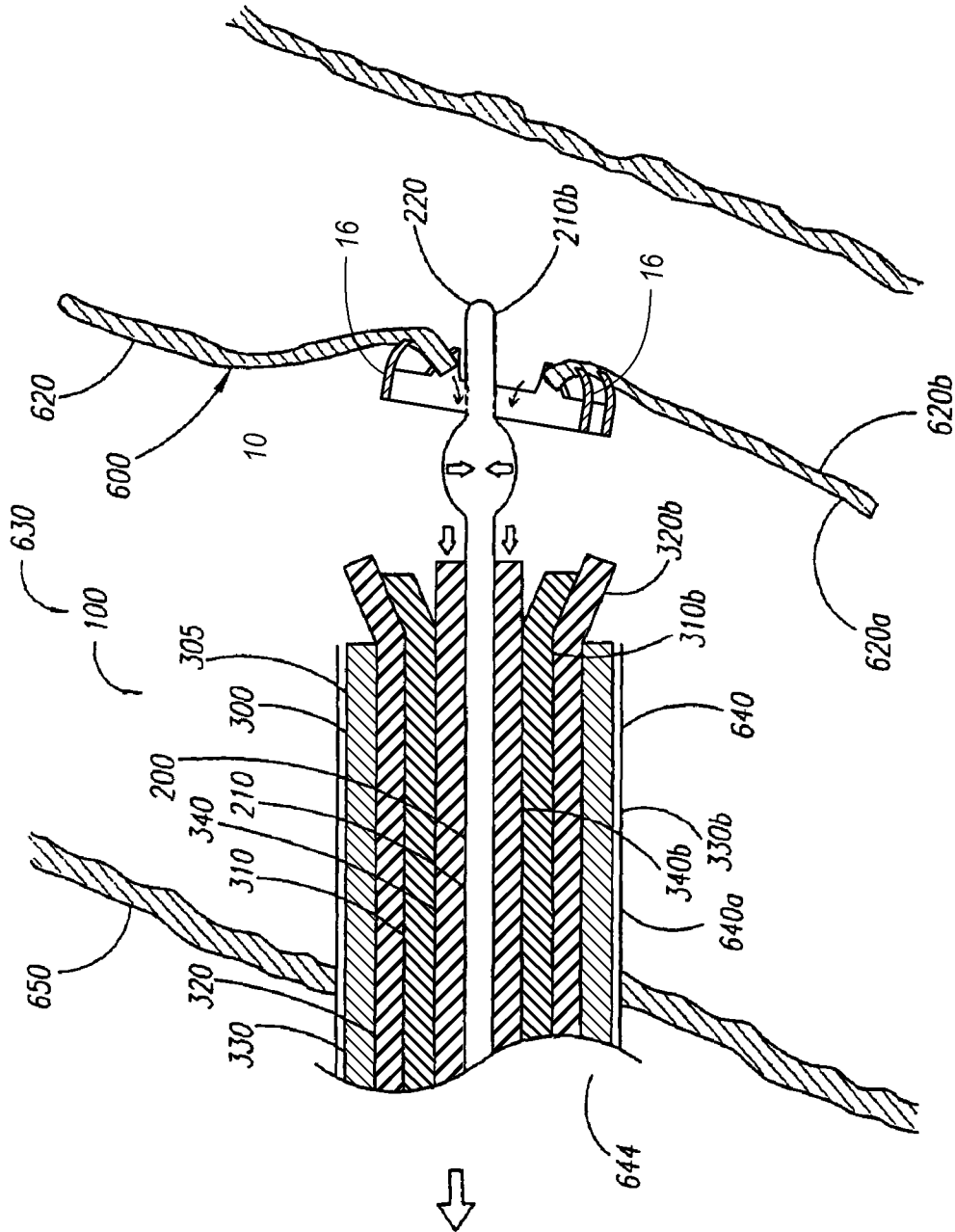

Fig. 4K

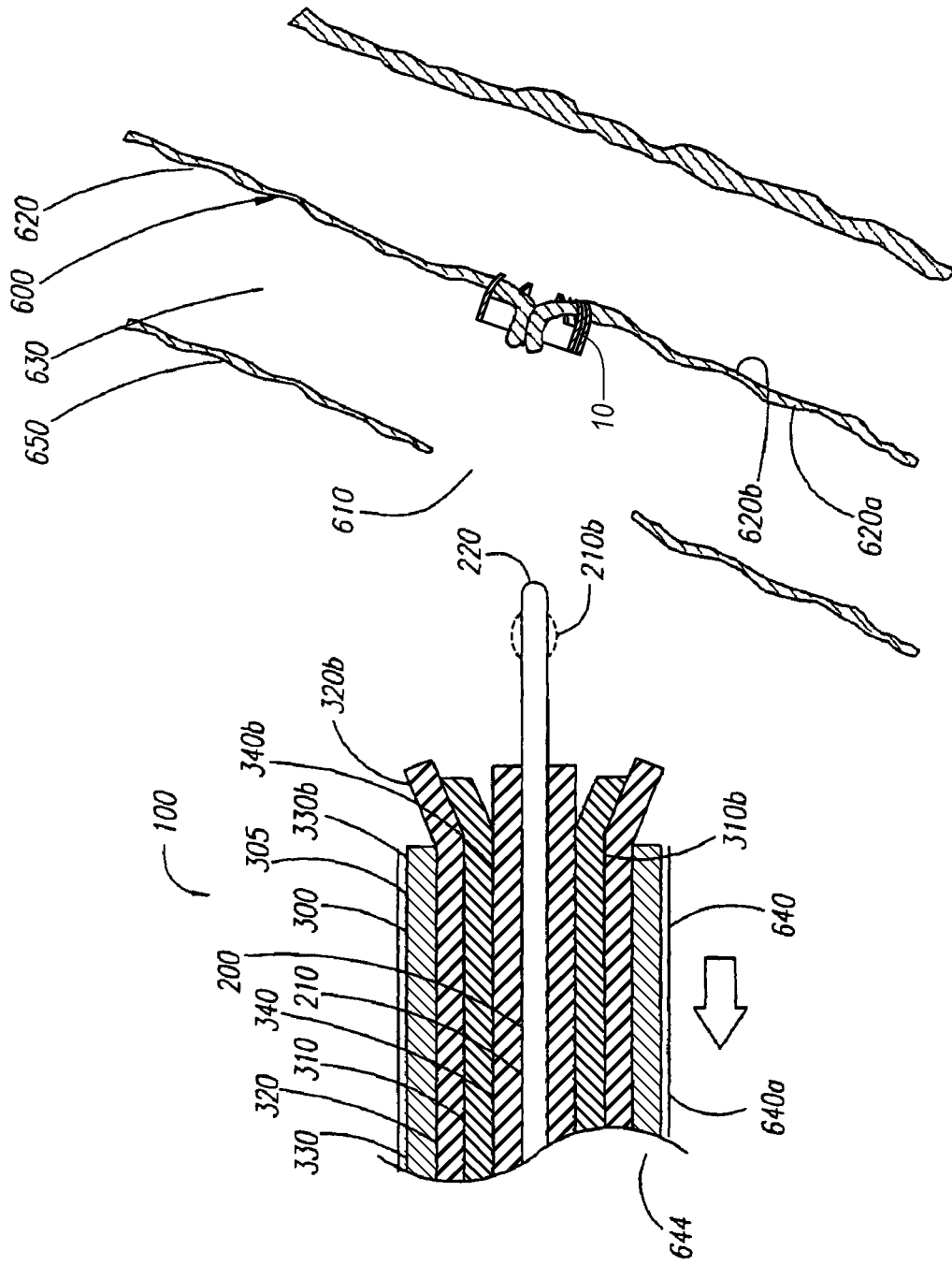

Fig. 4L

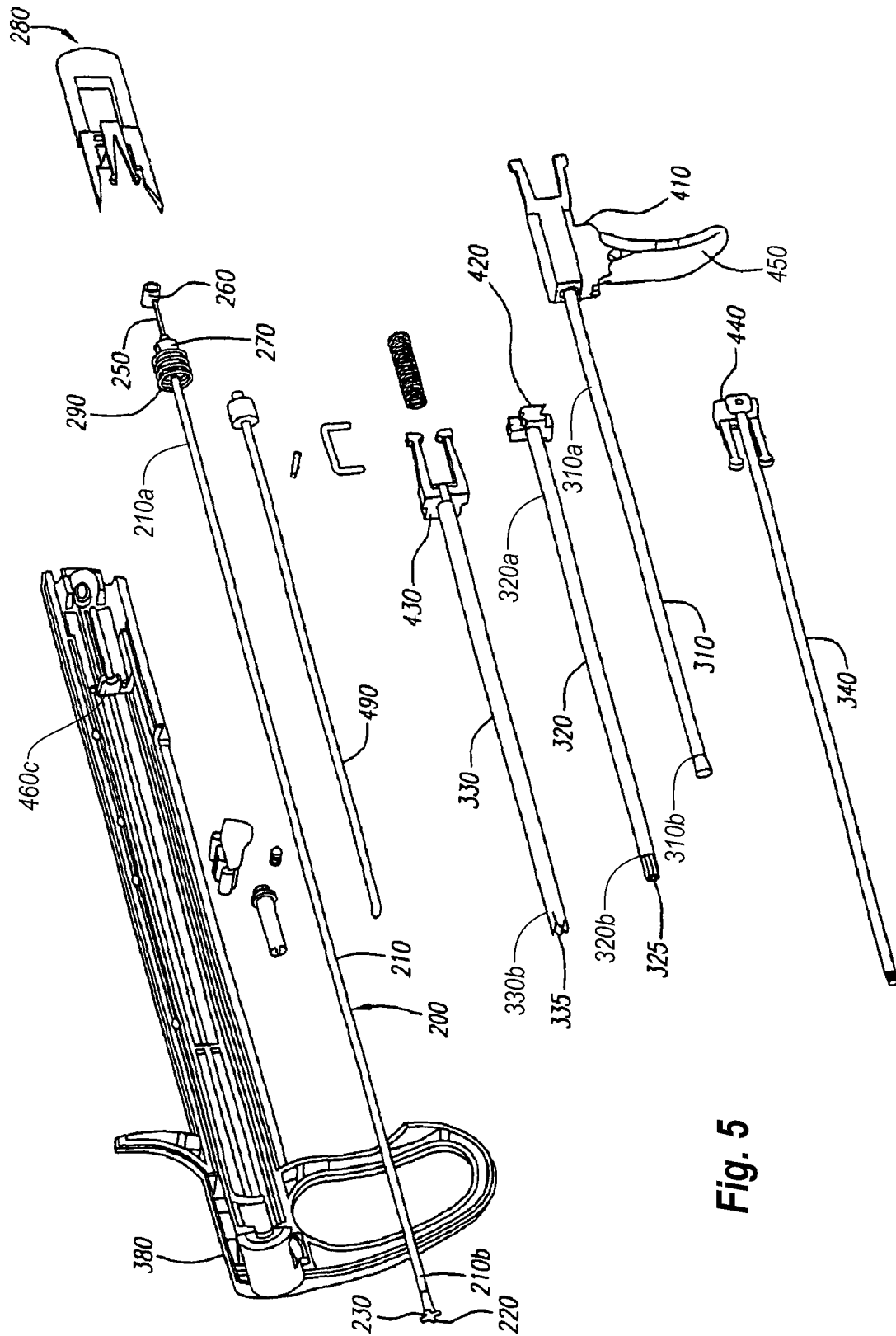

Fig. 5

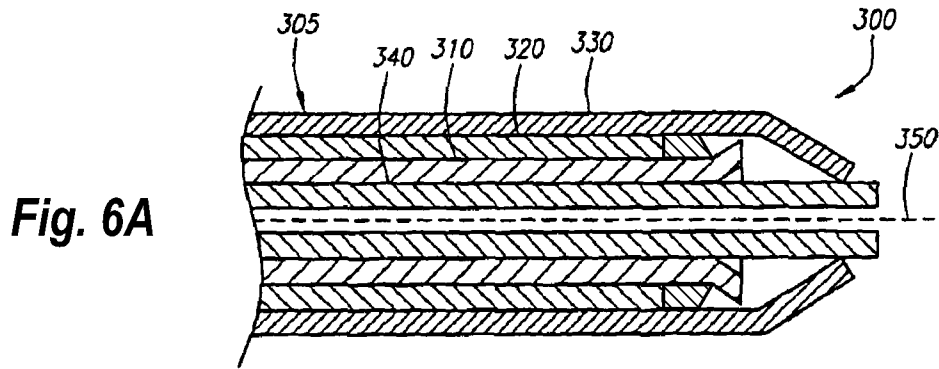

Fig. 6A

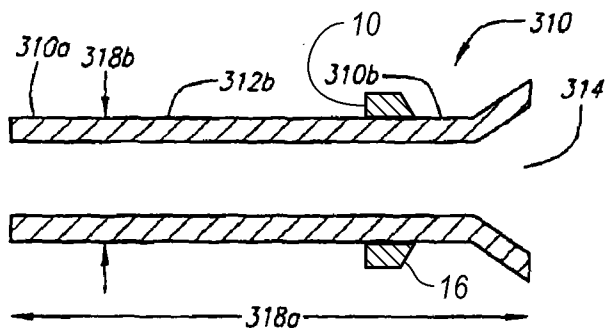

Fig. 6B

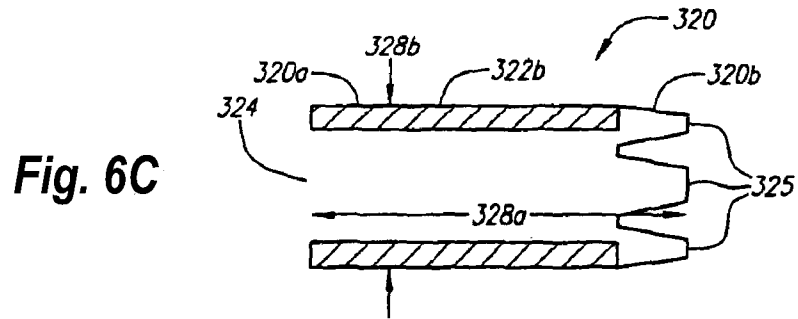

Fig. 6C

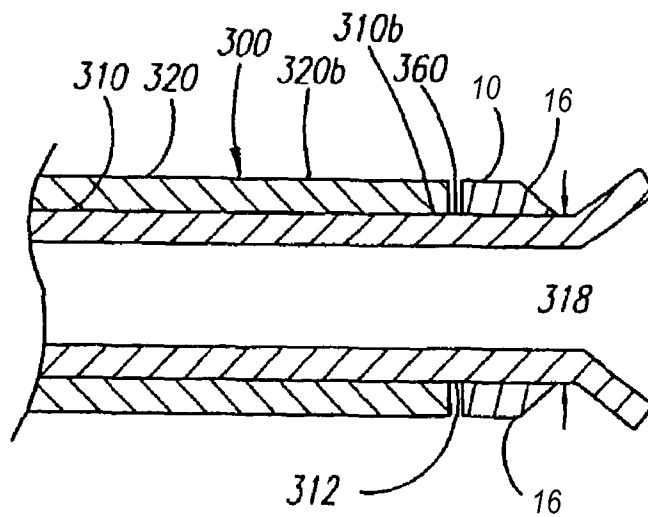
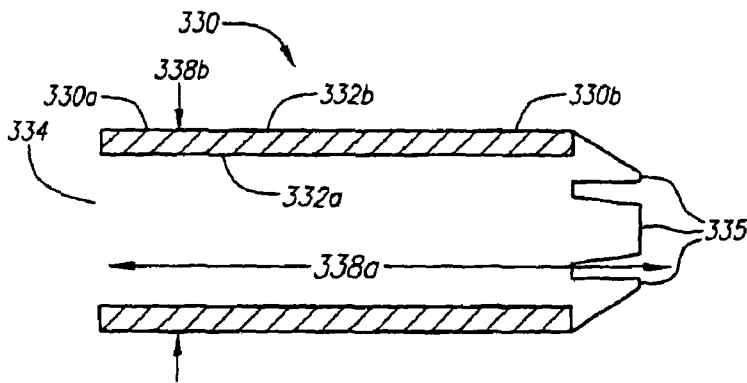
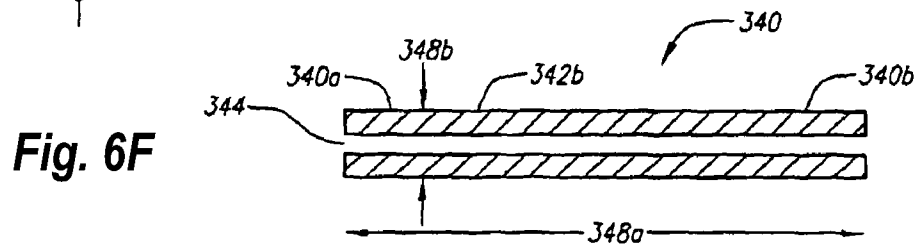

Fig. 6D





**Fig. 6E**



**Fig. 6F**

**INTERNATIONAL SEARCH REPORT**

International application No  
PCT/US2008/080643

**A. CLASSIFICATION OF SUBJECT MATTER**  
INV. A61B17/00      A61B17/064      A61B17/068      A61B17/08

According to International Patent Classification (IPC) or to both national classification and IPC

**B. FIELDS SEARCHED**

Minimum documentation searched (classification system followed by classification symbols)  
A61B

Documentation searched other than minimum documentation to the extent that such documents are included in the fields searched

Electronic data base consulted during the international search (name of data base and, where practical, search terms used)

EPO-Internal

**C. DOCUMENTS CONSIDERED TO BE RELEVANT**

Category*	Citation of document, with indication, where appropriate, of the relevant passages	Relevant to claim No.
X	US 7 060 084 B1 (LOSHAKOVE ET AL.) 13 June 2006 (2006-06-13) abstract; figures 2A,2B column 10, lines 18-29 column 10, line 62 - column 11, line 14	1-14
Y	-----	15-20
Y	WO 2007/005585 A (ABBOTT LABORATORIES) 11 January 2007 (2007-01-11) the whole document	15-20
A	US 2005/234508 A1 (CUMMINS ET AL.) 20 October 2005 (2005-10-20) abstract; figures paragraph [0035]	1,7
	----- -/--	

Further documents are listed in the continuation of Box C.

See patent family annex.

\* Special categories of cited documents :

- \*A\* document defining the general state of the art which is not considered to be of particular relevance
- \*E\* earlier document but published on or after the international filing date
- \*L\* document which may throw doubts on priority claim(s) or which is cited to establish the publication date of another citation or other special reason (as specified)
- \*O\* document referring to an oral disclosure, use, exhibition or other means
- \*P\* document published prior to the international filing date but later than the priority date claimed

- \*T\* later document published after the international filing date or priority date and not in conflict with the application but cited to understand the principle or theory underlying the invention
- \*X\* document of particular relevance; the claimed invention cannot be considered novel or cannot be considered to involve an inventive step when the document is taken alone
- \*Y\* document of particular relevance; the claimed invention cannot be considered to involve an inventive step when the document is combined with one or more other such documents, such combination being obvious to a person skilled in the art.
- \* & \* document member of the same patent family

Date of the actual completion of the international search

3 December 2008

Date of mailing of the international search report

12/12/2008

Name and mailing address of the ISA/

European Patent Office, P.B. 5818 Patentlaan 2  
NL - 2280 HV Rijswijk  
Tel. (+31-70) 340-2040,  
Fax: (+31-70) 340-3016

Authorized officer

Giménez Burgos, R

INTERNATIONAL SEARCH REPORT

International application No  
PCT/US2008/080643

C(Continuation). DOCUMENTS CONSIDERED TO BE RELEVANT		
Category*	Citation of document, with indication, where appropriate, of the relevant passages	Relevant to claim No.
A	WO 2006/000514 A (CARDIO LIFE RESEARCH S.A.) 5 January 2006 (2006-01-05) abstract; figures -----	1,7
A	US 3 586 002 A (WOOD) 22 June 1971 (1971-06-22) the whole document -----	1,7

# INTERNATIONAL SEARCH REPORT

Information on patent family members

International application No <b>PCT/US2008/080643</b>
----------------------------------------------------------

Patent document cited in search report	Publication date	Patent family member(s)	Publication date
US 7060084	B1	13-06-2006 NONE	
WO 2007005585	A	11-01-2007 EP 1909651 A2	16-04-2008
US 2005234508	A1	20-10-2005 NONE	
WO 2006000514	A	05-01-2006 CA 2570738 A1 JP 2008504053 T	05-01-2006 14-02-2008
US 3586002	A	22-06-1971 NONE	