

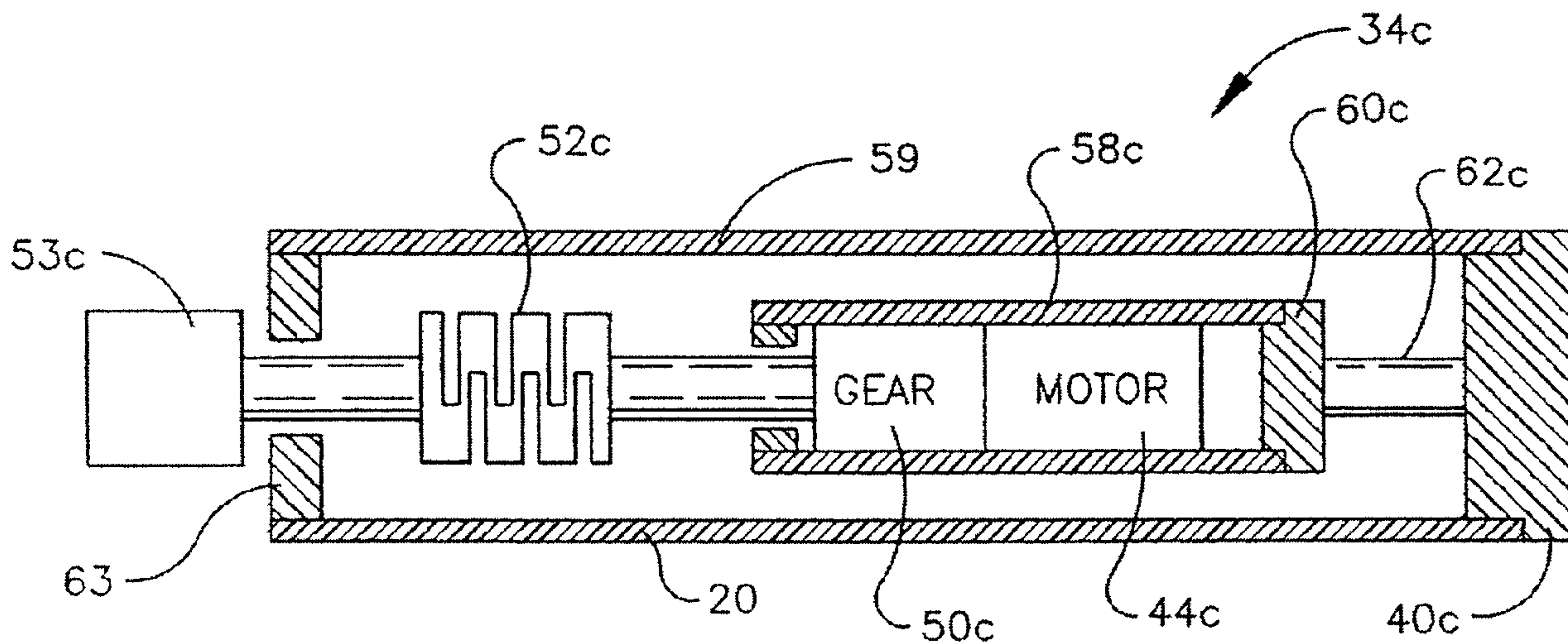

(86) Date de dépôt PCT/PCT Filing Date: 2005/03/15
 (87) Date publication PCT/PCT Publication Date: 2005/09/29
 (45) Date de délivrance/Issue Date: 2013/01/29
 (85) Entrée phase nationale/National Entry: 2006/08/24
 (86) N° demande PCT/PCT Application No.: IB 2005/000655
 (87) N° publication PCT/PCT Publication No.: 2005/090736
 (30) Priorité/Priority: 2004/03/16 (US10/801,303)

(51) Cl.Int./Int.Cl. *E06B 9/68* (2006.01),
E06B 9/174 (2006.01)
 (72) Inventeurs/Inventors:
CAVAREC, PIERRE-EMMANUEL, US;
HAUCK, ERIC W., US;
MORRISON, TIMOTHY, US
 (73) Propriétaire/Owner:
SOMFY SAS, FR
 (74) Agent: FETHERSTONHAUGH & CO.

(54) Titre : DISPOSITIF ELECTRIQUE POUR RECOUVREMENT DE FENETRE AMOVIBLE
 (54) Title: ELECTRICAL POWER-DRIVE DEVICE FOR A MOVABLE WINDOW COVERING



(57) **Abrégé/Abstract:**

The electrical power-drive device (34c) for movable window covering and/or screen, awning, roller-door, roller-shutter, comprises a mechanical subset including at least one motor (44c), a first output shaft (53c) and at least one stationary mount (40c). The subset is elastically coupled by at least a first main rotatable elastic coupling means (52c) to the first output shaft and by a second main non-rotatable elastic coupling means (62c) to a non-rotatable tube (59) enclosing the subset, the tube being connected to the stationary mount and guiding the first output shaft.

(12) INTERNATIONAL APPLICATION PUBLISHED UNDER THE PATENT COOPERATION TREATY (PCT)

(19) World Intellectual Property
Organization
International Bureau



(43) International Publication Date
29 September 2005 (29.09.2005)

PCT

(10) International Publication Number
WO 2005/090736 A1

- (51) International Patent Classification⁷: **E06B 9/68**, 9/174
- (21) International Application Number:
PCT/IB2005/000655
- (22) International Filing Date: 15 March 2005 (15.03.2005)
- (25) Filing Language: English
- (26) Publication Language: English
- (30) Priority Data:
10/801,303 16 March 2004 (16.03.2004) US
- (71) Applicant (for all designated States except US): **SOMFY SAS** [FR/FR]; 50, Avenue du Nouveau Monde, F-74300 CLUSES (FR).
- (72) Inventors; and
- (75) Inventors/Applicants (for US only): **CAVAREC, Pierre-Emmanuel** [FR/US]; 10808 Scripps Ranch Blvd. #105, San Diego, CA 92131 (US). **HAUCK, Eric W.** [US/US]; La Alberca Avenue, SAN DIEGO, CA 92127 (US). **MORRISON, Timothy** [US/US]; 1586 Mission Meadows, OCEANSIDE, CA 92057 (US).
- (74) Agents: **GROSFILLIER, Philippe** et al.; C/O BUGNION S.A., Case Postale 375, CH-1211 Genève 12 (CH).
- (81) Designated States (unless otherwise indicated, for every kind of national protection available): AE, AG, AL, AM, AT, AU, AZ, BA, BB, BG, BR, BW, BY, BZ, CA, CH, CN, CO, CR, CU, CZ, DE, DK, DM, DZ, EC, EE, EG, ES, FI, GB, GD, GE, GH, GM, HR, HU, ID, IL, IN, IS, JP, KE, KG, KP, KR, KZ, LC, LK, LR, LS, LT, LU, LV, MA, MD, MG, MK, MN, MW, MX, MZ, NA, NI, NO, NZ, OM, PG, PH, PL, PT, RO, RU, SC, SD, SE, SG, SK, SL, SM, SY, TJ, TM, TN, TR, TT, TZ, UA, UG, US, UZ, VC, VN, YU, ZA, ZM, ZW.
- (84) Designated States (unless otherwise indicated, for every kind of regional protection available): ARIPO (BW, GH, GM, KE, LS, MW, MZ, NA, SD, SL, SZ, TZ, UG, ZM, ZW), Eurasian (AM, AZ, BY, KG, KZ, MD, RU, TJ, TM), European (AT, BE, BG, CH, CY, CZ, DE, DK, EE, ES, FI, FR, GB, GR, HU, IE, IS, IT, LT, LU, MC, NL, PL, PT, RO, SE, SI, SK, TR), OAPI (BF, BJ, CF, CG, CI, CM, GA, GN, GQ, GW, ML, MR, NE, SN, TD, TG).
- Published:**
— with international search report
- For two-letter codes and other abbreviations, refer to the "Guidance Notes on Codes and Abbreviations" appearing at the beginning of each regular issue of the PCT Gazette.

(54) Title: ELECTRICAL POWER-DRIVE DEVICE FOR A MOVABLE WINDOW COVERING

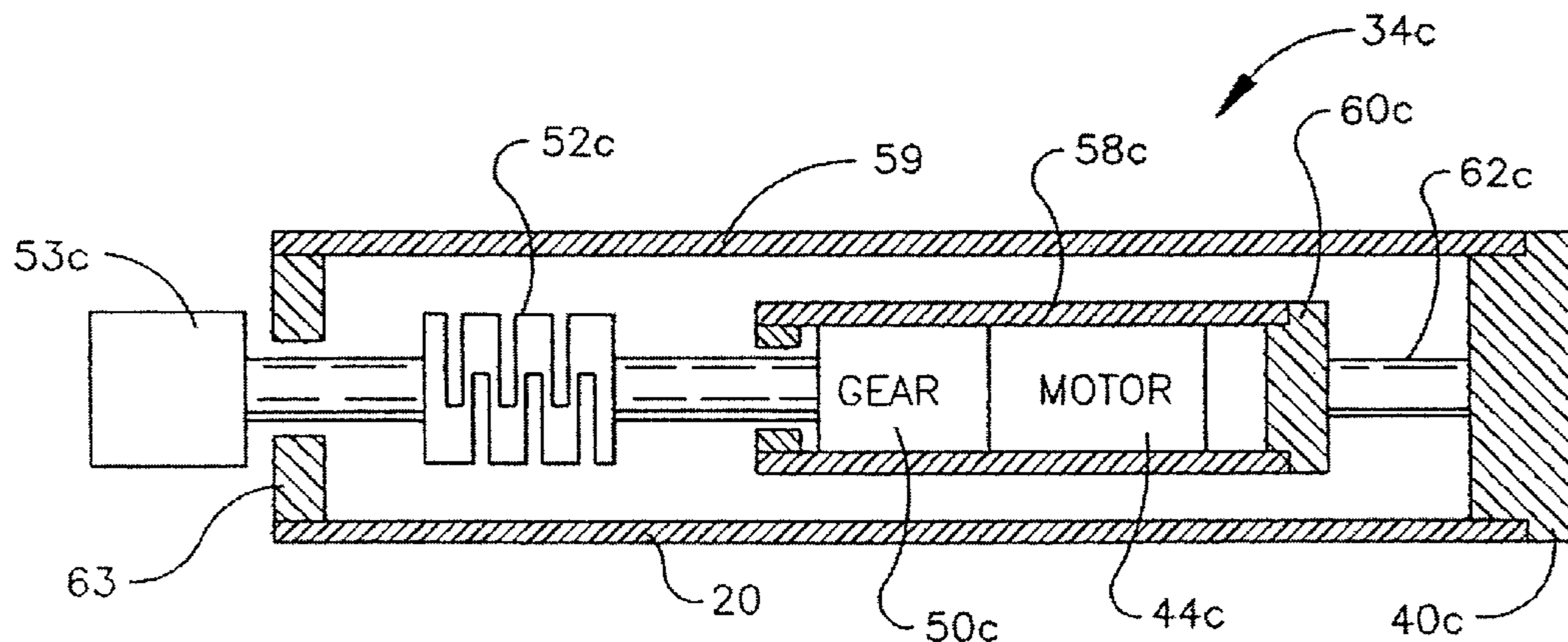

(57) Abstract: The electrical power-drive device (34c) for movable window covering and/or screen, awning, roller-door, roller-shutter, comprises a mechanical subset including at least one motor (44c), a first output shaft (53c) and at least one stationary mount (40c). The subset is elastically coupled by at least a first main rotatable elastic coupling means (52c) to the first output shaft and by a second main non-rotatable elastic coupling means (62c) to a non-rotatable tube (59) enclosing the subset, the tube being connected to the stationary mount and guiding the first output shaft.

WO 2005/090736 A1

- 1 -

Electrical power-drive device for a movable window covering**1. Field of the Invention**

The present invention relates generally to motorized window coverings.

2. Background of the Invention

The present assignee has provided several systems for either lowering or raising a window covering, or for moving the slats of a window covering between open and closed positions, under control of a hand-held remote or other control device. These systems include a motor that is coupled through gears to the window covering activation mechanism. When the motor is energized in response to a user command signal, the activation mechanism moves the window covering.

As recognized herein, it is desirable to minimize the noise emitted by such systems during operations. As further recognized herein, most of the noise is due to vibrations of the head rail caused by vibrations of the motor within the head rail.

An electrical power-drive device is known from patent US 5,671,387. This device comprises a motor and gear train assembly connected to a rotatable winding tube and to a stationary mount via elastic coupling means. Such a device does not permit a good noise attenuation.

The aim of the invention is to provide a device for that allows the aforementioned drawbacks to be overcome and that provides an improvement with respect to the known devices of the state of the art. In particular, the invention allows to minimize the noise the device emits when the motor is energized. The invention also relates to a powered assembly including such a device.

- 2 -

SUMMARY OF THE INVENTION

In one aspect of the present invention, there is provided an electrical power-drive device for movable window covering and/or screen, awning, roller-door or roller-shutter. The power-drive device comprises a mechanical subset including at least one motor, a first output shaft and at least one stationary mount. The subset is elastically coupled by at least a first main rotatable elastic coupling means to the first output shaft and by a second main non-rotatable elastic coupling means to a non-rotatable tube enclosing the subset. The tube is connected to the stationary mount and guides the first output shaft.

A powered assembly includes an object such as a window covering that can be moved between an open configuration and a closed configuration, and a preferably battery-powered motor that is coupled, through a gear train, to an actuator to move the object when the motor is energized. The motor may be powered from the AC electrical grid for applications requiring more power. At least one noise dampening coupling is either interposed between the gear train and the actuator to couple rotational motion of the gear train to the actuator, or is disposed between the motor and a stationary head rail mount to couple the motor to the mount.

The noise dampening coupling can be a metal or plastic cylinder that has slots formed in it such that it is flexible about its longitudinal axis but is substantially resistant to twisting under the influence of torque about its longitudinal axis.

The noise dampening coupling can be a rotatable noise dampening coupling that couples the gear train to an actuator adaptor, and the assembly can also include at least one non-rotatable noise dampening coupling that couples the motor to a head rail mount. The non-rotatable noise dampening coupling may surround the rotatable noise dampening coupling, or the motor may be interposed between the non-rotatable noise dampening coupling and the rotatable noise dampening coupling. Furthermore, a secondary rotatable noise dampening coupling can be interposed between the rotatable

- 3 -

noise dampening coupling and the actuator, with the rotatable noise dampening couplings rotating together.

In one preferred non-limiting embodiment, a metal tube can be positioned within the head rail and surround the motor and gear train but not the secondary rotatable noise dampening coupling. In this embodiment, a secondary non-rotatable noise dampening coupling can be interposed between the head rail mount and motor.

In another aspect, a drive assembly for a window covering that includes an actuator in a head rail includes an electrically-powered drive structure couplable to the actuator to move the window covering when the drive structure is energized. At least one noise dampening coupling is engaged with the drive structure and couplable either to the actuator to couple the drive structure to the actuator while suppressing transmission of vibrations from the drive structure to the head rail, and/or to a head rail mount to engage the drive structure with the head rail.

In still another aspect, a drive assembly for a window covering that includes an actuator in a head rail includes an electrically-powered drive structure couplable to the actuator to move the window covering when the drive structure is energized. Means couple the drive structure to the actuator and/or to the head rail while suppressing transmission of vibrations from the drive structure to the head rail.

The details of the present invention, both as to its construction and operation, can best be understood in reference to the accompanying drawings, in which like numerals refer to like parts, and which:

BRIEF DESCRIPTION OF THE DRAWINGS

Figure 1 is a perspective view of a window covering actuator, shown in one intended environment, with portions of the head rail cut away;

- 4 -

Figure 2 is a side view of a first embodiment of the internally suspended motor, with portions of the stationary tube that establishes one version of the non-rotatable noise dampening coupling cut away for clarity;

Figure 3 is an isometric view of one preferred non-limiting noise coupling;

Figure 4 is a side view of a second embodiment of the internally suspended motor sans the head rail, with the sides of the steel tube and the first non-rotatable noise dampening coupling removed for clarity;

Figure 5 is a side view of a third embodiment of the internally suspended motor, including a depiction of the head rail, with the sides of the steel tube and the head rail removed for clarity;

Figure 6 is a side view of a fourth embodiment of the internally suspended motor; and

Figure 7 is a side view of the system embodied in a screen.

DETAILED DESCRIPTION OF THE PREFERRED EMBODIMENT

Referring initially to Figure 1, a motorized window covering is shown, generally designated 10, that includes an actuator 12 such as a rotatable tilt rod or tube wheel of a window covering 14, such as but not limited to a shade assembly having raisable (by rolling up) and lowerable (by rolling down, or unrolling) shade 16. As shown, the actuator 12 is rotatably mounted by means of a block 18 in an upper hollow enclosure of the window covering 14, such as but not limited to head rail 20.

While a roll-up shade is shown, it is to be understood that the principles herein apply to a wide range of window coverings and other objects that are to be moved by motors.

- 5 -

For example, the invention applies to raisable and lowerable pleated shades and cellular shades as well as to projector screens, security screens, awnings, roller doors, etc. that can be raised and lowered from an upper enclosed hollow chamber. Moreover, the invention may also apply to tilting slat systems such as in horizontal blinds. Thus, for example, the rod 12 may be a roll-up rod of a shade, awning, or projector screen, or a tilt rod of a horizontal (or vertical) blind, or other like operator. It is thus to be further understood that the principles of the present invention apply to a wide range of window coverings and other objects including, but not limited to the following: vertical blinds, fold-up pleated shades, roll-up shades, cellular shades, skylight covers, etc. Powered versions of such shades are disclosed in U.S. Patent No. 6,433,498, incorporated herein by reference.

In the non-limiting illustrative embodiment shown, the window covering 14 is mounted on a window frame 22 to cover a window 24, and the rod 12 is rotatable about its longitudinal axis. The rod 12 can engage a user-manipulable baton (not shown). When the rod 12 is rotated about its longitudinal axis, the shade 16 raises or lowers between an open configuration and a closed configuration.

Figure 1 shows that the motorized window covering 10 can include a control signal receiver, preferably a signal sensor 26, for receiving a user command signal. Preferably, the user command signal is generated by a hand-held user command signal generator 28, which can be an infrared (IR) remote-control unit or a radio frequency (RF) remote-control unit. Or, the user command signal may be generated by any other means of communication well known in the art, such as by manipulable manual switches 29. The user command signals can include open, close, raise, lower, and so on.

An electronic circuit board 30 can be positioned in the head rail 20 and can be fastened to the head rail 20, e.g., by screws (not shown) or other well-known method. The

- 6 -

preferred electronic circuit board 30 includes a microprocessor for processing the control signals.

Figure 1 also shows that a noise-dampened motor and gear train assembly, generally designated 34, is provided in the head rail 20 for holding a preferably small, lightweight AC or DC electric motor that is coupled to a gear train as set forth more fully below. The noise-dampened motor and gear train assembly 34 is engaged with the actuator 12, so that when the below-described motor is energized, the actuator 12 rotates. The assembly 34 may be mounted on the circuit board 30 or other suitable location in the head rail. The assembly 34 may be thought of as establishing a mechanical subset.

It is to be understood that the below-described motor within the noise-dampened motor and gear train assembly 34 is electrically connected to the circuit board 30. To power the motor, one or more (four shown in Figure 1) primary dc batteries 36, such as type AA alkaline batteries or Lithium batteries, can be mounted in the head rail 20 and connected to the circuit board 30. Preferably, the batteries 36 are the sole source of power for the motor, although the present invention can also be applied to powered shades and other objects that are energized from the public ac power grid.

As set forth in the above-referenced U.S. Patent, a user can manipulate the signal generator 28 to generate a signal that is sensed by the signal sensor 26 and sent to signal processing circuitry in the circuit board 30. In turn, the electrical path between the batteries 34 and the motor is closed to energize the motor and move the window covering open or closed in accordance with the signal generated by the signal generator 28, under control of the processor on the electronic circuit board 30.

Now referring to a non-limiting illustrative embodiment in Figure 2, one preferred non-limiting embodiment of the assembly 34 can be seen. As shown, a hollow plastic or metal tube 38 is fixedly attached at an end thereof to a stanchion or mount 40, it being

- 7 -

understood that the mount 40 is affixed to the inside of the head rail 20 shown in Figure 1. The tube 38 is formed with plural slots 42 to establish a non-rotatable noise dampening coupling in accordance with principles further elucidated below.

As shown in Figure 2, a preferably twelve volt direct current motor 44 is held within the tube 38. It is to be understood that the motor 44 is electrically connected to the batteries 36 shown in Figure 1 by, e.g., electrical lines 46 or, for larger applications, to the electrical grid. A soft neoprene or other sound-dampening or shock-absorbing sound mount 48 is sandwiched between the motor 44 and tube 38 to hold the motor housing stationary within the tube. Also, a sound plug 49 may be tightly disposed in the tube 38 between the motor 44 and the end of the tube 38 that is affixed to the head rail 20 as shown.

Figure 2 also shows that a reduction gear train housing 50 is within the tube 38. The reduction gear train housing 50 holds reduction gears that are coupled to the motor 44 and that have an output gear (not shown) which owing to the gearing provided by the gear train, rotates at a slower speed than the rotor of the motor 44.

In accordance with the present invention, a rotatable noise dampening coupling 52 is affixed as by keying, gluing, or other method to the output gear of the gear train contained within the gear train housing 50. Consequently, the rotatable noise dampening coupling 52 rotates with the output gear. In the exemplary non-limiting embodiment shown, the rotatable noise dampening coupling 52 is a hollow cylindrical piece of plastic or metal that is formed with plural slots 54 to absorb vibration from the motor 44 in accordance with principles below.

Affixed to the rotatable noise dampening coupling 52 is an adaptor 56 that is configured for engaging the actuator 12 shown in Figure 1, so that rotational motion of the rotor of the motor 44 is reduced by the gear train and transferred through the rotatable noise

- 8 -

dampening coupling 52 and adaptor 56 to the actuator 12. The adaptor 56 may receive the actuator 12 therein as shown in Figure 1, in which case the interior channel of the adaptor 56 is shaped complementarily to the contour of the actuator 12, or the adaptor 56 may be received within the actuator 12 when the actuator 12 is, e.g., a rotatable tube of a roll-up shade. Or, the adaptor 56 may be engaged in any other suitable way with the actuator 12.

As can be appreciated in reference to Figure 2, the motor 44, gear train, coupling 52, and actuator 12 can be oriented coaxially with each other, and the axis is horizontal when the motorized window covering 10 is installed as intended. It can be further appreciated that the weight of the mechanical subset established at least in part by the motor and gear train can be at least partially shared between two noise dampening couplings, i.e., between two elastic coupling devices.

Details of one embodiment of the rotatable noise dampening coupling 52 may be seen in Figure 3, it being understood that the same principles apply to the non-rotatable noise dampening coupling established by the slots 42 in the tube 38. It may be appreciated in reference to Figure 3 that the coupling 52 may be a rigid hard plastic cylinder in which the slots 54 have been formed during molding, or subsequently, by cutting or machining the slots 54 in the coupling 52. Each slot 54 extends completely through the wall of the cylindrical body of the coupling 52, i.e., from the outer surface of the coupling through the inner surface as shown. Also, the slots are oriented perpendicularly to the axis of the coupling as shown.

Two slots 54 preferably are formed at the same axial location of the coupling, radially opposite each other, with each slot of a pair extending around the circumference of the coupling about 150 degrees. Consequently, the slots 54 in a pair are separated by a pair of lands 56 as can be appreciated in the isometric view of Figure 3, with the lands 56 that are associated with a single pair of slots 54, like the slots themselves, being

- 9 -

opposed to each other by 180 degrees. Furthermore, in the embodiment shown in Figure 3 successive pairs of slots 54 (and, hence, each successive pair of associated lands 56) preferably are radially staggered from each other by 90 degrees. With this structure, the noise dampening coupling of the present invention is somewhat flexible about its longitudinal axis but is substantially resistant to twisting under the influence of torque about its longitudinal axis. Importantly, the present noise dampening coupling absorbs vibrations, to minimize transmission of vibrations from the motor 44 to the head rail 20 and, hence, to reduce the noise that emanates from the system during operation. The present coupling can be considered to be an elastic coupling device.

Other well-known elastic couplings may be used, even allowing a limited torsion when submitted to the rated torque conditions. For instance a 15° to 45° torsion may be admitted under rated torque. This can be achieved by means of metallic springs, as a spiral spring, or with viscoelastic couplings.

Figure 4 shows another embodiment of the noise-dampened motor and gear train assembly, generally designated 34a, which provides two pair of noise dampening couplings instead of the single pair shown in Figure 2. As shown, the noise-dampened motor and gear train assembly 34a in Figure 4 includes a motor 44a coupled to a gear train in a housing 50a, with the output gear being coupled to a rotatable noise dampening coupling 52a. The components 34a, 44a, 50a, 52a thus far described in Figure 4 are in all essential respects identical to the corresponding components 34, 44, 50, 52 described in Figure 2, with the exception that the rotatable noise dampening coupling 52a shown in Figure 4 has a single spiral-shaped slot extending continuously around the circumference of the coupling from near one end of the coupling 52a to near the opposite end of the coupling 52a for multiple turns as shown. Like the noise dampening coupling shown in Figure 3, the noise dampening coupling 52a shown in Figure 4 is somewhat flexible about its longitudinal axis but is substantially resistant to twisting under the influence of torque about its longitudinal axis.

- 10 -

In contrast to the noise-dampened motor and gear train assembly 34 shown in Figure 2, in the assembly 34a shown in Figure 4 the motor 44a, gear train housing 50a, and rotatable noise dampening coupling 52a are disposed in a relatively heavy, preferably metal steel or Iron tube 58 to further reduce the sound of operation of the system. One end of the non-rotatable tube 58 is blocked (except for electrical leads) by a sound plug 60, with a first non-rotatable noise dampening coupling 62 being affixed to the end of the tube 58. Also, the first non-rotatable noise dampening coupling 62 is affixed to a mount 40a that in turn is affixable to the inside of the head rail 20 shown in Figure 1.

In further contrast to the noise-dampened motor and gear train assembly 34 shown in Figure 2, in the assembly 34a shown in Figure 4 the rotatable noise dampening coupling 52a is a first rotatable noise dampening coupling, and it is attached, by a shaft 64 that extends through a bearing 66, to a second rotatable noise dampening coupling 68. The bearing 66 fits inside the end of the tube 58 that is opposite the mount 40a. The second rotatable noise dampening coupling 68 may be configured substantially identically to the rotatable noise dampening coupling 52 shown in Figure 2 as shown, although it is to be understood that it may have a spiral-shaped groove like the first rotatable coupling 52a shown in Figure 4 if desired. In any case, the second rotatable noise dampening coupling 68 is engaged with an adapter 56a that is in all essential respects identical to the adapter 56 shown in Figure 2. The noise dampening efficiency of the embodiment depicted in Figure 4 comes from the internal suspension of the geared motor inside a rigid structure comprising mainly a non-rotatable tube 58.

In accordance with the embodiment shown in Figure 4, the non-rotatable noise dampening coupling 62 is a first non-rotatable noise dampening coupling, and a second non-rotatable noise dampening coupling 70 surrounds the first rotatable noise dampening coupling 52a and is in an abutting relationship with the bearing 66. Accordingly, the first rotatable noise dampening coupling 52a rotates within the second

- 11 -

noise dampening coupling 70 when the motor 44a is energized. The second noise dampening coupling 70 may be configured with a single spiral slot or plural slots as shown in the coupling depicted in Figure 3.

In a variant of this embodiment, the second internal elastic coupling 70 is inserted between the motor casing and the rigid non-rotatable tube 58 and blocks the free rotation of the motor casing, allowing small displacements around equilibrium position. In any case, the displacement of the mechanical subset is limited by special parts (e.g., the heavy tube 58) or by the exterior tube/head rail, which prevents any damage due to shocks or large movements during installation.

Figure 5 shows yet a third embodiment of the noise-dampened motor and gear train assembly, generally designated 34b, which, like the assembly 34a shown in Figure 4, provides two pair of noise dampening couplings instead of the single pair shown in Figure 2. As shown, the noise-dampened motor and gear train assembly 34b in Figure 5 includes a motor 44b coupled to a gear train in a housing 50b, with the output gear being coupled to a rotatable noise dampening coupling 52b. The components 34b, 44b, 50b, 52b thus far described in Figure 5 are in all essential respects identical to the corresponding components 34, 44, 50, 52 described in Figure 2, with the exception that the rotatable noise dampening coupling 52b shown in Figure 5 can have a single spiral-shaped slot as shown.

Also like the assembly 34a shown in Figure 4, in the assembly 34b in Figure 5 the motor 44b, gear train housing 50b, and rotatable noise dampening coupling 52b are disposed in a relatively heavy, preferably steel or Iron non-rotatable tube 58b that has one end blocked (except for electrical leads) by a sound plug 60b and that has a first non-rotatable noise dampening coupling 62b affixed to this end of the tube 58b. Also, the first non-rotatable noise dampening coupling 62b is affixed to a mount 40b that in turn is affixable to the inside of the head rail 20 shown in Figure 1. Moreover, in the

- 12 -

assembly 34b shown in Figure 5 the rotatable noise dampening coupling 52b is a first rotatable noise dampening coupling, and it is attached, by a shaft 64b that extends through a bearing 66b to a second rotatable noise dampening coupling 68b. The second rotatable noise dampening coupling 68b is engaged with an adapter 56b that is in all essential respects identical to the adapter 56 shown in Figure 2.

Due to the high rigidity (stiffness) of the non-rotatable tube 58b, both internal elastic couplings 52b and 70b are used very efficiently.

Thus far, the assembly 34b shown in Figure 5 is substantially identical to that shown in Figure 4. Furthermore, while the non-rotatable noise dampening coupling 62b is a first non-rotatable noise dampening coupling, a second non-rotatable noise dampening coupling 70b is disposed in the heavy tube 58b between the motor 44b and the first non-rotatable noise dampening coupling 62b that is outside the heavy tube 58b and that is attached to one end thereof. Accordingly, the first non-rotatable noise dampening coupling 62b attaches the heavy tube 58b to the mount 40b of the head rail 20, while the second non-rotatable noise dampening coupling 70b attaches the motor 44b to the sound plug 60b within the heavy tube 58b, providing yet further sound isolation of the motor 44b.

Figure 6 shows yet a fourth embodiment of the noise-dampened motor and gear train assembly, generally designated 34c, which provides only a single pair of internal noise dampening couplings to suspend the mechanical subset comprising the motor inside a rigid non-rotatable tube 59. As shown, the noise-dampened motor and gear train assembly 34c in Figure 6 includes a motor 44c coupled to a gear train in a housing 50c, with the output gear being coupled to a rotatable noise dampening coupling 52c. In turn, the coupling 52c is coupled to an output rod or tube wheel or output shaft 53c. The components 34c, 44c, 50c, 52c thus far described in Figure 6 are in all essential

- 13 -

respects identical to the corresponding components 34, 44, 50, 52 described in Figure 2.

Also, in the assembly 34c in Figure 6 the motor 44c and gear train housing 50c (but not the rotatable noise dampening coupling 52c) are disposed in a preferably steel or Iron tube 58c that has one end blocked (except for electrical leads) by a sound plug 60c and that has a first non-rotatable noise dampening coupling 62c affixed to this end of the tube 58c. Also, the first non-rotatable noise dampening coupling 62c is affixed to a stationary mount 40c that in turn is fixed to the inside of an external tubular envelope 59 of, e.g., a component having such an envelope.

In one non-limiting embodiment the tubular envelope 59 may be cylindrical to obtain high stiffness properties, and it may be made of steel or Iron with a wall thickness of 1mm to 2mm. If desired, a bearing 63 may be connected between the output shaft 53c and the tubular envelope 59.

The power-drive device depicted in Figure 6 is then protected by its external envelope 59. It will be appreciated that this envelope 59 establishes a natural boundary for the displacement of the suspended mechanical subset in case of shocks during transportation or installation. That is, an advantage of an external tubular envelope 59 in Figure 6 is that a tube, and even more a cylinder, has intrinsically a high rigidity. The mechanical subset including the motor and gear train is suspended inside this tube which acts as a high rigidity supporting member and which is very stable, thereby preventing coupling the resonant frequencies which would otherwise reduce the efficiency of the elastic couplings when the supporting member itself does not have a sufficient mass and/or rigidity. The same remark applies to the non-rotatable rigid tube 58 in Figure 4, and to the non-rotatable rigid tube 58b in Figure 5.

- 14 -

In these figures, the couplings that allow the elastic suspension of the subset, including the motor, inside the tube 58 or 58b are then considered as the "main couplings".

In addition, in some non-limiting embodiments significant advantages may be realized when the assembly includes a rotatable tube, upon which is rolled a screen, an awning or even a roller shutter.

More specifically, in reference to Figure 7, a noise-dampened motor and gear train assembly, generally designated 34d, is disposed within a rotatable tube 12d. It is to be understood that the assembly 34d includes a motor and gear train assembly that is suspended inside the housing of the assembly 34d by one or more of the above-described couplings, e.g., the assembly 34d with motor head or mount 40d could be established by the assembly 34c/element 40c shown in Figure 6, or by the assembly 34 with element 40 shown in Figure 1.

The rotatable tube 12d extends between opposing side walls of a window frame 22d as shown. The tube 12d may be mounted to the window frame 22d by connecting the stationary mount (or equivalently, motor head end) 40d to a first support 73, with the first support in turn being affixed to the window frame 22d near the top of the window frame. Alternatively if desired, the bearing 71 can be directly mounted between the rotatable tube 12d and the first support 73 but it is usually preferred to implement this bearing function as part of the power-drive device 34d. Also, a second support 74 is disposed within the tube 12d and is affixed to the window frame 22d, opposite the first support 73. The mount 40d is surrounded by a first bearing 71 which rotates with the tube 12d, while the second support 74 is surrounded by a second bearing 72 that also rotates with the tube 12d. The bearings 71, 72 ride on the mount/support 40d, 74, respectively as the tube 12d turns.

- 15 -

As mentioned above, the assembly 34d includes a suspended (by one or more of the present couplings) motor and gear train assembly having an output shaft in accordance with previous disclosure, and an adapter 56d that in all essential respects can be identical to the adapter 56 shown in Figure 2 is engaged with the output shaft of the assembly 34d. A wheel 75 is engaged with the adaptor 56d. In accordance with the embodiment of Figure 7, the wheel 75 is also engaged with the rotatable tube 12d, so that the tube 12d rotates when the assembly 34d is energized.

In the embodiment shown in Figure 7, the bearings 71, 72 and the wheel 75 preferably are made of hard materials. Absent suspending the motor and gear train within the assembly 34d as contemplated herein, undamped solid-borne vibrations could otherwise propagate from the motor of the assembly 34d towards the rotatable tube 12d, which in turn would undesirably radiate the vibrations. Previous solutions to this noise problem included the use of soft materials for the bearings 71, 72 and wheel 75, or even for the supports 73, 74, but as understood herein the use of soft materials is less than optimum because these parts must bear the whole weight of the window covering, and elasticity must be maintained quite low. A non-limiting advantage of the invention of Figure 7 is that only the mechanical subset including the motor and gear has to be suspended by elastic parts. Then, the stiffness of the elastic couplings can be much lower and the efficiency of the dampening is dramatically improved.

- 16 -

CLAIMS:

1. An electrical power-drive device for movable window covering and/or screen, awning, roller-door, roller-shutter, comprising:

a mechanical subset including at least one motor;

a first output shaft;

at least one stationary mount;

wherein the subset is elastically coupled by at least a first main rotatable elastic coupling means to the first output shaft and by a second main non-rotatable elastic coupling means to a non-rotatable tube enclosing the subset, the tube being connected to the stationary mount and guiding the first output shaft.

2. The device according to claim 1, wherein the subset includes one gear.

3. The device according to claim 1 or 2, wherein the first output shaft is connectable to at least one of: a rotatable tube, and a rod.

4. The device according to any one of claims 1 to 3, wherein the weight of the subset is at least partially shared between the first and second main elastic coupling means.

5. The device of any of claims 1 to 4, wherein the first output shaft is connected to the tube via a bearing.

6. The device of any of claims 1 to 5, wherein the tube has a cylindrical shape.

- 17 -

7. The device of any of claims 1 to 6, wherein the first output shaft is elastically coupled to a second output shaft via at least a first auxiliary elastic coupling means.

8. The device of any of claims 1 to 7, wherein the tube enclosing the subset is elastically coupled to the stationary mount via at least a second auxiliary elastic coupling means.

9. The device of any of claims 1 to 8, wherein the subset comprises means for controlling the supply of the motor.

10. The device of any of claims 1 to 9, wherein at least one of the elastic coupling means comprises a tube provided with at least a slot.

11. The device of any of claims 1 to 10, wherein at least one of the elastic coupling means is of the energy dissipative type.

12. The device of any of claims 1 to 11, wherein at least one of the elastic coupling means comprises a viscoelastic material.

13. The device of any of claims 1 to 12, wherein at least one of the elastic coupling means is anisotropic.

14. The device of any of claims 1 to 13, wherein at least one of the elastic coupling means is a spiral spring.

15. The device of any of claims 1 to 14, which comprises at least an abutment to limit the displacement of the subset relatively to the stationary mount.

WO 2005/090736

PCT/IB2005/000655

- 18 -

16. A powered assembly, comprising an electrical power-drive device according to any one of claims 1 to 15, the device being coupled to a movable object.

17. The powered assembly of claim 16, wherein the axis of the subset is oriented horizontally.

18. The powered assembly of claim 16 or 17, wherein the movable object is a window covering or a solar screen or a projection screen or an awning or a roller shutter.

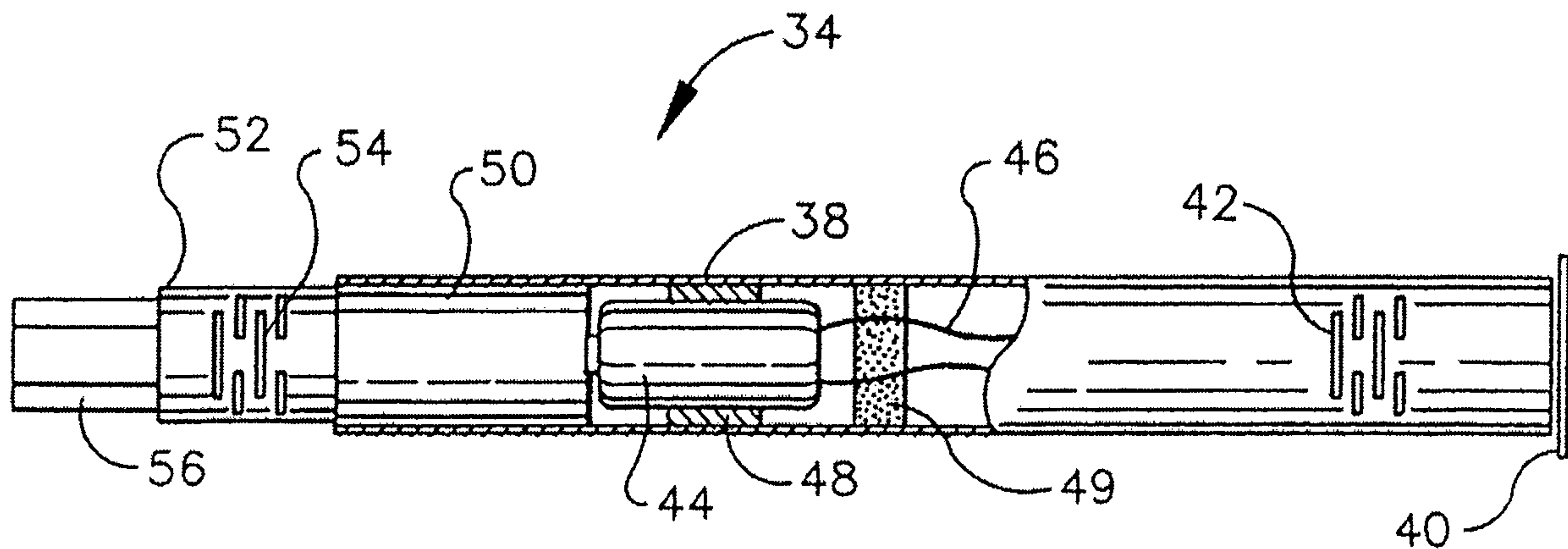
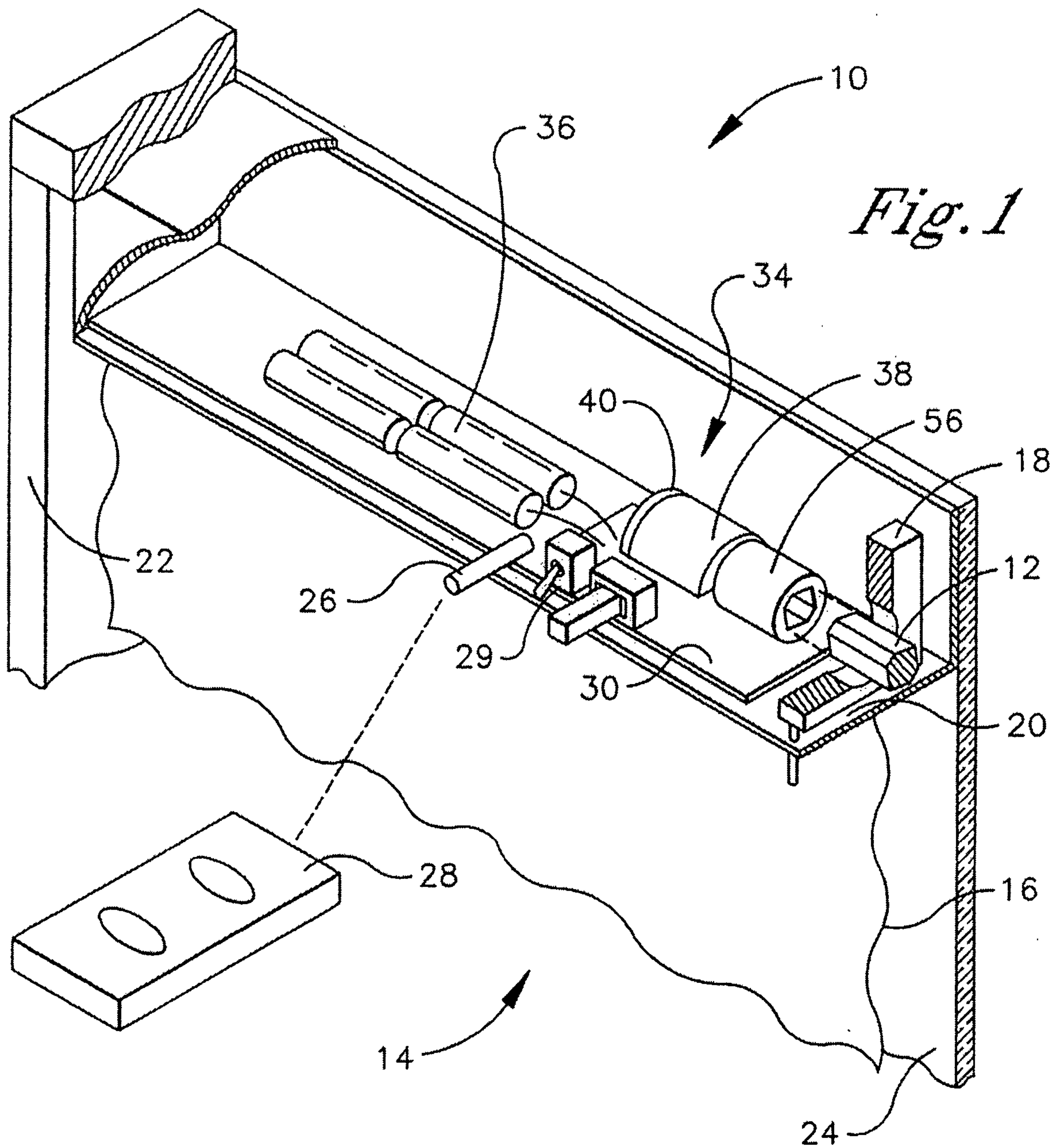

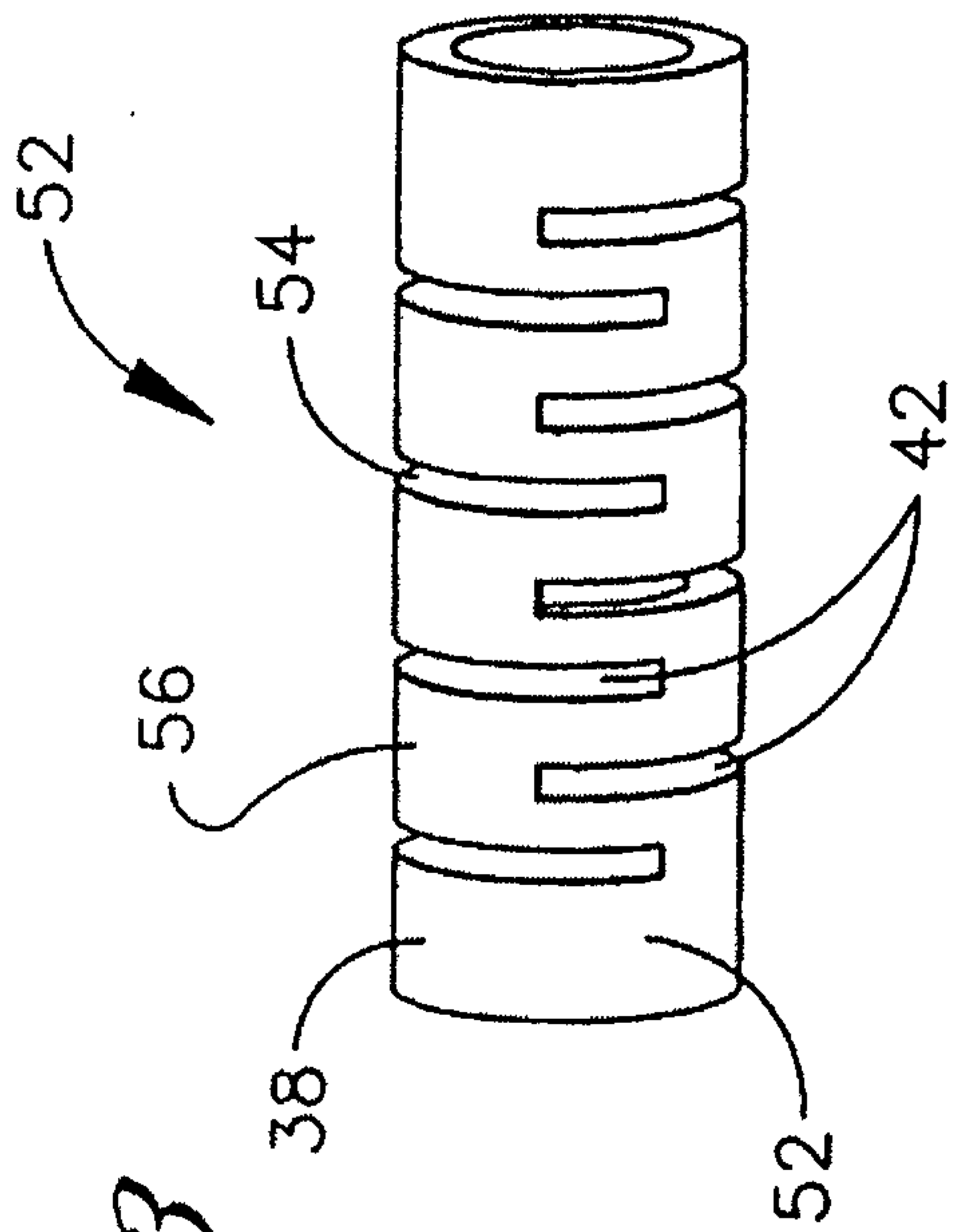

Fig. 3

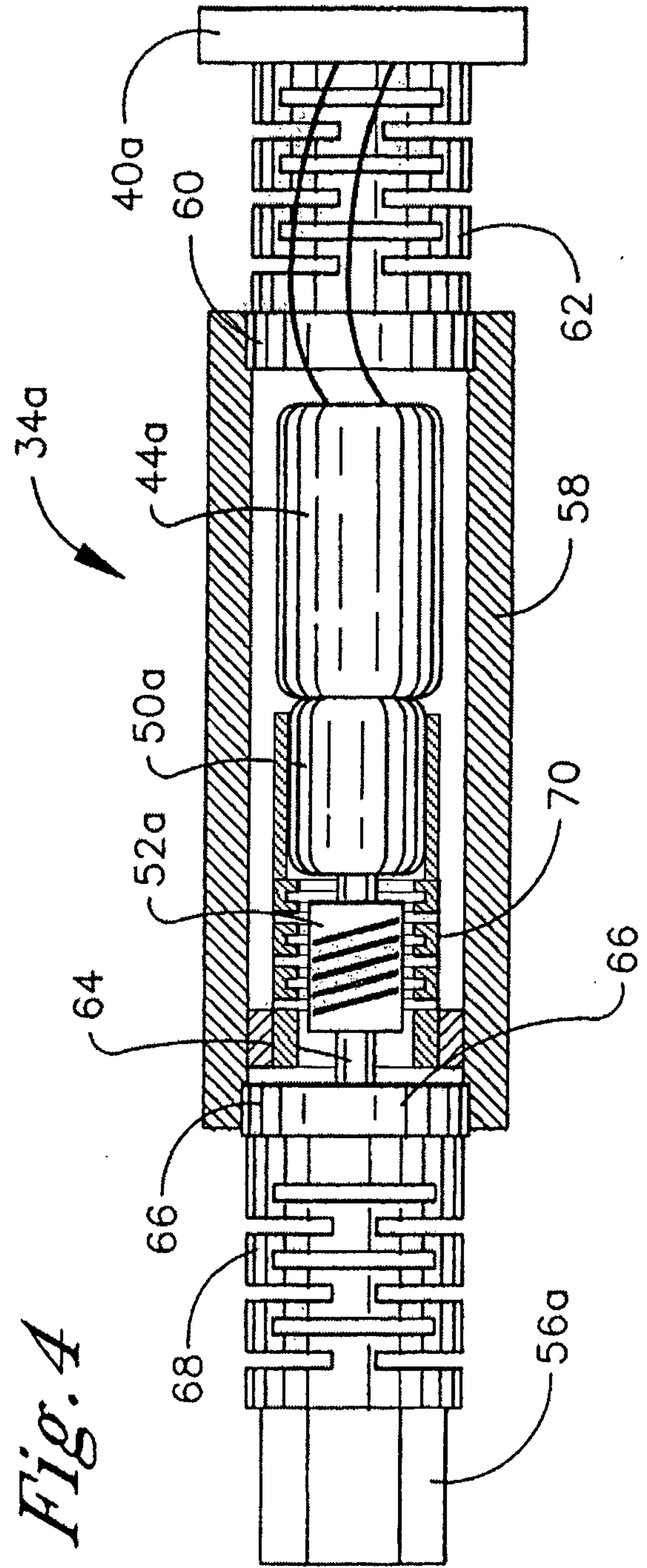
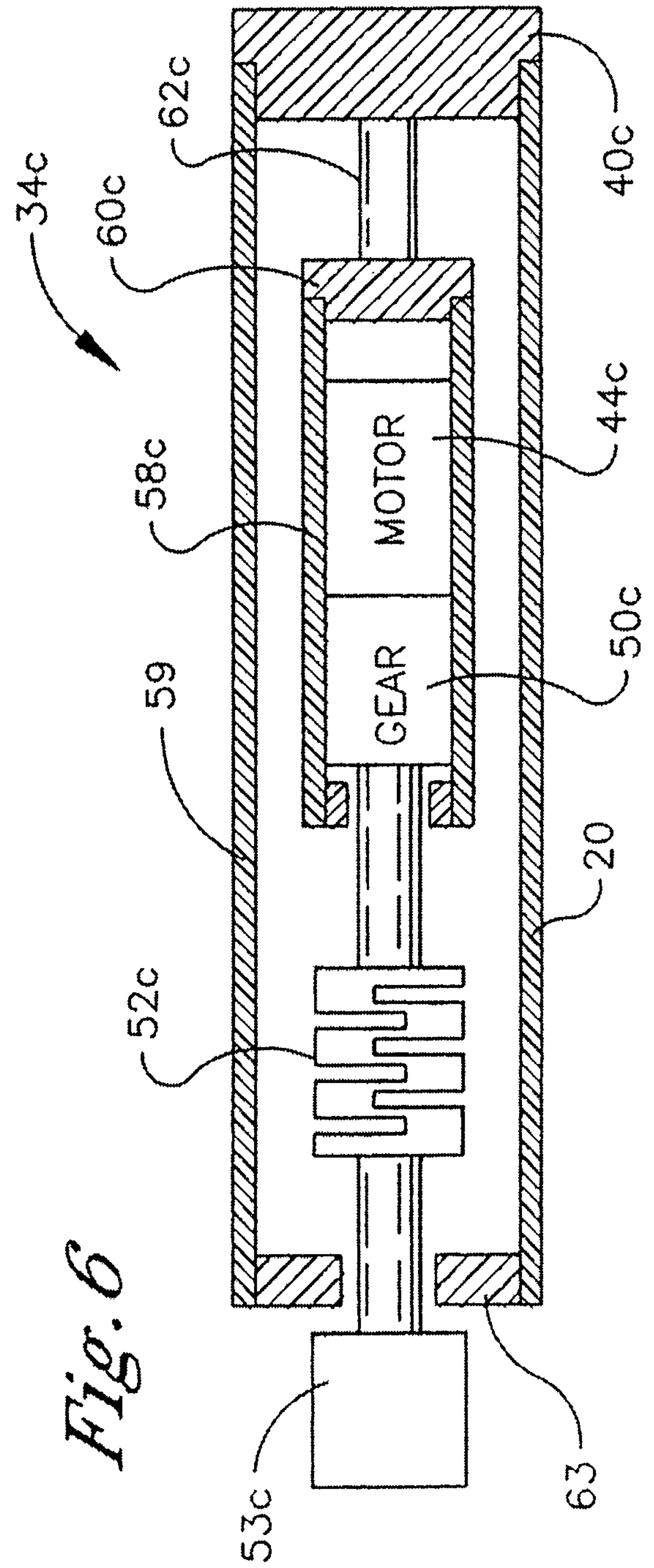
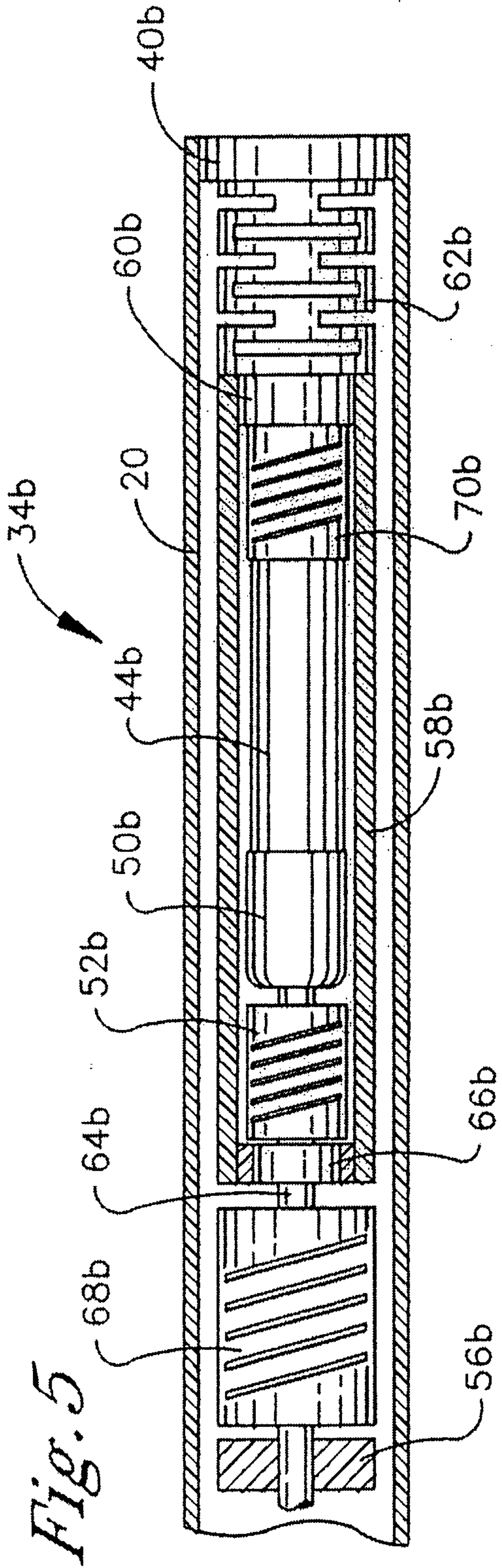

Fig. 4



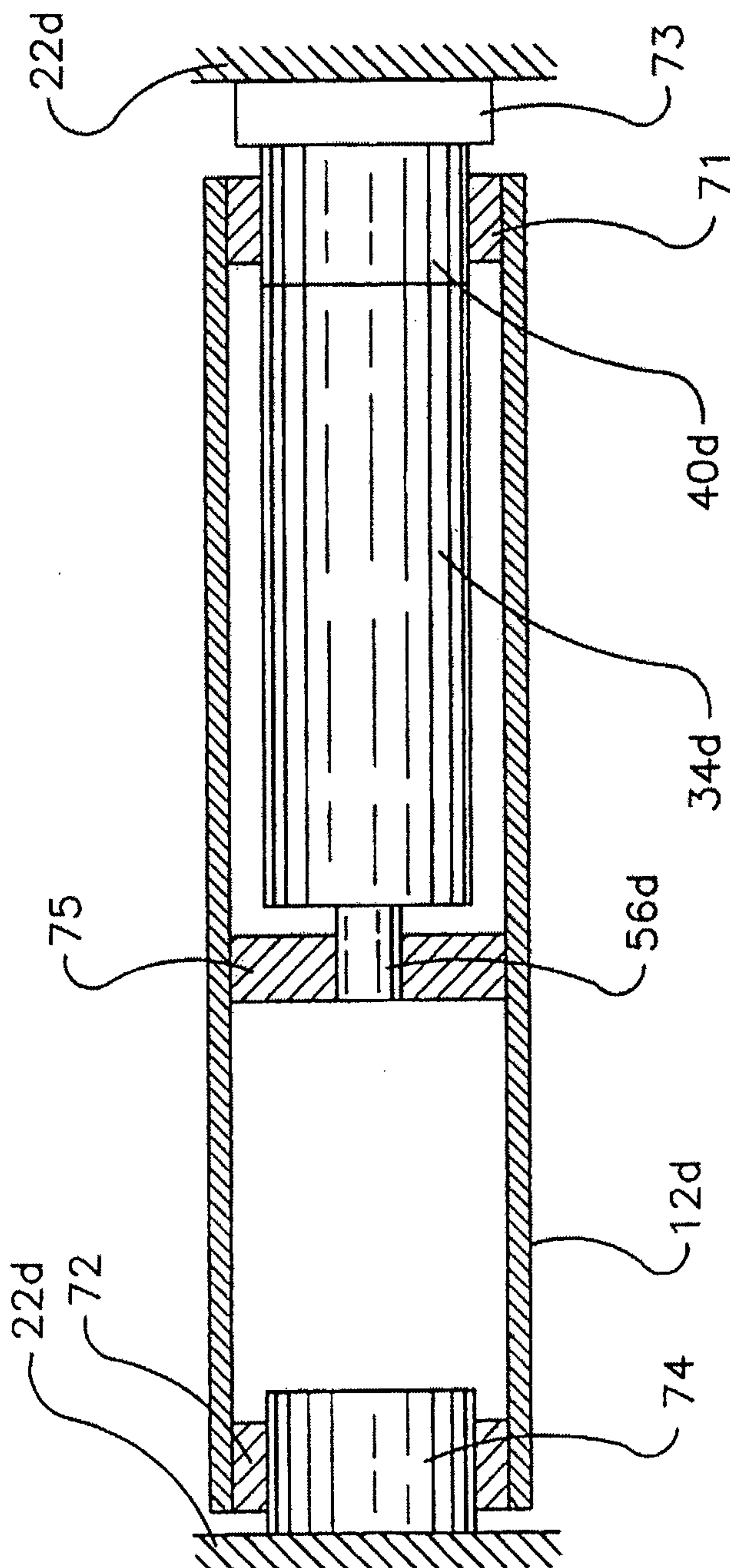

Fig. 7

