

E. EGLI.

THREAD CUTTING MECHANISM FOR WEFT REPLENISHING LOOMS.

APPLICATION FILED MAY 27, 1913.

1,104,880.

Patented July 28, 1914.

2 SHEETS-SHEET 1.

Fig. 1

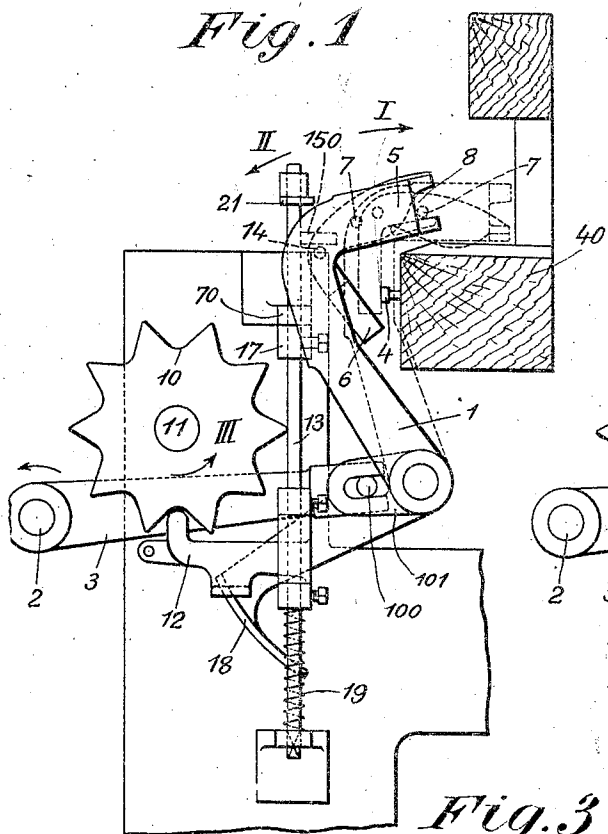

Fig. 2

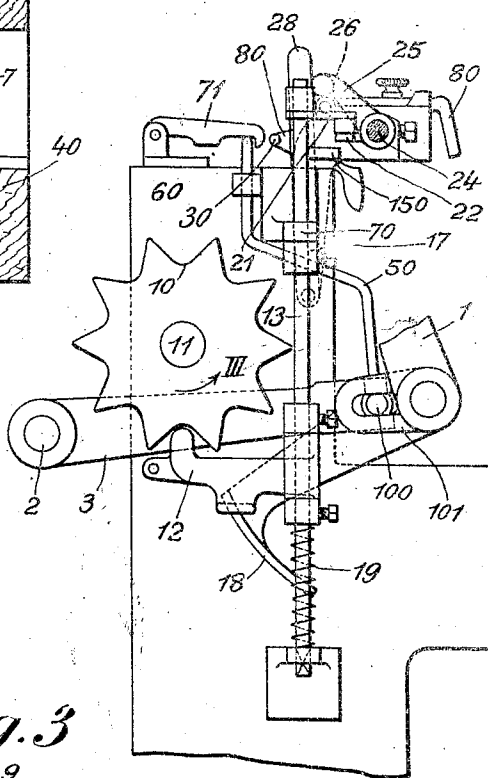
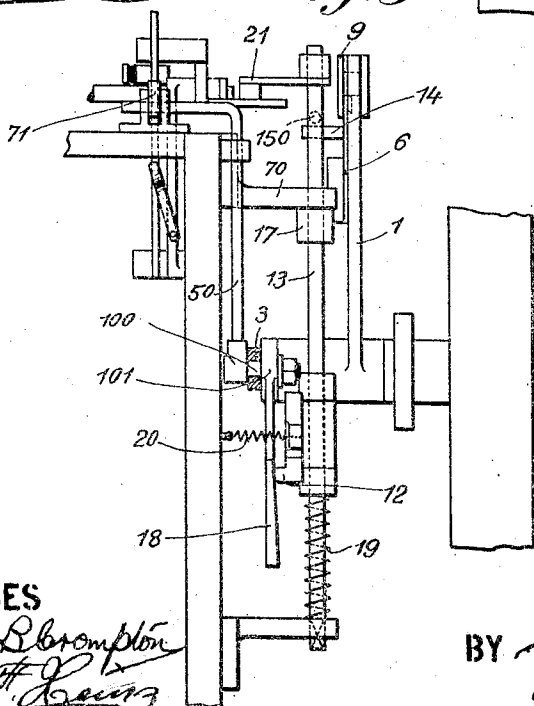

Fig. 3



WITNESSES

Charles Brompton
John H. Lewis

EDUARD EGLI.
INVENTOR

BY *Graydon Marks*
ATTORNEY

E. EGLI.
 THREAD CUTTING MECHANISM FOR WEFT REPLENISHING LOOMS.
 APPLICATION FILED MAY 27, 1913.

1,104,880.

Patented July 28, 1914.

2 SHEETS—SHEET 2.

Fig. 4

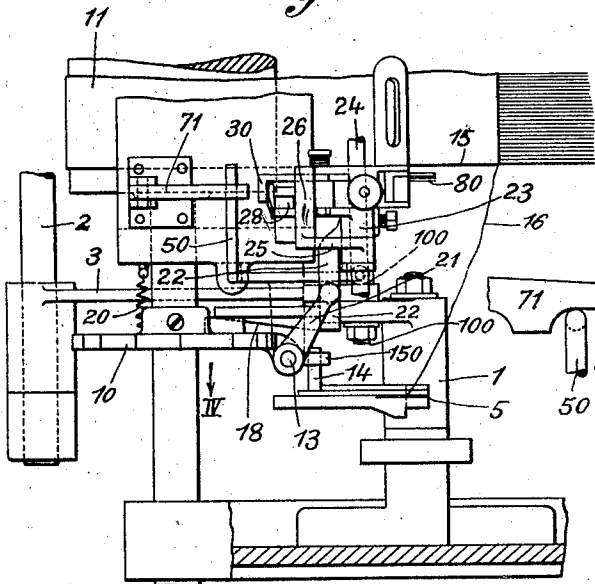

Fig. 5

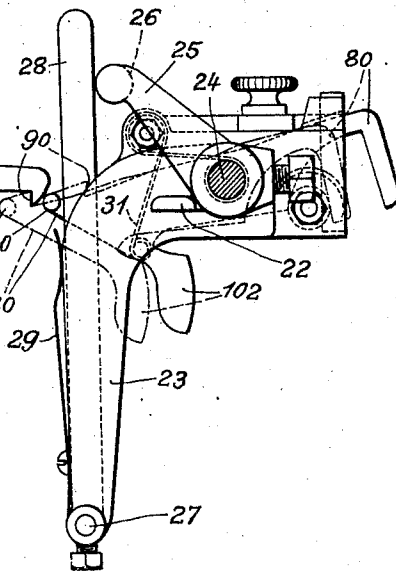

Fig. 7

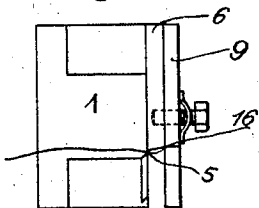
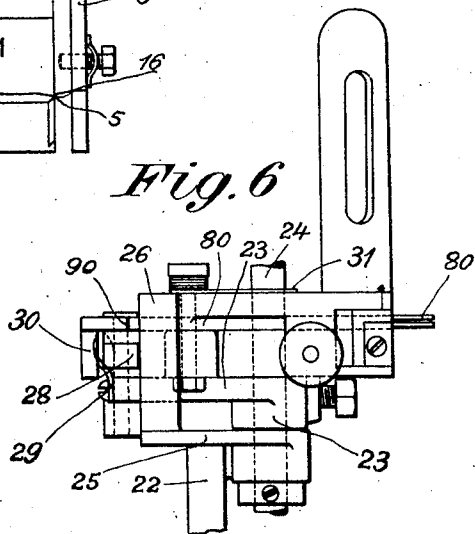

Fig. 6



EDUARD EGLI.
 INVENTOR

WITNESSES

Charles D. Brompton
John H. Keena

BY *E. Boydston Marks*
 ATTORNEY

UNITED STATES PATENT OFFICE.

EDUARD EGLI, OF RÜTI, SWITZERLAND, ASSIGNOR TO MASCHINENFABRIK RÜTI
FORMERLY CASPAR HONEGGER, OF RÜTI, SWITZERLAND.

THREAD-CUTTING MECHANISM FOR WEFT-REPLENISHING LOOMS.

1,104,880.

Specification of Letters Patent.

Patented July 28, 1914.

Application filed May 27, 1913. Serial No. 770,257.

To all whom it may concern:

Be it known that I, EDUARD EGLI, a citizen of the Republic of Switzerland, residing at Rüti, in the Canton of Zurich, Republic of Switzerland, have invented certain new and useful Improvements in Thread-Cutting Mechanism for Weft-Replenishing Looms; and I do hereby declare the following to be a full, clear, and exact description of the invention, such as will enable others skilled in the art to which it appertains to make and use the same, reference being had to the accompanying drawings, and to letters of reference marked thereon, which form a part of this specification.

This invention has for its object to provide an improved thread cutting mechanism for weft replenishing looms, and means for stopping the temple thread cutter between two operations for replenishing the weft thread.

The actual purpose of the invention is to avoid with complete certainty the accidental weaving in of the ends of severed threads in the fabric, whereby weaving faults and defects are occasioned, and to impart to the temple thread cutter before its stoppage a sufficient number of cutting movements for effecting the certain severing of the thread or threads.

One embodiment of this invention is illustrated by way of example in the accompanying drawings, in which the same reference numerals refer to the same parts.

Figure 1 is a right hand side elevation of those parts of the apparatus whose function it is to open the shears mounted on the shuttle feeler, Fig. 2 is a similar elevation of the parts of the apparatus for stopping the temple thread cutter. Fig. 3 is a front elevation of the improved apparatus. Fig. 4 is a plan thereof. Figs. 5 and 6 are views on a larger scale of parts shown in Figs. 2 and 4; and Fig. 7 is a rear elevation on a larger scale of the shears mounted on the shuttle feeler.

1 is the lever which is actuated by the shuttle feeler and which is moved toward the rear in the direction of the arrow I, Fig. 1, by means of the operating shaft 2 for the weft replenishing motion with the aid of the fork lever 3 from the position of rest shown in full lines into the operative position shown in dotted lines, just before the

spool is changed in the shuttle. The fork lever 3 embraces a pin 100, of a second arm 101 of the shears lever 1. The shears 5 are closed in the usual manner by a stop 4 on the slay 40. In this movement the shears blade 6 which is pivoted by means of a pin 7 on the shears lever 1, severs the thread which enters the opening 8 of the shears on the return of the shears and of the lever 1.

The end of the thread length 16 extending to the edge of the fabric 15 (Figs. 4 and 7) is clamped, before being cut, between the rounded edge of the shears blade 6 and the resiliently pressing plate 9. After the changing of the shuttle spool the shears move forward while closed together with the gripped thread into the normal or rest position (as indicated by the arrow II, Fig. 1), and is positively opened after the delivery beam 11 has been rotated about 10 to 30 mm. in the forward direction according to the rotary position of the star wheel 10 fixed on the axle of the delivery beam 11. This is effected as follows:—The star wheel 10 in rotating in the direction of the arrow III (Fig. 1) presses down a lever 12 and a rod 13 upon which the lever 12 is arranged to rotate but is incapable of axial motion. A cross pin 150 of the rod 13 engages with the upper end of a pin 14 of the movable blade of the shears mounted on the shuttle feeler, whereby the shears are caused to open on the descent of the lever 12 and the rod 13. The advantage of opening the shears in their position of rest consists in that the thread length 16 extending from the shears 5 on the shuttle feeler to the selvage 15 of the fabric is not released by the shears immediately after the changing of the spool and also not immediately before the said changing. The said release takes place only shortly after the shears on the temple has cut the thread at the selvage 15. The opening of the shears on the shuttle feeler in the normal or rest position of its carrier has the result that the thread length 16 can never come to lie upon the shuttle race of the slay, and therefore it is quite impossible for this length of thread to be drawn by the shuttle into the fabric.

In order that the rod 13 shall resume immediately after each change of spool, its upper position limited by a set collar 17 and a fixed stop 70, the lever 12 is shifted sidewise at each return oscillation (arrow

1) of the shears lever 1, by an inclined surface 18 of the lever 1 (arrow IV, Fig. 4) and is thereby moved out of the range of the star wheel 10. If the rounded end of the lever 12 is situated at the instant of the change of spool, under a tooth of the star wheel 10, the lever 12 will be disengaged by the inclined surface 18 and will be moved by a spring 19, and rod 13 into its top position. Then as soon as the next tooth space of the star wheel 10 is brought by the continued rotation of the latter in front of the rounded end of the lever 13, this lever will be drawn by a spring 20 back under the wheel 10 and the next tooth of the latter wheel will cause the rod 13 to move down, and thus open the shears by pressing upon the pin 14 of the movable blade 6 of the shears mounted on the shuttle feeler.

On the pin 100 of the shears lever 1, there is pivoted a rod 50 (Figs. 2, 3, 4 and 5) the horizontally bent end of which engages with the underside of a pawl 71 mounted on the front of the loom framing 60. This pawl is designed to engage in a notch 90 provided in the movable cutting blade 80 (Figs. 2, 5 and 6) of the temple thread cutter, and thus hold the blade 80 in its position of rest, in which its tongue 102 can not be reached by the slay as hereinafter described.

The upper end of the rod 13 (Figs. 2, 3 and 4) carries an inwardly inclined transverse arm 21, which presses upon an arm 22 of a bell crank lever 22, 25 which is pivoted on the fixed bar 24 that carries the temple thread cutter and a supporting arm 23. The other arm 25 of the bell crank lever has a finger 26 which presses upon a rocking bar, 28, mounted at 27 in the supporting arm 23. A spring 29 presses the bar 28 against the finger 26 and returns the bell crank lever 22, 25 into its normal position. The bar 28 is situated behind a cross pin 30 of the movable blade 80 (which is driven backward by the spring 31) of the temple thread cutter.

The pawl 71 is disengaged by the rocking (produced by the fork lever 3) of the shears lever 1 in the direction of the arrow I (Fig. 1), and the consequent rise of the rod 50 (Figs. 2 and 5). The spring 31 now moves the movable blade 80 of the temple thread cutter from its position shown in dash-dot lines (Fig. 5) into the position shown in full lines in which the slay of the loom can press upon the tongue 102 of the shears blade 80 of the temple thread cutter and thus actuate the latter in the usual way, so that any threads that are inserted in these shears are severed.

After the severing of the threads the temple thread cutter continues to move until the star wheel 10 has depressed the rod 13 by means of the lever 12, and the arm 21 has moved the bell crank lever 22, 25 forward. According to the position of the star

wheel 10 with relation to the lever 12, at the instant of the changing of the spool, the movable shear blade 80 makes 10 to 50 further cutting movements before it comes to rest. By this means it is insured that the thread or threads shall be severed in any case, for instance, even when the shear blades are blunt. When the rod 13 is lowered the finger 26 presses upon the rocking bar 28 and the latter presses upon the pin 30 of the movable shear blade 80. The notch 90 in this blade is thereby moved forward to such an extent as to allow the pawl 71 to engage this notch 90 and hold the blade 80 fast, in a position in which the slay cannot reach the tongue 102. By this means the temple thread cutter remains at rest until the next changing of the spool or shuttle, whereby the shears are saved from a considerable amount of wear and tear.

For the purposes of this invention, the automatic replenishment of the weft spools is to be understood as including the automatic replenishment of the spools, as well as that of the shuttles. Consequently the advantages of the improved apparatus consist first in that the severed threads are moved with certainty out of the reach of the shuttle so that a weaving in of such threads is rendered impossible; secondly in that the temple thread cutter is caused by a sufficient number of cutting movements, before coming to rest, to cut the thread or threads with certainty even when the shear blades are no longer sharp; and thirdly in that only the movable blade of the temple thread cutter is moved into the rest position and also independently of the slay. This construction of the apparatus without forward movement of the whole temple thread cutter, secures a steady working of the apparatus with a minimum of friction.

What I claim is:—

1. In a loom with automatic weft replenishment, the combination of shuttle-feeler shears, a plate resiliently pressed against the movable blade of the shuttle feeler shears, means for positively opening the said shears in the normal or rest position of the shears carrier and means for stopping the movable blade of the temple thread cutter during the time comprised between two replenishments of the weft thread.

2. In a loom with automatic weft thread replenishment, the combination of a forked lever fixed on the controlling shaft for the weft replenishing mechanism, a shuttle feeler shears lever having a cross pin embraced by said fork, a star wheel adapted to be rotated from a member of the loom, a vertically and horizontally movable arm, adapted to be brought into engagement with said star wheel by means of a spring, a vertically movable rod carrying said arm, being pressed up resiliently and provided with

a cross pin in the upper part, a movable blade of the shuttle feeler shears adapted to be operated by means of said pin engaging a pin on said blade, a shears lever arm
 5 having an inclined surface for disengaging the said arm from said star wheel, on the return stroke of said shuttle feeler shears, and means for stopping the movable blade of the temple thread cutter, during the time
 10 comprised between two weft thread replenishments.

3. In a loom with automatic weft thread replenishment, the combination of a forked lever fixed on the controlling shaft for the
 15 weft replenishing mechanism, a shuttle feeler shears lever having a cross pin embraced by said fork, a star wheel adapted to be rotated from a member of the loom, a vertically and horizontally movable arm
 20 adapted to be brought into engagement with said star wheel by a spring, a vertically movable rod carrying said arm, being pressed up resiliently and provided with a cross pin in the upper part, a movable blade
 25 of the shuttle feeler shears provided with a

pin adapted to be actuated by said pin, an arm of the shears lever with an inclined surface for disengaging said arm from said star wheel on the return stroke of the shuttle
 30 feeler shears, a vertically movable rod, pivoted on the cross pin of the shuttle feeler shears lever, a pawl mounted on the loom framing and adapted to be disengaged by the said rod, a horizontal arm provided on
 35 the resiliently upwardly pressed rod, a bell crank lever adapted to be operated by said last mentioned arm, a rocking bar adapted to bear against a lateral finger of the last mentioned lever, and a pin fixed to the movable
 40 blade of the temple thread cutter, adapted to be driven by said rocking bar forward into the range of the pawl that is mounted on the loom frame.

In testimony whereof, I have signed my
 45 name to this specification in the presence of two subscribing witnesses.

EDUARD EGLI.

Witnesses:

HERMANN HUBER,
 ROGER AMES BURR.