

(No Model.)

C. W. POTTER & J. C. HEWITT.  
BOX LAUNDRY IRON.

No. 524,732.

Patented Aug. 21, 1894.

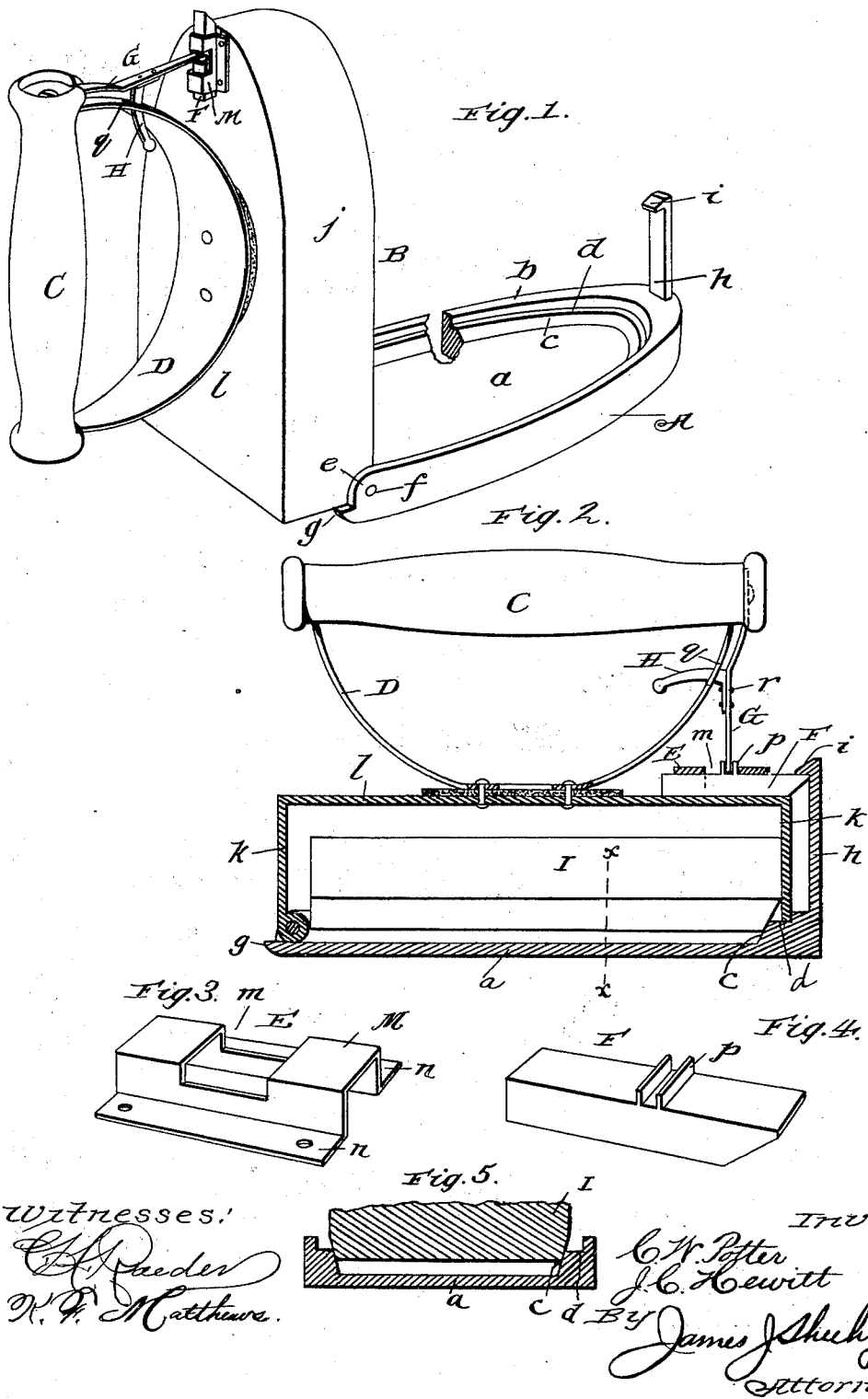

Witnesses:  
*C. A. Prader*  
*N. P. Matthews.*

Inventors  
*C. W. Potter*  
*J. C. Hewitt*  
BY *James J. Shueby*  
Attorney

# UNITED STATES PATENT OFFICE.

CHARLES W. POTTER, OF ATHENS, AND JOHN C. HEWITT, OF MINERAL, OHIO.

## BOX LAUNDRY-IRON.

SPECIFICATION forming part of Letters Patent No. 524,732, dated August 21, 1894.

Application filed May 2, 1894. Serial No. 509,832. (No model.)

*To all whom it may concern:*

Be it known that we, CHARLES W. POTTER, of Athens, and JOHN C. HEWITT, of Mineral, in the county of Athens and State of Ohio, citizens of the United States, have invented certain new and useful Improvements in Box Laundry-Irons; and we do declare the following to be a full, clear, and exact description of the invention, such as will enable others skilled in the art to which it appertains to make and use the same.

This invention relates to improvements in that class of laundry irons in which a heating slug or iron is placed in a hollow box connected by a hinge joint with the base or smoothing plate, and the novelty will be fully understood from the following description and claims when taken in connection with the annexed drawings, in which—

Figure 1, is a perspective view of our improved iron showing the top in a raised position and the heating slug removed. Fig. 2, is a vertical, longitudinal, sectional view of the same with the slug in position. Fig. 3, is a perspective view of the bolt casing removed. Fig. 4, is a perspective view of the slide bolt and Fig. 5, is a detail transverse section taken in the plane indicated by the line  $x, x$ , of Fig. 2.

Referring by letter to said drawings: A, indicates the bottom or base section of our improved iron. This bottom which may be made of steel or other suitable material, and preferably aluminum or an alloy of aluminum and phosphor bronze, is of a peculiar construction, comprising a smoothing plate  $a$ , surrounded by a vertical flange  $b$ , on its margin, and on the inner side of this flange, is a sloping wall  $c$ , which terminates at its upper end in a seat  $d$ , to receive snugly the lower edge of the top section B. The longitudinal side walls of the base or bottom are preferably curved at their rear ends as shown at  $e$ , and are perforated as shown at  $f$ , for a purpose which will presently appear, and the base or smoothing plate is extended at its rear end so as to form a flat shoulder  $g$ . The forward end of the base or bottom section has a central, vertical, latch-post  $h$ , rising therefrom, and this post is provided at its upper end on its inner side with a shoulder or lug  $i$ , to engage the latch of the top.

The top B, is of a form, substantially as

shown, having side walls  $j$ , and closed end walls  $k$ , and also a closed top wall  $l$ . This top is also preferably composed of aluminum or an alloy of aluminum and phosphor bronze, but for the sake of cheapness in manufacture, it may be composed of iron or other suitable material. This top is provided at its rear end in its side walls with perforations to register with the perforations  $f$ , in the bottom section, and bolts or rivets are employed for connecting the two sections in a hinged manner. By the construction described, it will be seen that when the top has been thrown back on the hinge joint, the rear wall  $k$ , will abut against the shoulder  $g$ , of the bottom, so as to support the top in an open position.

C, indicates a handle which may be of wood or other suitable material. This handle is connected to and supported upon the top wall of the top section B, by means of a curvilinear support D. This support D, may be composed of sheet metal and is of a sufficiently broad contour to serve the additional function of a shield for the hand of the operator. This shield and handle support may be connected to the top section of the iron by means of rivets or the like, and a sheet of asbestos, or other suitable non-conductor of heat is interposed between the bottom of the shield, and the top of the iron, and the ends of the shield are let into recesses in the opposite ends of the handle, and there secured by bolts, screws, or other suitable fastening devices.

E, indicates the bolt casing. This casing may be formed from a sheet of steel or other metal, shaped as shown in Fig. 3, of the drawings, with vertically-disposed, angular loops M, separated by an interspace  $m$ , and lateral flanges  $n$ , for attachment to the forward, upper side of the top wall of the section B. It is obvious that the loops may be of a circular or other suitable form, according to the form of bolt employed, and this casing is secured to the iron just in advance of the handle.

F, indicates a slide bolt. This bolt is shown as of an angular form in cross section, but may be of other suitable shape and is designed to be placed in the casing E. The bolt is provided at a suitable point in its length on its upper side with two parallel, vertical flanges  $p$ , to receive between them, the lower

end of a spring lever, as will be presently described, and these flanges will prevent the bolt from entirely leaving the casing, either in a forward or rearward direction.

5 G, indicates a lever. This lever is secured at its upper end in the forward end of the handle which is recessed as shown, and is thence preferably curved toward the shield, and its lower end enters between the two vertical flanges *p*, of the slide bolt so as to move  
10 the same.

H, indicates a finger lever. This finger lever passes through a slot or aperture *q*, in the forward portion of the shield, and extends a sufficient distance within the same to be conveniently manipulated by the finger of the operator. The outer or opposite end of the finger piece is bolted or otherwise secured to the spring lever as shown at *r*, and the slot in the shield is sufficiently long to permit said  
20 finger piece to work freely therein.

I, indicates the heating slug, which may be of the character usually employed in this class of devices. This slug is designed to rest upon the inner sloping walls *c*, of the base or bottom section of the iron, and by reason of the sloping walls, it will be seen that the slug will be prevented from sliding or playing during use of the iron, as when the slug cools and becomes contracted, it will slide down the sloping walls, always holding contact therewith, and as the upper section B, fits snugly within the lower section or base, resting upon the top edge of the sloping walls, a very tight joint will be effected between the two parts, so as to absolutely prevent the escape of any heat from the box formed by said parts.  
30

By having the recesses in the ends of the handle C, and the ends of the shield D, let into said recesses any heat which might be conducted through the shield, will not burn the hand of the operator. The asbestos or other non-conductor of heat employed be-  
40

tween the shield and the iron top will in a measure prevent the heat from being carried through the shield, but there is always more or less heat retained in the metal supporting the handle.

Having described our invention, what we claim is—

1. The bottom section, having the internal, sloping walls, and also having the shoulder at its rear end, and the latch post at its forward end, in combination with the top section hinged to the rear end of the bottom or base section, the handle, secured to the top section by a support which serves the additional function of a shield, and is slotted, the slide bolt, the spring lever, secured at its upper end to the handle, and engaging the slide bolt at its lower end, and the finger piece secured to said lever and passing through the slot of the handle supporting shield, substantially as specified.  
55

2. In a laundry iron, the combination of the base section comprising the plate *a*, and the vertical, marginal flange *b*, having the sloping surface *c*, on its inner side and the seat *d*, at the upper end of said sloping surface and also having the latch post at its forward end and the shoulder *g*, at its rear end, the top section hinged to the rear end of the bottom section and carrying a latch to engage the latch post of the base section and adapted to rest on the seat *d*, of said section when closed and on the shoulder *g*, thereof when open, and a slug adapted to rest on the sloping surface *c*, of the flange *b*, of the bottom section, substantially as specified.  
65

In testimony whereof we affix our signatures in presence of two witnesses.  
75

CHARLES W. POTTER.  
JOHN C. HEWITT.

Witnesses:

W. E. PETERS,  
L. M. JEWETT.  
80