



(51) International Patent Classification:  
A61M 37/00 (2006.01)

(21) International Application Number:  
PCT/US2011/041430

(22) International Filing Date:  
22 June 2011 (22.06.2011)

(25) Filing Language: English

(26) Publication Language: English

(30) Priority Data:  
61/357,582 23 June 2010 (23.06.2010) US

(71) Applicant (for all designated States except US): SEVENTH SENSE BIOSYSTEMS, INC. [US/US]; 286 Cardinal Medeiros Avenue, Cambridge, MA 02141 (US).

(72) Inventors; and

(75) Inventors/Applicants (for US only): CHICKERING, Donald, E., III [US/US]; 3 Holly Way, Framingham, MA 01701 (US). BERNSTEIN, Howard [US/US]; 33 A Trowbridge Street, Cambridge, MA 02138 (US). DAVIS, Shawn [US/US]; 43 Winter Street, Suite 8, Boston, MA 02108 (US). HAGHGOOIE, Ramin [US/US]; 32 Crosby Street, Arlington, MA 02474 (US). LEVINSON, Douglas, A. [US/US]; 91 Lake Street, Sherborn, MA 01770 (US). MICHELMAN, Mark [US/US]; 154 Belmont Street, Reading, MA 01867 (US). GONG, Ping [CN/US]; 1 Oak Grove Avenue, #221, Melrose, MA 02176 (US).

(74) Agent: OYER, Timothy, J.; Wolf, Greenfield & Sacks, P.C., 600 Atlantic Avenue, Boston, MA 02210-2206 (US).

(81) Designated States (unless otherwise indicated, for every kind of national protection available): AE, AG, AL, AM, AO, AT, AU, AZ, BA, BB, BG, BH, BR, BW, BY, BZ, CA, CH, CL, CN, CO, CR, CU, CZ, DE, DK, DM, DO, DZ, EC, EE, EG, ES, FI, GB, GD, GE, GH, GM, GT, HN, HR, HU, ID, IL, IN, IS, JP, KE, KG, KM, KN, KP, KR, KZ, LA, LC, LK, LR, LS, LT, LU, LY, MA, MD, ME, MG, MK, MN, MW, MX, MY, MZ, NA, NG, NI, NO, NZ, OM, PE, PG, PH, PL, PT, RO, RS, RU, SC, SD, SE, SG, SK, SL, SM, ST, SV, SY, TH, TJ, TM, TN, TR, TT, TZ, UA, UG, US, UZ, VC, VN, ZA, ZM, ZW.

(84) Designated States (unless otherwise indicated, for every kind of regional protection available): ARIPO (BW, GH, GM, KE, LR, LS, MW, MZ, NA, SD, SL, SZ, TZ, UG, ZM, ZW), Eurasian (AM, AZ, BY, KG, KZ, MD, RU, TJ, TM), European (AL, AT, BE, BG, CH, CY, CZ, DE, DK, EE, ES, FI, FR, GB, GR, HR, HU, IE, IS, IT, LT, LU, LV, MC, MK, MT, NL, NO, PL, PT, RO, RS, SE, SI, SK, SM, TR), OAPI (BF, BJ, CF, CG, CI, CM, GA, GN, GQ, GW, ML, MR, NE, SN, TD, TG).

Published:

— without international search report and to be republished upon receipt of that report (Rule 48.2(g))

(54) Title: SAMPLING DEVICES AND METHODS INVOLVING RELATIVELY LITTLE PAIN

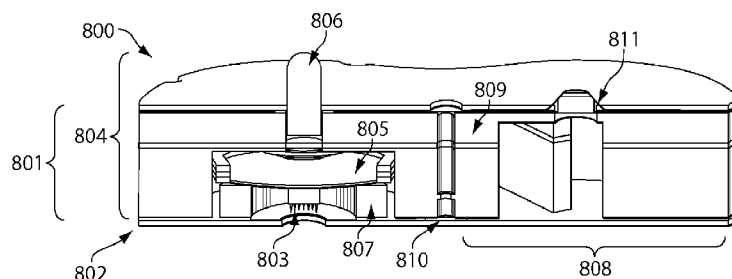

Fig. 15C

(57) Abstract: The present invention generally relates to systems and methods for delivering and/or receiving a substance or substances such as blood, from subjects, e.g., to the skin and/or from the skin. In one aspect, the present invention is generally directed to devices and methods for receiving blood from a subject, e.g., from the skin, using devices including a substance transfer component (which may contain, for example, one or more microneedles), and a storage chamber having an internal pressure less than atmospheric pressure prior to receiving blood. In certain embodiments, substances may be received from and/or delivered to the subject with relatively little pain. The pain may be assessed, for example, using pain scales such as the Wong-Baker FACES Pain Scale. In some cases, the device may be self-contained, and in certain instances, the device can be applied to the skin, and activated to receive blood from the subject. The device, or a portion thereof, may then be processed to determine the blood and/or an analyte within the blood, alone or with an external apparatus. For example, blood may be received from the device, and/or the device may contain sensors or agents able to determine the blood and/or an analyte suspected of being contained in the blood. Other aspects of the present invention are directed to other devices for receiving blood (or other bodily fluids, e.g., interstitial fluid), kits involving such devices, methods of making such devices, methods of using such devices, and the like.



**SAMPLING DEVICES AND METHODS INVOLVING RELATIVELY LITTLE  
PAIN**

**RELATED APPLICATIONS**

5           This application claims the benefit of U.S. Provisional Patent Application Serial No. 61/357582, filed June 23, 2010, entitled “Sampling Devices and Methods Involving Relatively Little Pain,” by Chickering, *et al.* This application is incorporated herein by reference.

**FIELD OF INVENTION**

10           The present invention generally relates to systems and methods for delivering and/or receiving a substance or substances such as blood and/or drugs, with respect to subjects, e.g., at and/or beneath the skin, and in some cases, with relatively little pain.

**BACKGROUND**

15           Phlebotomy or venipuncture is the process of obtaining intravenous access for the purpose of intravenous therapy or obtaining a sample of venous blood. This process is typically practiced by medical practitioners, including paramedics, phlebotomists, doctors, nurses, and the like. Substantial equipment is needed to obtain blood from a subject, including the use of evacuated (vacuum) tubes, e.g., such as the Vacutainer™  
20           (Becton, Dickinson and company) and Vacuette™ (Greiner Bio-One GmbH) systems. Other equipment includes hypodermic needles, syringes, and the like. However, such procedures are complicated and require sophisticated training of practitioners, and often cannot be done in non-medical settings. Accordingly, improvements in methods of  
25           obtaining blood or other fluids from the skin are still needed.

**SUMMARY OF THE INVENTION**

30           The present invention generally relates to systems and methods for delivering and/or receiving a substance or substances such as a drug or blood, with respect to subjects, e.g., at or beneath the skin, and in some cases, with relatively little pain. (As used herein, the phrase “from the skin” is used to mean from the top or outer surface of the skin, from within the skin, and/or from beneath the skin. Likewise, “to the skin” is used to mean to

the top or outer surface of the skin, to within the skin, and/or to beneath the skin.) The subject matter of the present invention involves, in some cases, interrelated products, alternative solutions to a particular problem, and/or a plurality of different uses of one or more systems and/or articles.

5 In one aspect, the present invention is generally directed to a simple, one-piece, low-profile, high acceleration, high energy, actuation mechanism for inserting microneedles (or other objects) into the skin for the purpose of delivering or receiving substances, such as drugs, blood or interstitial fluid. In one set of embodiments, a device of the invention is actuated by a deployment actuator which can provide advantages in ease of operation,  
10 speed of operation, reduction or elimination of pain, etc.

In one aspect, the present invention is generally directed to a device for essentially pain-free receiving of blood or other substance from the skin of a subject, the device having an average pain indication that is significantly less than the pain experienced from a blood sampling using a spring-loaded 21-gauge, 23-gauge, 26-gauge,  
15 28-gauge, 30-gauge and/or 33-gauge retractable finger lancet.

In another aspect, the invention is generally directed to a device for essentially pain-free receiving of blood or other substance from the skin of a subject, the device having an average pain indication of no more than 25% of the highest pain indication, as measured from the lowest pain indication to the highest pain indication according to at  
20 least one of the following pain scales: the Wong-Baker Faces Pain Scale, the Visual Analog Pain Scale, or the Numerical Pain Rating Scale.

Another aspect of the present invention is generally drawn to a device for receiving a substance from, and/or delivering a substance to, the skin of a subject. In accordance with one set of embodiments, the device includes a substance transfer  
25 component for insertion into the skin of a subject, having a pre-deployed position and a deployed position, and a deployment actuator, operably linkable to the substance transfer component. In some cases, the deployment actuator is switchable from a first stable configuration, through an unstable configuration, to a second stable configuration. In certain embodiments, in the first stable configuration, the substance transfer component  
30 are not contactable with the skin of the subject, and in the second stable configuration, the substance transfer components is insertable in the skin of the subject.

The device, in one set of embodiments, includes a substance transfer component for insertion into the skin of a subject, having a pre-deployed position and a deployed position, and a deployment actuator able to move the substance transfer component from the pre-deployed position to the deployed position in a period of time of less than 0.002  
5 seconds, and/or at a velocity of at least 6 meters/second when the substance transfer component first touches the skin during deployment.

In another set of embodiments, the device includes a substance transfer component for insertion into the skin of a subject, having a pre-deployed position and a deployed position, and a deployment actuator operably linkable to the substance transfer  
10 component. In some instances, the maximum distance between the deployment actuator and the skin of the subject is no more than 10 mm.

The device, in yet another set of embodiments, includes a substance transfer component for insertion into the skin of a subject, having a pre-deployed position and a deployed position, and a reversibly deformable structure, operably linkable to the  
15 substance transfer component. In some cases, the device may comprise at least one of a largest lateral dimension, when the device is positioned to receive or deliver the substance, parallel to the operating area, of no more than about 6 cm; or a largest vertical dimension, extending from the skin of the subject when the device is positioned to receive or deliver a substance, of no more than about 1.5 cm; or a mass of no more than  
20 about 25 grams, absent the substance.

In another set of embodiments, the device can include a substance transfer component for insertion into the skin of a subject, having a pre-deployed position and a deployed position, and a deployment actuator able to move the substance transfer component from the pre-deployed position to the deployed position at an average  
25 acceleration of at least 60,000 meters second squared.

The device, in yet another set of embodiments, includes a substance transfer component for insertion into the skin of a subject, having a pre-deployed position and a deployed position, and a deployment actuator able to move the substance transfer component from a fully pre-deployed position to a fully deployed position. In certain  
30 embodiments, the distance between the fully pre-deployed position to the fully deployed position is no more than 5,000 microns.

In accordance with still another set of embodiments, the device includes a substance transfer component with a plurality of insertion objects for insertion into the skin of a subject, having a pre-deployed position and a deployed position, each of the skin insertion objects protruding from a base and defining a length from the base, and in  
5 some embodiments, the plurality of skin insertion objects defines an average length of no more than 1,500 microns. In some cases the device includes a deployment actuator able to move the skin insertion objects from a fully pre-deployed position to a fully deployed position with a force sufficient to insert the plurality of skin insertion objects into or  
10 through the skin to an average depth of at least 60% the average length of the plurality of skin insertion objects.

In yet another set of embodiments, the device includes a substance transfer component for insertion into the skin of a subject, having a pre-deployed position and a deployed position, and a deployment actuator, operably linkable to the plurality of  
15 substance transfer component. In some cases, the deployment actuator may be switchable from a stored energy position to a deployed energy position. In some embodiments, the stored energy position is associated with the pre-deployed position of the substance transfer component, and the deployed energy position is associated with the deployed position of the substance transfer component.

Another aspect of the present invention is generally drawn to a device for  
20 delivering a substance to the skin of a subject. In accordance with one set of embodiments, the device includes a substance transfer component for insertion into the skin of a subject, having a pre-deployed position and a deployed position, and a deployment actuator, operably linkable to the substance transfer component. In some cases, the deployment actuator is switchable from a first stable configuration, through an  
25 unstable configuration, to a second stable configuration. In certain embodiments, in the first stable configuration, the substance transfer component are not contactable with the skin of the subject, and in the second stable configuration, the substance transfer components is insertable in the skin of the subject.

In some of the aforementioned aspects and embodiments, the substance transfer  
30 component is constructed and arranged to deliver, to the skin of the subject, a substance selected from the group consisting of a peptide, a protein, a carbohydrate, a nucleoprotein, a mucoprotein, a lipoprotein, a glycoprotein, a nucleic acid, a nucleotide,

nucleoside, a lipid, and a biologically active organic molecule. In addition, or alternatively, in some of the aforementioned aspects and embodiments, the substance transfer component is constructed and arranged to deliver, to the skin of the subject, an analgesic, including lidocaine, bupivacaine, and tetracaine.

5 In another aspect, the present invention is directed to a method of making one or more of the embodiments described herein, for example, devices for receiving blood from a subject. In another aspect, the present invention is directed to a method of using one or more of the embodiments described herein, for example, devices for receiving blood from a subject.

10 Other advantages and novel features of the present invention will become apparent from the following detailed description of various non-limiting embodiments of the invention when considered in conjunction with the accompanying figures. In cases where the present specification and a document incorporated by reference include conflicting and/or inconsistent disclosure, the present specification shall control. If two  
15 or more documents incorporated by reference include conflicting and/or inconsistent disclosure with respect to each other, then the document having the later effective date shall control.

### **BRIEF DESCRIPTION OF THE DRAWINGS**

20 Non-limiting embodiments of the present invention will be described by way of example with reference to the accompanying figures, which are schematic and are not intended to be drawn to scale. In the figures, each identical or nearly identical component illustrated is typically represented by a single numeral. For purposes of clarity, not every component is labeled in every figure, nor is every component of each  
25 embodiment of the invention shown where illustration is not necessary to allow those of ordinary skill in the art to understand the invention. In the figures:

Figs. 1A-1B illustrate devices according to certain embodiments of the invention;

Figs. 2A-2C illustrate devices according to various embodiments of the invention;

30 Fig. 2D illustrates a kit containing more than one device, in yet another embodiment of the invention;

Fig. 2E illustrates a device according to still another embodiment of the invention;

Fig. 3 illustrates a device in one embodiment of the invention, having a vacuum chamber;

5 Fig. 4 illustrates a device in another embodiment of the invention, having a vacuum chamber and a storage chamber;

Fig. 5 illustrates a device in yet another embodiment of the invention, having a flow controller;

10 Fig. 6 illustrates a device in yet another embodiment of the invention, having an exit port;

Fig. 7 illustrates a device according to another embodiment of the invention;

Fig. 8 illustrates a device containing a fluid reservoir, in another embodiment of the invention;

Fig. 9 illustrates an adaptor according to one embodiment of the invention;

15 Figs. 10A-10C illustrate a device in still another embodiment illustrating a deployment actuator;

Fig. 11 illustrates yet another embodiment of the invention in which a device is actuated by a deployment actuator;

20 Figs. 12A and 12B illustrate yet another embodiment of the invention, in which a device is actuated by a deployment actuator, at different stages of operation of the device;

Fig. 13 illustrates pain data quantified using the Wong-Baker FACES Pain Scale for certain devices, in accordance with another embodiment of the invention;

25 Figs. 14A-14C illustrate various devices according to certain embodiments of the invention; and

Figs. 15A-15C illustrate various devices according to various embodiments of the invention.

### DETAILED DESCRIPTION

30 The present invention generally relates to systems and methods for receiving a substance from a subject, e.g. received from the skin and/or from beneath the skin of the subject, and/or for delivering a substance to a subject, e.g. delivering a substance to the skin and/or to a location beneath the skin of a subject. Throughout the application, the

phrase “from the skin” is used to mean from the top or outer surface of the skin, from within the skin, and/or from beneath the skin. Likewise, “to the skin” is used to mean to the top or outer surface of the skin, to within the skin, and/or to beneath the skin. In one aspect, blood (or other bodily fluids) may be received from the subject with relatively  
5 little pain. In some embodiments, by using quick and/or high velocity, and/or high force and/or pressure application of a substance transfer component to the skin, blood may be received from the skin with surprisingly little pain. In other embodiments, the sensation of the device may be at least partially obscured. For example, the obscuration may be by time, and/or by sensory obscuration (e.g., by providing tactile, olfactory, auditory, and/or  
10 visual sensations). The pain may be assessed, for example, using pain scales such as the Wong-Baker FACES Pain Scale. The device, in some cases, may be interfaced with external equipment to determine an analyte contained within a fluid contained within or collected by the device. For example, the device may be mounted on an external holder, the device may include a port for transporting fluid out of the device, the device may  
15 include a window for interrogating a fluid contained within the device, or the like.

The received fluid may be any suitable bodily fluid, such as interstitial fluid, other skin-associated material, mucosal material or fluid, whole blood, perspiration, saliva, plasma, tears, lymph, urine, plasma, or any other bodily fluid, or combinations thereof. Substances received from a subject can include solid or semi-solid material such  
20 as skin, cells, or any other substance from the subject. Substances that can be delivered to a subject in accordance with some embodiments of the invention include diagnostic substances, therapeutic substances such as drugs, and the like. Various embodiments of the invention are described below in the context of delivering or receiving a fluid, such as blood, from or through the skin. It is to be understood that in all embodiments herein,  
25 regardless of the specific exemplary language used (e.g., receiving blood), the devices and methods of other embodiments of the invention can be used for receiving any substance from the skin and/or from beneath the skin of the subject, and/or for delivering any substance to the subject, e.g. to the skin and/or a location beneath the skin of the subject.

30 In certain aspects, bodily fluids such as blood may be received from a subject with relatively little pain. For example, as is discussed in detail below, in one set of embodiments, a deployment actuator is used to deliver a substance transfer component to



the skin (or a portion thereof, such as for example, one or more microneedles). As discussed in detail below, quick and/or high velocity, and/or high force and/or pressure application of a substance transfer component to the skin, e.g., using deployment actuators, may in certain embodiments result in lower pain or painless deployment.

5           The degree of pain produced by a device or application can be quantified using analytical techniques known to those of ordinary skill in the art, such as the Wong-Baker “FACES” pain scale, the Brief Pain Inventory (BPI), the Visual Analog Pain Scale, the Numerical Pain Rating Scale, or the McGill Pain Index. Other scales can also be used. Typically, pain scales are based on self-reporting, behavioral observation, physiological  
10 data, or the like. In some embodiments, a subject to which a device or method is applied may self-report, on a suitable scale, the degree of pain that the subject experiences when the device is applied.

For example, the Wong-Baker pain scale includes 6 faces rated between 0 and 10, or between 0% and 100%: 0 is “no hurt,” 2 or 20% is “hurts little bit,” 4 or 40% is  
15 “hurts little more,” 6 or 60% is “hurts even more,” 8 or 80% is “hurts whole lot,” and 10 or 100% is “hurts worst.” Scores of less than 2 are generally considered to be not painful. In one embodiment, a subject may be exposed to a device or other application, and the subject subsequently asked to rate the experience, using a suitable technique. For example, in the Wong-Baker “FACES” pain scale, various faces (e.g., 6 faces) which  
20 vary in expression from smiling to crying are presented to a subject, and the subject is asked to choose the face that best describes the experience. However, the faces may be quantified (e.g., the first face is rated 0, the second face is rated 2, the third face is rated 4, etc.), such that the experience of the subject may be determined quantitatively. As a specific example, for a given device or application, a population of subjects may give  
25 ratings such as 0, 0, 2, 0, 4, 2, 0, 4, etc., and such scores may be statistically analyzed, e.g., to determine means or standard deviations for the device.

Although pain has a subjective component and different subjects will have different responses to a given application, by applying the device to a sufficiently large population of subjects, e.g., subjects with no pre-existing medical conditions that could  
30 alter the reporting of pain (i.e., increased or decreased sensitivity), the degree of pain of an application may be sufficiently quantified, e.g., for comparison purposes. For example, a device or application may be applied to a population of at least 10 subjects, at

least 25 subjects, at least 35 subjects, at least 50 subjects, at least 75 subjects, or at least 100 subjects, and each of the subjects' scores averaged to produce an overall scale value for the device or application.

Surprisingly, various embodiments discussed herein result in the receiving of  
5 blood from a subject with very low pain scale values, e.g., as quantified using the Wong-Baker pain scale or other suitable techniques of measurement, as compared to prior art blood withdrawing devices such as needles or lancets, and in some cases, while large amounts of blood are received from the skin. In one set of embodiments, at least about  
10 10 microliters, at least about 30 microliters, at least about 50 microliters, at least about 75 microliters, at least about 100 microliters, at least about 150 microliters, at least about 200 microliters, or at least about 500 microliters may be received from a subject relatively pain-free. For example, the average Wong-Baker pain scale value after such relatively pain-free blood receipt, may be no more than 3, 2, 1, or 0.5.

In one set of embodiments, the device or application a subject is exposed to may  
15 have a value that is no more than the 25<sup>th</sup> percentile (25%) as measured from the lowest pain indication to the highest pain indication. For example, with respect to a pain scale that varies from 0 to 10, with 10 being the most pain, the average pain felt by a subject exposed to a device or application, over a suitable population of subjects (e.g., at least 10 subjects) may be no more than 2.5. In another set of embodiments, the device or  
20 application a subject is exposed to may have a value that is no more than the 10<sup>th</sup> percentile (10%) as measured from the lowest pain indication to the highest pain indication.

In another set of embodiments, the pain felt by a subject exposed to a device or technique of the invention is significantly less than the pain experienced in standard  
25 blood sampling from the subject using a standard spring-loaded retractable finger lancet. In particular, in one embodiment, the pain is significantly less than that experienced in a standard draw using a standard spring-loaded 21 gauge retractable finger lancet. In another embodiment, the pain is significantly less than that experienced using a standard spring-loaded 23 gauge retractable finger lancet. In other embodiments, the pain is  
30 significantly less than that experienced using a standard 25, 26, 28, 30, or 33 gauge standard spring-loaded retractable finger lancet. Those of ordinary skill in the art are familiar with standard spring-loaded finger lancets, which are widely commercially

available from a variety of sources for obtaining small volumes of blood for diabetic-related testing and many other uses. “Significantly less” pain, in this context, would be well understood by those of ordinary skill in the art. In one embodiment, significantly less pain means a clearly noticeable change in pain level by a subject. Different

5 individuals have different responses or tolerances to pain and, accordingly, in another embodiment, significantly less pain means that, on average, among 10 subjects tested both with the device of the invention and with a comparative standard spring-loaded finger lancet, more than 5 will indicate that they experienced significantly less pain with the device of the invention. In another set of embodiments, significantly less pain means

10 that a subject (or the average response of 10 subjects), will indicate pain experienced with a standard spring-loaded finger lancet (according to the various gauges described herein, in various embodiments) at least 5% higher than that experienced by the device of the present invention, as measured along the pain indication scale according to at least one of the pain scales described herein (the Wong-Baker Faces Pain Scale, the Visual

15 Analog Pain Scale, or the Numerical Pain Rating Scale). 5% higher, in this context, means that the pain indicated by the subjects (or group of subjects on average) is 5% higher on the scale than the pain indicated by use of the present invention, as measured against a 100% maximum defined by the entire range between lowest pain indication on the scale to the highest pain indication on the scale evenly spread over all possible pain

20 indications of the entire scale. In another set of embodiments, the subject experiences pain, using a standard spring-loaded retractable finger lancet, at least 10%, 15%, 20%, or 25% higher than that of the device of the invention as measured according to one of these pain scales. In another set of embodiments, the higher pain indication experienced by the subject through use of the finger lancet is at least 5%, 10%, 15%, 20%, or 25%

25 higher than that experienced according to all of the pain scales indicated (Wong-Baker, Visual Analog, Numerical Pain Rating Scale). It is to be noted that wherever “subject” is used herein, in another set of embodiments the subject is replaced by the average response of 10 subjects or another number of subjects described elsewhere herein. For example, in one set of embodiments, the average pain reported by 10 subjects using a

30 standard 25-gauge spring-loaded retractable finger lancet will be at least 10% higher, according to one of the pain scales indicated herein (or all pain scales) than that of the device of the invention. In another embodiment, the average of 10 subjects will

experience at least 5%, 10%, 15%, 20%, or 25% greater pain using a standard 28-gauge spring-loaded retractable finger lancet than the device of the invention, or 26-gauge lancet. For example, the pain felt by a device of the present invention may have a pain scale value statistically significantly less than a 28-30 gauge lancet used to draw the same amount of blood or other fluid from the subject, e.g., at a statistical confidence level of at least about 90%, 95%, or 99%. Such determinations can be made, for example, by comparing mean and standard deviation values for the devices, and determining if they are statistically significant at such confidence levels, using statistical techniques known to those of ordinary skill in the art.

Such determinations may be made, for example, using pain scales such as the Wong-Baker "FACES" pain scale, the Brief Pain Inventory (BPI), the Visual Analog Pain Scale, the Numerical Pain Rating Scale, or the McGill Pain Index, under conditions in which the subjects are exposed to one or more devices (e.g., for comparison of the devices), and asked after suitable injection and/or receiving of blood or other bodily fluids (e.g., of the same volume of fluid), to rate the experience using such a pain scale. Appropriate controls or protocols may be used in some embodiments, for example, dummy devices in which no insertion or receiving occurs, single or double-blind studies, suitable randomization techniques (e.g., regarding the order various devices are presented to the subject, or the like). Although randomly chosen subjects may vary regarding their reporting and the perception of the amount of pain experienced by the subject, such differences may be mitigated, at least in part, by comparing relative values rather than absolute values for such devices.

As an illustrative non-limiting example, a first subject may rate a first device as a 4 and a second device as a 6 (on a scale of 0 to 10, such as in the Wong-Baker pain scale), and a second subject may rate a first device as a 0 and a second device as a 2, but in a population of such varying subjects, e.g., at least 10 or more, at least 30 or more, etc., the average score for the first device will nonetheless be lower than the average score for the second device, which allows the conclusion to be drawn that the first device is significantly less painful than the second device. Even if the subjects are not completely randomly chosen (e.g., all subjects are male), such differences may be compensated for, at least in part, due to the relative comparison of such tests (e.g., females may on average report higher or lower scores than males for a particular device,

but in both cases, the relative differences between the devices will still be preserved, and such relative differences can be determined at statistical confidence levels using techniques such as those discussed herein).

In certain embodiments, blood may be received relatively quickly, and relatively pain-free; for example, blood may be received from a subject at a rate of at least about 5 microliters per minute, 10 microliters per minute, at least about 20 microliters per minute, at least about 30 microliters per minute, at least about 50 microliters per minute, at least about 100 microliters per minute, at least about 300 microliters per minute, or at least about 500 microliters per minute.

In some embodiments, the substance transfer component may include one or more skin insertion objects, such as needles, microneedles, lancets, blades, knives, protrusions, or other suitable object. As used herein, a "skin insertion object," may be inserted into any organ, tissue or portion of a subject and is not restricted for use with only skin.

In one set of embodiments, needles or other skin insertion objects such as any of the ones described herein (including microneedles) may be used to cause release of blood from a subject in a relatively pain-free manner. The use of smaller needles or other objects may result in less pain, e.g., due to a smaller probability of reaching a nerve, and/or the psychological effect of using a smaller needle (e.g., one that is difficult to see without the aid of equipment), as opposed to a larger one. As mentioned, pain is in part psychological, and a subject seeing a needle perceived to be weak or small may be psychologically conditioned to believe that the needle would cause less pain.

In another set of embodiments, quick and/or high velocity, and/or high force and/or pressure application of skin insertion objects to the skin, such as microneedles, or other substance transfer components, may in certain embodiments result in lower pain or painless deployment. Without wishing to be bound by any theory, it is believed that higher velocities, forces, etc., may result in faster penetration of the objects into the skin, which results in less damage to the skin, and thus less pain. In addition, relatively rapid insertions may give a subject less sensation of pain, and/or less time to become apprehensive to the insertion, thereby resulting in lower perceived pain. Examples of devices able to deliver objects quickly and/or at high velocity, and/or with high force

and/or pressure are disclosed in detail herein, and include, but are not limited to, snap domes and other deployment actuators such as those described below.

In yet another set of embodiments, the pain experienced by a subject may be at least partially obscured, thereby reducing the perception of pain when skin insertion objects such as microneedles are inserted into the skin. For example, the obscuration may be by time, and/or by sensory obscuration (e.g., by providing tactile, olfactory, auditory, and/or visual sensations). It is believed, without wishing to be bound by any theory, that such obscurations may distract the subject from fluid delivery and/or receipt, which may accordingly cause the subject to feel less pain since the subject's attention is diverted.

In some cases, subjects may experience more pain if they believe something painful is about to occur. Accordingly, by obscuring the painful event in some fashion, a relatively painful event can be perceived to be less painful, e.g., if the subject's attention is diverted. Thus, the present invention provides, in some aspects, systems and methods for obscuring relatively painful experiences in connection with devices for delivering and/or receiving fluid from the skin of a subject. The obscuration may be by time (e.g., by allowing a certain or a random amount of time to elapse, wherein the subject's attention may be diverted), and/or by sensory obscuration (e.g., by providing tactile, olfactory, auditory, and/or visual sensations which at least partially obscures sensations caused by delivering and/or receiving fluid from the skin, and/or by covering the location where delivery and/or receiving of fluid occurs).

One set of embodiments of the invention is generally directed to a device where the activation of a device for delivering and/or receiving fluid from the skin of a subject, and the actual act of delivering and/or receiving fluid, are not essentially simultaneous. Examples of such devices are also disclosed in U.S. Provisional Patent Application Serial No. 61/256,880, filed October 30, 2009, entitled "Systems and Methods for Altering or Masking Perception of Treatment of a Subject," by Chickering, *et al.*, incorporated herein by reference in its entirety. Thus, time may elapse between activation and the actual delivery and/or receipt, wherein the subject's attention may be diverted elsewhere, e.g., simply by everyday occurrences, or due to boredom in the interim. The subject may, in some cases, be free to move on to do other things, e.g., while wearing the device, for example, if the device is wearable or portable. For

example, the time period can be at least about 30 seconds, at least about 45 seconds, at least about 1 minute, at least about 2 minutes, at least 3 minutes, at least about 4 minutes, at least about 5 minutes, at least about 10 minutes, at least about 15 minutes, at least about 30 minutes, at least about 45 minutes, at least about 1 hour, etc. In some cases, the time period can be randomly determined, e.g., by the device, further decreasing the subject's expectation of the actual fluid delivery and/or receipt. In some cases, the time may be sufficient that a subject may have forgotten about the device. Thus, due to the passage of time between the time the device is initially activated, and the time the device begins to deliver and/or receive fluid, the subject may no longer be expecting or sure of the delivery and/or receiving of fluid, and thus, the subject may perceive less associated pain. In another set of embodiments, the location in which fluid is delivered and/or received may be obscured from the subject. Obscuring the location, in some subjects, may reduce the perception of pain, as the subject may not see anything going on that would lead to a psychological impression of pain (e.g., the appearance of blood, a needle being inserted into the skin, etc.). The obscuration of the location of fluid delivery and/or receipt may be by any suitable technique. For example, at least a portion of the device may be composed of opaque materials, or the device may include one or more covers that cover the location of delivery and/or receiving of fluid from the skin. The covers may be rigid or solid, and may be formed out of any suitable material, e.g., an opaque material, and/or dyed or painted to be opaque, etc.

In some embodiments, the device may produce sensory obscuration (e.g., tactile, olfactory, auditory, and/or visual sensations) which can at least partially obscure any sensations caused by delivering and/or receiving fluid from the skin. In certain cases, one or more of these obscuration techniques may be used, e.g., in conjunction with each other, and/or in conjunction with other techniques described herein, e.g., timing.

For example, in one set of embodiments, the device may include a speaker or otherwise be able to produce noise or music, e.g., that is able to distract the subject. The music may be, for instance, fast tempo music, techno, or punk rock (e.g., which may be relatively jarring to the ear, thereby getting the attention of the subject), or slow or ambient music (e.g., which may cause the subject to become more calm and less fearful of any sensations caused by fluid receipt and/or delivery). In some cases, the device may produce noise, for example, artificially-created noise, to distract the subject, for example,

ticking, humming, or buzzing noises. In one set of embodiments, the music may be selectable, e.g., by the subject, and in some cases, the music may be uploaded into the device from another source, e.g., of the subject's choosing. The noise may be "artificial," e.g., created by a speaker or a mechanical device, as opposed to noise that is inherently created by the device when a fluid transported is used to deliver and/or receive fluid, for example, by a change in pressure caused by the device (e.g., vacuum), by movement of fluid and/or a substance transfer component in the device, etc.

In another set of embodiments, the device may include systems for producing tactile sensations to at least partially obscure any sensations caused by delivering and/or receiving fluid from the skin. For instance, the device may produce vibration, heat, cooling, etc. to the skin to distract the subject. For example, in one embodiment, the device may buzz or vibrate, similar to a cellphone buzzer. In another embodiment, the device may include a heater or a cooler to cause a temperature change, thereby distracting the subject. In one set of embodiments, the device may produce mechanical sensations for obscuring sensations caused by delivering and/or receiving fluid from the skin. For example, the device may include mechanical parts that create the feeling of a "click" when a button is pushed on the device; thus, when the button is pushed, the subject feels various mechanical movements within the device, perceived as a firm "clicking" sensation, wherein the clicking sensation is able to at least partially obscure the sensation of the device in operation, e.g., inserting a needle, applying a chemical to the skin, delivering or receiving fluid, etc.

The device, in yet another set of embodiments, may include systems and methods for creating visual patterns or displays to distract the subject. For example, the device may have one or more lights thereon (e.g., LEDs, strobe lights, laser lights, etc.), which can be turned on or off by the device. The lights may blink in one or more patterns, or flash randomly, etc., which may be used to distract the subject. As another example, the device may include a display which can display distracting information, e.g., patterns, a movie, a TV show, a podcast, random static, or the like. A subject may be able to watch the display, thereby not focusing on fluid delivery and/or receipt, and accordingly decreasing the perceived sensation of pain. Combinations of these are also possible, e.g., the device may be used, in part, to display a movie or a TV show, including both a picture on a display and sound via a speaker.



In still another set of embodiments, the device may create a distraction by emitting one or more smells, e.g., using volatile chemicals. The chemicals, in certain embodiments, may be stored on the device (for example, in one or more chambers located on the device), and released when needed (e.g., upon or after activation of  
5 device). The chemicals may be used to create a pleasant odor (e.g., a flower smell), or an unpleasant odor (e.g., H<sub>2</sub>S), depending on the application and the potential for distracting the subject. In some cases, the compound is volatile to facilitate odor detection by the subject. In some cases, the particular chemical used by the device may vary by subject, and in certain instances, the subject may be able to choose the particular chemical used  
10 by a particular device, e.g., to be particularly effective to the subject.

As a non-limiting example, Fig. 14A shows one embodiment of a device 100. In this figure, device 100 includes a substance transfer component, which may include one or more skin insertion objects 102, e.g., needles, microneedles, etc., as discussed herein. The substance transfer component may also include a recess 101 and any other fluid  
15 transporter or flow activator. Recess 101 may be connected to vacuum source 103 and sensor 104 (e.g., an assay test strip, or other sensor as discussed herein) by channel 105. Vacuum source 103 may be used to draw the skin into recess 101 and/or to receive fluid from the skin, e.g., blood, interstitial fluid, or the like. In this example, following interaction of the received bodily fluid with sensor 104, a detector 106 may be used to  
20 determine any results. The device in Fig. 14A also may include electronics 107 for controlling the device, e.g., a power supply, processor, memory component, or other suitable electronics components. For example, in some embodiments, data may be uploaded into the memory using a port 108 (i.e., a mini USB port, a wireless transceiver, etc.) or from a card inserted into slot 109 (i.e., a microSD card or other suitable memory  
25 card, or the like). As another non-limiting example, the memory may be preconfigured with data.

In this example, device 100 may contain a sound generator 110, which may be, for example, a speaker, vibration apparatus, a mechanical relay, or any other suitable apparatus capable of generated a desired sound, e.g., music, a ticking sound, a humming  
30 sound, a buzzing sound, etc. as discussed above. In some cases, the sound may be selected by a user, e.g., as previously discussed. Sound generator 110 may be in contact with electronics 107 for controlling the sound generator, and the sound may be used for

any suitable purpose. For example, instructions on how to use device 100 may be broadcast via sound generator 110, or sound generator 110 may be used to indicate the status of the device (for example, by playing one sound while an assay is being performed and/or fluid is being received or delivered, and/or by playing a sound when an operation is complete). In some cases, as previously discussed, sound may be produced to distract the subject. For example, sound generator 110 may be used to produce soothing noise, distracting noise, loud noises, unexpected noises, music, etc., depending on the application. In some cases the choice of sound may be selected by the subject, and/or by another person.

In some embodiments, the device may include a display 111. The display may be used to, for example, display assay results and/or may also be used to display picture or video media. The display may be present instead of, or in conjunction with, sound generator 110 (in the specific example shown in Fig. 14A, device 100 contains both a display 111 and a sound generator 110). Thus, for example, the display may be used for providing instructions for using the device, for providing the status of the device (e.g., whether the device is ready, in use, being “warmed up,” or has been used, how much fluid has been delivered and/or received, instructions for how to dispose the device, etc.). In some cases, as previously discussed, the display may be used to distract the subject. For example, the display may display a series of lights a pattern, play a movie or a TV show (e.g., in conjunction with a sound generator), provide a game to the subject, or the like.

A similar device is illustrated in Fig. 14B. In this figure, device 100 includes temperature apparatus 118, which may be, for example, a heating device (e.g., a resistive heater, a heater caused by the mixing of chemicals, such as a supersaturated solution of sodium acetate, iron filings with oxygen, a thermite reaction, or the like), a cooling device (e.g., a Peltier cooler, a cooler caused by the mixing of two chemicals, such as water and urea or ammonium nitrate, a fan, a refrigeration unit, etc.), or a vibrating device (e.g., a mechanical motor or vibrator). As shown in Fig. 14B, temperature apparatus 118 may be positioned to be in contact with the skin when device 100 is positioned on the skin of the subject.

Yet another device is illustrated in Fig. 14C. In this figure, device 100 includes one or more light sources 132. Light sources 132 may be, for example, LEDs,

fluorescent lights, strobe lights, lasers, etc. In this example, light sources 132 may be used to create visual patterns or displays to distract the subject. For instance, the light sources may be activated in a pattern to distract the subject from the effects of substance transfer component as the substance transfer component is used to deliver and/or receive fluid from the skin of the subject. As an example, light sources may be displayed or flashed in various patterns, for example, to display a pleasing pattern, an image, a logo, or a random pattern. In some cases, light sources 132 may be controlled using electronics 107 contained within device 100. In some cases, light sources 132 may be used to display information to the subject as well, in conjunction or instead of being used to distract the subject. For instance, a light source may be used to indicate adequate power in the device, whether the device is ready to be used, is in use, or has already been used, the time before an operation is completed, etc.

In yet another set of embodiments, pain resulting from delivering and/or receiving fluid from the skin of a subject may be obscured by using a substance transfer component to apply an analgesic or other agent to the skin that alters or inhibits sensation. For example, an analgesic such as benzocaine, butamben, dibucaine, lidocaine, bupivacaine, tetracaine, oxybuprocaine, pramoxine, proparacaine, proxymetacaine, or tetracaine may be applied to the skin, prior to or during delivery and/or receipt of fluid, or another obscuring agent may be applied, e.g., an agent to cause a burning sensation, such as capsaicin or capsaicin-like molecules, for example, dihydrocapsaicin, nordihydrocapsaicin, homodihydrocapsaicin, homocapsaicin, or nonivamide.

The analgesic or other agent may be applied to the skin using any suitable technique, e.g., using the device, or separately. The analgesic or other agent may be applied to the skin automatically, or upon activation of the device as discussed herein. For example, the analgesic or other agent may be delivered to the skin by the substance transfer component (e.g., via a microfluidic channel from a chamber containing the fluid) prior to, or after, exposure of the skin to a skin insertion object (if used) as discussed herein. In some embodiments, the substance transfer component can supply analgesic or other agent to the skin via spraying, e.g., through a nozzle. In another embodiment, a sponge, gauze, swab, or other absorbent material may be applied to the skin (e.g., by the device) to apply the analgesic or other agent to the skin, e.g., to blood or other bodily

fluids present on the skin. In some cases, a skin insertion object of the substance transfer component may pass through the absorbent material. For example, upon application of the device to the skin, a portion of the device (e.g., a cover) may be moved, thereby exposing the skin to absorbent material contained within the device that contains the analgesic or other agent to be applied to the skin. A needle or other skin insertion object may pass through the absorbent material, carrying an analgesic, anesthetic or other substance to the skin. In some cases, the substance transfer component may include an applicator, such as a brush or a sponge, may be moved on the surface of the skin to apply the analgesic or other agent the skin. For example, the device may move an applicator across the surface of the skin. In yet other embodiments, a substance may be carried by a skin insertion object of the substance transfer component such as a needle or set of needles, that are inserted into a subject. The analgesic or other agent may be coated onto the skin insertion objects, such as by dip or spray coating or other suitable technique. Thus, the analgesic or other agent may be delivered to or beneath the skin by the substance dissolving or otherwise detaching from the substance transfer component at or in the skin or other subject site. Alternately, the analgesic or other agent may be delivered after a substance transfer component penetrates the subject, e.g., in a way similar to a hypodermic needle. For example, a skin insertion object of the substance transfer component may be inserted into the skin, and an analgesic or other agent may be pumped or pushed through a hole, groove or other channel of the skin insertion object (e.g., by a high pressure gas).

In one aspect, the present invention is generally directed to devices and methods for receiving or extracting blood or other bodily fluids from a subject, e.g., from the skin and/or from beneath the skin, using devices having a substance transfer component (which may include, for example, one or more microneedles and/or other skin insertion objects). The device may also contain, in some embodiments, a storage chamber having an internal pressure less than atmospheric pressure prior to receiving blood or other bodily fluids. In some cases, the device may pierce the skin of the subject, and fluid can then be delivered and/or received from the subject. The subject is usually human, although non-human subjects may be used in certain instances, for instance, other mammals such as a dog, a cat, a horse, a rabbit, a cow, a pig, a sheep, a goat, a rat (e.g.,

*Rattus Norvegicus*), a mouse (e.g., *Mus musculus*), a guinea pig, a hamster, a primate (e.g., a monkey, a chimpanzee, a baboon, an ape, a gorilla, etc.), or the like.

In some cases, the device can be applied to the skin, and activated to receive fluid from the subject. The device, or a portion thereof, may then be processed to determine  
5 the fluid and/or an analyte within the fluid, alone or with an external apparatus. For example, fluid may be received from the device, and/or the device may contain sensors or agents able to determine the fluid and/or an analyte suspected of being contained in the fluid.

The invention, in one set of embodiments, involves the determination of a  
10 condition of a subject. Bodily fluids and/or other material associated with the skin may be analyzed, for instance, as an indication of a past, present and/or future condition of the subject, or to determine conditions that are external to the subject. Determination may occur, for instance, visually, tactilely, by odor, via instrumentation, etc. In one aspect, accordingly, the present invention is generally directed to various devices for delivering  
15 and/or receiving blood, or other bodily fluids, from the skin and/or from beneath the skin of a subject. Accordingly, in the description that follows, the discussion of blood is by way of example only, and in other embodiments, other fluids may be received from the skin in addition to and/or instead of blood.

In one set of embodiments, the device includes a substance transfer component  
20 able to deliver to or receive fluid from the subject. As used herein, "substance transfer component" is any component or combination of components that facilitates movement of a substance or a fluid from one portion of the device to another, and/or from the device to the subject or vice versa. The substance transfer component may include an opening of any size and/or geometry that is constructed to receive fluid into the device.  
25 For example, an opening of a substance transfer component may lie in a two-dimensional plane or the opening may include a three-dimensional cavity, hole, groove, slit, etc. In some embodiments, the substance transfer component may also include one or more microneedles or other skin insertion objects, arranged to cause fluid to be released from the subject, e.g., by piercing the skin of a subject. In some embodiments, if fluid may  
30 partially or fully fill an enclosure surrounding a skin insertion object or other object, then the enclosure can define at least part of a substance transfer component. A substance transfer component may include any other suitable fluid transporter or flow activator.

Other components including partially or fully enclosed channels, microfluidic channels, tubes, wicking members, vacuum containers, etc. can be, or be a part of, a substance transfer component.

If needles or microneedles are used, they may be solid or hollow, i.e., blood or  
5 other fluid may travel in and/or around the needles or microneedles into or from the device. In some cases, the needles or microneedles may also be removed from the subject, e.g., after insertion into the skin, for example, to increase the flow of blood or other fluids from the subject. In one set of embodiments, the substance transfer component includes solid needles that are removed from the skin and a cup or channel to  
10 direct the flow of blood or other bodily fluids.

It should be noted that a skin insertion object or other flow activator need not be included with all embodiments as the device may not necessarily employ a mechanism for causing fluid release from the subject. For instance, the device may receive fluid that has already been released due to another cause, such as a cut or an abrasion, fluid release  
15 due to a separate and independent device, such as a separate lancet, an open fluid access such as during a surgical operation, and so on. Additionally, fluid may be introduced into the device via urination, spitting, pouring fluid into the device, etc. If included, a skin insertion object or other substance transfer component may physically penetrate, pierce, and/or or abrade, chemically peel, corrode and/or irritate, release and/or produce  
20 electromagnetic, acoustic or other waves, other otherwise operate to cause fluid release from a subject. The substance transfer component may include a moveable mechanism, e.g., to move a needle, or may not require movement to function. For example, the substance transfer component may include a jet injector or a “hypospray” that delivers fluid under pressure to a subject, a pneumatic system that delivers and/or receives fluid, a  
25 hygroscopic agent that adsorbs or absorbs fluid, a reverse iontophoresis system, a transducer that emits ultrasonic waves, or thermal, radiofrequency and/or laser energy, and so on, any of which need not necessarily require movement of an element to cause fluid release from a subject.

In some aspects, the device may include a support structure, such as a housing.  
30 The housing may be used, as discussed herein, for applying the substance transfer component to the surface of the skin of the subject, e.g., so that fluid may be delivered and/or received from the skin of the subject. In some cases, the housing may immobilize

the substance transfer component such that the substance transfer component cannot move relative to the housing; in other cases, however, the substance transfer component, or a portion thereof, may be able to move relative to the housing. In one embodiment, as a non-limiting example, the substance transfer component is immobilized relative to the housing, and the deployment actuator is positioned within the device such that application of the device to the skin causes at least a portion of the substance transfer component to pierce the skin of the subject. In some cases, as previously discussed, the housing encloses a deployment actuator.

In some embodiments, the deployment actuator, or a portion of the deployment actuator, may move from a first position to a second position. For example, the first position may be one where the deployment actuator has attached thereto a substance transfer component that is not in contact with the skin (e.g., a skin insertion object of the substance transfer component may be contained within a recess of the substance transfer component), while the second position of the deployment actuator may be one where the substance transfer component does contact the skin, e.g., to pierce the skin. The deployment actuator may be moved using any suitable technique, e.g., manually, mechanically, electromagnetically, using a servo mechanism, or the like. In one set of embodiments, for example, the deployment actuator may be moved from a first position to a second position by pushing a button on the device, which causes the deployment actuator to move (either directly, or through a mechanism linking the button with the deployment actuator). Other mechanisms (e.g., dials, levers, sliders, etc., as discussed herein) may be used in conjunction of or instead of a button. In another set of embodiments, the deployment actuator may be moved from a first position to a second position automatically, for example, upon activation by a computer, upon remote activation, after a period of time has elapsed, or the like. For example, in one embodiment, a servo connected to the deployment actuator is activated electronically, moving the deployment actuator from the first position to the second position. In some cases, the deployment actuator may include a triggering mechanism that initiates deployment.

In some cases, the deployment actuator and/or the substance transfer component may also be moved from the second position to the first position (or some other position). For example, after fluid has been delivered and/or received from the skin, e.g.,

using a substance transfer component, the deployment actuator may be moved, which may move the substance transfer component away from contact with the skin. The deployment actuator may be moved from the second position to the first position using any suitable technique, including those described above, and the technique for moving  
5 the deployment actuator from the second position to the first position may be the same or different as that moving the deployment actuator from the first position to the second position.

In some cases, the device may be able to draw skin towards the substance transfer component. For example, in one set of embodiments, the device may include a vacuum  
10 interface or region. The interface or region may be connected with a vacuum source (external and/or internal to the device), and when a vacuum is applied, skin may be drawn towards the device, e.g., for contact with a substance transfer component, such as one or more needles or microneedles.

In one set of embodiments, the device includes a deployment actuator able to  
15 drive a substance transfer component into the skin, e.g., so that the device can receive a fluid from the skin of a subject, and/or so that the substance transfer component can deliver a substance to a subject, e.g. deliver a substance to the skin and/or to a location beneath the skin of a subject. The deployment actuator may be a structure that can be deformed using unaided force (e.g., by a human pushing the structure), or other forces  
20 (e.g., electrically-applied forces, mechanical interactions or the like), but is able to restore its original shape after the force is removed or at least partially reduced. For example, the structure may restore its original shape spontaneously, or some action (e.g., heating) may be needed to restore the structure to its original shape. In one set of  
25 embodiments, the deployment actuator may include a flexible concave member or a reversibly deformable structure that is moveable between a first configuration and a second configuration. The deployment actuator may be formed out a suitable elastic material, in some cases. For instance, the structure may be formed from a plastic, a polymer, a metal, etc. In one set of embodiments, the structure may have a concave or  
30 convex shape. For instance, the edges of the structure may be put under compressive stress such that the structure “bows” out to form a concave or convex shape. A person pushing against the concave or convex shape may deform the structure, but after the person stops pushing on the structure, the structure may be able to return to its original



concave or convex shape, e.g., spontaneously or with the aid of other forces as previously discussed. In some cases, the device may be bistable, i.e., having two different positions in which the device is stable.

An example of a deployment actuator is now illustrated with respect to Fig. 10.

5 In Fig. 10A, structure 700 has a generally concave shape, and is positioned on the surface of skin 710. Structure 700 also includes a substance transfer component 720 for insertion into the skin. In Fig. 10B, a person (indicated by finger 705) pushes onto structure 700, deforming at least a portion of the structure and thereby forcing a substance transfer component 720 into at least a portion of the skin. In Fig. 10C, after  
10 the person releases structure 700, the structure is allowed to return to its original position, e.g., spontaneously, lifting substance transfer component 720 out of the skin. In some cases, e.g., if the substance transfer component includes needles or other skin insertion objects that are sufficiently large or long, blood or other fluids 750 may come out of the skin through the holes created by the needles, and optionally the fluid may be  
15 collected by the device for later storage and/or use, as discussed herein.

As another example, referring now to Fig. 11, a device 1100 is illustrated schematically in which a substance transfer component is driven by a deployment actuator. In Fig. 11, device 1100 includes a housing 1102 defining a plurality of chambers and channels. In other embodiments (not shown) a plurality of components  
20 that can be separable from and attachable to each other (e.g., modular components) can together define the device and together define a series of channels and compartments necessary for device function. See, e.g., U.S. Patent Application Serial No. 12/716,233, filed March 2, 2010, entitled "Systems and Methods for Creating and Using Suction Blisters or Other Pooled Regions of Fluid within the Skin," by Levinson, *et al.*; U.S.  
25 Patent Application Serial No. 12/716,226, filed March 2, 2010, entitled "Techniques and Devices Associated with Blood Sampling," by Levinson, *et al.*; or U.S. Patent Application Serial No. 12/716,229, filed March 2, 2010, entitled "Devices and Techniques Associated with Diagnostics, Therapies, and Other Applications, Including Skin-Associated Applications," by Bernstein, *et al.*, each incorporated herein by  
30 reference.

In the specific device illustrated, device 1100 includes a surface 1104 for positioning the device proximate the skin of a subject during use. Where desired in

certain embodiments, the device can include an adhesive layer 1106 where the adhesive is selected to be suitable for retaining the device in a relatively fixed position relative to the skin during use, but may allow for relatively easy removal of the device from the skin following use. Specific non-limiting examples of adhesives are discussed below. The adhesive also can be selected to assist in maintaining a vacuum within portions of the device proximate the skin as will be understood.

In Fig. 11, device 1100 includes a substance transfer component 1108. The substance transfer component may be or include, for example, a skin insertion object or other suitable object as discussed herein. Specific non-limiting examples include needles or microneedles, e.g., as shown in Fig. 11. The substance transfer component can be or include, as described elsewhere herein and in other documents incorporated herein by reference, any of a variety of components able to receive a substance from the skin and/or from beneath the skin of a subject, and or deliver a substance to the skin and/or to a location beneath the skin of the subject. For example, the substance transfer component may include one or more needles and/or microneedles, a hygroscopic agent, a cutter or other piercing element, an electrically-assisted system, or the like. In the specific device illustrated, substance transfer component 1108 includes an array of skin insertion objects such as solid or hollow microneedles. In one set of embodiments, substance transfer component 1108 is selected to have a particular size and profile for a particular use. For example, the substance transfer component may include an array of skin insertion objects which, in the device illustrated, emanate from a base 1110 which will be described further below.

In certain embodiments, a plurality of skin insertion objects of the substance transfer component 1108 and are relatively small, and are relatively completely driven into the skin. The skin insertion objects may be positioned to address the skin of the subject, each protruding from a base and defining a length from the base, and are able to be inserted into or through the skin to a depth essentially equal to their length but are prevented, by the base, from inserting at a depth greater than their length. In some embodiments, the plurality of skin insertion objects have an average length (measured from the base) of no more than about 1,000 microns or more than about 2,000 microns, although lengths can differ between individual skin insertion objects. In one set of embodiments, the skin insertion objects are of relatively uniform length, together

defining an average length and each differing from the average length by no more than about 50%, about 40%, about 30%, about 10%, or about 5%. The average length of the skin insertion objects, in other embodiments, are no more than about 1,500 microns, no more than about 1,000 microns, no more than about 900 microns, no more than about 800 microns, no more than about 750 microns, no more than about 600 microns, no more than about 500 microns, no more than about 400 microns, or no more than about 350 microns. In some embodiments, a deployment actuator as discussed herein is provided that is able to move the skin insertion objects from a fully pre-deployed position to a fully deployed position with a force sufficient to insert the plurality of skin insertion object into or through the skin to an average insertion depth of at least about 50% the average length of the plurality of skin insertion objects. In other embodiments, the deployment actuator is able to insert the plurality of skin insertion objects to an average insertion depth of at least about 55%, at least about 60%, at least about 65%, at least about 70%, at least about 75%, at least about 80%, at least about 85%, at least about 90%, at least about 92%, about 94%, about 96%, or about 98% of the average length of the plurality of skin insertion objects.

In the device illustrated, the skin insertion objects of the substance transfer component 1108 are mounted on a flexible structure 1112 which, as illustrated, is maintained relatively rigidly through various aspects of the device but which mounts substance transfer component 1108 flexibly for up/down movement relative to the skin. Flexible structure 1112 can be a membrane, a single or multi-layer structure selected from various polymers or the like to provide sufficient properties such as any combination of flexibility, elasticity, gas permeability or impermeability, fluid permeability or impermeability, or the like for desired operation. Portions of flexible structure 1112, skin insertion objects 1108, and other interior walls of the device define a region 1114 which allows for movement of skin insertion objects 1108 relative to the skin for delivery of a substance to and/or receiving of a substance from the skin or beneath the skin, and, where a substance is received from the skin or from beneath the skin, region 1114 can serve as a reservoir for introduction of the substance into the device. Where a vacuum is used to receive a substance from the subject (as in the embodiment illustrated in Fig. 11), region 1114, when positioned against the skin, can

expose vacuum to that portion of the skin proximate surface 1104 of the device and abutting the chamber.

Device 1100 also includes a transfer component actuator 1116 which, as illustrated, includes a proximate portion 1118 which can be addressed by a user of the device (who may be the same or different from the subject the device is administered to) and a distal portion 1120 for addressing skin insertion objects 1108 via flexible structure 1112. Proximal portion 1118 and distal portion 1120 are, in the device illustrated, opposite ends of a single component but, as would be understood by those of ordinary skill in the art, the actuator can include a plurality of individual components operably linked in any way necessary to perform actuation as will be described.

As will be understood, Fig. 11 is a cross-section of a device illustrating various components and channels within the device. As will also be understood by those of ordinary skill in the art, different arrangements of devices and channels are contemplated herein so long as the purpose of the device described herein is met. In this figure, device actuator 1116 is directly connected to or otherwise operably linked to a deployment actuator 1122 which, in the device illustrated, is in the form of a “snap dome,” the function and use of which will be described below. The snap dome in this figure has an approximately circular profile. The structure may define an interior and a periphery which, if not circular, may include a plurality of tabs, protrusions, or the like sufficient for support of structure 1122 within the device. As illustrated, a plurality of tabs (or the essentially circular perimeter of) the device are supported within holders 1124, and the center, snap dome portion of the device is operably linked to device actuator 1116, such that movement of the central portion of snap dome 1122 and the periphery of the snap dome can be controlled independently of each other. Holders 1124 are directly connected to or otherwise operably linked to a retraction actuator 1126 which, in the device illustrated, can be a ring-shaped structure positioned under and supporting holders 1124. Holders 1124 can be individual holders and/or a ring-like structure surrounding the periphery of snap dome 1122. A series of one, two, or more support members (e.g., 1130) are positioned near the top of device 1100 and serve to define a series of channels for sample flow, vacuum control, or the like as will be described.

Turning now to channels defined within the device, as described above, region 1114, when the device is positioned against skin, can serve to expose a portion of the

skin defined by the periphery of the region to a vacuum, to substance transfer component 1108 as it moves toward and/or away from the skin, and/or to transfer a substance from or to the subject. Region 1114 can house a substance for transfer to the subject, in the form of a pharmaceutical composition or the like, optionally loaded on skin insertion objects 1108. Where blood and/or interstitial fluid is drawn from a subject, region 1114 can serve to introduce the substance into the device from the subject.

A channel 1132 connects region 1114 to other portions of the device in this example. Channel 1132 can be used to deliver a substance to region 1114 for transfer to a subject, or for application of a vacuum to region 1114, and/or for receiving of a substance from a subject. The remainder of the description of device 1100 will be made within the context of receiving a substance such as blood and/or interstitial fluid from a subject, but it is to be understood that substances can also be delivered via various channels. Channel 1132 typically emanates in one direction from region 1114 although a plurality of channels can emanate from the region, arranged radially or otherwise relative to the center of the device. In device 1100, channel 1132 first passes laterally from the center of the device and then upwardly where, near the top of the device, it can, optionally, include one wall defining a window 1134 through which a user of the device can observe transfer of a substance, or through which analysis of a substance may occur. It can also itself define a reservoir, in whole or in part, or be connected to an internal or an external reservoir for maintaining, storing, and/or transferring a substance drawn from a subject. As shown here, it can be connected to a substance collection reservoir 1136 which, as illustrated, is a disc-shaped reservoir formed in the device housing and surrounding the center of the device including device actuator 1116 and related components.

Device 1100, illustrated as one example of devices provided by the invention, includes a vacuum chamber for applying a vacuum proximate the skin of a subject for receiving a substance from the skin. As illustrated, vacuum chamber 1138 is positioned in a central portion of the device surrounding device actuator 1116, although it can be provided anywhere in or proximate the device. The vacuum chamber can be evacuated to an appropriate level just prior to use, or the device can be pre-packaged under vacuum as described elsewhere herein. As illustrated, vacuum chamber 1138 is in fluid communication with substance collection reservoir 1136 but, in its initial state and prior

to use, a membrane or other component, such as support member 1128, separates channel 1132 connecting it to region 1102. In the device illustrated, a vacuum actuation component 1140 can be actuated to puncture the membrane or other component (e.g., 1128) and thereby connect vacuum chamber 1138 with channel 1132, at an appropriate  
5 time during use of the device. In other embodiments, device actuator 1116 and vacuum actuation component 1140 can be combined into a single button or operably linked so that only one operation is needed to actuate both the skin insertion objects and the vacuum.

Deployment actuator (or, as shown, a snap dome) 1122 can be provided in a  
10 variety of forms including a monostable or bistable configuration. In the embodiment illustrated, a bistable configuration is illustrated including first and second low energy or stable configurations separated by a relatively high energy or unstable configuration. As shown, the deployment actuator 1122 is shown in a “cocked” or pre-deployed position.

The deployment actuator may be formed from any suitable material, for example,  
15 a metal such as stainless steel (e.g., 301, 301LN, 304, 304L, 304LN, 304H, 305, 312, 321, 321H, 316, 316L, 316LN, 316Ti, 317L, 409, 410, 430, 440A, 440B, 440C, 440F, 904L), carbon steel, spring steel, spring brass, phosphor bronze, beryllium copper, titanium, titanium alloy steels, chrome vanadium, nickel alloy steels (e.g., Monel 400, Monel K 500, Inconel 600, Inconel 718, Inconel x 750, etc.), a polymer (e.g.,  
20 polyvinylchloride, polypropylene, polycarbonate, etc.), a composite or a laminate (e.g., comprising fiberglass, carbon fiber, bamboo, Kevlar, etc.), or the like. The deployment actuator may be of any shape and/or size. For example, the deployment actuator may have a generally domed shape (e.g., as in a snap dome), and be circular (no legs), or the deployment actuator may have other shapes, e.g., oblong, triangular (3 legs), square (4  
25 legs), pentagonal (5 legs), hexagonal (6 legs), spiderlegged, starlike, clover-shaped (with any number of lobes, e.g., 2, 3, 4, 5, etc.), or the like. The deployment actuator may have, in some embodiments, a hole, dimple, or button in the middle. The deployment actuator may also have a serrated disc or a wave shape. In some cases, the substance transfer component may be mounted on the deployment actuator. In other cases,  
30 however, the substance transfer component is mounted on a separate structure which is driven or actuated upon movement of the deployment actuator.

In one set of embodiments, the deployment actuator is not planar, and has a portion that can be in a first position (a “cocked” or pre-deployed position) or a second position (a “fired” or deployed position), optionally separated by a relatively high energy configuration. In some cases, the pre-deployed position may be at a higher energy level than the deployed position. In some cases, both the first position and the second position are stable (i.e., the structure is bistable), although conversion between the first position and the second position requires the structure to proceed through an unstable configuration.

In some cases, surprisingly, the distance or separation between the first position and the second position is relatively small. Such distances or separations may be achieved using snap domes or other configurations such as those described herein, in contrast to springs or other devices which require longer translational or other movements. For example, the perpendicular distance (i.e., in a direction away from the skin) in the deployment actuator between the top of the structure and the bottom of the structure (excluding the substance transfer component) when the device containing the structure is placed on the skin of a subject may be no more than about 5 mm, no more than about 4 mm, no more than about 3 mm, no more than about 2 mm, no more than about 1 mm in some cases, no more than about 0.8 mm, no more than about 0.5 mm, or no more than about 0.3 mm. In one set of embodiments, the distance is between about 0.3 mm and about 1.5 mm. In another set of embodiments, the deployment actuator may have a greatest lateral dimension (parallel to the skin) when the device containing the structure is placed on the skin of a subject of no more than about 50 mm, no more than about 40 mm, no more than about 30 mm, no more than about 25 mm, no more than about 20 mm, no more than about 15 mm, no more than about 5 mm, no more than about 4 mm, no more than about 3 mm, no more than about 2 mm, no more than about 1 mm in some cases, no more than about 0.8 mm, no more than about 0.5 mm, or no more than about 0.3 mm. In one set of embodiments, the distance is between about 0.3 mm and about 1.5 mm.

Use of device 1100 will now be described in the context of receiving a substance such as blood from a subject. Device 1100 is placed against the skin of a subject such that at least a portion of surface 1104 contacts the skin. Prior to use, a cover member (not shown) can cover surface 1104 of the device and can cover region 1114, to protect

surface 1104 and region 1114 from contaminants, etc. optionally maintaining the interior of the device in a sterile condition. The cover can be peeled off or otherwise removed from the device, and the device placed against the skin, optionally adhering to the skin. Vacuum actuation component 1140 can be actuated to expose channel 1132 and region  
5 1114 to vacuum at any time, including before, simultaneously, or after actuation of substance transfer component 1108. In one arrangement, vacuum actuation component 1140 is actuated to apply vacuum to region 1114 prior to actuation to substance transfer component 1108, thereby to create a vacuum against the skin proximate region 1114 prior to use. Actuation of device actuator 1116 can take place before or after deployment  
10 of vacuum.

When device actuator 1116 is actuated by a user (e.g., when proximal portion 1118 is depressed downwardly as shown in the figure), distal portion 1120 engages skin insertion objects 1108 (optionally via flexible structure 1112) to drive it toward the skin. In some embodiments, foil 1128 is first broken, then retraction actuator 1126 is  
15 compressed, then retraction actuator 1126 is broken, before flexible structure 1112 is stretched and the deployment actuator 1122 of the device fires or is actuated. Membranes or other members 1112, 1128, or 1130 may have, in some cases, sufficient flexibility and/or elasticity to allow actuator 1116 to drive skin insertion objects 1108 sufficiently distally (downwardly, as shown) to engage the skin of the subject and carry  
20 out the desired function of the device. Various gaskets, bearings, or membranes as shown can be used for this function. Where support member 1128 is a foil or the like used for the purpose of initially separating vacuum reservoir 1138 from channel 1132 (e.g., prior to use), when device actuator 1116 is moved downwardly, vacuum actuation component 1140 may rupture support member 1128 proximate actuator 1116, or flexibly  
25 deform as need be, so long as member 1130 (or another component) serves to allow device actuator 1116 to move slidably within the device while maintaining sufficient vacuum in vacuum reservoir 1138 and related channels for use of the device.

When skin insertion objects 1108 engage the skin of the subject and facilitates receiving of a substance from the skin and/or from beneath the skin of the subject, a  
30 vacuum can draw the substance into region 1114, through channel or channels 1132, and into substance collection reservoir 1136. In this process, device actuator 1116 first urges deployment actuator 1122 from its first stable configuration to a relatively unstable



configuration and beyond that point, at which point the deployment actuator 1122 rapidly moves to a second stable configuration associated with downward driving of device actuator 1116 to quickly drive access substance transfer component 1108 proximate the skin.

5           After that point, if it is desirable for access substance transfer component 1108 to be received from the skin, then a variety of techniques can be used to do so. In the device illustrated, retraction actuator 1126 drives holder 1124 upwardly, retracting structure 1122 and device actuator 1116 from substance transfer component 1108. At that point, device actuator 1116 can be operably linked to transfer component 1108 and  
10   retract the transfer component, or it can move freely relative to substance transfer component 1108, whereby flexible structure 1112 (e.g., an elastic membrane) or other component can retract substance transfer component 1108 from the skin. The retraction actuator 1126 may include any suitable retraction component. Again, in the device illustrated, retraction actuator 1126 can itself be a reversibly deformable structure such as  
15   a leaf spring, coil spring, foam, or the like. During use, when device actuator 1116 is driven downwardly, retraction actuator 1126 is first compressed and, depending upon the size and arrangement of components 1126, 1124, 1122, 1116 and 1108, during compression, substance transfer component 1108 can be driven downwardly to some extent. At the point at which retraction actuator 1126 is compressed and provides a  
20   sufficient resistance force, deployment actuator 1122 can be urged from its first configuration through an unstable configuration and can return to its second configuration, driving substance transfer component 1108 against the skin. Then, upon release of user pressure (or other actuation, which can be automatic) from actuator 1116, retraction actuator 1126 can expand and, with structure 1122 optionally remaining in its  
25   second, downwardly-driven low-energy configuration, actuator 1116 can be retracted and substance transfer component 1108 retracted from the skin.

Referring now to Figs. 12A and 12B, device 1150 is illustrated schematically. Device 1150 is similar to and can be considered essentially identical to device 1100 in all aspects other than those described here with respect to Figs. 12A and 12B. As such, the  
30   reader will observe that not all components are provided, although other components similar to those of device 1100 can exist. One way in which device 1150 differs from device 1100 is that in device 1150, in the pre-deployment or post-deployment retracted

configuration, membrane 1112 is drawn proximally (upwardly) as illustrated in Fig. 12B. Membrane 1112 is in a less-stressed lower-energy configuration as shown in Fig. 12A when retraction actuator 1126 is compressed and substance transfer component 1108 is driven proximate the skin. Devices 1100, 1150, and other similar devices are one way to enact a deployment actuator that can move a substance transfer component 1108 relative to the skin in particularly advantageous ways. Examples of deployment actuators include, in addition to the examples shown in Figs. 11 and 12, blasting caps, explosives, other chemical reactions, solenoids or other electrical interactions, pneumatics (e.g., compressed air), other thermal interactions or mechanical interactions, or the like.

In one set of embodiments, the deployment actuator may move substance transfer component 1108 from a fully pre-deployed position (e.g., as shown in Fig. 11) to a fully deployed position in which substance transfer component 1108 is fully engaged with the skin, in a short period of time. In one embodiment, that period of time is less than about 0.01 seconds, and in other embodiments, less than about 0.009 seconds, less than about 0.008 seconds, less than about 0.007 seconds, less than about 0.006 seconds, less than about 0.005 seconds, less than about 0.004 seconds, less than about 0.003 seconds, less than about 0.002 seconds, less than about 0.001 seconds, less than about 0.0005 seconds, less than about 0.00025, or less than about 0.0001 seconds.

In some embodiments, the distance between the fully pre-deployed position and the fully deployed position is no more than about 1,000 microns, no more than about 2,500 microns, or no more than about 5,000 microns.

In another embodiment, substance transfer component 1108 moves quickly relative to skin during deployment via the deployment actuator, reaching a speed of at least about 4 m/s, at least about 5 m/s, at least about 6 m/s, at least about 7 m/s, at least about 8 m/s, at least about 10 m/s, at least about 12 m/s, at least about 15 m/s, or at least about 20 m/s at the point at which substance transfer component 1108 first touches the skin during deployment.

In some cases, substance transfer component 1108 achieves relatively high accelerations due to the deployment actuator. For example, in some cases, the deployment actuator can produce average accelerations (e.g., average acceleration from start of movement to a position where a substance transfer component first contacts a subject) of at least about 4 m/s<sup>2</sup>, about 6 m/s<sup>2</sup>, about 8 m/s<sup>2</sup>, about 10 m/s<sup>2</sup>, about 12 m/s<sup>2</sup>,

about 15 m/s<sup>2</sup>, or about 20 m/s<sup>2</sup>, at least about 30 m/s<sup>2</sup>, at least about 50 m/s<sup>2</sup>, at least about 100 m/s<sup>2</sup>, at least about 300 m/s<sup>2</sup>, at least about 500 m/s<sup>2</sup>, at least about 1,000 m/s<sup>2</sup>, at least about 3,000 m/s<sup>2</sup>, at least about 5,000 m/s<sup>2</sup>, at least about 10,000 m/s<sup>2</sup>, at least about 30,000 m/s<sup>2</sup>, at least about 50,000 m/s<sup>2</sup>, at least about 60,000 m/s<sup>2</sup>, at least about 70,000 m/s<sup>2</sup>, at least about 100,000 m/s<sup>2</sup>, at least about 200,000 m/s<sup>2</sup>, or at least about 300,000 m/s<sup>2</sup>. In some cases, the deployment actuator can produce instantaneous accelerations of at least about 4 m/s<sup>2</sup>, about 6 m/s<sup>2</sup>, about 8 m/s<sup>2</sup>, about 10 m/s<sup>2</sup>, about 12 m/s<sup>2</sup>, about 15 m/s<sup>2</sup>, or about 20 m/s<sup>2</sup>, at least about 30 m/s<sup>2</sup>, at least about 50 m/s<sup>2</sup>, at least about 100 m/s<sup>2</sup>, at least about 300 m/s<sup>2</sup>, at least about 500 m/s<sup>2</sup>, at least about 1,000 m/s<sup>2</sup>, at least about 3,000 m/s<sup>2</sup>, at least about 5,000 m/s<sup>2</sup>, at least about 10,000 m/s<sup>2</sup>, at least about 30,000 m/s<sup>2</sup>, at least about 50,000 m/s<sup>2</sup>, at least about 60,000 m/s<sup>2</sup>, at least about 70,000 m/s<sup>2</sup>, at least about 80,000 m/s<sup>2</sup>, at least about 80,000 m/s<sup>2</sup>, at least about 100,000 m/s<sup>2</sup>, at least about 200,000 m/s<sup>2</sup>, or at least about 300,000 m/s<sup>2</sup>.

Average acceleration is used to mean the rate of change of velocity over the entire time period from the pre-deployed position to the deployed position, and instantaneous acceleration is used to mean the acceleration at a specific point in time during the time period. The average acceleration and the instantaneous accelerations may be determined using high-speed imaging analysis. High speed imaging is used to capture a sequence of video frames with very short time steps between frames. In one example, the time step between frames may be 66 microseconds, although other time steps are possible depending on imaging equipment capability and/or the total capture time. Each video frame captures the position of a moving object at a specific moment in time. Using this data, position as a function of time may be plotted. An equation that is fit to this data approximates position as a function of time. The second derivative of the position equation is an equation for instantaneous acceleration as a function of time. The acceleration equation can then be used to calculate the instantaneous acceleration at any given point in time.

In some embodiments, the substance transfer component 1108 is accelerated for relatively short periods of time, e.g., less than about 1 second, less than about 300 milliseconds, less than about 100 milliseconds, less than about 30 milliseconds, less than about 10 milliseconds, less than about 3 milliseconds, or less than about 1 millisecond, and/or over relatively short distances, e.g., less than about 5 millimeters, less than about

4 millimeters, less than about 3 millimeters, less than about 2 millimeters, less than about 1 millimeter, less than about 800 micrometers, less than 600 micrometers, less than 500 micrometers, less than 400 micrometers, less than about 300 micrometers, less than about 200 micrometers, less than about 100 micrometers, less than about 50  
5 micrometers, etc. Significant forces can be applied to substance transfer component 1108 as it moves relative to the skin via the deployment actuator. In another set of embodiments, substance transfer component 1108, at the point at which it first contacts the skin, is driven by a force created at least in part by the deployment actuator of at least about 6 micronewtons, about 8 micronewtons, about 10 micronewtons, about 12  
10 micronewtons, or about 15 micronewtons.

Significant forces can be applied to substance transfer component 1108 as it moves relative to the skin via the deployment actuator. In another set of embodiments, substance transfer component 1108, at the point at which it first contacts the skin, is driven by a force created at least in part by the deployment actuator of at least about 6  
15 micronewtons, about 8 micronewtons, about 10 micronewtons, about 12 micronewtons, or about 15 micronewtons.

In another set of embodiments, substance transfer component 1108 applies a pressure to the skin, during deployment caused by the deployment actuator, of at least about  $100 \text{ N/m}^2$ , at least about  $300 \text{ N/m}^2$ , at least about  $1,000 \text{ N/m}^2$ , at least about  $3,000$   
20  $\text{N/m}^2$ , etc. In force assessment, the area can be measured as the area of skin displaced by the transfer component at full deployment, e.g., the area of the skin ruptured by the total of the cross sectional area of all substance transfer components inserted into the skin, at the top surface of the skin.

In some cases, the substance transfer component is forced into the skin via the  
25 deployment actuator with a force sufficient to insert the substance transfer component into or through the skin to an average depth of at least about 60% of the substance transfer component (or the average length of the substance transfer components, if more than one is used, e.g., as in an array of microneedles). In some cases, the depth is at least about 65%, at least about 70%, at least about 75%, at least about 80%, at least about  
30 85%, at least about 90%, or at least about 95% of the substance transfer component, e.g., the length of the needle or the microneedle inserted into the skin.

Devices of the invention can provide significant advantage in some embodiments. For example, deployment actuators able to move substance transfer components in short time periods, and/or at high velocities, and/or with high forces, and/or with high pressure, and/or drive relatively short substance transfer components such as skin  
5 insertion objects or microneedles relatively deeply into the skin and/or through the skin, and/or any combination of the above can provide significant advantage. In some embodiments, these features can provide better control of substance delivery or receipt. Better mechanical stability can be provided in some cases by shorter substance transfer components (e.g., bending and/or buckling can be avoided) and relatively shorter  
10 substance transfer components, designed to be driven relatively completely (for example, through nearly all of their entire length) into the skin may offer better control of penetration in some embodiments. If better control of penetration can be achieved, better delivery or receiving can also be achieved in some cases, for example, resulting in less pain or essentially painless deployment.

15 Moreover, if substance transfer components are used to deliver a substance such as a pharmaceutical composition into or through the skin, more precise delivery can be provided, according to certain embodiments. With better, precise control over depth of insertion of the substance transfer components (e.g., by using devices designed to insert the substance transfer components essentially fully), and/or the substance transfer  
20 components contain and/or are coated with a pharmaceutical composition, then more control exists over the amount of pharmaceutical substance inserted into the skin by the substance transfer components, in some embodiments. Furthermore, quick and/or high velocity, and/or high force and/or pressure application of skin insertion objects to the skin may in certain embodiments result in lower pain or painless deployment.

25 According to one set of embodiments, many devices as discussed herein use various techniques for delivering and/or receiving fluid, for example, in connection with substance transfer components, skin insertion objects, or the like. For example, one or more needles and/or microneedles, a hygroscopic agent, a cutter or other piercing element, an electrically-assisted system, or the like may be used in conjunction with a  
30 snap dome or other device as described above. Additional examples of such techniques are described herein and/or in the applications incorporated herein. It is to be understood that, generally, fluids may be delivered and/or received in a variety of ways, and various

systems and methods for delivering and/or receiving fluid from the skin are discussed below and/or in the applications incorporated herein. In some embodiments, for example, techniques for piercing or altering the surface of the skin to transport a fluid are discussed, for example, using a needle such as a hypodermic needle or microneedles, 5 chemicals applied to the skin (e.g., penetration enhancers), jet injectors or other techniques such as those discussed below, etc.

As an example, in one embodiment, a needle such as a hypodermic needle can be used to deliver and/or receive fluid to or from the skin. Hypodermic needles are well-known to those of ordinary skill in the art, and can be obtained commercially with a 10 range of needle gauges. For example, the needle may be in the 20-30 gauge range, or the needle may be 32 gauge, 33 gauge, 34 gauge, etc.

If needles are present, the needles may be of any suitable size and length, and may be solid or hollow. The needles may have any suitable cross-section (e.g., perpendicular to the direction of penetration), for example, circular, square, oval, 15 elliptical, rectangular, rounded rectangle, triangular, polygonal, hexagonal, irregular, etc. For example, the needle may have a length of less than about 5 mm, less than about 4 mm, less than about 3 mm, less than about 2 mm, less than about 1 mm, less than about 800 micrometers, less than 600 micrometers, less than 500 micrometers, less than 400 micrometers, less than about 300 micrometers, less than about 200 micrometers, less 20 than about 175 micrometers, less than about 150 micrometers, less than about 125 micrometers, less than about 100 micrometers, less than about 75 micrometers, less than about 50 micrometers, etc. The needle may also have a largest cross-sectional dimension of less than about 5 mm, less than about 4 mm, less than about 3 mm, less than about 2 mm, less than about 1 mm, less than about 800 micrometers, less than 600 micrometers, 25 less than 500 micrometers, less than 400 micrometers, less than about 300 micrometers, less than about 200 micrometers, less than about 175 micrometers, less than about 150 micrometers, less than about 125 micrometers, less than about 100 micrometers, less than about 75 micrometers, less than about 50 micrometers, etc. For example, in one embodiment, the needle may have a rectangular cross section having dimensions of 175 30 micrometers by 50 micrometers. In one set of embodiments, the needle may have an aspect ratio of length to largest cross-sectional dimension of at least about 2:1, at least

about 3:1, at least about 4:1, at least 5:1, at least about 7:1, at least about 10:1, at least about 15:1, at least about 20:1, at least about 25:1, at least about 30:1, etc.

In one embodiment, the needle is a microneedle. As an example, microneedles such as those disclosed in U.S. Patent No. 6,334,856, issued January 1, 2002, entitled  
5 “Microneedle Devices and Methods of Manufacture and Use Thereof,” by Allen, *et al.*, may be used to deliver and/or receive fluids or other materials to or from a subject. The microneedles may be hollow or solid, and may be formed from any suitable material, e.g., metals, ceramics, semiconductors, organics, polymers, and/or composites. Examples include, but are not limited to, pharmaceutical grade stainless steel, titanium,  
10 nickel, iron, gold, tin, chromium, copper, alloys of these or other metals, silicon, silicon dioxide, and polymers, including polymers of hydroxy acids such as lactic acid and glycolic acid polylactide, polyglycolide, polylactide-co-glycolide, and copolymers with polyethylene glycol, polyanhydrides, polyorthoesters, polyurethanes, polybutyric acid, polyvaleric acid, polylactide-co-caprolactone, polycarbonate, polymethacrylic acid,  
15 polyethylenevinyl acetate, polytetrafluorethylene, polymethyl methacrylate, polyacrylic acid, or polyesters.

In some cases, more than one microneedle may be used. For example, arrays of microneedles may be used, and the microneedles may be arranged in the array in any suitable configuration, e.g., periodic, random, etc. In some cases, the array may have 3  
20 or more, 4 or more, 5 or more, 6 or more, 10 or more, 15 or more, 20 or more, 35 or more, 50 or more, 100 or more, or any other suitable number of microneedles. In some embodiments, the device may have at least 3 but no more than 5 needles or microneedles (or other skin insertion objects), at least 6 but no more than 10 needles or microneedles, or at least 11 but no more than 20 needles or microneedles. Typically, a microneedle  
25 will have an average cross-sectional dimension (e.g., diameter) of less than about a micron. It should be understood that references to “needle” or “microneedle” as discussed herein are by way of example and ease of presentation only, and that in other embodiments, more than one needle and/or microneedle may be present in any of the descriptions herein.

30 Those of ordinary skill in the art can arrange needles relative to the skin for these purposes including, in one embodiment, introducing needles into the skin at an angle, relative to the skin’s surface, other than 90°, i.e., to introduce a needle or needles into the

skin in a slanting fashion so as to limit the depth of penetration. In another embodiment, however, the needles may enter the skin at approximately 90°.

In some cases, the microneedles may be present in an array selected such that the density of microneedles within the array is between about 0.5 needles/mm<sup>2</sup> and about 10  
5 needles/mm<sup>2</sup>, and in some cases, the density may be between about 0.6 needles/mm<sup>2</sup> and about 5 needles/mm<sup>2</sup>, between about 0.8 needles/mm<sup>2</sup> and about 3 needles/mm<sup>2</sup>, between about 1 needles/mm<sup>2</sup> and about 2.5 needles/mm<sup>2</sup>, or the like. In some cases, the needles may be positioned within the array such that no two needles are closer than about 1 mm, about 0.9 mm, about 0.8 mm, about 0.7 mm, about 0.6 mm, about 0.5 mm, about 0.4  
10 mm, about 0.3 mm, about 0.2 mm, about 0.1 mm, about 0.05 mm, about 0.03 mm, about 0.01 mm, etc.

In another set of embodiments, the needles (or microneedles) may be chosen such that the area of the needles (determined by determining the area of penetration or perforation on the surface of the skin of the subject by the needles) allows for adequate  
15 flow of fluid to or from the subject. The microneedles may be chosen to have smaller or larger areas (or smaller or large diameters), so long as the area of contact for the microneedles to the skin is sufficient to allow adequate blood flow from the subject to the device. The needles or microneedles may have any suitable cross-sectional area. For example, in certain embodiments, each microneedle may be selected to have a cross-  
20 sectional area of at least 5 nm<sup>2</sup>, at least about 100 nm<sup>2</sup>, at least about 500 nm<sup>2</sup>, at least about at least about 1,000 nm<sup>2</sup>, at least about 3,000 nm<sup>2</sup>, at least about 10,000 nm<sup>2</sup>, at least about 30,000 nm<sup>2</sup>, at least about 100,000 nm<sup>2</sup>, at least about 300,000 nm<sup>2</sup>, at least about 1 microns<sup>2</sup>, at least about 3 microns<sup>2</sup>, at least about 10 microns<sup>2</sup>, at least about 30 microns<sup>2</sup>, at least about 100 microns<sup>2</sup>, at least about 300 microns<sup>2</sup>, at least about 500  
25 microns<sup>2</sup>, at least about 1,000 microns<sup>2</sup>, at least about 2,000 microns<sup>2</sup>, at least about 2,500 microns<sup>2</sup>, at least about 3,000 microns<sup>2</sup>, at least about 5,000 microns<sup>2</sup>, at least about 8,000 microns<sup>2</sup>, at least about 10,000 microns<sup>2</sup>, or at least about 25,000 microns<sup>2</sup>. For example, in certain embodiments, the microneedles may be selected to have a combined skin-penetration area of at least about 500 nm<sup>2</sup>, at least about 1,000 nm<sup>2</sup>, at  
30 least about 3,000 nm<sup>2</sup>, at least about 10,000 nm<sup>2</sup>, at least about 30,000 nm<sup>2</sup>, at least about 100,000 nm<sup>2</sup>, at least about 300,000 nm<sup>2</sup>, at least about 1 microns<sup>2</sup>, at least about 3 microns<sup>2</sup>, at least about 10 microns<sup>2</sup>, at least about 30 microns<sup>2</sup>, at least about 100



microns<sup>2</sup>, at least about 300 microns<sup>2</sup>, at least about 500 microns<sup>2</sup>, at least about 1,000 microns<sup>2</sup>, at least about 2,000 microns<sup>2</sup>, at least about 2,500 microns<sup>2</sup>, at least about 3,000 microns<sup>2</sup>, at least about 5,000 microns<sup>2</sup>, at least about 8,000 microns<sup>2</sup>, at least about 10,000 microns<sup>2</sup>, at least about 35,000 microns<sup>2</sup>, at least about 100,000 microns<sup>2</sup>, etc., depending on the application.

The needles or microneedles may have any suitable length, and the length may be, in some cases, dependent on the application. For example, needles designed to only penetrate the epidermis may be shorter than needles designed to also penetrate the dermis, or to extend beneath the dermis or the skin. In certain embodiments, the needles or microneedles may have a maximum penetration into the skin, or insertion depth, of no more than about 3 mm, no more than about 2 mm, no more than about 1.75 mm, no more than about 1.5 mm, no more than about 1.25 mm, no more than about 1 mm, no more than about 900 microns, no more than about 800 microns, no more than about 750 microns, no more than about 600 microns, no more than about 500 microns, no more than about 400 microns, no more than about 300 microns, no more than about 200 microns, no more than about 175 micrometers, no more than about 150 micrometers, no more than about 125 micrometers, no more than about 100 micrometers, no more than about 75 micrometers, no more than about 50 micrometers, etc. In certain embodiments, the needles or microneedles may be selected so as to have a maximum insertion depth of at least about 50 micrometers, at least about 100 micrometers, at least about 300 micrometers, at least about 500 micrometers, at least about 1 mm, at least about 2 mm, at least about 3 mm, etc.

In one set of embodiments, the needles (or microneedles) may be coated. For example, the needles may be coated with a substance that is delivered when the needles are inserted into the skin. For instance, the coating may comprise heparin, an anticoagulant, an anti-inflammatory compound, an analgesic, an anti-histamine compound or a vasodilator to assist with the flow of blood from the skin of the subject. The coating may comprise a drug or other therapeutic agent such as those described herein. The drug or other therapeutic agent may be one used for localized delivery (e.g., of or proximate the region to which the coated needles or microneedles are applied), and/or the drug or other therapeutic agent may be one intended for systemic delivery within the subject.

At least some the skin insertion objects may be at least partially coated by a substance such as a drug, analgesic or agent by using dip or spray coating or other suitable technique. Thus, the substance may be delivered to the skin by the substance dissolving or otherwise detaching from the substance transfer component at or in the skin or other subject site. Alternately, the substance may be delivered after a substance transfer component penetrates the subject, e.g., in a way similar to a hypodermic needle. For example, a skin insertion object of the substance transfer component may be inserted into the skin, and a substance may be pumped or pushed through a hole, groove or other channel of the skin insertion object (e.g., by a high pressure gas).

A drug may be any composition which possesses therapeutic, prophylactic, or diagnostic properties *in vivo*, for example when administered to an animal, including mammals, such as humans. The drug can be for local treatment or for regional or systemic therapy. The drug can be or include a peptide, protein, carbohydrate (including monosaccharides, oligosaccharides, and polysaccharides), nucleoprotein, mucoprotein, lipoprotein, glycoprotein, nucleic acid molecules (including any form of DNA such as cDNA, RNA, or a fragment thereof, oligonucleotides, and genes), nucleotide, nucleoside, lipid, biologically active organic or inorganic molecules, or combination thereof. Examples of suitable therapeutic and/or prophylactic active agents include anti-infectives, analgesics, anti-inflammatories, steroids, decongestants, neuroactive agents, anesthetics, and sedatives. Examples of suitable diagnostic agents include radioactive isotopes and radioopaque agents, metals, gases, labels including chromatographic, fluorescent, or enzymatic labels.

Examples of biologically active polypeptides or proteins include, but are not limited to, glucagon, glucagon-like peptides such as, GLP-1, GLP-2 or other GLP analogs, derivatives or agonists of Glucagon Like Peptides, exendins such as, exendin-3 and exendin-4, derivatives, agonists and analogs thereof, vasoactive intestinal peptide (VIP), immunoglobulins, antibodies, cytokines (e.g., lymphokines, monokines, chemokines), interleukins, macrophage activating factors, interferons, erythropoietin, nucleases, tumor necrosis factor, colony stimulating factors (e.g., G-CSF), insulin, enzymes (e.g., superoxide dismutase, plasminogen activator, etc.), tumor suppressors, blood proteins, hormones and hormone analogs and agonists (e.g., follicle stimulating hormone, growth hormone, adrenocorticotrophic hormone, and luteinizing hormone

releasing hormone (LHRH)), vaccines (e.g., tumoral, bacterial and viral antigens), antigens, blood coagulation factors, growth factors (NGF and EGF), gastrin, GRH, antibacterial peptides such as defensin, enkephalins, bradykinins, calcitonin and muteins, analogs, truncation, deletion and substitution variants and pharmaceutically acceptable salts of all the foregoing. Suitable analgesics include but are not limited to lidocaine, bupivacaine, and tetracaine. Suitable steroids include but are not limited to cortisone, betametasone, budesonide and fluticasone.

In one set of embodiments, the needles or microneedles may be used to deliver a drug into the skin of a subject. The needles or microneedles may be at least partially coated, and the coating may comprise a drug or other therapeutic agent such as those described herein. For example, in one set of embodiments, at least about 50%, at least about 60%, at least about 70%, at least about 80%, at least about 90%, or substantially all of a needle or a microneedle may be coated, and one or more than one needle or microneedle may be coated in a device as discussed herein. For instance, at least about 25%, at least about 50%, at least about 60%, at least about 70%, at least about 80%, at least about 90%, or substantially all of the needles or microneedles in a device may comprise a coating.

Without wishing to be bound by any theory, it is believed that, at least in some cases, longer needles or microneedles may be useful for the delivery of a drug or other therapeutic agent. For example, a needle having a greater depth of penetration into the skin may be useful for delivering the drug or other therapeutic agent deeper into the skin, e.g., closer to capillaries within or below the skin, which may minimize the distance the drug needs to travel before being available systemically and allow a more rapid onset of the drug effect. In addition, greater depth of penetration can be useful for delivering greater amounts of drug. A longer needle can have more surface area exposed internally of the subject, relative to a shorter needle (e.g., of the same diameter), and the increased surface area may allow more of the coating containing drug to be exposed internally of the skin. Thus, for example, a greater amount of drug may be delivered per needle or microneedle that enters the skin.

Accordingly, in certain embodiments, relatively long needles or microneedles may be used for the delivery of a drug or other therapeutic agent into the skin, for example. For instance, the average length of the needles or microneedles in the device

may be at least about 200 micrometers, at least about 300 micrometers, at least about 400 micrometers, at least about 500 micrometers, at least about 600 micrometers, at least about 750 micrometers, at least about 800 micrometers, at least about 900 micrometers, at least about 1,000 micrometers, at least about 1,200 micrometers, at least about 1,500 micrometers, at least about 1,700 micrometers, or at least about 2,000 micrometers in some embodiments.

Any of a variety of suitable techniques may be used to coat a needle or a microneedle. For instance, the needle or microneedle may be coated by exposing the needles or microneedles to a liquid containing a substance to be coated thereon. For example, the needles or microneedles may be dipped into a liquid, a liquid may be sprayed on or aerosolized onto the needles or microneedles, an electric field may be used to attract a charged liquid onto the needles or microneedles, etc.

In one embodiment, the fluid is delivered and/or received manually, e.g., by manipulating a plunger on a syringe. In another embodiment, the fluid can be delivered and/or received from the skin mechanically or automatically, e.g., using a piston pump or the like. Fluid may also be received using vacuums such as those discussed herein. For example, vacuum may be applied to a conduit, such as a needle, in fluidic communication with a bodily fluid in order to draw up at least a portion of the fluid from the pooled region. In yet another embodiment, fluid is received using capillary action (e.g., using a microfluidic channel or hypodermic needle having a suitably narrow inner diameter). In still another embodiment, pressure may be applied to force fluid out of the needle.

In some embodiments, a substance is delivered to a subject from a device. In cases where the needle or other skin insertion object is coated with a drug or other substance, the device may deliver the drug or substance to a subject by penetrating the skin with the coated needle. The substance may be delivered to or beneath the skin by the substance dissolving or otherwise detaching from the substance transfer component at the skin or other subject site. The device may or may not cause fluid release from the subject. In some cases, fluid from the subject is not received into the device and a vacuum source is not needed. Also, in some cases, the device may additionally or alternatively deliver a fluid drug or other fluid substance to a subject. The fluid

substance may delivered to or beneath the skin through hollow needles that transfer fluid from the device to the subject.

As still another example, pressurized fluids may be used to deliver fluids or other materials into the skin, for instance, using a jet injector or a “hypospray.” Typically, such devices produce a high-pressure “jet” of liquid or powder (e.g., a biocompatible liquid, such as saline) that drives material into the skin, and the depth of penetration may be controlled, for instance, by controlling the pressure of the jet. The pressure may come from any suitable source, e.g., a standard gas cylinder or a gas cartridge. A non-limiting example of such a device can be seen in U.S. Patent No. 4,103,684, issued August 1, 1978, entitled “Hydraulically Powered Hypodermic Injector with Adapters for Reducing and Increasing Fluid Injection Force,” by Ismach.

In some embodiments, fluid may be received using a hygroscopic agent applied to the surface of the skin, or proximate the skin. For example, a device as described herein may contain a hygroscopic agent. In some cases, pressure may be applied to drive the hygroscopic agent into the skin. Hygroscopic agents typically are able to attract water from the surrounding environment, for instance, through absorption or adsorption. Non-limiting examples of hygroscopic agents include sugar, honey, glycerol, ethanol, methanol, sulfuric acid, methamphetamine, iodine, many chloride and hydroxide salts, and a variety of other substances. Other examples include, but are not limited to, zinc chloride, calcium chloride, potassium hydroxide, or sodium hydroxide. In some cases, a suitable hygroscopic agent may be chosen based on its physical or reactive properties, e.g., inertness or biocompatibility towards the skin of the subject, depending on the application.

In some embodiments, the device may comprise a cutter able to cut or pierce the surface of the skin. The cutter may comprise any mechanism able to create a path through which fluids may be delivered and/or received from the skin. For example, the cutter may comprise a hypodermic needle, a blade (e.g., a knife blade, a serrated blade, etc.), a piercing element (e.g., a lancet or a solid or a hollow needle), or the like, which can be applied to the skin to create a suitable conduit for the delivery and/or receiving of fluid from the skin. In one embodiment, a cutter is used to create such a pathway and removed, then fluid may be delivered and/or received via this pathway. In another

embodiment, the cutter remains in place within the skin, and fluid may be delivered and/or received through a conduit within the cutter.

In some embodiments, fluid may be received using an electric charge. For example, reverse iontophoresis may be used. Without wishing to be bound by any theory, reverse iontophoresis uses a small electric current to drive charged and highly polar compounds across the skin. Since the skin is negatively charged at physiologic pH, it acts as a permselective membrane to cations, and the passage of counterions across the skin induces an electroosmotic solvent flow that may carry neutral molecules in the anode-to-cathode direction. Components in the solvent flow may be analyzed as described elsewhere herein. In some instances, a reverse iontophoresis apparatus may comprise an anode cell and a cathode cell, each in contact with the skin. The anode cell may be filled, for example, with an aqueous buffer solution (i.e., aqueous Tris buffer) having a pH greater than 4 and an electrolyte (i.e. sodium chloride). The cathode cell can be filled with aqueous buffer. As one example, a first electrode (e.g., an anode) can be inserted into the anode cell and a second electrode (e.g., a cathode) can be inserted in the cathode cell. In some embodiments, the electrodes are not in direct contact with the skin.

A current may be applied to induce reverse iontophoresis, thereby receiving a fluid from the skin. The current applied may be, for example, greater than 0.01 mA, greater than 0.3 mA, greater than 0.1 mA, greater than 0.3 mA, greater than 0.5 mA, or greater than 1 mA. It should be understood that currents outside these ranges may be used as well. The current may be applied for a set period of time. For example, the current may be applied for greater than 30 seconds, greater than 1 minute, greater than 5 minutes, greater than 30 minutes, greater than 1 hour, greater than 2 hours, or greater than 5 hours. It should be understood that times outside these ranges may be used as well.

In one set of embodiments, the device may comprise a substance transfer component in the form of an apparatus for ablating the skin. Without wishing to be bound by any theory, it is believed that ablation comprises removing a microscopic patch of stratum corneum (i.e., ablation forms a micropore), thus allowing access to bodily fluids. In some cases, thermal, radiofrequency, and/or laser energy may be used for ablation. In some instances, thermal ablation may be applied using a heating element.

Radiofrequency ablation may be carried out using a frequency and energy capable of heating water and/or tissue. A laser may also be used to irradiate a location on the skin to remove a portion. In some embodiments, the heat may be applied in pulses such that a steep temperature gradient exists essentially perpendicular to the surface of the skin. For example, a temperature of at least 100 °C, at least 200 °C, at least 300 °C, or at least 400 °C may be applied for less than 1 second, less than 0.1 seconds, less than 0.01 seconds, less than 0.005 seconds, or less than 0.001 seconds.

In some embodiments, the device may comprise a substance transfer component in the form of a mechanism for taking a solid sample of tissue. For example, a solid tissue sample may be acquired by methods such as scraping the skin or cutting out a portion. Scraping may comprise a reciprocating action whereby an instrument is scraped along the surface of the skin in two or more directions. Scraping can also be accomplished by a rotating action, for example parallel to the surface of the skin and in one direction (i.e., with a roller drum) or parallel to the surface of the skin and in a circular manner (i.e., with a drilling instrument). A cutting mechanism may comprise a blade capable of making one or more incisions and a mechanism for removing a portion of tissue (i.e., by suction or mechanically picking up) or may use a pincer mechanism for cutting out a portion of tissue. A cutting mechanism may also function by a coring action. For example, a hollow cylindrical device can be penetrated into the skin such that a cylindrical core of tissue may be removed. A solid sample may be analyzed directly or may be liquefied prior to analysis. Liquefaction can comprise treatment with organic solvents, enzymatic solutions, surfactants, etc.

The device may also contain, in some embodiments, a vacuum source. In some cases, the vacuum source is one that is self-contained within the device, i.e., the device need not be connected to an external vacuum source (e.g., a house vacuum) during use of the device to receive blood from the skin. For example, in one set of embodiments, the vacuum source may include a vacuum chamber having a pressure less than atmospheric pressure before blood (or other fluid) is received into the device, i.e., the vacuum chamber is at a “negative pressure” (that is, negative relative to atmospheric pressure) or a “vacuum pressure” (or just having a “vacuum”). For example, the vacuum in the vacuum chamber may be at least about 50 mmHg, at least about 100 mmHg, at least about 150 mmHg, at least about 200 mmHg, at least about 250 mmHg, at least about 300

mmHg, at least about 350 mmHg, at least about 400 mmHg, at least about 450 mmHg, at least about 500 mmHg, at least 550 mmHg, at least 600 mmHg, at least 650 mmHg, at least about 700 mmHg, or at least about 750 mmHg, i.e., below atmospheric pressure. However, in other embodiments, it should be understood that other pressures may be used and/or that different methods may be used to produce other pressures (greater than or less than atmospheric pressure). As non-limiting examples, an external vacuum or a mechanical device may be used as the vacuum source; various additional examples are discussed in detail herein.

As a specific, non-limiting example, in one embodiment, a device may be used to receive fluid without an external power and/or a vacuum source. Examples of such devices include skin patches, strips, tapes, bandages, or the like. For instance, a skin patch may be contacted with the skin of a subject, and a vacuum created through a change in shape of a portion of the skin patch or other device (e.g., using a shape memory polymer), which may be used to deliver and/or receive fluid from the skin. As a specific example, a shape memory polymer may be shaped to be flat at a first temperature (e.g., room temperature) but curved at a second temperature (e.g., body temperature), and when applied to the skin, the shape memory polymer may alter from a flat shape to a curved shape, thereby creating a vacuum. As another example, a mechanical device may be used to create the vacuum, For example, springs, coils, expanding foam (e.g., from a compressed state), a shape memory polymer, shape memory metal, or the like may be stored in a compressed or wound released upon application to a subject, then released (e.g., unwinding, uncompressing, etc.), to mechanically create the vacuum.

Thus, in some cases, the device is “pre-packaged” with a suitable vacuum source (e.g., a pre-evacuated vacuum chamber); for instance, in one embodiment, the device may be applied to the skin and activated in some fashion to create and/or access the vacuum source. In yet another example, a chemical reaction may be used to create a vacuum, e.g., a reaction in which a gas is produced, which can be harnessed to provide the mechanical force to create a vacuum. In still another example, a component of the device may be able to create a vacuum in the absence of mechanical force. In another example, the device may include a self-contained vacuum actuator, for example, chemical reactants, a deformable structure, a spring, a piston, etc.



In one set of embodiments, the device may be able to create a pressure differential (e.g. a vacuum). The pressure differential may be created by a pressure regulator. As used here, “pressure regulator” is a pressure controller component or system able to create a pressure differential between two or more locations. The pressure differential should be at least sufficient to urge the movement of fluid or other material in accordance with various embodiments of the invention as discussed herein, and the absolute pressures at the two or more locations are not important so long as their differential is appropriate, and their absolute values are reasonable for the purposes discussed herein. For example, the pressure regulator may produce a pressure higher than atmospheric pressure in one location, relative to a lower pressure at another location (atmospheric pressure or some other pressure), where the differential between the pressures is sufficient to urge fluid in accordance with the invention. In another example, the regulator or controller will involve a pressure lower than atmospheric pressure (a vacuum) in one location, and a higher pressure at another location(s) (atmospheric pressure or a different pressure) where the differential between the pressures is sufficient to urge fluid in accordance with the invention. Wherever “vacuum” or “pressure” is used herein, in association with a pressure regulator or pressure differential of the invention, it should be understood that the opposite can be implemented as well, as would be understood by those of ordinary skill in the art, i.e., a vacuum chamber can be replaced in many instances with a pressure chamber, for creating a pressure differential suitable for urging the movement of fluid or other material.

The pressure regulator may be an external source of vacuum (e.g. a lab, clinic, hospital, etc., house vacuum line or external vacuum pump), a mechanical device, a vacuum chamber, pre-packaged vacuum chamber, or the like. In some cases, vacuum may be created manually, e.g., by manipulating a syringe pump, a plunger, or the like, or the low pressure may be created mechanically or automatically, e.g., using a piston pump, a syringe, a bulb, a Venturi tube, manual (mouth) suction, etc., or the like. Vacuum chambers can be used in some embodiments, where the device contains, e.g., regions in which a vacuum exists or can be created (e.g. a variable volume chamber, a change in volume of which will affect vacuum or pressure). A vacuum chamber can

include pre-evacuated (i.e., pre-packaged) chambers or regions, and/or self-contained actuators.

A “self-contained” vacuum (or pressure) regulator means one that is associated with (e.g., on or within) the device, e.g. one that defines an integral part of the device, or  
5 is a separate component constructed and arranged to be specifically connectable to the particular device to form a pressure differential (i.e., not a connection to an external source of vacuum such as a hospital’s, clinic’s, or lab’s house vacuum line, or a vacuum pump suitable for very general use). In some embodiments, the self-contained vacuum source may be actuated in some fashion to create a vacuum within the device. For  
10 instance, the self-contained vacuum source may include a piston, a syringe, a mechanical device such as a vacuum pump able to create a vacuum within the device, and/or chemicals or other reactants that can react to increase or decrease pressure which, with the assistance of mechanical or other means driven by the reaction, can form a pressure differential associated with a pressure regulator. Chemical reaction can also drive  
15 mechanical actuation with or without a change in pressure based on the chemical reaction itself. A self-contained vacuum source can also include an expandable foam, a shape memory material, or the like.

One category of self-contained vacuum or pressure regulators of the invention includes self-contained assisted regulators. These are regulators that, upon actuation  
20 (e.g., the push of a button, or automatic actuation upon, e.g., removal from a package or urging a device against the skin), a vacuum or pressure associated with the device is formed where the force that pressurizes or evacuates a chamber is not the same as the actuation force. Examples of self-contained assisted regulators include chambers evacuated by expansion driven by a spring triggered by actuation, release of a shape-  
25 memory material or expandable material upon actuation, initiation of a chemical reaction upon actuation, or the like.

Another category of self-contained vacuum or pressure regulators of the invention are devices that are not necessarily pre-packaged with pressure or vacuum, but which can be pressurized or evacuated, e.g. by a subject, health care professional at a  
30 hospital or clinic prior to use, e.g. by connecting a chamber of the device to a source of vacuum or pressure. For example, the subject, or another person, may actuate the device

to create a pressure or vacuum within the device, for example, immediately prior to use of the device.

The vacuum or pressure regulator may be a “pre-packaged” pressure or vacuum chamber in the device when used (i.e., the device can be provided ready for use by a subject or practitioner with an evacuated region on or in the device, without the need for any actuation to form the initial vacuum). A pre-packaged pressure or vacuum chamber regulator can, e.g., be a region evacuated (relative to atmospheric pressure) upon manufacture and/or at some point prior to the point at which it is used by a subject or practitioner. For example, a chamber is evacuated upon manufacture, or after manufacture but before delivery of the device to the user, e.g. the clinician or subject. For instance, in some embodiments, the device contains a vacuum chamber having a vacuum of at least about 50 mmHg, at least about 100 mmHg, at least about 150 mmHg, at least about 200 mmHg, at least about 250 mmHg, at least about 300 mmHg, at least about 350 mmHg, at least about 400 mmHg, at least about 450 mmHg, at least about 500 mmHg, at least about 550 mmHg, at least about 600 mmHg, at least about 650 mmHg, at least about 700 mmHg, or at least about 750 mmHg below atmospheric pressure.

In one set of embodiments, a device of the present invention may not have an external power and/or a vacuum source. In some cases, the device is “pre-loaded” with a suitable vacuum source; for instance, in one embodiment, the device may be applied to the skin and activated in some fashion to create and/or access the vacuum source. As one example, a device of the present invention may be contacted with the skin of a subject, and a vacuum created through a change in shape of a portion of the device (e.g., using a shape memory polymer), or the device may contain one or more sealed, self-contained vacuum chambers, where a seal is punctured in some manner to create a vacuum. For instance, upon puncturing the seal, a vacuum chamber may be in fluidic communication with a needle, which can be used to move the skin towards the device, receive fluid from the skin, or the like.

As another example, a shape memory polymer may be shaped to be flat at a first temperature (e.g., room temperature) but curved at a second temperature (e.g., body temperature), and when applied to the skin, the shape memory polymer may alter from a flat shape to a curved shape, thereby creating a vacuum. As yet another example, a mechanical device may be used to create the vacuum, For example, springs, coils,

expanding foam (e.g., from a compressed state), a shape memory polymer, shape memory metal, or the like may be stored in a compressed or wound released upon application to a subject, then released (e.g., unwinding, uncompressing, etc.), to mechanically create the vacuum. Non-limiting examples of shape-memory polymers and  
5 metals include Nitinol, compositions of oligo(epsilon-caprolactone)diol and crystallizable oligo(rho-dioxanone)diol, or compositions of oligo(epsilon-caprolactone)dimethacrylate and *n*-butyl acrylate.

In yet another example, a chemical reaction may be used to create a vacuum, e.g., a reaction in which a gas is produced, which can be harnessed to provide the mechanical  
10 force to create a vacuum. In some embodiments, the device may be used to create a vacuum automatically, once activated, without any external control by a user.

In one set of embodiments, the device contains a vacuum chamber that is also used as a storage chamber to receive blood or other fluid received from the subject into the device. For instance, blood received from a subject through or via the substance  
15 transfer component may enter the vacuum chamber due to its negative pressure (i.e., because the chamber has an internal pressure less than atmospheric pressure), and optionally stored in the vacuum chamber for later use. A non-limiting example is illustrated in Fig. 3. In this figure, device 600 contains vacuum chamber 610, which is connected to substance transfer component 620 (which may include, e.g., one or more  
20 microneedles). Upon activation of vacuum chamber 610 (e.g., using actuator 660, as discussed below), vacuum chamber 610 may be put into fluidic communication with substance transfer component 620. Substance transfer component 620 may accordingly cause negative pressure to be applied to the skin of the subject, for instance, due to the internal pressure within vacuum chamber 610. Fluid (e.g., blood) exiting the skin via  
25 substance transfer component 620 may accordingly be drawn into the device and into vacuum chamber 610, e.g., through conduit 612. The fluid collected by the device can then be analyzed within the device or removed from the device for analysis, storage, etc.

In another set of embodiments, however, the device may include separate vacuum chambers and storage chambers (e.g., chambers to store fluid such as blood from the  
30 subject). The vacuum chamber and storage chambers may be in fluid communication, and may have any suitable arrangement. In some embodiments, the vacuum from the vacuum chamber may be used, at least in part, to receive fluid from the skin, which is

then directed into a storage chamber, e.g., for later analysis or use, for example, as discussed below. As an example, blood may be received into the device, flowing towards a vacuum chamber, but the fluid may be prevented from entering the vacuum chamber. For instance, in certain embodiments, a material permeable to gas but not to a liquid such as blood may be used. For example, the material may be a membrane such as a hydrophilic or hydrophobic membrane having a suitable porosity, a porous structure, a porous ceramic frit, a dissolvable interface (e.g., formed from a salt or a polymer, etc.), or the like.

One non-limiting example is illustrated in Fig. 4. In this figure, device 600 contains vacuum chamber 610 and storage chamber 615. Vacuum chamber 610 can be put in fluidic communication with storage chamber 615 via conduit 612, which contains material 614. Material 614 may be any material permeable to gas but not to a liquid in this example, e.g., material 614 may be a membrane such as a hydrophilic membrane or a hydrophobic membrane that has a porosity that allows gas exchange to occur but does not allow the passage of blood from the subject. When device 600 is actuated using actuator 660, blood (or other fluid) flows through substance transfer component 620 via conduit 661 into collection chamber 615 because of the internal vacuum pressure from vacuum chamber 610, which is not completely impeded by material 614 since it is permeable to gases. However, because of material 614, blood (or other suitable bodily fluid) is prevented from entering vacuum chamber 610, and instead remains in storage chamber 615, e.g., for later analysis or use.

In some embodiments, the flow of blood (or other fluid) into the storage chamber may be controlled using a flow controller. The flow controller may be manually and/or automatically controlled to control the flow of blood. The flow controller may activate or deactivate when a certain amount or volume of fluid has entered the storage chamber in certain cases. For instance, the flow controller may stop blood flow after a predetermined amount or volume of blood has entered the storage chamber, and/or the flow controller may be able to control the internal pressure of the storage chamber, e.g., to a specific level, such as a predetermined level. Examples of suitable flow controllers for the device include, but are not limited to, a membrane, a valve, a dissolvable interface, a gate, or the like.

One non-limiting example of a flow controller is now illustrated with reference to Fig. 5. In this example figure, device 600 includes a vacuum chamber 610 and a storage chamber 615. Fluid entering device 600 via substance transfer component 620 is prevented from entering storage chamber 615 due to flow controller 645 present within conduit 661. However, under suitable conditions, flow controller 645 may be opened, thereby allowing at least some fluid to enter storage chamber 615. In some cases, for instance, storage chamber 615 also contains at least a partial vacuum, although this vacuum may be greater or less than the pressure within chamber 610. In other embodiments, flow controller 645 may initially be open, or be externally controllable (e.g., via an actuator), or the like. In some cases, the flow controller may control the flow of fluid into the device such that, after collection, at least some vacuum is still present in the device.

Thus, in some cases, the device may be constructed and arranged to reproducibly obtain from the subject a controlled amount of fluid, e.g., a controlled amount or volume of blood. The amount of fluid reproducibly obtained from the subject may be controlled, for example, using flow controllers, materials permeable to gas but not to liquids, membranes, valves, pumps, gates, microfluidic systems, or the like, as discussed herein. In particular, it should be noted that the volume of blood or other fluid obtained from the subject need not be strictly a function of the initial vacuum pressure or volume within the device. For example, a flow controller may initially be opened (e.g., manually, automatically, electronically, etc.) to allow fluid to begin entering the device; and when a predetermined condition is reached (e.g., when a certain volume or amount of blood has entered the device), the flow controller may be closed at that point, even if some vacuum pressure remains within the device. In some cases, this control of fluid allows the amount of fluid reproducibly obtained from the subject to be controlled to a great extent. For example, in one set of embodiments, the amount of fluid received from the subject may be controlled to be less than about 1 ml, may be less than about 300 microliters, less than about 100 microliters, less than about 30 microliters, less than about 10 microliters, less than about 3 microliters, less than about 1 microliter, etc.

Further examples of various embodiments of the invention are illustrated in Figs. 6 and 8. In Fig. 7, device 500 is illustrated. In this example, device 500 includes a housing 501, an adhesive 502 for adhesion of the device to the skin, and a substance

transfer component 503. In this figure, substance transfer component 503 includes a plurality of microneedles 505, although other substance transfer components as discussed herein may also be used. Microneedles 505 are contained within recess 508. Also shown in Fig. 7 is vacuum chamber 513 which, in this example, is self-contained within device 500. Vacuum chamber 513 is in fluidic communication with recess 508 via channel 511, for example, as controlled by a controller or an actuator. Device actuator 560 is shown at the top of device 500. Device actuator 560 may be, for example, a button, switch, slider, dial, etc. and may cause microneedles 505 to move towards the skin when the device is placed on the skin. For example, the microneedles may be moved mechanically (e.g., compression spring, Belleville spring, etc.), electrically (e.g., with the aid of a servo, which may be computer-controlled), pneumatically, etc. In some cases, device actuator 560 (or another actuator) may be used to cause the microneedles to be received from the skin, and/or the microneedles may be received automatically after delivering and/or receiving fluid from the subject, e.g., without any intervention by the subject, or by another person. Non-limiting examples of such techniques are discussed in detail below.

Another example is illustrated with reference to Fig. 8. In this figure, device 500 includes a housing 501, an adhesive 502 for adhesion of the device to the skin, and a substance transfer component 503. In Fig. 8, substance transfer component 503 includes a plurality of microneedles 505 within recess 508, although other substance transfer components as discussed herein may also be used. Device actuator 560 is shown at the top of device 500. Device actuator 560 may be, for example, a button, switch, slider, dial, etc. and may cause microneedles 505 to move towards the skin when the device is placed on the skin. For example, the microneedles may be moved mechanically (e.g., compression spring, Belleville spring, etc.), electrically (e.g., with the aid of a servo, which may be computer-controlled), pneumatically, etc., e.g., via component 584 (e.g., a piston, a screw, a mechanical linkage, etc.). In some cases, device actuator 560 may also be able to receive the microneedles from the skin after use, e.g., after a fluid is delivered and/or received from the skin.

Chamber 513, in this figure, is a self-contained vacuum chamber. Vacuum chamber 513 is in fluidic communication with recess 508 via channel 511, for example, as controlled by a controller or an actuator. Also illustrated in Fig. 8 is fluid reservoir

540, which may contain a fluid such as an anticoagulant. The fluid may be introduced into blood or other fluid received from the skin. Controlling fluid flow from fluid reservoir may be one or more suitable fluidic control elements, e.g., pumps, nozzles, valves, or the like, for example, pump 541 in Fig. 8.

5 In certain embodiments, the substance transfer component may be fastened on a deployment actuator. In some cases, the deployment actuator can bring the substance transfer component to the skin, and in certain instances, insert the substance transfer component into the skin. For example, the substance transfer component can be moved mechanically, electrically (e.g., with the aid of a servo, which may be computer-  
10 controlled), pneumatically, via a piston, a screw, a mechanical linkage, or the like. In one set of embodiments, the deployment actuator can insert the substance transfer component into the skin at a speed of at least about 0.1 cm/s, at least about 0.3 cm/s, about 1 cm/s, at least about 3 cm/s, at least about 10 cm/s, at least about 30 cm/s, at least about 1 m/s, at least about 2 m/s, at least about 3 m/s, at least about 4 m/s, at least about  
15 5 m/s, at least about 6 m/s, at least about 7 m/s, at least about 8 m/s, at least about 9 m/s, at least about 10 m/s, at least about 12 m/s, etc., at the point where the substance transfer component initially contacts the skin. Without wishing to be bound by any theory, it is believed that relatively faster insertion speeds may increase the ability of the substance transfer component to penetrate the skin (without deforming the skin or causing the skin  
20 to move in response), and/or decrease the amount of pain felt by the application of the substance transfer component to the skin. Any suitable method of controlling the penetration speed into the skin may be used, include those described herein.

As mentioned, in some embodiments, blood or other bodily fluids may be stored within the device for later use and/or analysis. For example, the device may be attached  
25 to a suitable external apparatus able to analyze a portion of the device (e.g., containing the fluid), and/or the external apparatus may remove at least some of the blood or other fluid from the device for subsequent analysis and/or storage. In some cases, however, at least some analysis may be performed by the device itself, e.g., using one or more sensors, etc., contained within the device.

30 For example, as discussed in detail below, in some cases, a storage chamber may contain a reagent or a reaction entity able to react with an analyte suspected of being present in the blood (or other fluid) entering the device, and in some cases, the reaction



entity may be determined to determine the analyte. In some cases, the determination may be made externally of the device, e.g., by determining a color change or a change in fluorescence, etc. The determination may be made by a person, or by an external apparatus able to analyze at least a portion of the device. In some cases, the  
5 determination may be made without removing blood from the device, e.g., from the storage chamber. (In other cases, however, blood or other fluid may first be removed from the device before being analyzed.) For example, the device may include one or more sensors (e.g., ion sensors such as  $K^+$  sensors, colorimetric sensors, fluorescence sensors, etc.), and/or contain “windows” that allow light to penetrate the device. The  
10 windows may be formed of glass, plastic, etc., and may be selected to be at least partially transparent to one or a range of suitable wavelengths, depending on the analyte or condition to be determined. As a specific example, the entire device (or a portion thereof) may be mounted in an external apparatus, and light from the external apparatus may pass through or otherwise interact with at least a portion of the device (e.g., be  
15 reflected or refracted via the device) to determine the analyte and/or the reaction entity.

In one aspect, the device may be interfaced with an external apparatus able to determine an analyte contained within a fluid in the device, for example within a storage chamber as discussed herein. For example, the device may be mounted on an external holder, the device may include a port for transporting fluid out of the device, the device  
20 may include a window for interrogating a fluid contained within the device, or the like. Examples may be seen in U.S. Patent Application Serial No. 13/006,165 filed on January 13, 2011, entitled “Sampling Device Interfaces,” incorporated herein by reference in its entirety.

Thus, the device, in certain embodiments, may contain a portion able to  
25 determine a fluid received from the skin. For example, a portion of the device may contain a sensor, or reagents able to interact with an analyte contained or suspected to be present within the received fluid from the subject, for example, a marker for a disease state. The sensor may be embedded within or integrally connected to the device, or positioned remotely but with physical, electrical, and/or optical connection with the  
30 device so as to be able to sense a chamber within or fluid from the device. For example, the sensor may be in fluidic communication with fluid received from a subject, directly, via a microfluidic channel, an analytical chamber, etc. The sensor may be able to sense

an analyte, e.g., one that is suspected of being in a fluid received from a subject. For example, a sensor may be free of any physical connection with the device, but may be positioned so as to detect the results of interaction of electromagnetic radiation, such as infrared, ultraviolet, or visible light, which has been directed toward a portion of the device, e.g., a chamber within the device. As another example, a sensor may be positioned on or within the device, and may sense activity in a chamber by being connected optically to the chamber. Sensing communication can also be provided where the chamber is in communication with a sensor fluidly, optically or visually, thermally, pneumatically, electronically, or the like, so as to be able to sense a condition of the chamber. As one example, the sensor may be positioned downstream of a chamber, within a channel such a microfluidic channel, on an external apparatus, or the like.

Thus, the invention provides, in certain embodiments, sensors able to determine an analyte. Such determination may occur within the skin, and/or externally of the subject, e.g., within a device on the surface of the skin, depending on the embodiment. “Determine,” in this context, generally refers to the analysis of a species, for example, quantitatively or qualitatively, and/or the detection of the presence or absence of the species. “Determining” may also refer to the analysis of an interaction between two or more species, for example, quantitatively or qualitatively, and/or by detecting the presence or absence of the interaction, e.g. determination of the binding between two species. The species may be, for example, a bodily fluid and/or an analyte suspected of being present in the bodily fluid. “Determining” also means detecting or quantifying interaction between species.

Non-limiting examples of sensors include dye-based detection systems, affinity-based detection systems, microfabricated gravimetric analyzers, CCD cameras, optical detectors, optical microscopy systems, electrical systems, thermocouples and thermistors, pressure sensors, etc. Those of ordinary skill in the art will be able to identify other suitable sensors. The sensor can include a colorimetric detection system in some cases, which may be external to the device, or microfabricated into the device in certain cases. As an example of a colorimetric detection system, if a dye or a fluorescent entity is used (e.g. in a particle), the colorimetric detection system may be able to detect a change or shift in the frequency and/or intensity of the dye or fluorescent entity.

Examples of sensors include, but are not limited to, pH sensors, optical sensors, ion sensors, colorimetric sensors, a sensor able to detect the concentration of a substance, or the like, e.g., as discussed herein. For instance, in one set of embodiments, the device may include an ion selective electrode. The ion selective electrode may be able to  
5 determine a specific ion and/or ions such as  $K^+$ ,  $H^+$ ,  $Na^+$ ,  $Ag^+$ ,  $Pb^{2+}$ ,  $Cd^{2+}$ , or the like. Various ion selective electrodes can be obtained commercially. As a non-limiting example, a potassium-selective electrode may include an ion exchange resin membrane, using valinomycin, a potassium channel, as the ion carrier in the membrane to provide potassium specificity.

10 Examples of analytes that the sensor may be used to determine include, but are not limited to, pH or metal ions, proteins, nucleic acids (e.g. DNA, RNA, etc.), drugs, sugars (e.g., glucose), hormones (e.g., estradiol, estrone, progesterone, progestin, testosterone, androstenedione, etc.), carbohydrates, or other analytes of interest. Other conditions that can be determined can include pH changes, which may indicate disease,  
15 yeast infection, periodontal disease at a mucosal surface, oxygen or carbon monoxide levels which indicate lung dysfunction, and drug levels, e.g., legal prescription levels of drugs such as coumadin, other drugs such as nicotine, or illegal such as cocaine. Further examples of analytes include those indicative of disease, such as cancer specific markers such as CEA and PSA, viral and bacterial antigens, and autoimmune indicators such as  
20 antibodies to double stranded DNA, indicative of Lupus. Still other conditions include exposure to elevated carbon monoxide, which could be from an external source or due to sleep apnea, too much heat (important in the case of babies whose internal temperature controls are not fully self-regulating) or from fever. Still other potentially suitable analytes include various pathogens such as bacteria or viruses, and/or markers produced  
25 by such pathogens.

As additional non-limiting examples, the sensor may contain an antibody able to interact with a marker for a disease state, an enzyme such as glucose oxidase or glucose 1-dehydrogenase able to detect glucose, or the like. The analyte may be determined quantitatively or qualitatively, and/or the presence or absence of the analyte within the  
30 received fluid may be determined in some cases. Those of ordinary skill in the art will be aware of many suitable commercially-available sensors, and the specific sensor used may depend on the particular analyte being sensed. For instance, various non-limiting

examples of sensor techniques include pressure or temperature measurements, spectroscopy such as infrared, absorption, fluorescence, UV/visible, FTIR (“Fourier Transform Infrared Spectroscopy”), or Raman; piezoelectric measurements; immunoassays; electrical measurements, electrochemical measurements (e.g., ion-specific electrodes); magnetic measurements, optical measurements such as optical density measurements; circular dichroism; light scattering measurements such as quasioelectric light scattering; polarimetry; refractometry; chemical indicators such as dyes; or turbidity measurements, including nephelometry.

In one set of embodiments, a sensor in the device may be used to determine a condition of the blood present within the device. For example, the sensor may indicate the condition of analytes commonly found within the blood, for example, O<sub>2</sub>, K<sup>+</sup>, hemoglobin, Na<sup>+</sup>, glucose, or the like. As a specific non-limiting example, in some embodiments, the sensor may determine the degree of hemolysis within blood contained within the device. Without wishing to be bound by any theory, it is believed that in some cases, hemolysis of red blood cells may cause the release of potassium ions and/or free hemoglobin into the blood. By determining the levels of potassium ions, and/or hemoglobin (e.g., by subjecting the device and/or the blood to separate cells from plasma, then determining hemoglobin in the plasma using a suitable colorimetric assay), the amount of blood lysis or “stress” experienced by the blood contained within the device may be determined. Accordingly, in one set of embodiments, the device may indicate the usability of the blood (or other fluid) contained within the device, e.g., by indicating the degree of stress or the amount of blood lysis. Other examples of devices suitable for indicating the usability of the blood (or other fluid) contained within the device are also discussed herein (e.g., by indicating the amount of time blood has been contained in the device, the temperature history of the device, etc.).

For instance, fluids received from the subject will often contain various analytes within the body that are important for diagnostic purposes, for example, markers for various disease states, such as glucose (e.g., for diabetics); other example analytes include ions such as sodium, potassium, chloride, calcium, magnesium, and/or bicarbonate (e.g., to determine dehydration); gases such as carbon dioxide or oxygen; H<sup>+</sup> (i.e., pH); metabolites such as urea, blood urea nitrogen or creatinine; hormones such as estradiol, estrone, progesterone, progestin, testosterone, androstenedione, etc. (e.g., to

determine pregnancy, illicit drug use, or the like); or cholesterol. Other examples include insulin, or hormone levels. As discussed herein, certain embodiments of the present invention are generally directed at methods for receiving fluids from the body, and optionally determining one or more analytes within the received fluid. Thus, in  
5 some embodiments, at least a portion of the fluid may be stored, and/or analyzed to determine one or more analytes, e.g., a marker for a disease state, or the like. The fluid received from the skin may be subjected to such uses, and/or one or more materials previously delivered to the skin may be subject to such uses.

Still other potentially suitable analytes include various pathogens such as bacteria  
10 or viruses, and/or markers produced by such pathogens. Thus, in certain embodiments of the invention, as discussed below, one or more analytes within the pooled region of fluid may be determined in some fashion, which may be useful in determining a past, present and/or future condition of the subject.

In some embodiments, the device may be connected to an external apparatus for  
15 determining at least a portion of the device, a fluid removed from the device, an analyte suspected of being present within the fluid, or the like. For example, the device may be connected to an external analytical apparatus, and fluid removed from the device for later analysis, or the fluid may be analyzed within the device *in situ*, e.g., by adding one or more reaction entities to the device, for instance, to a storage chamber, or to analytical  
20 chamber within the device. For example, in one embodiment, the external apparatus may have a port or other suitable surface for mating with a port or other suitable surface on the device, and blood or other fluid can be removed from the device using any suitable technique, e.g., using vacuum or pressure, etc. The blood may be removed by the external apparatus, and optionally, stored and/or analyzed in some fashion. For  
25 example, in one set of embodiments, the device may include an exit port for removing a fluid from the device (e.g., blood). In some embodiments, fluid contained within a storage chamber in the device may be removed from the device, and stored for later use or analyzed outside of the device. In some cases, the exit port may be separate from the substance transfer component. An example is shown with exit port 670 and substance  
30 transfer component 620 in device 600 in Fig. 6. As shown in this figure, the exit port can be in fluidic communication with vacuum chamber 610, which can also serve as a fluid reservoir in some cases.

In one set of embodiments, the device may include an anticoagulant or a stabilizing agent for stabilizing the fluid received from the skin. For example, the fluid may be stored within the device for a certain period of time, and/or the device (or a portion thereof) may be moved or shipped to another location for analysis or later use.

5 For instance, a device may contain anticoagulant or a stabilizing agent in a storage chamber. In some cases, more than one anticoagulant may be used, e.g., in the same storage chamber, or in more than one storage chamber.

As a specific non-limiting example, an anticoagulant may be used for blood received from the skin. Examples of anticoagulants include, but are not limited to,  
10 heparin, citrate, thrombin, oxalate, ethylenediaminetetraacetic acid (EDTA), sodium polyanethol sulfonate, acid citrate dextrose. Other agents may be used in conjunction or instead of anticoagulants, for example, stabilizing agents such as solvents, diluents, buffers, chelating agents, antioxidants, binding agents, preservatives, antimicrobials, or the like. Examples of preservatives include, for example, benzalkonium chloride,  
15 chlorobutanol, parabens, or thimerosal. Non-limiting examples of antioxidants include ascorbic acid, glutathione, lipoic acid, uric acid, carotenes, alpha-tocopherol, ubiquinol, or enzymes such as catalase, superoxide dismutase, or peroxidases. Examples of antimicrobials include, but are not limited to, ethanol or isopropyl alcohol, azides, or the like. Examples of chelating agents include, but are not limited to, ethylene glycol  
20 tetraacetic acid or ethylenediaminetetraacetic acid. Examples of buffers include phosphate buffers such as those known to ordinary skill in the art.

In one set of embodiments, at least a portion of the device may be colored to indicate the anticoagulant(s) contained within the device. In some cases, the colors used may be identical or equivalent to that commercially used for Vacutainers<sup>TM</sup>,  
25 Vacuettes<sup>TM</sup>, or other commercially-available phlebotomy equipment. For example, lavender and/or purple may indicate ethylenediaminetetraacetic acid, light blue may indicate citrate, dark blue may indicate ethylenediaminetetraacetic acid, green may indicate heparin, gray may indicate a fluoride and/or an oxalate, orange may indicate a thrombin, yellow may indicate sodium polyanethol sulfonate and/or acid citrate dextrose,  
30 black may indicate citrate, brown may indicate heparin, etc. In other embodiments, however, other coloring systems may be used.

Other coloring systems may be used in other embodiments of the invention, not necessarily indicative of anti-coagulants. For example, in one set of embodiments, the device carries a color indicative of a recommended bodily use site for the device, e.g., a first color indicative of a device suitable for placement on the back, a second color  
5 indicative of a device suitable for placement on a leg, a third color indicative of a device suitable for placement on the arm, etc.

As mentioned, in one set of embodiments, a device of the invention as discussed herein may be shipped to another location for analysis. In some cases, the device may include an anticoagulant or a stabilizing agent contained within the device, e.g., within a  
10 storage chamber for the fluid. Thus, for example, fluid such as blood received from the skin may be delivered to a chamber (e.g., a storage chamber) within the device, then the device, or a portion of the device (e.g., a module) may be shipped to another location for analysis. Any form of shipping may be used, e.g., via mail.

Non-limiting examples of various devices of the invention are shown in Fig. 1.  
15 In Fig. 1A, device 90 is used for receiving a fluid from a subject when the device is placed on the skin of a subject. Device 90 includes sensor 95 and substance transfer component 92, e.g., including a needle, a microneedle, etc., as discussed herein. In fluidic communication with substance transfer component 92 via fluidic channel 99 is sensing chamber 97. In one embodiment, sensing chamber 97 may contain agents such  
20 as particles, enzymes, dyes, etc., for analyzing bodily fluids, such as interstitial fluid or blood. In some cases, fluid may be received using substance transfer component 92 by a vacuum, for example, a self-contained vacuum contained within device 90. Optionally, device 90 also contains a display 94 and associated electronics 93, batteries or other power supplies, etc., which may be used to display sensor readings obtained via sensor  
25 95. In addition, device 90 may also optionally contain memory 98, transmitters for transmitting a signal indicative of sensor 95 to a receiver, etc.

In the example shown in Fig. 1A, device 90 may contain a vacuum source (not shown) that is self-contained within device 90, although in other embodiments, the vacuum source may be external to device 90. (In still other instances, other systems may  
30 be used to deliver and/or receive fluid from the skin, as is discussed herein.) In one embodiment, after being placed on the skin of a subject, the skin may be drawn upward into a recess of the substance transfer component 92, for example, upon exposure to the

vacuum source. Access to the vacuum source may be controlled by any suitable method, e.g., by piercing a seal or a septum; by opening a valve or moving a gate, etc. For instance, upon activation of device 90, e.g., by the subject, remotely, automatically, etc., the vacuum source may be put into fluidic communication with the recess such that skin  
5 is drawn into the recess due to the vacuum. Skin drawn into the recess may come into contact with a skin insertion object (e.g., solid or hollow needles), which may, in some cases, pierce the skin and allow a fluid to be delivered and/or received from the skin. In another embodiment, a skin insertion object may be actuated and moved downward to come into contact with the skin, and optionally retracted after use.

10 Another non-limiting example of a device is shown in Fig. 1B. This figure illustrates a device useful for delivering a fluid to the subject. Device 90 in this figure includes substance transfer component 92, e.g., including a needle, a microneedle, etc., as discussed herein. In fluidic communication with substance transfer component 92 via  
15 fluidic channel 99 is chamber 97, which may contain a drug or other agent to be delivered to the subject. In some cases, fluid may be delivered with a pressure controller, and/or received using substance transfer component 92 by a vacuum, for example, a self-contained vacuum contained within device 90. For instance, upon creating a vacuum, skin may be drawn up towards substance transfer component 92, and the substance transfer component 92 may pierce the skin. Fluid from chamber 97 can  
20 then be delivered into the skin through fluid channel 99 and substance transfer component 92. Optionally, device 90 also contains a display 94 and associated electronics 93, batteries or other power supplies, etc., which may be used control delivery of fluid to the skin. In addition, device 90 may also optionally contain memory 98, transmitters for transmitting a signal indicative of device 90 or fluid delivery to a  
25 receiver, etc.

Yet another non-limiting example of a device of the invention is shown in Fig. 2. Fig. 2A illustrates a view of the device (with the cover removed), while Fig. 2B schematically illustrates the device in cross-section. In Fig. 2B, device 50 includes a  
30 needle 52 contained within a recess 55. Needle 52 may be solid or hollow, depending on the embodiment. Device 50 also includes a self-contained vacuum chamber 60, which wraps around the central portion of the device where needle 52 and recess 55 are located. A channel 62 connects vacuum chamber 60 with recess 55, separated by a foil or a



membrane 67. Also shown in device 50 is button 58. When pushed, button 58 breaks foil 67, thereby connecting vacuum chamber 50 with recess 55, creating a vacuum in recess 55. The vacuum may be used, for example, to draw skin into recess 55, preferably such that it contacts needle 52 and pierces the surface, thereby gaining access to an  
5 internal fluid. The fluid may be controlled, for example, by controlling the size of needle 52, and thereby the depth of penetration. For example, the penetration may be limited to the epidermis, e.g., to collect interstitial fluid, or to the dermis, e.g., to collect blood. In some cases, the vacuum may also be used to at least partially secure device 50 on the surface of the skin, and/or to assist in the receiving of fluid from the skin. For instance,  
10 fluid may flow into channel 62 under action of the vacuum, and optionally to sensor 61, e.g., for detection of an analyte contained within the fluid. For instance, sensor 61 may produce a color change if an analyte is present, or otherwise produce a detectable signal.

Other components may be added to the example of the device illustrated in Fig. 2, in some embodiments of the invention. For example, device 50 may contain a cover,  
15 displays, ports, transmitters, sensors, channels such as microfluidic channels, chambers, and/or various electronics, e.g., to control or monitor fluid transport into or out of device 50, to determine an analyte present within a fluid delivered and/or received from the skin, to determine the status of the device, to report or transmit information regarding the device and/or analytes, or the like, as is discussed in more detail herein. As another  
20 example, device 50 may contain an adhesive, e.g., on surface 54, for adhesion of the device to the skin.

Yet another non-limiting example is illustrated with reference to Fig. 2C. In this example, device 500 includes a housing 501, and an associated substance transfer component 503. Substance transfer component 503 includes a plurality of needles or  
25 microneedles 505, although other skin insertion objects or flow activators as discussed herein may also be used. Also shown in Fig. 5 is sensor 510, connected via channels 511 to recess 508 containing needles or microneedles 505. Chamber 513 may be a self-contained vacuum chamber, and chamber 513 may be in fluidic communication with recess 508 via channel 511, for example, as controlled by a controller or an actuator (not  
30 shown). In this figure, device 500 also contains display 525, which is connected to sensor 510 via electrical connection 522. As an example of use of device 500, when fluid is drawn from the skin (e.g., blood, interstitial fluid, etc.), the fluid may flow

through channel 511 to be determined by sensor 510, e.g., due to action of the vacuum from vacuum chamber 513. In some cases, the vacuum is used, for example, to draw skin into recess 508, preferably such that it contacts needles or microneedles 505 and pierces the surface of the skin to gain access to a fluid internal of the subject, such as  
5 blood or interstitial fluid, etc. The fluid may be controlled, for example, by controlling the size of needle 505, and thereby the depth of penetration. For example, the penetration may be limited to the epidermis, e.g., to collect interstitial fluid, or to the dermis, e.g., to collect blood. Upon determination of the fluid and/or an analyte present or suspected to be present within the fluid, a microprocessor or other controller may  
10 display on display 525 a suitable signal. As is discussed below, a display is shown in this figure by way of example only; in other embodiments, no display may be present, or other signals may be used, for example, lights, smell, sound, feel, taste, or the like.

In some cases, more than one substance transfer component may be present within the device. For instance, the device may be able to be used repeatedly, and/or the  
15 device may be able to deliver and/or receive fluid at more than one location on a subject, e.g., sequentially and/or simultaneously. In some cases, the device may be able to simultaneously deliver and receive fluid to and from a subject. A non-limiting example of a device having more than one substance transfer component is illustrated with reference to Fig. 2E. In this example, device 500 contains a plurality of structures such  
20 as those described herein for delivering and/or receiving fluid from a subject. For example, device 500 in this example contains 3 such units, although any number of units are possible in other embodiments. In this example, device 500 contains three such substance transfer components 575. Each of these substance transfer components may independently have the same or different structures, depending on the particular  
25 application, and they may have structures such as those described herein.

In some embodiments, the device may be an electrical and/or a mechanical device applicable or affixable to the surface of the skin, e.g., using adhesive, or other techniques such as those described herein. The adhesive may be permanent or  
30 temporary, and may be used to affix the device to the surface of the skin. The adhesive may be any suitable adhesive, for example, a pressure sensitive adhesive, a contact adhesive, a permanent adhesive, a hydrogel, a cyanoacrylate, a glue, a gum, hot melts, an

epoxy, or the like. In some cases, the adhesive is chosen to be biocompatible or hypoallergenic.

In another set of embodiments, the device may be mechanically held to the skin, for example, the device may include mechanical elements such as straps, belts, buckles, strings, ties, elastic bands, or the like. For example, a strap may be worn around the device to hold the device in place against the skin of the subject. In yet another set of embodiments, a combination of these and/or other techniques may be used. As one non-limiting example, the device may be affixed to a subject's arm or leg using adhesive and a strap.

As another example, the device may be a handheld device that is applied to the surface of the skin of a subject. In some cases, however, the device may be sufficiently small or portable that the subject can self-administer the device. In certain embodiments, the device may also be powered. In some instances, the device may be applied to the surface of the skin, and is not inserted into the skin. In other embodiments, however, at least a portion of the device may be inserted into the skin, for example, mechanically. For example, in one embodiment, the device may include a cutter, such as a hypodermic needle, a knife blade, a piercing element (e.g., a solid or hollow needle), or the like, as discussed herein.

Any or all of the arrangements described herein can be provided proximate a subject, for example on or proximate a subject's skin. Activation of the devices can be carried out in a variety of ways. In one embodiment, a device can be applied to a subject and a region of the device activated (e.g., pushed, pressed, or tapped by a user) to inject a needle or a microneedle so as to access interstitial fluid. The same or a different tapping or pushing action can activate a vacuum source, open and/or close one or more of a variety of valves, or the like. The device can be a simple one in which it is applied to the skin and operates automatically (where e.g., application to the skin accesses interstitial fluid and draws interstitial fluid into an analysis region) or the device can be applied to the skin and one tapping or other activation can cause fluid to flow through administration of a needle or a microneedle, opening of a valve, activation of vacuum, or any combination. Any number of activation protocols can be carried out by a user repeatedly pushing or tapping a location or selectively, sequentially, and/or periodically activating a variety of switches. In another arrangement, activation of needles or

microneedles, creation of suction blisters, opening and/or closing of valves, and other techniques to facilitate one or more analysis can be carried out electronically or in other manners facilitated by the subject or by an outside controlling entity. For example, a device or patch can be provided proximate a subject's skin and a radio frequency, electromagnetic, or other signal can be provided by a nearby controller or a distant source to activate any of the needles, blister devices, valves or other components of the devices described so that any assay or assays can be carried out as desired.

In some embodiments, fluid may be delivered to the subject, and such fluids may contain materials useful for delivery, e.g., forming at least a portion of the fluid, dissolved within the fluid, carried by the fluid (e.g., suspended or dispersed), or the like. Examples of suitable materials include, but are not limited to, particles such as microparticles or nanoparticles, a chemical, a drug or a therapeutic agent, a diagnostic agent, a carrier, or the like.

As used herein, the term "fluid" generally refers to a substance that tends to flow and to conform to the outline of its container. Typically, fluids are materials that are unable to withstand a static shear stress, and when a shear stress is applied, the fluid experiences a continuing and permanent distortion. The fluid may have any suitable viscosity that permits at least some flow of the fluid. Non-limiting examples of fluids include liquids and gases, but may also include free-flowing solid particles, viscoelastic fluids, and the like. For example, the fluid may include a flowable matrix or a gel, e.g., formed from biodegradable and/or biocompatible material such as polylactic acid, polyglycolic acid, poly(lactic-co-glycolic acid), etc., or other similar materials.

In some cases, fluids or other materials delivered to the subject may be used for indication of a past, present and/or future condition of the subject. Thus, the condition of the subject to be determined may be one that is currently existing in the subject, and/or one that is not currently existing, but the subject is susceptible or otherwise is at an increased risk to that condition. The condition may be a medical condition, e.g., diabetes or cancer, or other physiological conditions, such as dehydration, pregnancy, illicit drug use, or the like. In one set of embodiments, the materials may include a diagnostic agent, for example, one which can determine an analyte within the subject, e.g., one that is a marker for a disease state. As a specific non-limiting example, material delivered to the

skin, e.g., to the dermis or epidermis, to a pooled region of fluid, etc., of a subject may include a particle including an antibody directed at a marker produced by bacteria.

In other cases, however, the materials delivered to the subject may be used to determine conditions that are external to the subject. For example, the materials may contain reaction entities able to recognize pathogens or other environmental conditions surrounding the subject, for example, an antibody able to recognize an external pathogen (or pathogen marker). As a specific example, the pathogen may be anthrax and the antibody may be an antibody to anthrax spores. As another example, the pathogen may be a *Plasmodia* (some species of which causes malaria) and the antibody may be an antibody that recognizes the *Plasmodia*.

According to one aspect of the invention, the device is of a relatively small size. In some embodiments, the device may be sized such that it is wearable and/or carryable by a subject. For example, the device may be self-contained, needing no wires, cables, tubes, external structural elements, or other external support. The device may be positioned on any suitable position of the subject, for example, on the arm or leg, on the back, on the abdomen, etc. As mentioned, in some embodiments, the device may be affixed or held onto the surface of the skin using any suitable technique, e.g., using adhesives, mechanical elements such as straps, belts, buckles, strings, ties, elastic bands, or the like. In some cases, the device may be positioned on the subject such that the subject is able to move around (e.g., walking, exercising, typing, writing, drinking or eating, using the bathroom, etc.) while wearing the device. For example, the device may have a mass and/or dimensions such that the subject is able to wear the device for at least about 5 minutes, and in some cases for longer periods of time, e.g., at least about 10 minutes, at least about 15 minutes, at least about 30 minutes, at least about 45 minutes, at least about 1 hour, at least about 3 hours, at least 5 hours, at least about 8 hours, at least about 1 day, at least about 2 days, at least about 4 days, at least about 1 week, at least about 2 weeks, at least about 4 weeks, etc.

In some embodiments, the device is relatively lightweight. For example, the device may have a mass of no more than about 1 kg, no more than about 300 g, no more than about 150 g, no more than about 100 g, no more than about 50 g, no more than about 30 g, no more than about 25 g, no more than about 20 g, no more than about 10 g, no more than about 5 g, or no more than about 2 g. For instance, in various

embodiments, the device has a mass of between about 2 g and about 25 g, a mass of between about 2 g and about 10 g, a mass of between 10 g and about 50 g, a mass of between about 30 g and about 150 g, etc.

The device, in some cases, may be relatively small. For example, the device may  
5 be constructed and arranged to lie relatively close to the skin. Thus, for instance, the device may have a largest vertical dimension, extending from the skin of the subject when the device is positioned on the skin, of no more than about 25 cm, no more than about 10 cm, no more than about 7 cm, no more than about 5 cm, no more than about 3 cm, no more than about 2 cm, no more than about 1 cm, no more than about 8 mm, no  
10 more than about 5 mm, no more than about 3 mm, no more than about 2 mm, no more than about 1 mm, or no more than about 0.5 mm. In some cases, the device may have a largest vertical dimension of between about 0.5 cm and about 1 cm, between about 2 and about 3 cm, between about 2.5 cm and about 5 cm, between about 2 cm and about 7 cm, between about 0.5 mm and about 7 cm, etc.

15 In another set of embodiments, the device may have a relatively small size. For example, the device may have a largest lateral dimension (e.g., parallel to the skin) of no more than about 25 cm, no more than about 10 cm, no more than about 7 cm, no more than about 5 cm, no more than about 3 cm, no more than about 2 cm, or no more than about 1 cm. In some cases, the device may have a largest lateral dimension of between  
20 about 0.5 cm and about 1 cm, between about 2 and about 3 cm, between about 2.5 cm and about 5 cm, between about 2 cm and about 7 cm, etc.

Combinations of these and/or other dimensions are also possible in other embodiments. As non-limiting examples, the device may have a largest lateral dimension of no more than about 5 cm, a largest vertical dimension of no more than  
25 about 1 cm, and a mass of no more than about 25 g; or the device may have a largest lateral dimension of no more than about 5 cm, a largest vertical dimension of no more than about 1 cm, and a mass of no more than about 25 g; etc.

In certain embodiments, the may also include a device actuator. The device actuator may be constructed and arranged to cause exposure of the substance transfer  
30 component to the skin upon actuation of the device actuator. For example, the activator may cause the substance transfer component to release a chemical to contact the skin, a microneedle or other substance transfer component to be driven into the skin, a vacuum

to be applied to the skin, a jet of fluid to be directed to the skin, or the like. The device actuator may be actuated by the subject, and/or by another person (e.g., a health care provider), or the device itself may be self-actuating, e.g., upon application to the skin of a subject. The actuator may be actuated once, or multiple times in some cases.

5           The device may be actuated, for example, by pushing a button, pressing a switch, moving a slider, turning a dial, or the like. The subject, and/or another person, may actuate the actuator. In some cases, the device may be remotely actuated. For example, a health care provider may send an electromagnetic signal which is received by the device in order to activate the device, e.g., a wireless signal, a radio signal, etc.

10           In one set of embodiments, the device may include channels such as microfluidic channels, which may be used to deliver and/or receive fluids and/or other materials into or out of the skin, e.g., within the pooled region of fluid. In some cases, the microfluidic channels are in fluid communication with a substance transfer component that is used to deliver and/or receive fluids to or from the skin. For example, in one set of  
15           embodiments, the device may include a hypodermic needle that can be inserted into the skin, and fluid may be delivered into the skin via the needle and/or received from the skin via the needle. The device may also include one or more microfluidic channels to contain fluid for delivery to the needle, e.g., from a source of fluid, and/or to receive fluid from the skin, e.g., for delivery to an analytical chamber within the device, to a  
20           reservoir for later analysis, or the like.

          In some cases, more than one chamber may be present within the device, and in some cases, some or all of the chambers may be in fluidic communication, e.g., via channels such as microfluidic channels. In various embodiments, a variety of chambers and/or channels may be present within the device, depending on the application. For  
25           example, the device may contain chambers for sensing an analyte, chambers for holding reagents, chambers for controlling temperature, chambers for controlling pH or other conditions, chambers for creating or buffering pressure or vacuum, chambers for controlling or dampening fluid flow, mixing chambers, or the like.

          Thus, in one set of embodiments, the device may include a microfluidic channel.  
30           As used herein, “microfluidic,” “microscopic,” “microscale,” the “micro-” prefix (for example, as in “microchannel”), and the like generally refers to elements or articles having widths or diameters of less than about 1 mm, and less than about 100 microns

(micrometers) in some cases. In some embodiments, larger channels may be used instead of, or in conjunction with, microfluidic channels for any of the embodiments discussed herein. For example, channels having widths or diameters of less than about 10 mm, less than about 9 mm, less than about 8 mm, less than about 7 mm, less than about 6 mm, less than about 5 mm, less than about 4 mm, less than about 3 mm, or less than about 2 mm may be used in certain instances. In some cases, the element or article includes a channel through which a fluid can flow. In all embodiments, specified widths can be a smallest width (i.e. a width as specified where, at that location, the article can have a larger width in a different dimension), or a largest width (i.e. where, at that location, the article has a width that is no wider than as specified, but can have a length that is greater). Thus, for instance, the microfluidic channel may have an average cross-sectional dimension (e.g., perpendicular to the direction of flow of fluid in the microfluidic channel) of less than about 1 mm, less than about 500 microns, less than about 300 microns, or less than about 100 microns. In some cases, the microfluidic channel may have an average diameter of less than about 60 microns, less than about 50 microns, less than about 40 microns, less than about 30 microns, less than about 25 microns, less than about 10 microns, less than about 5 microns, less than about 3 microns, or less than about 1 micron.

A “channel,” as used herein, means a feature on or in an article (e.g., a substrate) that at least partially directs the flow of a fluid. In some cases, the channel may be formed, at least in part, by a single component, e.g. an etched substrate or molded unit. The channel can have any cross-sectional shape, for example, circular, oval, triangular, irregular, square or rectangular (having any aspect ratio), or the like, and can be covered or uncovered (i.e., open to the external environment surrounding the channel). In embodiments where the channel is completely covered, at least one portion of the channel can have a cross-section that is completely enclosed, and/or the entire channel may be completely enclosed along its entire length with the exception of its inlet and outlet.

A channel may have any aspect ratio, e.g., an aspect ratio (length to average cross-sectional dimension) of at least about 2:1, more typically at least about 3:1, at least about 5:1, at least about 10:1, etc. As used herein, a “cross-sectional dimension,” in reference to a fluidic or microfluidic channel, is measured in a direction generally



perpendicular to fluid flow within the channel. A channel generally will include characteristics that facilitate control over fluid transport, e.g., structural characteristics and/or physical or chemical characteristics (hydrophobicity vs. hydrophilicity) and/or other characteristics that can exert a force (e.g., a containing force) on a fluid. The fluid  
5 within the channel may partially or completely fill the channel. In some cases the fluid may be held or confined within the channel or a portion of the channel in some fashion, for example, using surface tension (e.g., such that the fluid is held within the channel within a meniscus, such as a concave or convex meniscus). In an article or substrate, some (or all) of the channels may be of a particular size or less, for example, having a  
10 largest dimension perpendicular to fluid flow of less than about 5 mm, less than about 2 mm, less than about 1 mm, less than about 500 microns, less than about 200 microns, less than about 100 microns, less than about 60 microns, less than about 50 microns, less than about 40 microns, less than about 30 microns, less than about 25 microns, less than about 10 microns, less than about 3 microns, less than about 1 micron, less than about  
15 300 nm, less than about 100 nm, less than about 30 nm, or less than about 10 nm or less in some cases. In one embodiment, the channel is a capillary.

In some cases, the device may contain one or more chambers or reservoirs for holding fluid. In some cases, the chambers may be in fluidic communication with one or more substance transfer components and/or one or more microfluidic channels. For  
20 instance, the device may contain a chamber for collecting fluid received from a subject (e.g., for storage and/or later analysis), a chamber for containing a fluid for delivery to the subject (e.g., blood, saline, optionally containing drugs, hormones, vitamins, pharmaceutical agents, or the like), etc.

After receipt of the fluid into the device, the device, or a portion thereof, may be  
25 removed from the skin of the subject, e.g., by the subject or by another person. For example, the entire device may be removed, or a portion of the device containing the storage reservoir may be removed from the device, and optionally replaced with another storage reservoir. Thus, for instance, in one embodiment, the device may contain two or more modules, for example, a first module that is able to cause receiving of fluid from  
30 the skin into a storage reservoir, and a second module containing the storage module. In some cases, the module containing the storage reservoir may be removed from the device. Other examples of modules and modular systems are discussed below; other

examples are discussed in U.S. Provisional Patent Application Serial No. 61/256,931, filed October 30, 2009, entitled "Modular Systems for Application to the Skin," incorporated by reference herein in its entirety.

The received fluid may then be sent to a clinical and/or laboratory setting, e.g.,  
5 for analysis. In some embodiments, the entire device may be sent to the clinical and/or laboratory setting; in other embodiments, however, only a portion of the device (e.g., a module containing a storage reservoir containing the fluid) may be sent to the clinical and/or laboratory setting. In some cases, the fluid may be shipped using any suitable technique (e.g., by mail, by hand, etc.). In certain instances, the subject may give the  
10 fluid to appropriate personnel at a clinical visit. For instance, a doctor may prescribe a device as discussed above for use by the subject, and at the next doctor visit, the subject may give the doctor the received fluid, e.g., contained within a device or module.

In some aspects, the device may contain an indicator. The indicator may be used for determining a condition of a fluid contained within the device, e.g., within a fluid  
15 storage chamber or a fluid reservoir. In some embodiments, the indicator may indicate one or more conditions associated with the introduction of fluid into the storage component and/or one or more conditions associated with storage of fluid in the storage component. For example, the indicator may indicate the condition of blood or ISF within the device, e.g., as the device is being transported or shipped to a clinical or a  
20 laboratory setting. The indicator may indicate the condition of the blood through any suitable technique, e.g., visually (such as with a color change), using a display, by producing a sound, etc. For instance, the indicator may have a display that is green if the fluid has not been exposed to certain temperatures or if there is no adverse chemical reaction present within the fluid (e.g., a change in pH, growth of microorganisms, etc.),  
25 but is yellow or red if adverse conditions are or have been present (e.g., exposure to temperatures that are too extreme, growth of microorganisms, etc.). In other embodiments, the display may display a visual message, a sound may be produced by the device, or the like.

In some cases, the indicator may be activated upon the accessing of fluid by the  
30 access component and/or introduction of fluid into the storage component. In one set of embodiments, the indicator may be activated upon the introduction of fluid within a fluid

storage reservoir, upon activation of the device (e.g., to receive fluid from a subject, as discussed below), upon activation by a user (e.g., by the subject, or another person), etc.

In some cases, the indicator may determine the condition of fluid within a fluid storage reservoir within the device using one or more suitable sensors, for example, pH  
5 sensors, temperature sensors (e.g., thermocouples), oxygen sensors, or the like. For instance, a sensor may be present within or proximate the fluid storage reservoir for determining the temperature of the fluid within the fluid storage reservoir. In some cases, for example, more than one sensor measurement may be taken, e.g., at multiple points of time or even continuously. In some cases, the indicator may also record the  
10 sensor determinations, e.g., for analysis or later study.

In certain embodiments, time information may be determined and/or recorded by the indicator. For example, the time fluid enters a fluid storage reservoir may be recorded, e.g., using a time/date stamp (e.g., absolute time), and/or using the duration of time that fluid has been present within the fluid storage reservoir. The time information  
15 may also be recorded in some embodiments.

As discussed, in one set of embodiments, information from sensors and/or time information may be used to determine a condition of the fluid within the fluid storage reservoir. For example, if certain limits are met or exceeded, the indicator may indicate that, as discussed above. As a specific non-limiting example, if the temperature of the  
20 device is too low (e.g., reaches 0 °C) or too high (e.g., reaches 100 °C or 37 °C), this may be displayed by a display on the indicator. Thus, fluid exposed to temperature extremes may be identified, e.g., as being problematic or spoiled. As a another non-limiting example, it may be desired to keep the pH of fluid within the device within certain conditions, and if the pH is exceeded (e.g., too acidic or too basic), this may be displayed  
25 by a display on the indicator, for example, if the pH is less than 6 or 5, or greater than 8 or 9. In some cases, the time that fluid is present within the device may be kept within certain limits as well, as another condition. For example, the indicator may indicate that fluid has been present within the device for more than about 12 hours, more than about 18 hours, or more than about 24 hours, which may indicate the fluid as being  
30 problematic, spoiled, etc.

In one set of embodiments, conditions such as these may also be combined (e.g., time and temperature). Thus, for example, fluid exposed to a first temperature may be

allowed to be present within the device for a first time, while fluid exposed to a second temperature may be allowed to be present within the device for a second time, before the indicator displays this.

In some embodiments, the indicator may record and/or transmit sensor or time  
5 information. This may be recorded and/or transmitted using any suitable format. For instance, the information may be transmitted using a wireless signal, a radio signal, etc., or recorded on any suitable electronic media, e.g., on a microchip, flash drive, optically, magnetically, etc.

A variety of materials and methods, according to certain aspects of the invention,  
10 can be used to form the device, e.g., microfluidic channels, chambers, etc. For example, various components of the invention can be formed from solid materials, in which the channels can be formed via micromachining, film deposition processes such as spin coating and chemical vapor deposition, laser fabrication, photolithographic techniques, etching methods including wet chemical or plasma processes, and the like. See, for  
15 example, *Scientific American*, 248:44-55, 1983 (Angell, *et al*).

In one set of embodiments, various components of the systems and devices of the invention can be formed of a polymer, for example, an elastomeric polymer such as polydimethylsiloxane ("PDMS"), polytetrafluoroethylene ("PTFE" or Teflon<sup>®</sup>), or the like. For instance, according to one embodiment, a microfluidic channel may be  
20 implemented by fabricating the fluidic system separately using PDMS or other soft lithography techniques (details of soft lithography techniques suitable for this embodiment are discussed in the references entitled "Soft Lithography," by Younan Xia and George M. Whitesides, published in the *Annual Review of Material Science*, 1998, Vol. 28, pages 153-184, and "Soft Lithography in Biology and Biochemistry," by  
25 George M. Whitesides, Emanuele Ostuni, Shuichi Takayama, Xingyu Jiang and Donald E. Ingber, published in the *Annual Review of Biomedical Engineering*, 2001, Vol. 3, pages 335-373; each of these references is incorporated herein by reference).

Other examples of potentially suitable polymers include, but are not limited to, polyethylene terephthalate (PET), polyacrylate, polymethacrylate, polycarbonate,  
30 polystyrene, polyethylene, polypropylene, polyvinylchloride, cyclic olefin copolymer (COC), polytetrafluoroethylene, a fluorinated polymer, a silicone such as polydimethylsiloxane, polyvinylidene chloride, bis-benzocyclobutene ("BCB"), a

polyimide, a fluorinated derivative of a polyimide, or the like. Combinations, copolymers, or blends involving polymers including those described above are also envisioned. The device may also be formed from composite materials, for example, a composite of a polymer and a semiconductor material.

5           In some embodiments, various components of the invention are fabricated from polymeric and/or flexible and/or elastomeric materials, and can be conveniently formed of a hardenable fluid, facilitating fabrication via molding (e.g. replica molding, injection molding, cast molding, etc.). The hardenable fluid can be essentially any fluid that can be induced to solidify, or that spontaneously solidifies, into a solid capable of containing  
10 and/or transporting fluids contemplated for use in and with the fluidic network. In one embodiment, the hardenable fluid comprises a polymeric liquid or a liquid polymeric precursor (i.e. a “prepolymer”). Suitable polymeric liquids can include, for example, thermoplastic polymers, thermoset polymers, waxes, metals, or mixtures or composites thereof heated above their melting point. As another example, a suitable polymeric  
15 liquid may include a solution of one or more polymers in a suitable solvent, which solution forms a solid polymeric material upon removal of the solvent, for example, by evaporation. Such polymeric materials, which can be solidified from, for example, a melt state or by solvent evaporation, are well known to those of ordinary skill in the art. A variety of polymeric materials, many of which are elastomeric, are suitable, and are  
20 also suitable for forming molds or mold masters, for embodiments where one or both of the mold masters is composed of an elastomeric material. A non-limiting list of examples of such polymers includes polymers of the general classes of silicone polymers, epoxy polymers, and acrylate polymers. Epoxy polymers are characterized by the presence of a three-membered cyclic ether group commonly referred to as an epoxy  
25 group, 1,2-epoxide, or oxirane. For example, diglycidyl ethers of bisphenol A can be used, in addition to compounds based on aromatic amine, triazine, and cycloaliphatic backbones. Another example includes the well-known Novolac polymers. Non-limiting examples of silicone elastomers suitable for use according to the invention include those formed from precursors including the chlorosilanes such as methylchlorosilanes,  
30 ethylchlorosilanes, phenylchlorosilanes, etc.

Silicone polymers are used in certain embodiments, for example, the silicone elastomer polydimethylsiloxane. Non-limiting examples of PDMS polymers include

those sold under the trademark Sylgard by Dow Chemical Co., Midland, MI, and particularly Sylgard 182, Sylgard 184, and Sylgard 186. Silicone polymers including PDMS have several beneficial properties simplifying fabrication of the microfluidic structures of the invention. For instance, such materials are inexpensive, readily  
5 available, and can be solidified from a prepolymeric liquid via curing with heat. For example, PDMSs are typically curable by exposure of the prepolymeric liquid to temperatures of about, for example, about 65 °C to about 75 °C for exposure times of, for example, about an hour. Also, silicone polymers, such as PDMS, can be elastomeric and thus may be useful for forming very small features with relatively high aspect ratios,  
10 necessary in certain embodiments of the invention. Flexible (e.g., elastomeric) molds or masters can be advantageous in this regard.

One advantage of forming structures such as microfluidic structures of the invention from silicone polymers, such as PDMS, is the ability of such polymers to be oxidized, for example by exposure to an oxygen-containing plasma such as an air  
15 plasma, so that the oxidized structures contain, at their surface, chemical groups capable of cross-linking to other oxidized silicone polymer surfaces or to the oxidized surfaces of a variety of other polymeric and non-polymeric materials. Thus, components can be fabricated and then oxidized and essentially irreversibly sealed to other silicone polymer surfaces, or to the surfaces of other substrates reactive with the oxidized silicone polymer  
20 surfaces, without the need for separate adhesives or other sealing means. In most cases, sealing can be completed simply by contacting an oxidized silicone surface to another surface without the need to apply auxiliary pressure to form the seal. That is, the pre-oxidized silicone surface acts as a contact adhesive against suitable mating surfaces. Specifically, in addition to being irreversibly sealable to itself, oxidized silicone such as  
25 oxidized PDMS can also be sealed irreversibly to a range of oxidized materials other than itself including, for example, glass, silicon, silicon oxide, quartz, silicon nitride, polyethylene, polystyrene, glassy carbon, and epoxy polymers, which have been oxidized in a similar fashion to the PDMS surface (for example, via exposure to an oxygen-containing plasma). Oxidation and sealing methods useful in the context of the  
30 present invention, as well as overall molding techniques, are described in the art, for example, in an article entitled "Rapid Prototyping of Microfluidic Systems and

Polydimethylsiloxane,” *Anal. Chem.*, 70:474-480, 1998 (Duffy *et al.*), incorporated herein by reference.

Another advantage to forming microfluidic structures of the invention (or interior, fluid-contacting surfaces) from oxidized silicone polymers is that these surfaces  
5 can be much more hydrophilic than the surfaces of typical elastomeric polymers (where a hydrophilic interior surface is desired). Such hydrophilic channel surfaces can thus be more easily filled and wetted with aqueous solutions than can structures comprised of typical, unoxidized elastomeric polymers or other hydrophobic materials.

As described herein, any of a variety of signaling or display methods, associated  
10 with analyses, can be provided including signaling visually, by smell, sound, feel, taste, or the like, in one set of embodiments. Signal structures or generators include, but are not limited to, displays (visual, LED, light, etc.), speakers, chemical-releasing chambers (e.g., containing a volatile chemical), mechanical devices, heaters, coolers, or the like. In some cases, the signal structure or generator may be integral with the device (e.g.,  
15 integrally connected with a substance transfer component for application to the skin of the subject, e.g., such as a needle or a microneedle), or the signal structure may not be integrally connected with the substance transfer component. As used herein, a “signal structure” or a “signal generator” is any apparatus able to generate a signal that is related to a condition of a medium. For example, the medium may be a bodily fluid, such as  
20 blood or interstitial fluid.

In some embodiments, signaling methods such as these may be used to indicate the presence and/or concentration of an analyte determined by the sensor, e.g., to the subject, and/or to another entity, such as those described below. Where a visual signal is provided, it can be provided in the form of change in opaqueness, a change in intensity  
25 of color and/or opaqueness, or can be in the form of a message (e.g., numerical signal, or the like), an icon (e.g., signaling by shape or otherwise a particular medical condition), a brand, logo, or the like. For instance, in one embodiment, the device may include a display. A written message such as “take next dose,” or “glucose level is high” or a numerical value might be provided, or a message such as “toxin is present.” These  
30 messages, icons, logos, or the like can be provided as an electronic read-out by a component of a device and/or can be displayed as in inherent arrangement of one or more components of the device.

In some embodiments, a device is provided where the device determines a physical condition of a subject and produces a signal related to the condition that can be readily understood by the subject (e.g., by provision of a visual “OK” signal as described above) or can be designed so as not to be readily understandable by a subject. Where not readily understandable, the signal can take a variety of forms. In one form, the signal might be a series of letters or numbers that mean nothing to the subject (e.g., A1278CDQ) which would have meaning to a medical professional or the like (and/or be decodable by the same, e.g., with reference to a suitable decoder) and can be associated with a particular physiological condition. Alternatively, a signal in the form of bar code can be provided by a device such that, under a particular condition or set of conditions the bar code appears and/or disappears, or changes, and can be read by a bar code reader to communicate information about the subject or analyte. In another embodiment, the device can be designed such that an ultraviolet signal is produced, or a signal that can be read only under ultraviolet light (e.g., a simple spot or patch, or any other signal such as a series of number, letters, bar code, message, or the like that can be readily understandable or not readily understandable by a subject) can be provided. The signal may be invisible to the human eye but, upon application UV light or other excitation energy, may be readable. The signal can be easily readable or understandable by a user via visual observation, or with other sensory activity such as smell, feel, etc. In another set of embodiments equipment as described above may be needed to determine a signal provided by the device, such as equipment in a clinical setting, etc. In some cases, the device is able to transmit a signal indicative of the analyte to a receiver, e.g., as a wireless signal, a radio signal, etc.

In some embodiments, quantitative and/or qualitative analyses can be provided by a device. That is, the device in some cases may provide analyses that allow “yes/no” tests or the like, or tests that provide information on the quantity, concentration, or level of a particular analyte or analytes. Display configurations can be provided by the invention that reflect the amount of a particular analyte present in a subject at a particular point in time, or any other variable (presence of analysis over time, type of analyte, etc.) display configurations can take a variety of forms. In one example, a dial can be provided, similar to that of a speedometer with a series of level indications (e.g., numbers around the dial) and a “needle” or other device that indicates a particular level.



In other configurations, a particular area of the device (e.g., on a display) can exist that is filled in to a greater or lesser extent depending upon the presence and/or quantity of a particular analyte present, e.g., in the form of a bar graph. In another arrangement a “color wheel” can be provided where the amount of a particular analyte present can control which colors of the wheel are visible. Or, different analytes can cause different colors of a wheel or different bars of a graph to become visible or invisible in a multiple analyte analysis. Multiple-analyte quantitative analyses can be reflected in multiple color wheels, a single color wheel with different colors per analyte where the intensity of each color reflects the amount of the analyte, or, for example, a plurality of bar graphs where each bar graph is reflective of a particular analyte and the level of the bar (and/or degree to which an area is filled in with visible color or other visible feature) is reflective of the amount of the analyte. As with all embodiments here, whatever signal is displayed can be understandable or not understandable to any number of participants. For example, it can be understandable to a subject or not understandable to a subject. Where not understandable it might need to be decoded, read electronically, or the like. Where read electronically, for example, a device may provide a signal that is not understandable to a subject or not even visible or otherwise able to be sensed by a subject, and a reader can be provided adjacent or approximate the device that can provide a visible signal that is understandable or not understandable to the subject, or can transmit a signal to another entity for analysis.

In connection with any signals associated with any analyses described herein, another, potentially related signal or other display (or smell, taste, or the like) can be provided which can assist in interpreting and/or evaluating the signal. In one arrangement, a calibration or control is provided proximate (or otherwise easily comparable with) a signal, e.g., a visual calibration/control or comparator next to or close to a visual signal provided by a device and/or implanted agents, particles, or the like.

A visual control or reference can be used with another sensory signal, such as that of smell, taste, temperature, itch, etc. A reference/control and/or experimental confirmation component can be provided, to be used in connection with an in-skin test or vice versa. References/indicators can also be used to indicate the state of life of a device, changing color or intensity and/or changing in another signaling aspect as the device changes relative to its useful life, so that a user can determine when the device should no

longer be relied upon and/or removed. For certain devices, an indicator or control can be effected by adding analyte to the control (e.g., from a source outside of the source to be determine) to confirm operability of the device and/or to provide a reference against which to measure a signal of the device. For example, a device can include a button to  
5 be tapped by a user which will allow an analyte from a reservoir to transfer to an indicator region to provide a signal, to demonstrate operability of the device and/or provide a comparator for analysis.

Many of the embodiments described herein involve a quantitative analysis and related signal, i.e., the ability to determine the relative amount or concentration of an  
10 analyte in a medium. This can be accomplished in a variety of ways. For example, where an agent (e.g. a binding partner attached to a nanoparticle) is used to capture and analyze an analyte, the agent can be provided in a gradient in concentration across a sensing region of the device. Or a sensing region can include a membrane or other apparatus through which analyte is required to flow or pass prior to capture and  
15 identification, and the pathway for analyte travel can vary as a function of position of display region. For example, a membrane can be provided across a sensing region, through which analyte must pass prior to interacting with a layer of binding and/or signaling agent, and the membrane may vary in thickness laterally in a direction related to “bar graph” readout. Where a small amount of analyte is present, it may pass through  
20 the thinner portion but not the thicker portion of the membrane, but where a larger amount is present, it may pass across a thicker portion. The boundary (where one exists) between a region through which analyte passes, and one through which it does not completely pass, can define the “line” of the bar graph. Other ways of achieving the same or a similar result can include varying the concentration of a scavenger or  
25 transporter of the analyte, or an intermediate reactive species (between analyte and signaling event), across a membrane or other article, gradient in porosity or selectivity of the membrane, ability to absorb or transport sample fluid, or the like. These principles, in combination with other disclosure herein, can be used to facilitate any or all of the quantitative analyses described herein.

30 In one set of embodiments, a subject having a condition such as a physiological condition to be analyzed (or other user, such as medical personnel) reads and/or otherwise determines a signal from a device. For example, the device may transmit a

signal indicative of a condition of the subject and/or the device. Alternatively, or in addition, a signal produced by a device can be acquired in the form of a representation (e.g. a digitized signal, or the like) and transmitted to another entity for analysis and/or action. For example, a signal can be produced by a device, e.g., based on a sensor  
5 reading of an analyte, based on fluid delivered and/or received from the skin, based on a condition of the device, or the like. The signal may represent any suitable data or image. For example, the signal may represent the presence and/or concentration of an analyte in fluid received from a subject, the amount of fluid received from a subject and/or delivered to the subject, the number of times the device has been used, the battery life of  
10 the device, the amount of vacuum left in the device, the cleanliness or sterility of the device, the identity of the device (e.g., where multiple devices are given unique identification numbers, to prevent counterfeiting, accidental exchange of equipment to incorrect users, etc.), or the like. For instance, in one set of embodiments, an image of the signal (e.g., a visual image or photograph) can be obtained and transmitted to a  
15 different entity (for example, a user can take a cell phone picture of a signal generated by the device and send it, via cell phone, the other entity).

The other entity that the signal is transmitted to can be a human (e.g., a clinician) or a machine. In some cases, the other entity may be able to analyze the signal and take appropriate action. In one arrangement, the other entity is a machine or processor that  
20 analyzes the signal and optionally sends a signal back to the device to give direction as to activity (e.g., a cell phone can be used to transmit an image of a signal to a processor which, under one set of conditions, transmits a signal back to the same cell phone giving direction to the user, or takes other action). Other actions can include automatic stimulation of the device or a related device to dispense a medicament or pharmaceutical,  
25 or the like. The signal to direct dispensing of a pharmaceutical can take place via the same used to transmit the signal to the entity (e.g., cell phone) or a different vehicle or pathway. Telephone transmission lines, wireless networks, Internet communication, and the like can also facilitate communication of this type.

As one specific example, a device may be a glucose monitor. As signal may be  
30 generated by the device and an image of the signal captured by a cell phone camera and then transmitted via cell phone to a clinician. The clinician may then determine that the

glucose (or e.g., insulin) level is appropriate or inappropriate and send a message indicating this back to the subject via cell phone.

Information regarding the analysis can also be transmitted to the same or a different entity, or a different location simply by removing the device or a portion of the device from the subject and transferring it to a different location. For example, a device  
5 can be used in connection with a subject to analyze presence and/or amount of a particular analyte. At some point after the onset of use, the device, or a portion of the device carrying a signal or signals indicative of the analysis or analyses, can be removed and, e.g., attached to a record associated with the subject. As a specific example, a patch  
10 or other device can be worn by a subject to determine presence and/or amount of one or more analytes qualitatively, quantitatively, and/or over time. The subject can visit a clinician who can remove the patch (or other device) or a portion of the patch and attach it to a medical record associated with the subject.

According to various sets of embodiments, the device may be used once, or  
15 multiple times, depending on the application. For instance, obtaining samples for sensing, according to certain embodiments of the invention, can be done such that sensing can be carried out continuously, discretely, or a combination of these. For example, where a bodily fluid such as blood or interstitial fluid is accessed for determination of an analyte, fluid can be accessed discretely (i.e., as a single dose, once  
20 or multiple times), or continuously by creating a continuous flow of fluid which can be analyzed once or any number of times. Additionally, testing can be carried out once, at a single point in time, or at multiple points in time, and/or from multiple samples (e.g., at multiple locations relative to the subject).

Alternatively or in addition, testing can be carried out continuously over any  
25 number of points in time involving one or any number of locations relative to the subject or other multiple samples. As an example, one bolus or isolated sample, of fluid such as interstitial fluid can be obtained. From that fluid a test can be carried out to determine whether a particular analyte or other agent exists in the fluid. Alternatively, two or more tests can be carried out involving that quantity of fluid to determine the presence and/or  
30 quantity of two or more analytes, and any number of such tests can be carried out. Tests involving that quantity of fluid can be carried out simultaneously or over a period of time. For example, a test for a particular analyte can be carried out at various points in

time to determine whether the result changes over time, or different analytes can be determined at different points in time.

In another example, a needle or a microneedle, or other device(s) can be used to access a fluid of a subject such as interstitial fluid. Fluid can be drawn to a point of analysis and analyzed in any manner described herein. For example, an analysis can be carried out once, to determine the presence and/or quantity of a single analyte, or a number of tests can be carried out. From a single sample of fluid, a particular test or number of tests can be carried out essentially simultaneously, or analyses can be carried out over time. Moreover, fluid can be drawn continuously from the subject and one or more tests can be carried out of any number of points in time. A variety of reasons for carrying out one or more tests over the course of time exists, as would be understood by those of ordinary skill in the art. One such reason is to determine whether the quantity or another characteristic of an analyte is constant in a subject, or changes over time. A variety of specific techniques for continuous and/or discrete testing will be described herein.

In one set of embodiments, one or more materials, such as particles, are delivered to the skin. Examples of suitable materials include, but are not limited to, particles such as microparticles or nanoparticles, a chemical, a drug or a therapeutic agent, a diagnostic agent, a carrier, or the like. The particles may be, for example, nanoparticles or microparticles, and in some cases, the particles may be anisotropic particles. In some cases, a plurality of particles may be used, and in some cases, some, or substantially all, of the particles may be the same. For example, at least about 10%, at least about 30%, at least about 40%, at least about 50%, at least about 60%, at least about 70%, at least about 80%, at least about 90%, at least about 95%, or at least about 99% of the particles may have the same shape, and/or may have the same composition.

The particles may be used for a variety of purposes. For instance, the particles may contain a diagnostic agent or a reaction entity able to interact with and/or associate with an analyte, or another reaction entity, or other particles. Such particles may be useful, for example, to determine one or more analytes, such as a marker of a disease state, as discussed below. As another example, the particles may contain a drug or a therapeutic agent, positioned on the surface and/or internally of the particles, which may

be released by the particles and delivered to the subject. Specific examples of these and other embodiments are discussed in detail below.

In some cases, materials such as particles may become embedded within the skin, for example, due to physical properties of the materials (e.g., size, hydrophobicity, etc.).

5 Thus, in some cases, a depot of material may be formed within the skin, and the depot may be temporary or permanent. For instance, materials within the depot may eventually degrade (e.g., if the material is biodegradable), enter the bloodstream, or be sloughed off to the environment, e.g., as the cells of the dermis differentiate to form new epidermis and accordingly push the material towards the surface of the skin. Thus, the depot of  
10 material may be present within the subject on a temporary basis (e.g., on a time scale of days or weeks), in certain instances.

As mentioned, certain aspects of the present invention are generally directed to particles such as anisotropic particles or colloids, which can be used in a wide variety of applications. For instance, the particles may be present within the skin, or externally of  
15 the skin, e.g., in a device on the surface of the skin. The particles may include microparticles and/or nanoparticles. As discussed above, a “microparticle” is a particle having an average diameter on the order of micrometers (i.e., between about 1 micrometer and about 1 mm), while a “nanoparticle” is a particle having an average diameter on the order of nanometers (i.e., between about 1 nm and about 1 micrometer).  
20 The particles may be spherical or non-spherical, in some cases. For example, the particles may be oblong or elongated, or have other shapes such as those disclosed in U.S. Patent Application Serial No. 11/851,974, filed September 7, 2007, entitled “Engineering Shape of Polymeric Micro- and Nanoparticles,” by S. Mitragotri, *et al.*; International Patent Application No. PCT/US2007/077889, filed September 7, 2007,  
25 entitled “Engineering Shape of Polymeric Micro- and Nanoparticles,” by S. Mitragotri, *et al.*, published as WO 2008/031035 on March 13, 2008; U.S. Patent Application Serial No. 11/272,194, filed November 10, 2005, entitled “Multi-phasic Nanoparticles,” by J. Lahann, *et al.*, published as U.S. Patent Application Publication No. 2006/0201390 on September 14, 2006; or U.S. Patent Application Serial No. 11/763,842, filed June 15,  
30 2007, entitled “Multi-Phasic Bioadhesive Nan-Objects as Biofunctional Elements in Drug Delivery Systems,” by J. Lahann, published as U.S. Patent Application Publication No. 2007/0237800 on October 11, 2007, each of which is incorporated herein by

reference. Other examples of particles can be seen in U.S. Patent Application Serial No. 11/272,194, filed November 10, 2005, entitled "Multi-phasic Nanoparticles," by J. Lahann, *et al.*, published as U.S. Patent Application Publication No. 2006/0201390 on September 14, 2006; U.S. Patent Application Serial No. 11/763,842, filed June 15, 2007, 5 entitled "Multi-Phasic Bioadhesive Nan-Objects as Biofunctional Elements in Drug Delivery Systems," by J. Lahann, published as U.S. Patent Application Publication No. 2007/0237800 on October 11, 2007; or U.S. Provisional Patent Application Serial No. 61/058,796, filed June 4, 2008, entitled "Compositions and Methods for Diagnostics, Therapies, and Other Applications," by D. Levinson, each of which is incorporated 10 herein by reference. Other examples of particles can be seen in U.S. Patent Application Serial No. 11/272,194, filed November 10, 2005, entitled "Multi-phasic Nanoparticles," by J. Lahann, *et al.*, published as U.S. Patent Application Publication No. 2006/0201390 on September 14, 2006; U.S. Patent Application Serial No. 11/763,842, filed June 15, 2007, entitled "Multi-Phasic Bioadhesive Nan-Objects as Biofunctional Elements in 15 Drug Delivery Systems," by J. Lahann, published as U.S. Patent Application Publication No. 2007/0237800 on October 11, 2007; or U.S. Provisional Patent Application Serial No. 61/058,796, filed June 4, 2008, entitled "Compositions and Methods for Diagnostics, Therapies, and Other Applications," by D. Levinson, each of which is incorporated herein by reference.

20 In some cases, a pooled region of fluid, such as a suction blister, may be formed in the skin to facilitate delivery and/or receiving of fluid from the skin. Thus, certain aspects of the present invention are generally directed to the creation of suction blisters or other pooled regions of fluid within the skin. In one set of embodiments, a pooled region of fluid can be created between the dermis and epidermis of the skin. Suction 25 blisters or other pooled regions may form in a manner such that the suction blister or other pooled region is not significantly pigmented in some cases, since the basal layer of the epidermis contains melanocytes, which are responsible for producing pigments. Such regions can be created by causing the dermis and the epidermis to at least partially separate, and as will be discussed below, a number of techniques can be used to at least 30 partially separate the dermis from the epidermis.

In one technique, a pool of interstitial fluid is formed between layers of skin of a subject and, after forming the pool, fluid is drawn from the pool by accessing the fluid

through a layer of skin, for example, puncturing the outer layer of skin with a microneedle. Specifically, for example, a suction blister can be formed and then the suction blister can be punctured and fluid can be drawn from the blister. In another technique, an interstitial region can be accessed and fluid drawn from that region without first forming a pool of fluid via a suction blister or the like. For example, a microneedle or microneedles can be applied to the interstitial region and fluid can be drawn there from.

Pooled regions of fluids may be formed on any suitable location within the skin of a subject. Factors such as safety or convenience may be used to select a suitable location, as (in humans) the skin is relatively uniform through the body, with the exception of the hands and feet. As non-limiting examples, the pooled region may be formed on an arm or a leg, on the chest, abdomen, or the back of the subject, or the like. The size of the pooled region of fluid that is formed in the skin and/or the duration that the pooled region lasts within the skin depends on a variety of factors, such as the technique of creating the pooled region, the size of the pooled region, the size of the region of skin to which the technique is applied, the amount of fluid received from the pooled region (if any), any materials that are delivered into the pooled region, or the like. For example, if vacuum is applied to the skin to create a suction blister, the vacuum applied to the skin, the duration of the vacuum, and/or the area of the skin affected may be controlled to control the size and/or duration of the suction blister. In some embodiments, it may be desirable to keep the pooled regions relatively small, for instance, to prevent an unsightly visual appearance, to allow for greater sampling accuracy (due to a smaller volume of material), or to allow for more controlled placement of particles within the skin. For example, the volume of the pooled region may be kept to less than about 2 ml or less than about 1 ml in certain cases, or the average diameter of the pooled region (i.e., the diameter of a circle having the same area as the pooled region) may be kept to less than about 5 cm, less than about 4 cm, less than about 3 cm, less than about 2 cm, less than about 1 cm, less than about 5 mm, less than about 4 mm, less than about 3 mm, less than about 2 mm, or less than about 1 mm.

A variety of techniques may be used to cause pooled regions of fluid to form within the skin. In one set of embodiments, vacuum is applied to create a suction blister, or otherwise used to collect interstitial fluid from a subject. In other embodiments,



however, other methods may be used to create as a pooled region of fluid within the skin besides, or in addition to, the use of vacuum. When vacuum (i.e., the amount of pressure below atmospheric pressure, such that atmospheric pressure has a vacuum of 0 mmHg, i.e., the pressure is gauge pressure rather than absolute pressure) is used to at least

5 partially separate the dermis from the epidermis to cause the pooled region to form, the pooled region of fluid thus formed can be referred to as a suction blister. For example, vacuums of at least about 50 mmHg, at least about 100 mmHg, at least about 150 mmHg, at least about 200 mmHg, at least about 250 mmHg, at least about 300 mmHg, at least about 350 mmHg, at least about 400 mmHg, at least about 450 mmHg, at least about 500

10 mmHg, at least about 550 mmHg, at least about 600 mmHg, at least about 650 mmHg, at least about 700 mmHg, or at least about 750 mmHg may be applied to the skin, e.g., to cause a suction blister and/or to collect interstitial fluid from a subject (as discussed, these measurements are negative relative to atmospheric pressure. Different amounts of vacuum may be applied to different subjects in some cases, for example, due to

15 differences in the physical characteristics of the skin of the subjects.

The vacuum may be applied to any suitable region of the skin, and the area of the skin to which the vacuum may be controlled in some cases. For instance, the average diameter of the region to which vacuum is applied may be kept to less than about 5 cm, less than about 4 cm, less than about 3 cm, less than about 2 cm, less than about 1 cm,

20 less than about 5 mm, less than about 4 mm, less than about 3 mm, less than about 2 mm, or less than about 1 mm. In addition, such vacuums may be applied for any suitable length of time at least sufficient to cause at least some separation of the dermis from the epidermis to occur. For instance, vacuum may be applied to the skin for at least about 1 min, at least about 3 min, at least about 5 min, at least about 10 min, at least about 15

25 min, at least about 30 min, at least about 1 hour, at least about 2 hours, at least about 3 hours, at least about 4 hours, etc. Examples of devices suitable for creating such suction blisters are discussed in more detail below. In other cases, however, bodily fluids such as blood or interstitial fluid may be received from the skin using vacuum without the creation of a suction blister. Other non-limiting fluids include saliva, sweat, tears,

30 mucus, plasma, lymph, or the like.

Other methods besides vacuum may be used to cause such separation to occur. For example, in another set of embodiments, heat may be used. For instance, a portion

of the skin may be heated to at least about 40 °C, at least about 50 °C, at least about 55 °C, or at least about 60 °C, using any suitable technique, to cause such separation to occur. The skin may be heated, for instance, using an external heat source (e.g., radiant heat or a heated water bath), a chemical reaction, electromagnetic radiation (e.g.,  
5 microwave radiation, infrared radiation, etc.), or the like. In some cases, the radiation may be focused on a relatively small region of the skin, e.g., to at least partially spatially contain the amount of heating within the skin that occurs.

In yet another set of embodiments, a separation chemical may be applied to the skin to at least partially cause separation of the dermis and the epidermis to occur. Non-  
10 limiting examples of such separation chemicals include proteases such as trypsin, purified human skin tryptase, or compound 48/80. Separation compounds such as these are commercially available from various sources. The separation chemical may be applied directly to the skin, e.g., rubbed into the surface of the skin, or in some cases, the separation chemical can be delivered into the subject, for example, between the  
15 epidermis and dermis of the skin. The separation chemical can, for example, be injected in between the dermis and the epidermis.

Another example of a separation chemical is a blistering agent, such as pit viper venom or blister beetle venom. Non-limiting examples of blistering agents include phosgene oxime, Lewisite, sulfur mustards (e.g., mustard gas or 1,5-dichloro-3-  
20 thiapentane, 1,2-bis(2-chloroethylthio)ethane, 1,3-bis(2-chloroethylthio)-n-propane, 1,4-bis(2-chloroethylthio)-n-butane, 1,5-bis(2-chloroethylthio)-n-pentane, 2-chloroethylchloromethylsulfide, bis(2-chloroethyl)sulfide, bis(2-chloroethylthio)methane, bis(2-chloroethylthiomethyl)ether, or bis(2-chloroethylthioethyl)ether), or nitrogen mustards (e.g., bis(2-chloroethyl)ethylamine,  
25 bis(2-chloroethyl)methylamine, or tris(2-chloroethyl)amine).

In still another set of embodiments, a device may be inserted into the skin and used to mechanically separate the epidermis and the dermis, for example, a wedge or a spike. Fluids may also be used to separate the epidermis and the dermis, in yet another set of embodiments. For example, saline or another relatively inert fluid may be injected  
30 into the skin between the epidermis and the dermis to cause them to at least partially separate.

These and/or other techniques may also be combined, in still other embodiments. For example, in one embodiment, vacuum and heat may be applied to the skin of a subject, sequentially and/or simultaneously, to cause such separation to occur. As a specific example, in one embodiment, vacuum is applied while the skin is heated to a  
5 temperature of between about 40 °C and about 50 °C.

One aspect of the present invention is directed to an adaptor able to position a device of the invention in apparatuses designed to contain Vacutainer™ tubes or Vacuette™ tubes. In some cases, the Vacutainer or Vacuette tube sizes have a maximum length of no more than about 75 mm or about 100 mm and a diameter of no more than  
10 about 16 mm or about 13 mm. In some cases, the adaptor may be able to immobilize a device of the invention therein, e.g., for subsequent use or processing. In some cases, as previously discussed, devices of the invention may have a largest lateral dimension of no more than about 50 mm, and/or a largest vertical dimension, extending from the skin of the subject when the device is applied to the subject, of no more than about 10 mm. An  
15 example of such a device is shown in Fig. 9, with device 800 contained within adapter 850. The device may be contained within the adaptor using any suitable technique, e.g., using clips, springs, braces, bands, or the application of force to the device present within the adaptor.

In another aspect, the present invention is directed to a kit including one or more  
20 of the compositions previously discussed, e.g., a kit including a device for the delivery and/or receiving of fluid from the skin, a kit including a device able to create a pooled region of fluid within the skin of a subject, a kit including a device able to determine a fluid, or the like. An example of a kit containing more than one device of the invention is illustrated in Fig. 2D, with kit 150 containing devices 152. A “kit,” as used herein,  
25 typically defines a package or an assembly including one or more of the compositions or devices of the invention, and/or other compositions or devices associated with the invention, for example, as previously described. For example, in one set of embodiments, the kit may include a device and one or more compositions for use with the device. Each of the compositions of the kit, if present, may be provided in liquid  
30 form (e.g., in solution), or in solid form (e.g., a dried powder). In certain cases, some of the compositions may be constitutable or otherwise processable (e.g., to an active form), for example, by the addition of a suitable solvent or other species, which may or may not

be provided with the kit. Examples of other compositions or components associated with the invention include, but are not limited to, solvents, surfactants, diluents, salts, buffers, emulsifiers, chelating agents, fillers, antioxidants, binding agents, bulking agents, preservatives, drying agents, antimicrobials, needles, syringes, packaging materials, tubes, bottles, flasks, beakers, dishes, frits, filters, rings, clamps, wraps, patches, containers, tapes, adhesives, and the like, for example, for using, administering, modifying, assembling, storing, packaging, preparing, mixing, diluting, and/or preserving the compositions components for a particular use, for example, to a sample and/or a subject.

10 A kit of the invention may, in some cases, include instructions in any form that are provided in connection with the compositions of the invention in such a manner that one of ordinary skill in the art would recognize that the instructions are to be associated with the compositions of the invention. For instance, the instructions may include instructions for the use, modification, mixing, diluting, preserving, administering, assembly, storage, packaging, and/or preparation of the compositions and/or other compositions associated with the kit. In some cases, the instructions may also include instructions for the delivery and/or administration of the compositions, for example, for a particular use, e.g., to a sample and/or a subject. The instructions may be provided in any form recognizable by one of ordinary skill in the art as a suitable vehicle for containing such instructions, for example, written or published, verbal, audible (e.g., telephonic), digital, optical, visual (e.g., videotape, DVD, etc.) or electronic communications (including Internet or web-based communications), provided in any manner.

In some embodiments, the present invention is directed to methods of promoting one or more embodiments of the invention as discussed herein. As used herein, “promoted” includes all methods of doing business including, but not limited to, methods of selling, advertising, assigning, licensing, contracting, instructing, educating, researching, importing, exporting, negotiating, financing, loaning, trading, vending, reselling, distributing, repairing, replacing, insuring, suing, patenting, or the like that are associated with the systems, devices, apparatuses, articles, methods, compositions, kits, etc. of the invention as discussed herein. Methods of promotion can be performed by any party including, but not limited to, personal parties, businesses (public or private),

partnerships, corporations, trusts, contractual or sub-contractual agencies, educational institutions such as colleges and universities, research institutions, hospitals or other clinical institutions, governmental agencies, etc. Promotional activities may include communications of any form (e.g., written, oral, and/or electronic communications, such as, but not limited to, e-mail, telephonic, Internet, Web-based, etc.) that are clearly associated with the invention.

In one set of embodiments, the method of promotion may involve one or more instructions. As used herein, "instructions" can define a component of instructional utility (e.g., directions, guides, warnings, labels, notes, FAQs or "frequently asked questions," etc.), and typically involve written instructions on or associated with the invention and/or with the packaging of the invention. Instructions can also include instructional communications in any form (e.g., oral, electronic, audible, digital, optical, visual, etc.), provided in any manner such that a user will clearly recognize that the instructions are to be associated with the invention, e.g., as discussed herein.

The following examples are intended to illustrate certain embodiments of the present invention, but do not exemplify the full scope of the invention.

### **EXAMPLE 1**

In this example, various devices as discussed above were applied to subjects and the degree of pain evaluated using the Wong-Baker FACES Pain Scale, as compared to a commercially available device. The devices included various microneedles in fluidic communication with a reservoir for storing blood received from the device. A prepackaged vacuum on the device was used to extract the blood, and the microneedles were injected by the device into the skin using a "snap dome" such as is shown in Fig. 11.

Four such devices were tested: the first device include 4 microneedles, each 750 micrometers long ("4x750"); the second device included 8 microneedles, each 750 micrometers long ("8x750"); the third device included 16 microneedles, each 750 micrometers long ("16x750"); and the fourth device included 4 microneedles, each 1000 micrometers long ("4x1000"). All of the microneedles were solid. The fifth control device tested was the commercially available Accu-Check Multiclix device (Roche Diagnostics Corp.) ("Multi-Clix"). This device has a needle of 28G-30G gauge. The

devices were applied to various subjects to draw blood. For the “4x750” device, 16.2 microliters of blood were drawn. For the “8x750” device, 22.9 microliters of blood were drawn. For the “16x750” device, 36.6 microliters of blood were drawn. For the “4x1000” device, 21.3 microliters of blood were drawn. After blood was drawn using one of the devices, the subject was asked to rate the amount of pain felt using the Wong-Baker scale. Data from these experiments are shown in Table 1 (“Array” indicates the device, “Average” represents the average Wong-Baker FACES Pain Scale for the device, “Stdev” represents the standard deviation, “number” represents the number of trials for each device.

10

Table 1

Array	4x750	8x750	16x750	4x1000	Multi-Clix
Average	0.40	0.60	0.82	0.80	3.90
Stdev	0.51	0.62	0.75	0.56	1.33
Number	15	60	60	15	20

15

The results of these experiments are shown in Fig. 13. As can be seen in this figure, each of the four devices tested had Wong-Baker values significantly less than the control Multi-Clix device. On average, subjects using any of the devices experienced at least 70% less pain than the pain experienced from using the control Multi-Clix device. Accordingly, each of these four devices causes the subject to experience significantly less pain than commercially available devices. In addition, in at least some cases, no pain is felt when the test devices are applied to a subject, as indicated by the error bars (indicating standard deviations) on the Wong-Baker scale that contact or even cross the 0 axis. Also, as can be seen from the data, subjects using any of the devices experienced, on average, no more than the 10<sup>th</sup> percentile (10%) of pain as measured from the lowest pain indication to the highest pain indication. Additionally, all subjects using any of the devices experienced no more than the 25<sup>th</sup> percentile (25%) of pain as measured from the lowest pain indication to the highest pain indication.

30 **EXAMPLE 2**

This example illustrates a device for inserting a microneedle array into the skin of a subject. Fig. 15A shows a device 800 including a substance transfer component (e.g., including a microneedle array 833), a deployment actuator (e.g., snap dome 832), an activator (e.g., activation button 831), a retraction actuator (e.g., silicone foam 835), and

structural components constructed from multiple layers of polycarbonate bonded together using a double-sided adhesive, such as 3M 1509 or 3M 1513 tape. The microneedle arrays can be bonded to laminated post 837 on the underside of a snap dome. Structural components 838, as well as post 837, are formed from polycarbonate and 3M 1509 or 3M 1513 adhesive. The arrays may range in needle number (4 to 28 needles), needle length (350 to 1000 micrometers), and/or arrangement (square, rectangular, and circular arrays), with array footprints of less than 3 mm in diameter, where the "footprint" is the area of the base to which the needles are attached. Arrangements with multiple arrays are possible as well. For example, an arrangement may have 3 arrays bonded to post 837, each array with its own set of needles. Each array may contain 4-28 needles, thus the total number of needles in a 3 array arrangement may range from 12-84 needles. Arrangements with 3 arrays, 4 arrays, 7 arrays, or other suitable number of arrays are all possible. A device with 4 arrays may have 16-112 total needles and a device with 7 arrays may have 28-196 total needles.

In use, the device may be charged by setting the snap dome in a high energy position, placing the base of the device against the skin of a subject (with the needle tips pointing towards the skin), and pushing button 831 on the top of the device. As the button is pressed, silicone foam 835 compresses, positioning the needle tips in close proximity to the skin through opening 840. When the foam is fully compressed, the force causes the button to collapse, which then translates to the back of the snap dome to cause it to move to a stable low energy state. The release of energy from the snap dome changing states accelerates the microneedle array forward through the opening in the base and inserts the needles into the skin. When the force on the button is released, the silicone foam expands to its original height and retracts the needles from the skin in the process.

### EXAMPLE 3

This example illustrates a device for withdrawing blood using vacuum. This device is shown in Fig. 15B. This device includes a vacuum chamber comprising layers of polycarbonate, polyethylene terephthalate glycol (PETG), and silicone bonded together using a double-sided adhesive, such as 3M 1509 or 3M 1513 tape. The chamber is approximately 2.7 cm in diameter and 0.6 cm high, with cup opening 858 (substance transfer component) in the base that ranges from 3 to 7 mm in diameter. The vacuum

chamber may be attached to the skin of a subject over the microneedle insertion site using adhesive 857, such as 3M 1509 or Katecho 10G hydrogel. A vacuum source (i.e., vacuum pump, syringe, vacuum reservoir, etc.) can be connected to the chamber using hypodermic needle 859 inserted through silicone layer 852, and vacuum (i.e., 30 to 70 kPa) may be applied to the site for a fixed period of time (i.e., 10 s to 10 min). The application of vacuum causes blood to flow from the skin punctures into the vacuum chamber.

#### EXAMPLE 4

In this example, a fully integrated device was constructed for the withdrawal of a fluid from human subjects. A diagram of the device is shown in Fig. 15C. In this example, the integrated device 800 includes a housing 801 for application to the skin of the subject. The housing is constructed from multiple layers of polyethylene terephthalate glycol (PETG). These layers may be formed into the requisite geometry by machining sheet stock or injection molding. The individual layers are bonded together using double-sided adhesive, such as 3M 1513 tape, but may also be bonded using non-adhesive methods such as ultrasonic welding or laser welding. The housing is attached to the skin of a subject using an adhesive 802, such as Katecho 10G hydrogel.

The left side of the housing in Fig. 15C houses the components necessary to insert a microneedle array into the skin. These components include a circular microneedle array of sixteen 750 micrometer-long needles 803 actuated by the activator 804 comprising a deployment actuator (e.g., a snap dome 805), a button 806, and a foam return mechanism 807. Pressing the button initially compresses the foam, bringing the microneedles into close proximity with the skin, and then fires the snap dome, moving it from the first stable configuration to the second stable configuration. The movement of the snap dome accelerates and inserts the microneedles into the skin. Releasing the pressure on the button allows the foam to expand and retract the microneedles from the skin.

The right side of the housing shown in Fig. 15C houses a self contained vacuum chamber 808 fluidically connected to a storage chamber 809. The storage chamber is fluidically connected to the activator by a microfluidic channel 810. Pressing the button 811 breaks a seal and causes the fluidically connected components to be evacuated as



well as reduces the pressure on the skin below the microneedle array. This reduced pressure urges blood from the skin into the microfluidic channel and into the storage chamber.

5           The following documents are incorporated herein by reference: U.S. Provisional Patent Application Serial No. 61/058,796, filed June 4, 2008, entitled “Compositions and Methods for Diagnostics, Therapies, and Other Applications”; U.S. Provisional Patent Application Serial No. 61/163,791, filed March 26, 2009, entitled “Composition and Methods for Rapid One-Step Diagnosis”; U.S. Provisional Patent Application Serial No. 10 61/163,793, filed March 26, 2009, entitled “Compositions and Methods for Diagnostics, Therapies, and Other Applications”; U.S. Patent Application Serial No. 12/478,756, filed June 4, 2009, entitled “Compositions and Methods for Diagnostics, Therapies, and Other Applications”; International Patent Application No. PCT/US09/046333, filed June 4, 2009, entitled “Compositions and Methods for Diagnostics, Therapies, and Other 15 Applications”; U.S. Provisional Patent Application Serial No. 61/163,710, filed March 26, 2009, entitled “Systems and Methods for Creating and Using Suction Blisters or Other Pooled Regions of Fluid within the Skin”; U.S. Provisional Patent Application Serial No. 61/163,733, filed March 26, 2009, entitled “Determination of Tracers within Subjects”; U.S. Provisional Patent Application Serial No. 61/163,750, filed March 26, 20 2009, entitled “Monitoring of Implants and Other Devices”; U.S. Provisional Patent Application Serial No. 61/154,632, filed March 2, 2009, entitled “Oxygen Sensor”; and U.S. Provisional Patent Application Serial No. 61/269,436, filed June 24, 2009, entitled “Devices and Techniques associated with Diagnostics, Therapies, and Other Applications, Including Skin-Associated Applications.” Also incorporated by reference 25 herein are U.S. Provisional Patent Application Serial No. 61/263,882, filed November 24, 2009, entitled “Patient-Enacted Sampling Technique”; U.S. Provisional Patent Application Serial No. 61/294,543, filed January 13, 2010, entitled “Blood Sampling Device and Method”; U.S. Patent Application Serial No. 12/716,222, filed March 2, 2010, entitled “Oxygen Sensor,” by Levinson, *et al.*; U.S. Patent Application Serial No. 30 12/716,233, filed March 2, 2010, entitled “Systems and Methods for Creating and Using Suction Blisters or Other Pooled Regions of Fluid within the Skin,” by Levinson, *et al.*; U.S. Patent Application Serial No. 12/716,226, filed March 2, 2010, entitled

“Techniques and Devices Associated with Blood Sampling,” by Levinson, *et al.*; U.S. Patent Application Serial No. 12/716,229, filed March 2, 2010, entitled “Devices and Techniques Associated with Diagnostics, Therapies, and Other Applications, Including Skin-Associated Applications,” by Bernstein, *et al.*; U.S. Provisional Patent Application  
5 Serial No. 61/256,880, filed October 30, 2009, entitled “Systems and Methods for Altering or Masking Perception of Treatment of a Subject,” by Chickering, *et al.*; U.S. Provisional Patent Application Serial No. 61/256,874, filed October 30, 2009, entitled “Systems and Methods for Application to Skin and Control of Use Thereof,” by  
Benstein, *et al.*; U.S. Provisional Patent Application Serial No. 61/256,871, filed October  
10 30, 2009, entitled “Packaging Systems and Methods for Devices Applied to the Skin,” by Bernstein, *et al.*; U.S. Provisional Patent Application Serial No. 61/334,533, filed May 13, 2010, entitled “Blood Sampling Device and Method,” by Chickering, *et al.*; U.S. Provisional Patent Application Serial No. 61/334,529, filed May 13, 2010, entitled “Sampling Device Interfaces,” by Chickering, *et al.*; and U.S. Patent Application Serial  
15 No. 13/006,165, filed January 13, 2011, entitled “Sampling Device Interfaces” by Chickering, *et al.*

While several embodiments of the present invention have been described and illustrated herein, those of ordinary skill in the art will readily envision a variety of other means and/or structures for performing the functions and/or obtaining the results and/or  
20 one or more of the advantages described herein, and each of such variations and/or modifications is deemed to be within the scope of the present invention. More generally, those skilled in the art will readily appreciate that all parameters, dimensions, materials, and configurations described herein are meant to be exemplary and that the actual  
parameters, dimensions, materials, and/or configurations will depend upon the specific  
25 application or applications for which the teachings of the present invention is/are used. Those skilled in the art will recognize, or be able to ascertain using no more than routine experimentation, many equivalents to the specific embodiments of the invention described herein. It is, therefore, to be understood that the foregoing embodiments are  
presented by way of example only and that, within the scope of the appended claims and  
30 equivalents thereto, the invention may be practiced otherwise than as specifically described and claimed. The present invention is directed to each individual feature, system, article, material, kit, and/or method described herein. In addition, any

combination of two or more such features, systems, articles, materials, kits, and/or methods, if such features, systems, articles, materials, kits, and/or methods are not mutually inconsistent, is included within the scope of the present invention.

All definitions, as defined and used herein, should be understood to control over  
5 dictionary definitions, definitions in documents incorporated by reference, and/or ordinary meanings of the defined terms.

The indefinite articles “a” and “an,” as used herein in the specification and in the claims, unless clearly indicated to the contrary, should be understood to mean “at least one.”

10 The phrase “and/or,” as used herein in the specification and in the claims, should be understood to mean “either or both” of the elements so conjoined, i.e., elements that are conjunctively present in some cases and disjunctively present in other cases. Multiple elements listed with “and/or” should be construed in the same fashion, i.e., “one or more” of the elements so conjoined. Other elements may optionally be present other  
15 than the elements specifically identified by the “and/or” clause, whether related or unrelated to those elements specifically identified. Thus, as a non-limiting example, a reference to “A and/or B”, when used in conjunction with open-ended language such as “comprising” can refer, in one embodiment, to A only (optionally including elements other than B); in another embodiment, to B only (optionally including elements other  
20 than A); in yet another embodiment, to both A and B (optionally including other elements); etc.

As used herein in the specification and in the claims, “or” should be understood to have the same meaning as “and/or” as defined above. For example, when separating items in a list, “or” or “and/or” shall be interpreted as being inclusive, i.e., the inclusion  
25 of at least one, but also including more than one, of a number or list of elements, and, optionally, additional unlisted items. Only terms clearly indicated to the contrary, such as “only one of” or “exactly one of,” or, when used in the claims, “consisting of,” will refer to the inclusion of exactly one element of a number or list of elements. In general, the term “or” as used herein shall only be interpreted as indicating exclusive alternatives  
30 (i.e. “one or the other but not both”) when preceded by terms of exclusivity, such as “either,” “one of,” “only one of,” or “exactly one of.” “Consisting essentially of,” when used in the claims, shall have its ordinary meaning as used in the field of patent law.

As used herein in the specification and in the claims, the phrase “at least one,” in reference to a list of one or more elements, should be understood to mean at least one element selected from any one or more of the elements in the list of elements, but not necessarily including at least one of each and every element specifically listed within the list of elements and not excluding any combinations of elements in the list of elements. This definition also allows that elements may optionally be present other than the elements specifically identified within the list of elements to which the phrase “at least one” refers, whether related or unrelated to those elements specifically identified. Thus, as a non-limiting example, “at least one of A and B” (or, equivalently, “at least one of A or B,” or, equivalently “at least one of A and/or B”) can refer, in one embodiment, to at least one, optionally including more than one, A, with no B present (and optionally including elements other than B); in another embodiment, to at least one, optionally including more than one, B, with no A present (and optionally including elements other than A); in yet another embodiment, to at least one, optionally including more than one, A, and at least one, optionally including more than one, B (and optionally including other elements); etc.

It should also be understood that, unless clearly indicated to the contrary, in any methods claimed herein that include more than one step or act, the order of the steps or acts of the method is not necessarily limited to the order in which the steps or acts of the method are recited.

In the claims, as well as in the specification above, all transitional phrases such as “comprising,” “including,” “carrying,” “having,” “containing,” “involving,” “holding,” “composed of,” and the like are to be understood to be open-ended, i.e., to mean including but not limited to. Only the transitional phrases “consisting of” and “consisting essentially of” shall be closed or semi-closed transitional phrases, respectively, as set forth in the United States Patent Office Manual of Patent Examining Procedures, Section 2111.03.

What is claimed is:

**CLAIMS**

1. A device for essentially pain-free receiving of blood or other substance from the skin of a subject, the device comprising:  
5 a substance transfer component for receiving blood from the skin of the subject,  
wherein the device is constructed and arranged to insert at least a portion of the substance transfer component into the skin, and to receive blood from the subject, with an average pain indication over at least 10 subjects, from prior to  
10 insertion into the skin of the subject through receiving of at least 10 microliters of blood from the subject, of significantly less than the pain experienced from a blood sampling using a standard spring-loaded 21-gauge retractable finger lancet.
2. The device of claim 1, wherein the device is constructed and arranged to insert at  
15 least a portion of the substance transfer component into the skin, and to receive blood from the subject, with an average pain indication over at least 10 subjects, from prior to insertion into the skin of the subject through receiving of at least 10 microliters of blood from the subject, of significantly less than the pain  
20 experienced from a blood sampling using a standard spring-loaded 23-gauge retractable finger lancet.
3. The device of claim 1, wherein the device is constructed and arranged to insert at  
25 least a portion of the substance transfer component into the skin, and to receive blood from the subject, with an average pain indication over at least 10 subjects, from prior to insertion into the skin of the subject through receiving of at least 10 microliters of blood from the subject, of significantly less than the pain  
experienced from a blood sampling using a standard spring-loaded 25-gauge retractable finger lancet.
- 30 4. The device of claim 1, wherein the device is constructed and arranged to insert at least a portion of substance transfer component into the skin, and to receive blood from the subject, with an average pain indication over at least 10 subjects, from

prior to insertion into the skin of the subject through receiving of at least 10 microliters of blood from the subject, of significantly less than the pain experienced from a blood sampling using a standard spring-loaded 26-gauge retractable finger lancet.

5

5. The device of claim 1, wherein the device is constructed and arranged to insert at least a portion of substance transfer component into the skin, and to receive blood from the subject, with an average pain indication over at least 10 subjects, from prior to insertion into the skin of the subject through receiving of at least 10 microliters of blood from the subject, of significantly less than the pain experienced from a blood sampling using a standard spring-loaded 28-gauge retractable finger lancet.

10

6. The device of claim 5, wherein an average pain indication experienced from a 1-microliter blood sampling using the device is at least 70% less painful than an average pain indication experienced from a blood sampling using the standard 28-gauge retractable finger lancet, wherein both average pain indications are measured from at least 10 subjects using the Wong-Baker FACES Pain Scale.

15

7. The device of claim 1, wherein the device is constructed and arranged to insert at least a portion of substance transfer component into the skin, and to receive blood from the subject, with an average pain indication over at least 10 subjects, from prior to insertion into the skin of the subject through receiving of at least 10 microliters of blood from the subject, of significantly less than the pain experienced from a blood sampling using a standard spring-loaded 30 gauge retractable finger lancet.

20

25

8. The device of claim 7, wherein an average pain indication experienced from a 10 microliter blood sampling using the device is at least 70% less painful than an average pain indication experienced from a blood sampling using the standard 30 gauge retractable finger lancet, wherein both average pain indications are measured from at least 10 subjects using the Wong-Baker FACES Pain Scale.

30

9. The device of claim 1, wherein the device is constructed and arranged to insert at least a portion of substance transfer component into the skin, and to receive blood from the subject, with an average pain indication over at least 10 subjects, from  
5 prior to insertion into the skin of the subject through receiving of at least 10 microliters of blood from the subject, of significantly less than the pain experienced from a blood sampling using a standard spring-loaded 33-gauge retractable finger lancet.
- 10 10. A device for essentially pain-free receiving of blood or other substance from the skin of a subject, the device comprising:  
a substance transfer component for receiving blood or other substance from the skin of the subject, wherein the device is constructed and arranged to insert at least a portion of substance transfer component into the skin, and to  
15 receive blood from the subject, with an average pain indication over at least 10 subjects, from prior to insertion into the skin of the subject through receiving of at least 10 microliters of blood from the subject, of no more than 25% of the highest pain indication, as measured from the lowest pain indication to the highest pain indication according to at least one of the following pain scales: the  
20 Wong-Baker Faces Pain Scale, the Visual Analog Pain Scale, or the Numerical Pain Rating Scale.
11. The device of claim 10, wherein the device is constructed and arranged to insert at least a portion of substance transfer component into the skin, and to receive  
25 blood from the subject, with an average pain indication over at least 10 subjects, from prior to insertion into the skin of the subject through receiving of at least 10 microliters of blood from the subject, of no more than 10% of the highest pain indication, as measured from the lowest pain indication to the highest pain indication according to each of the following pain scales: the Wong-Baker Faces  
30 pain scale, the Visual Analog Pain Scale, or the Numerical Pain Rating Scale.

12. The device of claim 10, wherein the device is constructed and arranged to receive blood from the subject at a rate of at least 5 microliters per minute, with an average pain indication over at least 10 subjects of no more than 25% of the highest pain indication, as measured from the lowest pain indication to the highest pain indication according to at least one of the following pain scales: the Wong-Baker Faces Pain Scale, the Visual Analog Pain Scale, or the Numerical Pain Rating Scale.
13. The device of claim 10, wherein the substance transfer component includes at least one microneedle for insertion into the skin of the subject, wherein at full insertion into the skin, the at least one microneedle has an insertion depth of at least 200 microns and a cross-sectional area, at the surface of the skin, of at least 2500 square microns.
14. The device of claim 13, wherein the substance transfer component includes at least 6 microneedles for insertion into the skin of the subject.
15. The device of claim 14, wherein each of the at least 6 microneedles has, at full insertion into the skin, an insertion depth of at least 200 microns and a cross-sectional area, at the surface of the skin, of at least 2500 square microns.
16. The device of claim 10, having a subject-to-subject blood draw consistency such that at least 80% of subjects to which the device is applied for blood receiving experience an at least 10 microliter release with an average pain indication, from prior to insertion into the skin of the subject through receipt of at least 10 microliters of blood from the subject, of no more than 25% of the highest pain indication, as measured from the lowest pain indication to the highest pain indication according to at least one of the following pain scales: the Wong-Baker Faces Pain Scale, the Visual Analog Pain Scale, or the Numerical Pain Rating Scale.



17. A device for receiving a substance from the skin of a subject, and/or for delivering a substance to the skin of a subject, the device comprising:  
a substance transfer component for insertion into the skin of a subject, having a pre-deployed position and a deployed position; and  
5 a deployment actuator, operably linkable to the substance transfer component, the deployment actuator switchable from a first stable configuration, through an unstable configuration, to a second stable configuration, wherein in the first stable configuration, the substance transfer component is not contactable with the skin of the subject, and in the second stable configuration, the substance  
10 transfer component is insertable in the skin of the subject,  
and wherein the substance transfer component is constructed and arranged to deliver, to the skin of the subject, a substance selected from the group consisting of a peptide, a protein, a carbohydrate, a nucleoprotein, a mucoprotein, a lipoprotein, a glycoprotein, a nucleic acid, a nucleotide, nucleoside, a lipid, and  
15 a biologically active organic molecule.
18. The device of claim 17, wherein the substance transfer component includes a plurality of skin insertion objects.
- 20 19. The device of claim 18, wherein at least some of the skin insertion objects comprise needles.
20. The device of claim 18, wherein at least some of the skin insertion objects comprise microneedles.  
25
21. The device of claim 18, wherein at least some of the skin insertion objects are at least partially coated with a substance arranged to be delivered to the subject when the skin insertion objects are inserted into the skin.
- 30 22. The device of claim 21, wherein the substance arranged to be delivered to the subject is selected from the group consisting of a peptide, a protein, a carbohydrate, a nucleoprotein, a mucoprotein, a lipoprotein, a glycoprotein, a

nucleic acid, a nucleotide, nucleoside, a lipid, and a biologically active organic molecule.

23. The device of claim 21, wherein the substance is an analgesic.
- 5
24. The device of claim 23, wherein the analgesic comprises one or more of lidocaine, bupivacaine, and tetracaine.
- 10 25. The device of claim 18, wherein at least some of the skin insertion objects are hollow.
26. The device of claim 17, wherein the deployment actuator has a concave or convex shape.
- 15 27. The device of claim 17, further comprising a storage chamber for receiving the substance that is received from the skin of the subject.
28. The device of claim 17, wherein the substance received from the skin of the  
20 subject comprises blood.
29. The device of claim 17, wherein the substance received from the skin of the subject comprises interstitial fluid.
- 25 30. A device for receiving a substance from the skin of a subject, and/or for delivering a substance to the skin of a subject, the device comprising:
- a substance transfer component for insertion into the skin of a subject, having a pre-deployed position and a deployed position; and
  - a deployment actuator able to move the substance transfer component  
30 from the pre-deployed position to the deployed position in a period of time of less than 0.002 seconds, and/or at a velocity of at least 6 meters/second when the

substance transfer component is positioned to first contact the skin during deployment,

and wherein the substance transfer component is constructed and arranged to deliver, to the skin of the subject, a substance selected from the group  
5 consisting of a peptide, a protein, a carbohydrate, a nucleoprotein, a mucoprotein, a lipoprotein, a glycoprotein, a nucleic acid, a nucleotide, nucleoside, a lipid, and a biologically active organic molecule.

31. The device of claim 30, wherein the substance transfer component includes a  
10 plurality of skin insertion objects.
32. The device of claim 31, wherein at least some of the skin insertion objects comprise needles.
- 15 33. The device of claim 31, wherein at least some of the skin insertion objects comprise microneedles.
34. The device of claim 31, wherein at least some of the skin insertion objects are at least partially coated with a substance arranged to be delivered to the subject  
20 when the skin insertion objects are inserted into the skin.
35. The device of claim 34, wherein the substance arranged to be delivered to the subject is selected from the group consisting of a peptide, a protein, a carbohydrate, a nucleoprotein, a mucoprotein, a lipoprotein, a glycoprotein, a  
25 nucleic acid, a nucleotide, nucleoside, a lipid, and a biologically active organic molecule.
36. The device of claim 34, wherein the substance is an analgesic.
- 30 37. The device of claim 36, wherein the analgesic comprises one or more of lidocaine, bupivacaine, and tetracaine.

38. The device of claim 31, wherein at least some of the skin insertion objects are hollow.
39. The device of claim 30, wherein the deployment actuator has a concave or  
5 convex shape.
40. A device for receiving a substance from the skin of a subject, and/or for delivering a substance to the skin of a subject, the device comprising:  
10 a substance transfer component for insertion into the skin of a subject, having a pre-deployed position and a deployed position; and  
a deployment actuator, operably linkable to the substance transfer component, wherein a maximum distance between the deployment actuator and the skin of the subject is no more than 10 mm,  
15 and wherein the substance transfer component is constructed and arranged to deliver, to the skin of the subject, a substance selected from the group consisting of a peptide, a protein, a carbohydrate, a nucleoprotein, a mucoprotein, a lipoprotein, a glycoprotein, a nucleic acid, a nucleotide, nucleoside, a lipid, and a biologically active organic molecule.  
20
41. The device of claim 40, wherein the substance transfer component includes a plurality of skin insertion objects.
42. The device of claim 41, wherein at least some of the skin insertion objects  
25 comprise needles.
43. The device of claim 41, wherein at least some of the skin insertion objects comprise microneedles.
- 30 44. The device of claim 41, wherein at least some of the skin insertion objects are at least partially coated with a substance arranged to be delivered to the subject when the skin insertion objects are inserted into the skin.

45. The device of claim 44, wherein the substance arranged to be delivered to the subject is selected from the group consisting of a peptide, a protein, a carbohydrate, a nucleoprotein, a mucoprotein, a lipoprotein, a glycoprotein, a nucleic acid, a nucleotide, nucleoside, a lipid, and a biologically active organic molecule.
46. The device of claim 44, wherein the substance is an analgesic.
47. The device of claim 46, wherein the analgesic comprises one or more of lidocaine, bupivacaine, and tetracaine.
48. The device of claim 41, wherein at least some of the skin insertion objects are hollow.
49. The device of claim 40, wherein the deployment actuator has a concave or convex shape.
50. A device for receiving a substance from the skin of a subject, and/or for delivering a substance to the skin of a subject, the device comprising:
- a substance transfer component for insertion into the skin of a subject, having a pre-deployed position and a deployed position; and
  - a deployment actuator, operably linkable to the substance transfer component,
- wherein the device comprises at least one of:
- a largest lateral dimension, parallel to the skin of the subject when the device is positioned to receive or deliver the substance, of no more than about 6 cm; or
  - a largest vertical dimension, extending from the skin of the subject when the device is positioned to receive or deliver a substance, of no more than about 1.5 cm, or
  - a mass of no more than about 25 grams, absent the substance,

and wherein the substance transfer component is constructed and arranged to deliver, to the skin of the subject, a substance selected from the group consisting of a peptide, a protein, a carbohydrate, a nucleoprotein, a mucoprotein, a lipoprotein, a glycoprotein, a nucleic acid, a nucleotide, nucleoside, a lipid, and a biologically active organic molecule.

5

51. The device of claim 50, wherein the substance transfer component includes a plurality of skin insertion objects.

10 52. The device of claim 51, wherein at least some of the skin insertion objects comprise needles.

53. The device of claim 51, wherein at least some of the skin insertion objects comprise microneedles.

15

54. The device of claim 51, wherein at least some of the skin insertion objects are at least partially coated with a substance arranged to be delivered to the subject when the skin insertion objects are inserted into the skin.

20 55. The device of claim 54, wherein the substance arranged to be delivered to the subject is selected from the group consisting of a peptide, a protein, a carbohydrate, a nucleoprotein, a mucoprotein, a lipoprotein, a glycoprotein, a nucleic acid, a nucleotide, nucleoside, a lipid, and a biologically active organic molecule.

25

56. The device of claim 54, wherein the substance is an analgesic.

57. The device of claim 56, wherein the analgesic comprises one or more of lidocaine, bupivacaine, and tetracaine.

30

58. The device of claim 51, wherein at least some of the skin insertion objects are hollow.

59. The device of claim 50, wherein the deployment actuator has a concave or convex shape.
60. A device for receiving a substance from the skin of a subject, and/or for  
5 delivering a substance to the skin of a subject, the device comprising:  
a substance transfer component for insertion into the skin of a subject,  
having a pre-deployed position and a deployed position; and  
a deployment actuator able to move the substance transfer component  
from the pre-deployed position to the deployed position at an average  
10 acceleration of at least 60,000 meters/second<sup>2</sup>.
61. The device of claim 60, wherein the substance transfer component is constructed  
and arranged to deliver, to the skin of the subject, a substance selected from the  
group consisting of a peptide, a protein, a carbohydrate, a nucleoprotein, a  
15 mucoprotein, a lipoprotein, a glycoprotein, a nucleic acid, a nucleotide,  
nucleoside, a lipid, and a biologically active organic molecule.
62. The device of claim 60, wherein the substance transfer component includes a  
plurality of skin insertion objects.  
20
63. The device of claim 62, wherein at least some of the skin insertion objects  
comprise needles.
64. The device of claim 62, wherein at least some of the skin insertion objects  
25 comprise microneedles.
65. The device of claim 62, wherein at least some of the skin insertion objects are at  
least partially coated with a substance arranged to be delivered to the subject  
when the skin insertion objects are inserted into the skin.  
30
66. The device of claim 65, wherein the substance arranged to be delivered to the  
subject is selected from the group consisting of a peptide, a protein, a

carbohydrate, a nucleoprotein, a mucoprotein, a lipoprotein, a glycoprotein, a nucleic acid, a nucleotide, nucleoside, a lipid, and a biologically active organic molecule.

- 5 67. The device of claim 65, wherein the substance is an analgesic.
68. The device of claim 67, wherein the analgesic comprises one or more of lidocaine, bupivacaine, and tetracaine.
- 10 69. The device of claim 62, wherein at least some of the skin insertion objects are hollow.
70. The device of claim 60, wherein the deployment actuator has a concave or convex shape.
- 15 71. A device for receiving a substance from the skin of a subject, and/or for delivering a substance to the skin of a subject, the device comprising:  
a substance transfer component for insertion into the skin of a subject, having a pre-deployed position and a deployed position; and  
a deployment actuator able to move the substance transfer component  
20 from a fully pre-deployed position to a fully deployed position, wherein the distance between the fully pre-deployed position to the fully deployed position is no more than 5,000 microns,  
and wherein the substance transfer component is constructed and arranged to deliver, to the skin of the subject, a substance selected from the group  
25 consisting of a peptide, a protein, a carbohydrate, a nucleoprotein, a mucoprotein, a lipoprotein, a glycoprotein, a nucleic acid, a nucleotide, nucleoside, a lipid, and a biologically active organic molecule.
72. The device of claim 71, wherein the substance transfer component includes a  
30 plurality of skin insertion objects.



73. The device of claim 72, wherein at least some of the skin insertion objects comprise needles.
74. The device of claim 72, wherein at least some of the skin insertion objects  
5 comprise microneedles.
75. The device of claim 72, wherein at least some of the skin insertion objects are at least partially coated with a substance arranged to be delivered to the subject when the skin insertion objects are inserted into the skin.  
10
76. The device of claim 75, wherein the substance arranged to be delivered to the subject is selected from the group consisting of a peptide, a protein, a carbohydrate, a nucleoprotein, a mucoprotein, a lipoprotein, a glycoprotein, a nucleic acid, a nucleotide, nucleoside, a lipid, and a biologically active organic  
15 molecule.
77. The device of claim 75, wherein the substance is an analgesic.
78. The device of claim 77, wherein the analgesic comprises one or more of  
20 lidocaine, bupivacaine, and tetracaine.
79. The device of claim 72, wherein at least some of the skin insertion objects are hollow.
80. The device of claim 71, wherein the deployment actuator has a concave or  
25 convex shape.
81. A device for receiving a substance from the skin of a subject, and/or for delivering a substance to the skin of a subject, the device comprising:  
30 a substance transfer component including a plurality of skin insertion objects for insertion into the skin of a subject, having a pre-deployed position and a deployed position, each of the skin insertion objects protruding from a base and defining a length from the base, and the plurality of skin insertion objects

defining an average length of no more than 1,500 microns; and

a deployment actuator able to move the skin insertion objects from a fully pre-deployed position to a fully deployed position with a force sufficient to insert the plurality of skin insertion objects into or through the skin to an average  
5 insertion depth of at least 60% the average length of the plurality of skin insertion objects,

and wherein the substance transfer component is constructed and arranged to deliver, to the skin of the subject, a substance selected from the group consisting of a peptide, a protein, a carbohydrate, a nucleoprotein, a mucoprotein,  
10 a lipoprotein, a glycoprotein, a nucleic acid, a nucleotide, nucleoside, a lipid, and a biologically active organic molecule.

82. The device of claim 81, wherein at least some of the skin insertion objects comprise needles.

83. The device of claim 81, wherein at least some of the skin insertion objects comprise microneedles.

84. The device of claim 81, wherein at least some of the skin insertion objects are at least partially coated with a substance arranged to be delivered to the subject  
20 when the skin insertion objects are inserted into the skin.

85. The device of claim 84, wherein the substance arranged to be delivered to the subject is selected from the group consisting of a peptide, a protein, a  
25 carbohydrate, a nucleoprotein, a mucoprotein, a lipoprotein, a glycoprotein, a nucleic acid, a nucleotide, nucleoside, a lipid, and a biologically active organic molecule.

86. The device of claim 84, wherein the substance is an analgesic.

87. The device of claim 86, wherein the analgesic comprises one or more of lidocaine, bupivacaine, and tetracaine.

88. The device of claim 81, wherein at least some of the skin insertion objects are hollow.
- 5 89. The device of claim 81, wherein the average insertion depth is at least 70% the average length of the plurality of skin insertion objects.
90. The device of claim 81, wherein the average insertion depth is at least 80% the average length of the plurality of skin insertion objects.
- 10 91. The device of claim 81, wherein the average insertion depth is at least 90% the average length of the plurality of skin insertion objects.
92. A device as in any one of claims 81-91, comprising at least 3 but no more than 5  
15 skin insertion objects.
93. A device as in any one of claims 81-91, comprising at least 6 but no more than 10 skin insertion objects.
- 20 94. A device as in any one of claims 81-91, comprising at least 11 but no more than 27 skin insertion objects.
95. A device for receiving a substance from the skin of a subject, and/or for delivering a substance to the skin of a subject, the device comprising:
- 25 a substance transfer component including a plurality of skin insertion objects for insertion into the skin of a subject, having a pre-deployed position and a deployed position; and
- a deployment actuator, operably linkable to the plurality of skin insertion objects, the deployment actuator switchable from a stored energy position to a  
30 deployed energy position, wherein the stored energy position is associated with the pre-deployed position of the skin insertion objects, and the deployed energy position is associated with the deployed position of the skin insertion objects,

and wherein the substance transfer component is constructed and arranged to deliver, to the skin of the subject, a substance selected from the group consisting of a peptide, a protein, a carbohydrate, a nucleoprotein, a mucoprotein, a lipoprotein, a glycoprotein, a nucleic acid, a nucleotide, nucleoside, a lipid, and a biologically active organic molecule.

5

96. The device of claim 95, wherein the substance transfer component includes a plurality of skin insertion objects.

10 97. The device of claim 96, wherein at least some of the skin insertion objects comprise needles.

98. The device of claim 96, wherein at least some of the skin insertion objects comprise microneedles.

15

99. The device of claim 96, wherein at least some of the skin insertion objects are at least partially coated with a substance arranged to be delivered to the subject when the skin insertion objects are inserted into the skin.

20 100. The device of claim 99, wherein the substance arranged to be delivered to the subject is selected from the group consisting of a peptide, a protein, a carbohydrate, a nucleoprotein, a mucoprotein, a lipoprotein, a glycoprotein, a nucleic acid, a nucleotide, nucleoside, a lipid, and a biologically active organic molecule.

25

101. The device of claim 99, wherein the substance is an analgesic.

102. The device of claim 101, wherein the analgesic comprises one or more of lidocaine, bupivacaine, and tetracaine.

30

103. The device of claim 96, wherein at least some of the skin insertion objects are hollow.

104. A device as in claim 95, wherein the stored energy position of the deployment actuator is a cocked position and is at a higher energy level than the deployed energy position, wherein urging the structure from the stored energy position to the deployed energy position causes the structure to rapidly move to the deployed energy position.
105. The device of claim 95, wherein the deployment actuator has a concave or a convex shape.
106. A device for delivering a substance to the skin of a subject, the device comprising:
- a substance transfer component for insertion into the skin of a subject, having a pre-deployed position and a deployed position; and
  - a deployment actuator, operably linkable to the substance transfer component, the deployment actuator switchable from a first stable configuration, through an unstable configuration, to a second stable configuration, wherein in the first stable configuration, the substance transfer component is not contactable with the skin of the subject, and in the second stable configuration, the substance transfer component is insertable in the skin of the subject,
- and wherein the substance transfer component is constructed and arranged to deliver, to the skin of the subject, a substance selected from the group consisting of a peptide, a protein, a carbohydrate, a nucleoprotein, a mucoprotein, a lipoprotein, a glycoprotein, a nucleic acid, a nucleotide, nucleoside, a lipid, and a biologically active organic molecule.
107. The device of claim 106, wherein the substance transfer component includes a plurality of skin insertion objects.
108. The device of claim 107, wherein at least some of the skin insertion objects comprise needles.

109. The device of claim 107, wherein at least some of the skin insertion objects  
comprise microneedles.
110. The device of claim 107, wherein at least some of the skin insertion objects are at  
5 least partially coated with a substance arranged to be delivered to the subject  
when the skin insertion objects are inserted into the skin.
111. The device of claim 110, wherein the substance arranged to be delivered to the  
subject is selected from the group consisting of a peptide, a protein, a  
10 carbohydrate, a nucleoprotein, a mucoprotein, a lipoprotein, a glycoprotein, a  
nucleic acid, a nucleotide, nucleoside, a lipid, and a biologically active organic  
molecule.
112. The device of claim 110, wherein the substance is an analgesic.  
15
113. The device of claim 112, wherein the analgesic comprises one or more of  
lidocaine, bupivacaine, and tetracaine.
114. The device of claim 107, wherein at least some of the skin insertion objects are  
20 hollow.
115. The device of claim 106, wherein the deployment actuator has a concave or a  
convex shape.

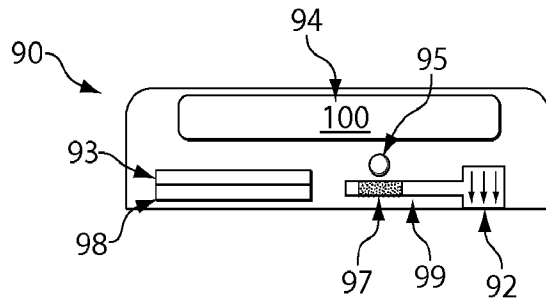

Fig. 1A

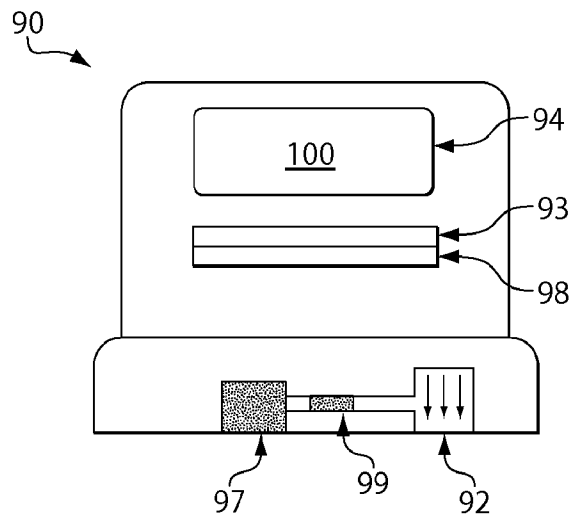

Fig. 1B

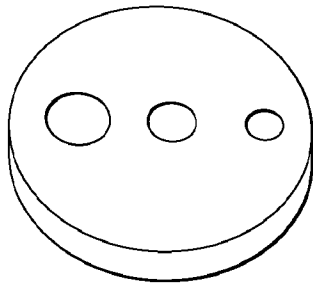

Fig. 2A

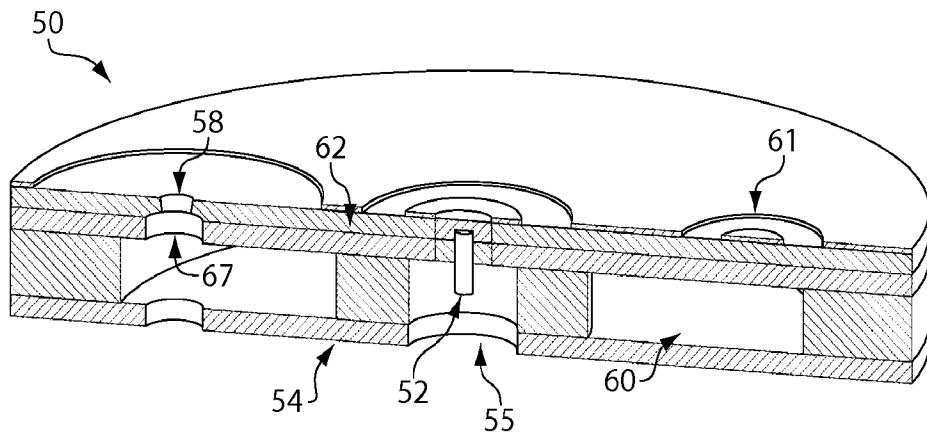

Fig. 2B

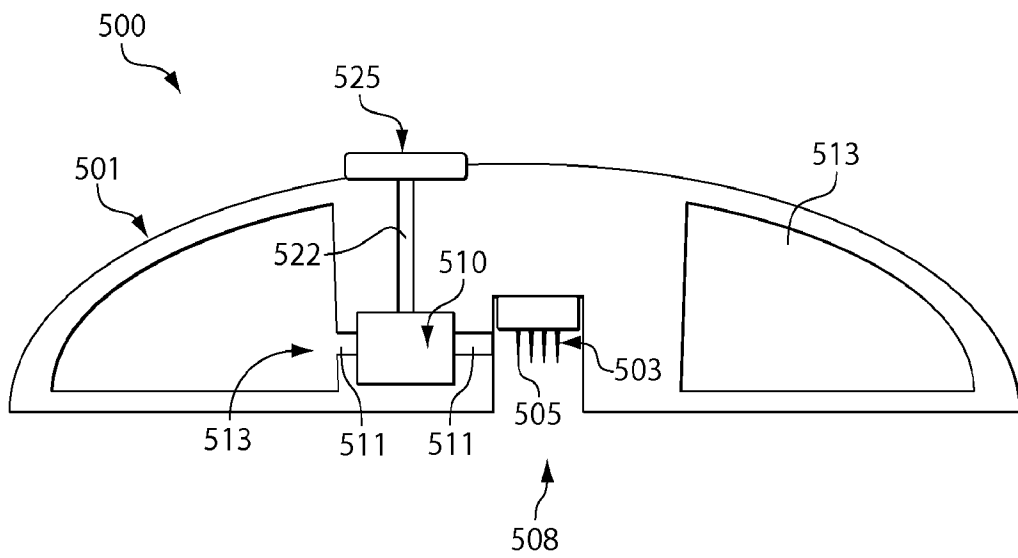

Fig. 2C



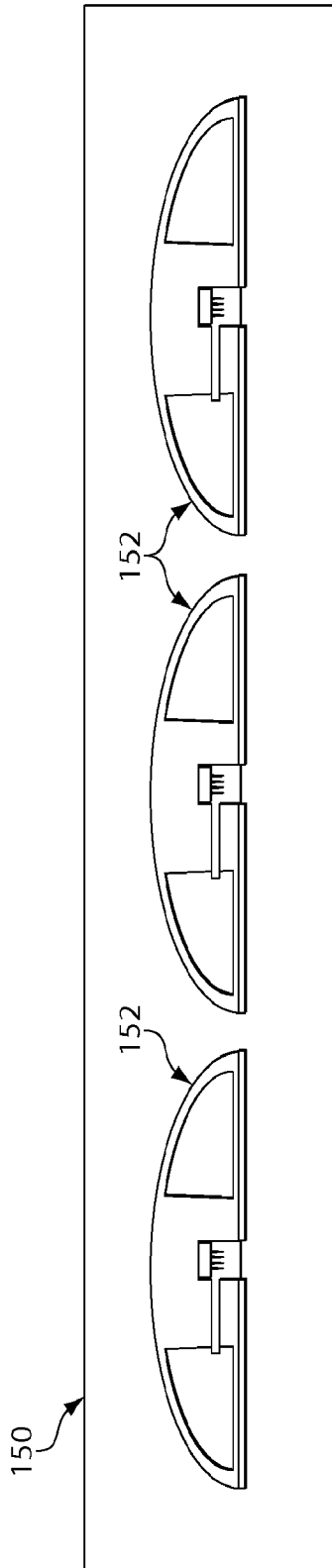

Fig. 2D

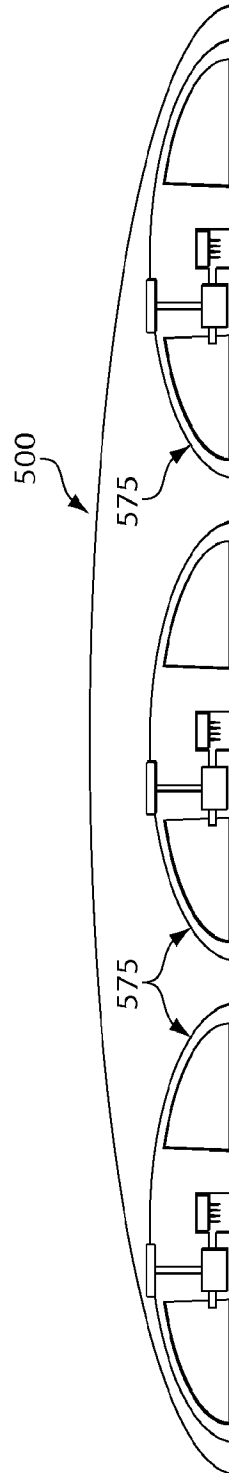

Fig. 2E

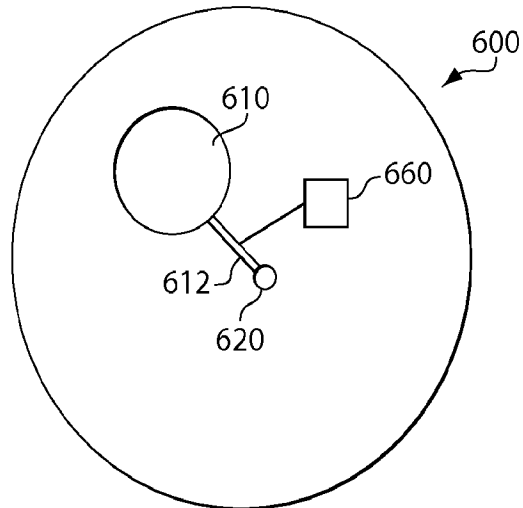

Fig. 3

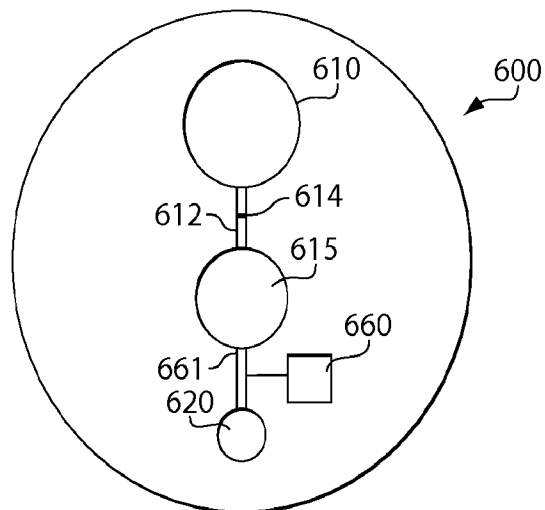

Fig. 4

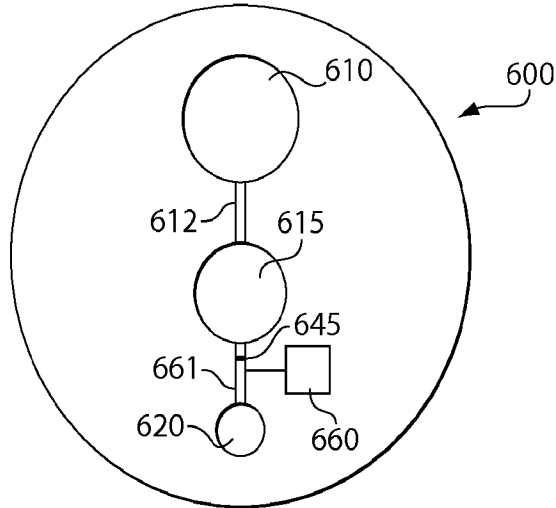

Fig. 5

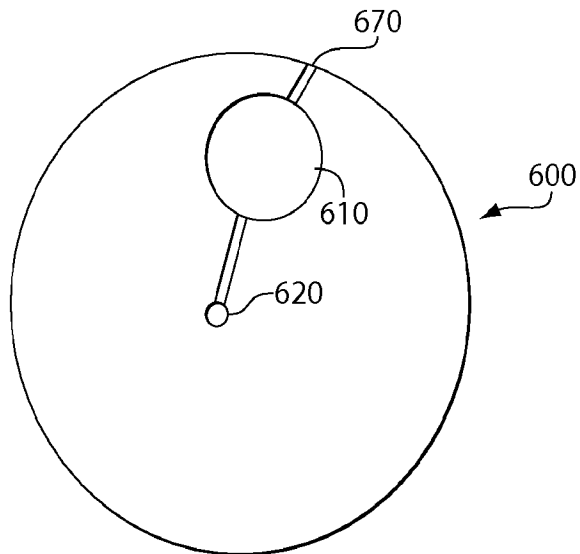

Fig. 6

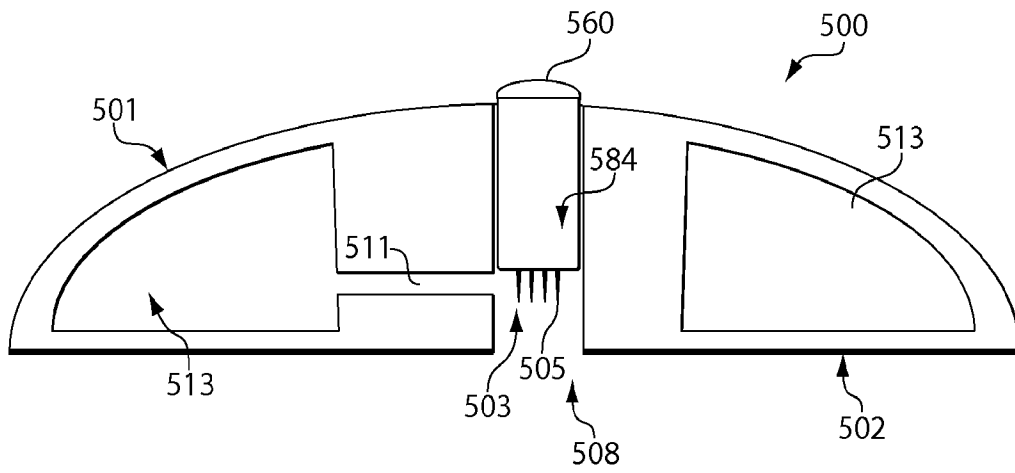

Fig. 7

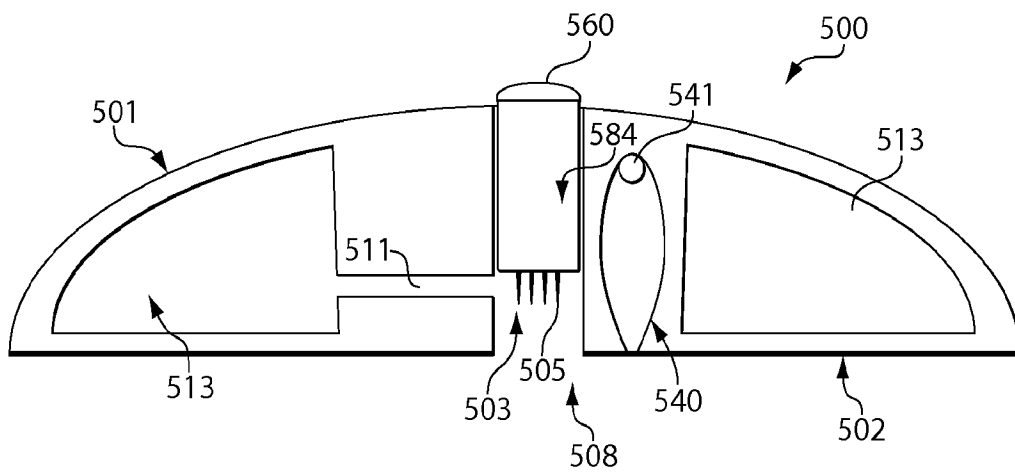

Fig. 8

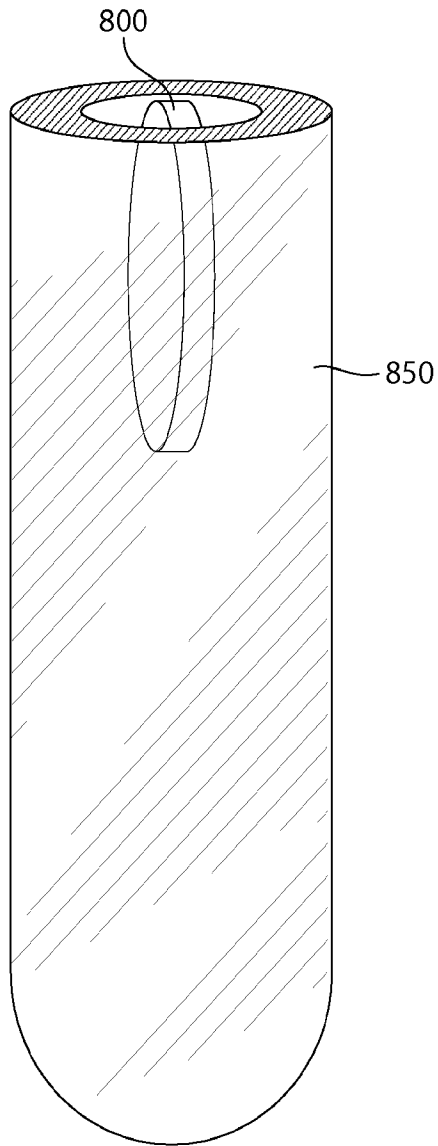

Fig. 9

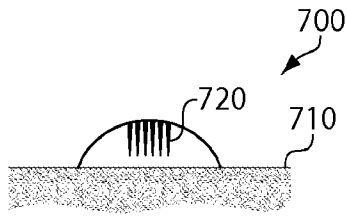

Fig. 10A

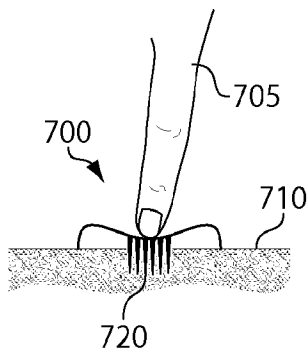

Fig. 10B

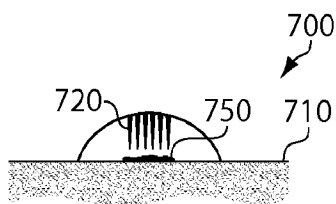

Fig. 10C

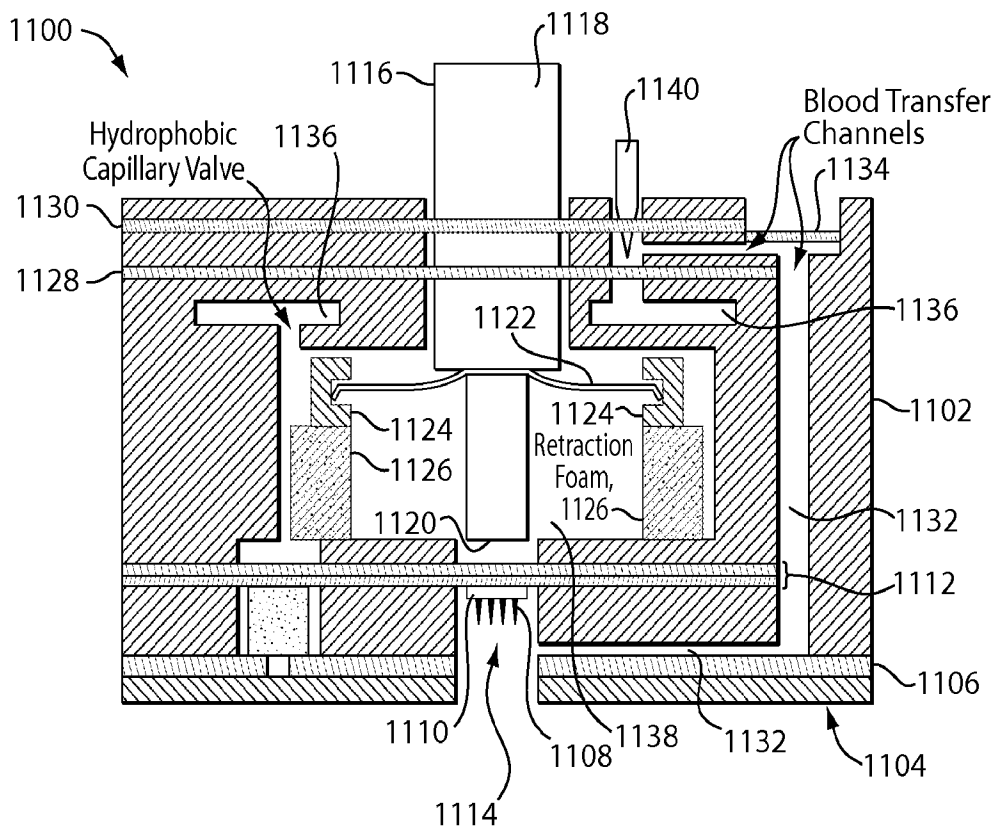

Fig. 11

10/13

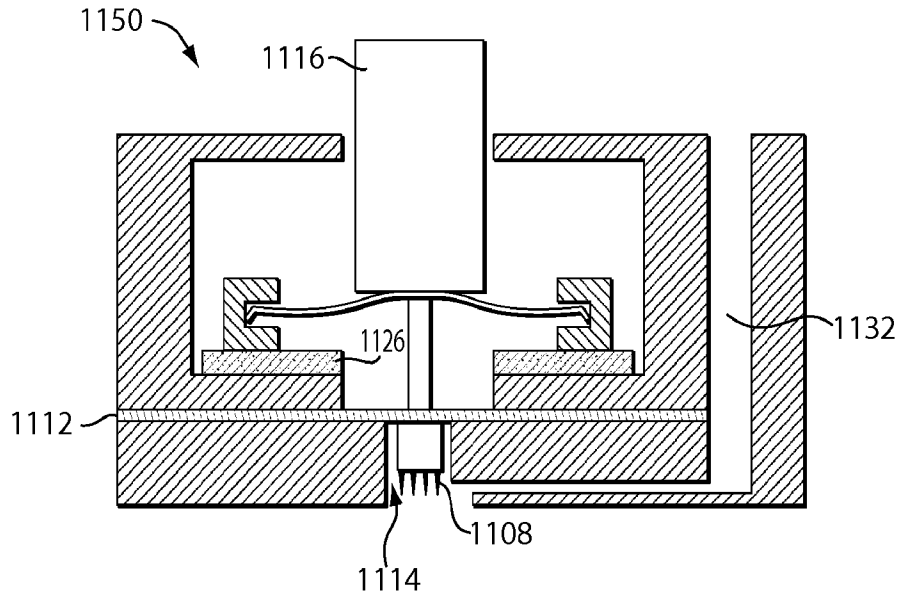

Fig. 12A

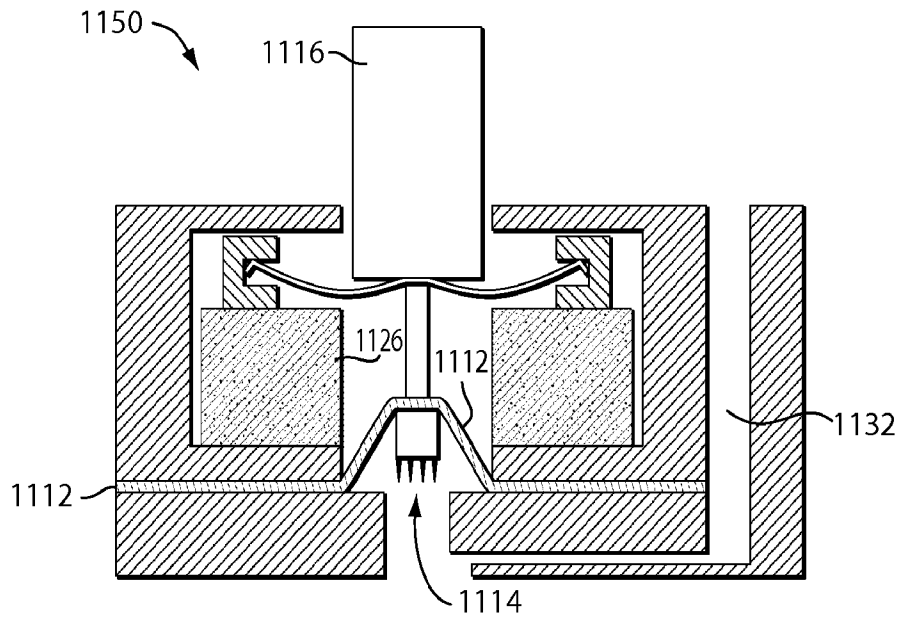

Fig. 12B



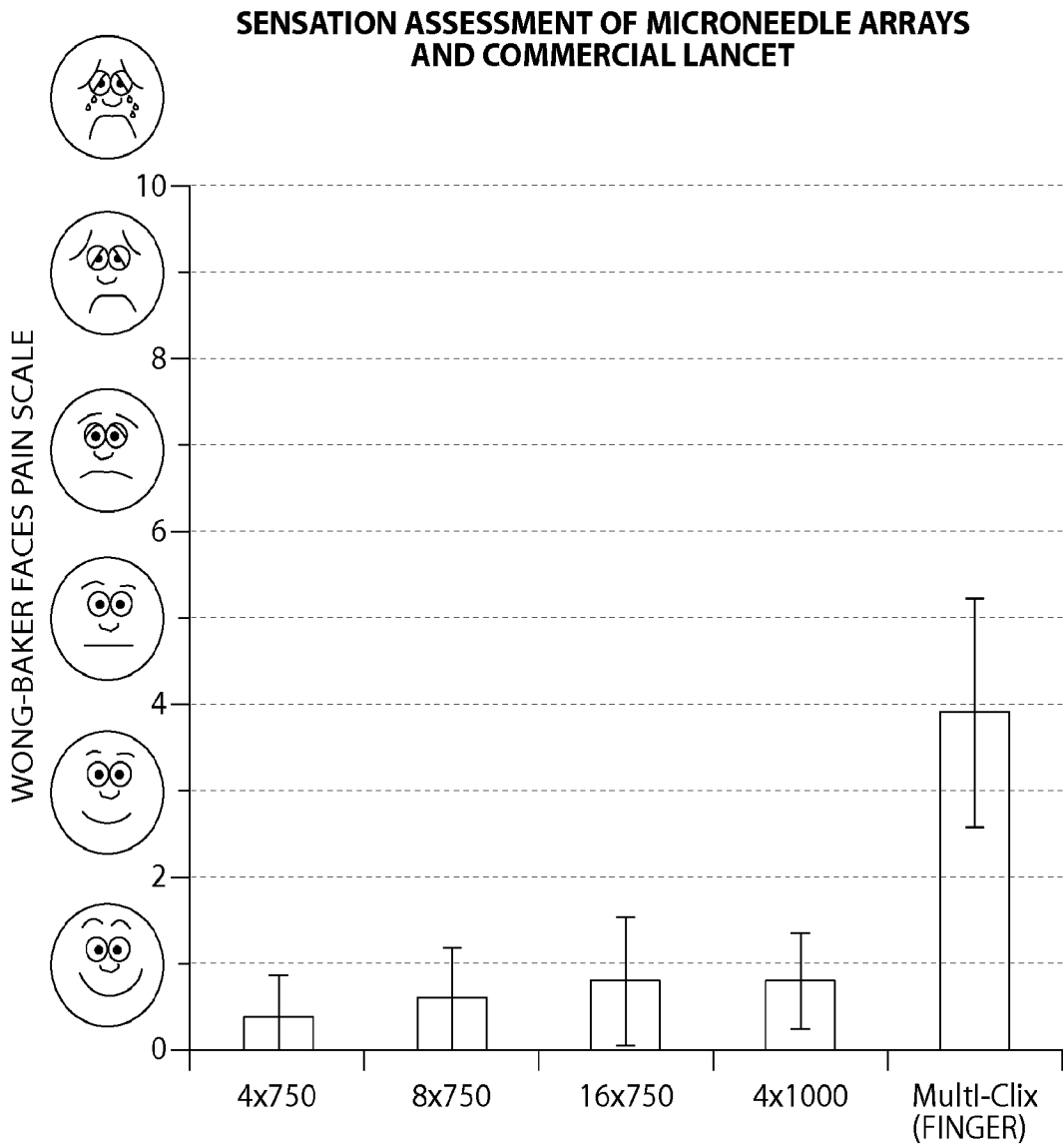

Fig. 13

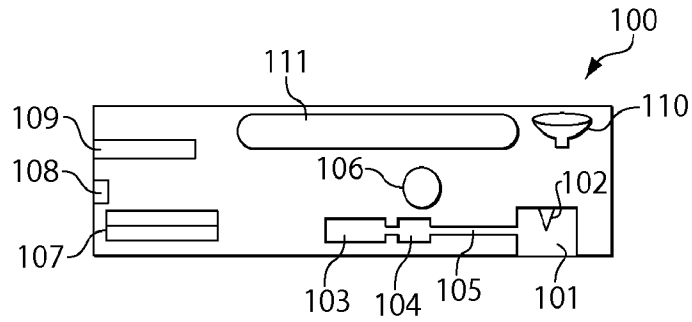

Fig. 14A

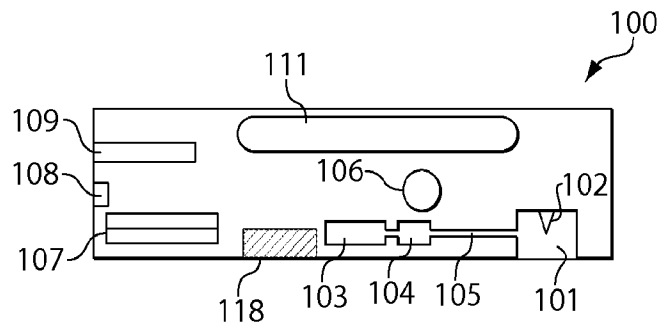

Fig. 14B

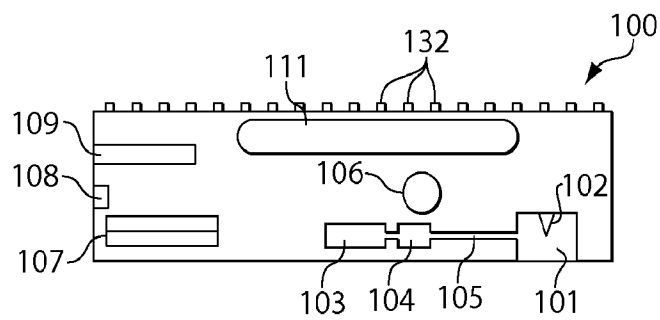

Fig. 14C

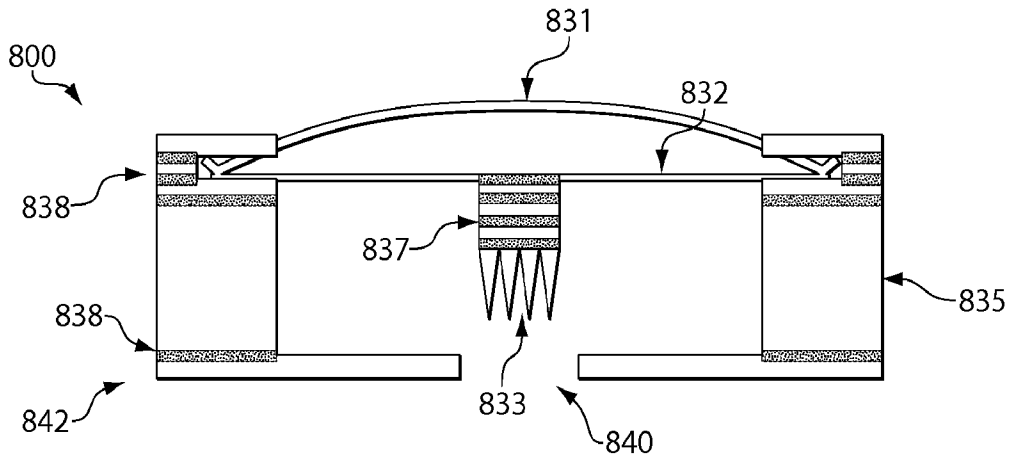

Fig. 15A

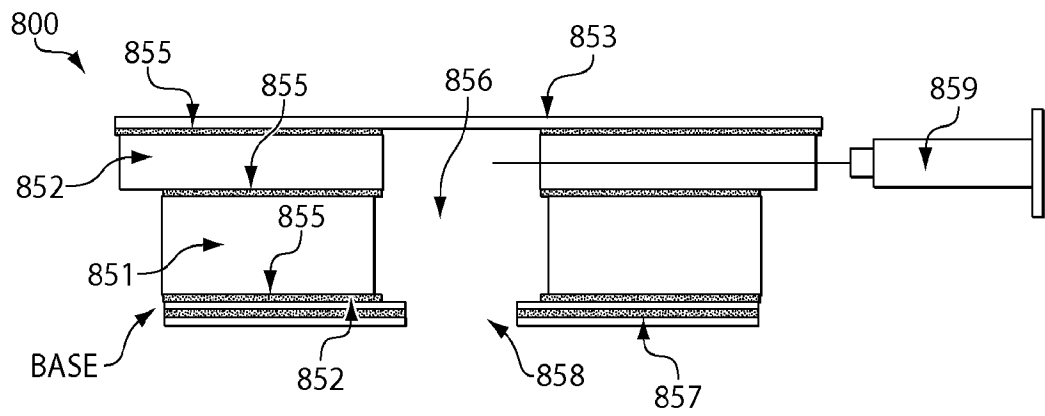

Fig. 15B

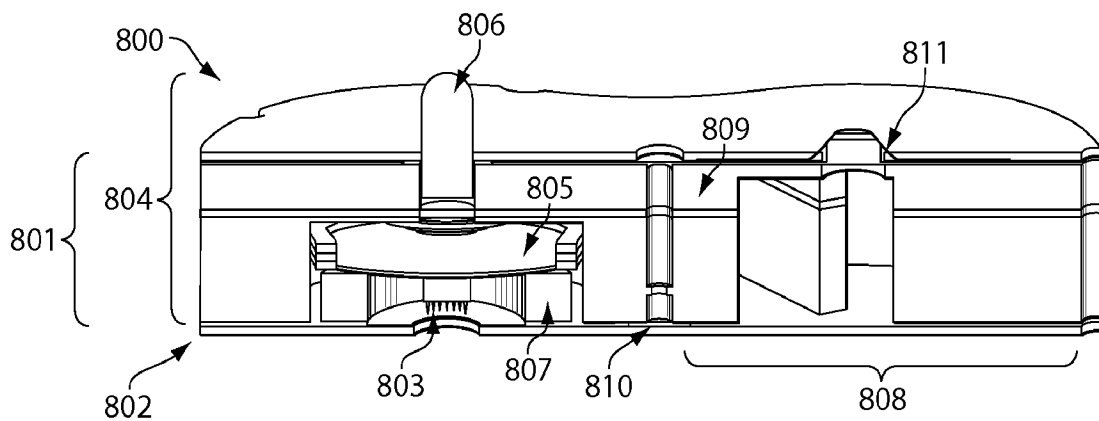

Fig. 15C