

*J. Richey*

*Lubricator.*

*N<sup>o</sup> 79,501. Patented June 30, 1868.*

*Fig. 1.*

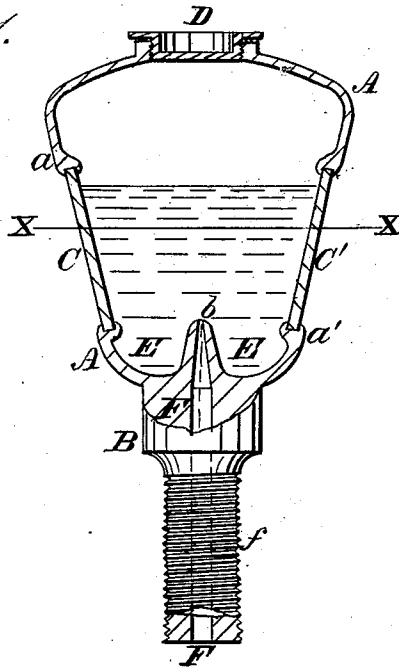

*Fig. 2.*

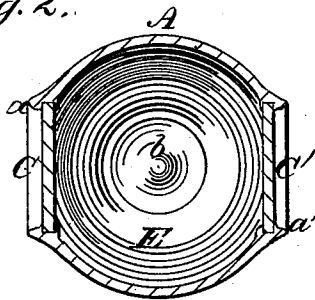

*Witnesses.*  
*Chas Bauer*  
*W. G. Weber*

*Inventor.*  
*James Richey*  
*By Knight Bros Attys*

# United States Patent Office.

JAMES RICHEY, OF CINCINNATI, OHIO.

Letters Patent No. 79,501, dated June 30, 1868; antedated April 10, 1868.

## IMPROVEMENT IN LUBRICATORS.

The Schedule referred to in these Letters Patent and making part of the same.

### TO WHOM IT MAY CONCERN:

Be it known that I, JAMES RICHEY, of Cincinnati, Hamilton county, Ohio, have invented a new and useful Lubricator; and I hereby declare the following to be a full, clear, and exact description thereof, reference being had to the accompanying drawings, making part of this specification.

My invention relates to that class of devices which are employed for the lubrication of journal-bearings &c.; and the first part of my improvement consists in forming the oil-reservoir, and the stem by which the lubricator is attached to the journal-box, of a single piece of metal, thereby producing a perfectly reliable and air-tight article.

The second part of my improvements consists in providing the oil-reservoir with glass or other transparent windows, by which means the amount of oil in said reservoir can be seen at a glance.

The third part of my improvement relates to a sediment-chamber, which is located at the bottom of the oil-reservoir, for the purpose of collecting any impurities that may be precipitated from the oil.

In the accompanying drawings—

Figure 1 is an axial section of a lubricator embodying my improvements, a portion of the stem being shown in elevation, to exhibit its external screw-thread.

Figure 2 is a horizontal section of the same, taken at the line *x x*.

My lubricator consists essentially of an oil-reservoir, A, and stem B, which are formed of a single piece of Britannia or any other easily-fusible metal. The sides of the reservoir are furnished with glass or other transparent windows, C C', the windows being secured to the reservoir by pre-heating and casting the material of the latter about them.

The openings in which the windows are inserted are provided with outwardly-projecting ridges *a a'*, which not only stiffen the oil-reservoir, but also serve to protect the windows from injury.

The upper part of the reservoir is provided with a screw-threaded cap, D, which, being removed, allows the reservoir to be filled.

The stem B projects upwardly a slight distance from the bottom of the oil-reservoir, as shown at *b*, so as to form a sediment-chamber, E, between said projection and the sides and bottom of the reservoir.

The interior of the stem B is provided with a longitudinal channel, F, down which the oil flows from the chamber to the shaft which is to be lubricated, and the outside of the stem is screw-threaded at *f*, so as to permit of the apparatus being secured to the journal-box.

The oil-reservoir and stem being formed of a single piece of metal, obviates the necessity of a joint between them, which must always be the case when these two members are made of separate pieces, and it will be seen that by omitting said joint I dispense with a very objectionable feature peculiar to all of the lubricators which have been constructed, it being well known that a leak between the stem and reservoir will impair if not entirely destroy the efficiency of these devices.

The provision of the windows C C' enables the attendant to observe the stage of oil in the reservoir, so that he can replenish it before it becomes entirely empty. The stem B being prolonged at *b* so as to project above the bottom of the reservoir, prevents the channel F being clogged up by any impurities contained in the oil, as these will collect in the sediment-chamber, from which they can be readily removed as occasion requires.

I claim herein as new and of my invention—

A lubricator, with its oil-reservoir A cast in one piece with the stem B, and furnished with windows C C', all substantially in the manner herein described and for the purposes specified.

In testimony of which invention, I hereunto set my hand.

JAMES RICHEY.

Witnesses:

GEO. H. KNIGHT,  
JAMES H. LAYMAN.