

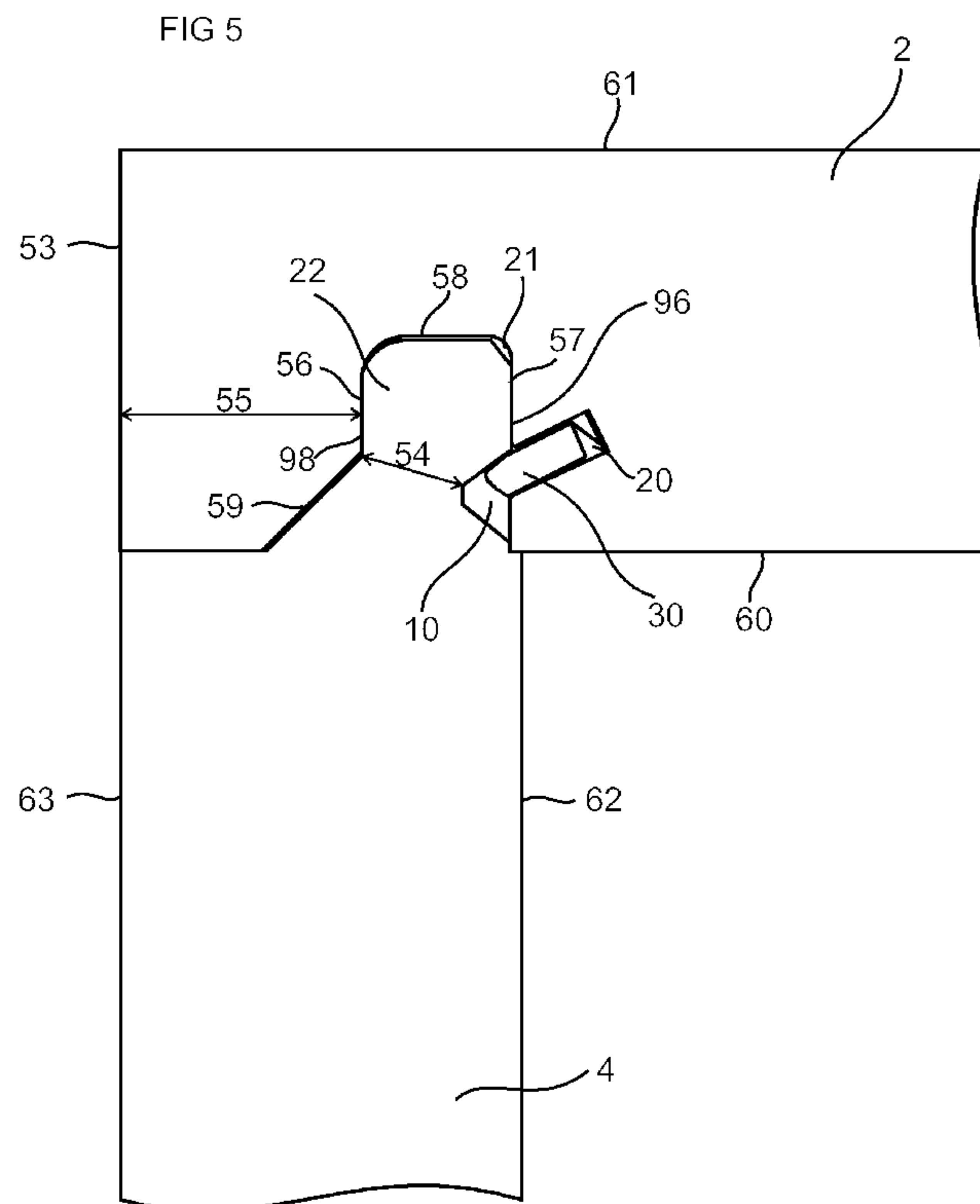

(86) **Date de dépôt PCT/PCT Filing Date:** 2014/12/17
 (87) **Date publication PCT/PCT Publication Date:** 2015/07/16
 (85) **Entrée phase nationale/National Entry:** 2016/06/07
 (86) **N° demande PCT/PCT Application No.:** SE 2014/051521
 (87) **N° publication PCT/PCT Publication No.:** 2015/105449
 (30) **Priorité/Priority:** 2014/01/10 (SE1450022-7)

(51) **Cl.Int./Int.Cl. F16B 12/10** (2006.01),
A47B 47/00 (2006.01)
 (71) **Demandeur/Applicant:**
VALINGE INNOVATION AB, SE
 (72) **Inventeur/Inventor:**
DERELOV, PETER, SE
 (74) **Agent:** FETHERSTONHAUGH & CO.

(54) **Titre : PANNEAUX COMPRENANT UN DISPOSITIF DE VERROUILLAGE MECANIQUE ET PRODUIT ASSEMBLE
COMPRENANT CES PANNEAUX**
 (54) **Title: PANELS COMPRISING A MECHANICAL LOCKING DEVICE AND AN ASSEMBLED PRODUCT COMPRISING THE
PANELS**



(57) **Abrégé/Abstract:**

A set of panels includes a first panel 2 having a first main plane and a second panel 4 having a second main plane. The panels are provided with a mechanical locking device for locking a first edge of the first panel 2 to a second edge of the second pane l4. The

(57) Abrégé(suite)/Abstract(continued):

mechanical locking device includes an edge section groove 21 at the first edge, wherein an edge section 22 of the second edge is insertable into the edge section groove. A flexible tongue 30 is arranged in an insertion groove 20 provided in the edge section groove 22, and cooperates with a tongue groove 10 provided at the edge section 22 of the second panel. A first thickness 55 of a core material between the edge section groove 21 and the outermost surface of the first edge is greater than a minimum second thickness 4 of a core material of the edge section 22 of the second panel.

(12) INTERNATIONAL APPLICATION PUBLISHED UNDER THE PATENT COOPERATION TREATY (PCT)

(19) World Intellectual Property
Organization
International Bureau(10) International Publication Number
WO 2015/105449 A1(43) International Publication Date
16 July 2015 (16.07.2015)

(51) International Patent Classification:

F16B 12/10 (2006.01) A47B 47/00 (2006.01)

(21) International Application Number:

PCT/SE2014/051521

(22) International Filing Date:

17 December 2014 (17.12.2014)

(25) Filing Language:

English

(26) Publication Language:

English

(30) Priority Data:

1450022-7 10 January 2014 (10.01.2014) SE

(71) Applicant: VÄLINGE INNOVATION AB [SE/SE];
Prästavägen 513, SE-263 65 Viken (SE).(72) Inventor: DERELÖV, Peter; Lärkvägen 4 A, S-252 84
Helsingborg (SE).(74) Agent: ENGSTRAND, Ola; Välinge Innovation AB,
Prästavägen 513, SE-263 65 Viken (SE).(81) Designated States (unless otherwise indicated, for every
kind of national protection available): AE, AG, AL, AM,
AO, AT, AU, AZ, BA, BB, BG, BH, BN, BR, BW, BY,
BZ, CA, CH, CL, CN, CO, CR, CU, CZ, DE, DK, DM,
DO, DZ, EC, EE, EG, ES, FI, GB, GD, GE, GH, GM, GT,
HN, HR, HU, ID, IL, IN, IR, IS, JP, KE, KG, KN, KP, KR,
KZ, LA, LC, LK, LR, LS, LU, LY, MA, MD, ME, MG,
MK, MN, MW, MX, MY, MZ, NA, NG, NI, NO, NZ, OM,
PA, PE, PG, PH, PL, PT, QA, RO, RS, RU, RW, SA, SC,
SD, SE, SG, SK, SL, SM, ST, SV, SY, TH, TJ, TM, TN,
TR, TT, TZ, UA, UG, US, UZ, VC, VN, ZA, ZM, ZW.(84) Designated States (unless otherwise indicated, for every
kind of regional protection available): ARIPO (BW, GH,
GM, KE, LR, LS, MW, MZ, NA, RW, SD, SL, ST, SZ,
TZ, UG, ZM, ZW), Eurasian (AM, AZ, BY, KG, KZ, RU,
TJ, TM), European (AL, AT, BE, BG, CH, CY, CZ, DE,
DK, EE, ES, FI, FR, GB, GR, HR, HU, IE, IS, IT, LT, LU,
LV, MC, MK, MT, NL, NO, PL, PT, RO, RS, SE, SI, SK,
SM, TR), OAPI (BF, BJ, CF, CG, CI, CM, GA, GN, GQ,
GW, KM, ML, MR, NE, SN, TD, TG).

[Continued on next page]

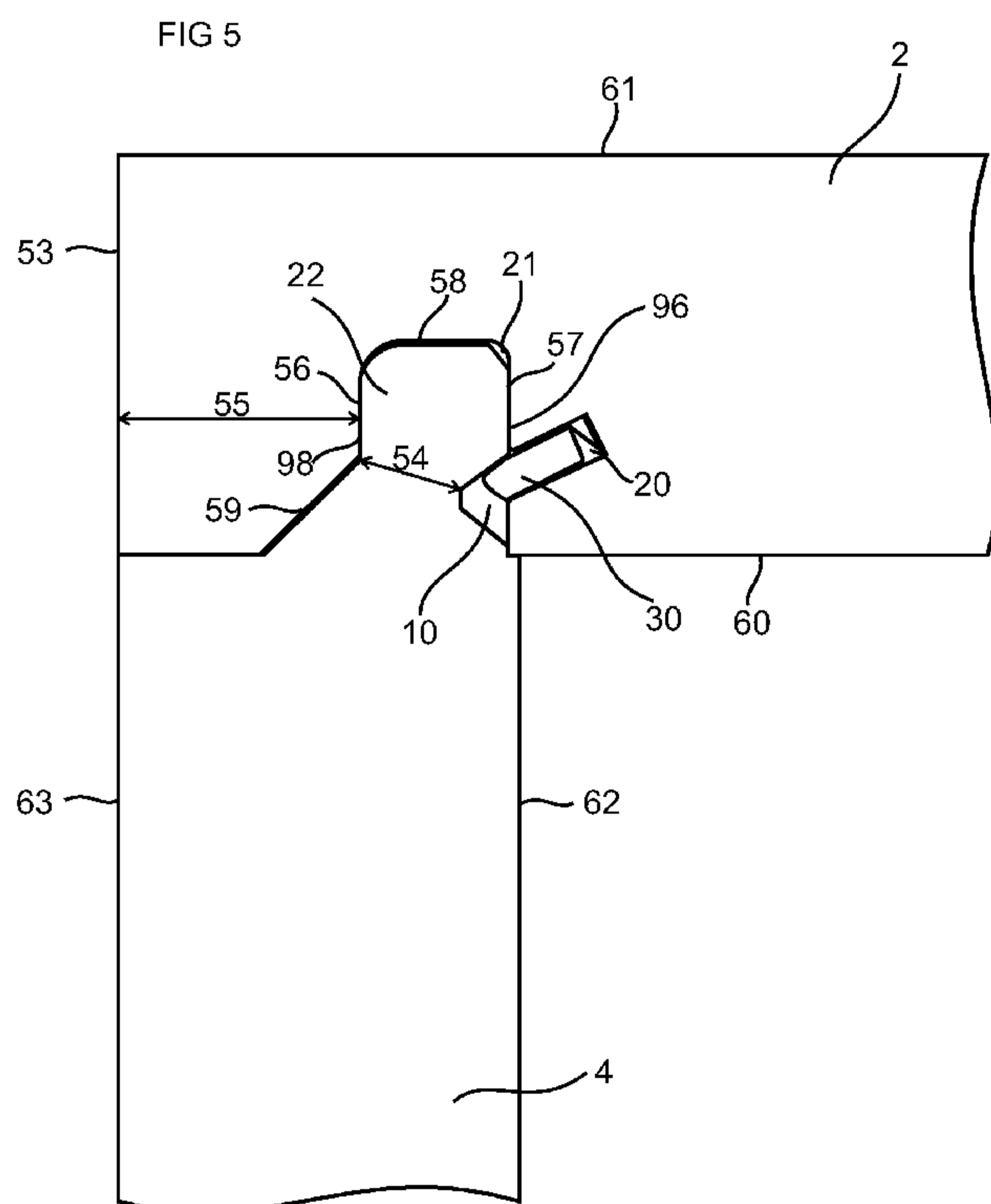
(54) Title: PANELS COMPRISING A MECHANICAL LOCKING DEVICE AND AN ASSEMBLED PRODUCT COMPRISING
THE PANELS(57) Abstract: A set of panels includes a first panel 2 having
a first main plane and a second panel 4 having a second
main plane. The panels are provided with a mechanical lock-
ing device for locking a first edge of the first panel 2 to a
second edge of the second panel 4. The mechanical locking
device includes an edge section groove 21 at the first edge,
wherein an edge section 22 of the second edge is insertable
into the edge section groove. A flexible tongue 30 is ar-
ranged in an insertion groove 20 provided in the edge sec-
tion groove 22, and cooperates with a tongue groove 10
provided at the edge section 22 of the second panel. A first
thickness 55 of a core material between the edge section
groove 21 and the outermost surface of the first edge is
greater than a minimum second thickness 4 of a core materi-
al of the edge section 22 of the second panel.

WO 2015/105449 A1 

Declarations under Rule 4.17:

— *as to applicant's entitlement to apply for and be granted a patent (Rule 4.17(ii))*

Published:

— *with international search report (Art. 21(3))*

PANELS COMPRISING A MECHANICAL LOCKING DEVICE AND AN
ASSEMBLED PRODUCT COMPRISING THE PANELS

Technical Field

The present invention relates to panels that may be arranged perpendicular to each other
5 and locked together with a mechanical locking device. The panels may be assembled and
locked together to obtain a furniture, such as a bookshelf, a cupboard, a wardrobe, a box,
a drawer or a furniture component. The locking device may comprise a flexible tongue.

Background

A furniture provided with a mechanical locking device is known in the art, as evidenced
10 by WO2012154113(A1). The furniture comprises a first panel connected perpendicular
to a second panel by a mechanical locking device comprising a flexible tongue in an
insertion groove.

Summary

One object of certain embodiments of the present invention to provide an improvement
15 over the above described technique and the known art. A specific objective is to improve
the strength of a mechanical locking device at a corner of an assembled product, such as
a furniture, a furniture component, a drawer, a cupboard, a bookshelf, a wardrobe, a
kitchen fixture, or a box for storing or transporting.

A further object of embodiments of the invention is to provide a furniture product with
20 increased strength and stability.

At least some of these and other objects and advantages that will be apparent from the
description have been achieved by a set of panels comprising a first panel having a first
main plane and a second panel having a second main plane. The first panel and the
second panel are provided with a mechanical locking device for locking a first edge of
25 the first panel to a second edge of the second panel, wherein the first main plane is
essentially perpendicular to the second main plane. The first panel comprises a core
comprising fibres arranged essentially parallel to the first main plane and the second
panel comprises a core comprising fibres arranged essentially parallel to the second main
plane. The mechanical locking device comprises:

30 an edge section groove at the first edge, wherein an edge section of the second
edge of the second panel is insertable into the edge section groove for locking the

first panel and the second panel together in a first direction parallel to the first main plane; and

5 a flexible tongue arranged in an insertion groove provided in the edge section groove of the first edge, wherein said flexible tongue cooperates with a tongue groove arranged at the edge section of the second edge of the second panel, for locking the first panel and the second panel in a second direction parallel to the second main plane.

10 A first thickness of a core material of the first panel between the edge section groove and the outermost surface of the first edge in a direction parallel to the first main plane is greater than a minimum second thickness of a core material of the edge section of the second edge of the second panel. Further, a first thickness of the first panel between the edge section groove and the outermost surface of the first edge in a direction parallel to the first main plane may be greater than a minimum second thickness of the edge section of the second edge of the second panel.

15 The mechanical locking device may be subject to the greatest stress in the first direction parallel to the first main plane. The stress in the first direction may arise from a pressure load applied on the side panel at the top of a furniture, such as a bookshelf, a cupboard or a wardrobe. The minimum second thickness may be rather thin since the edge section of the second edge of the second panel has the fibre direction essentially perpendicular to the stress in the first direction. The first thickness is preferably greater than the minimum second distance because the fibre direction of the edge section groove of the first panel is essentially parallel to the stress in the first direction. The stress in the first direction may also arise before the first panel and the second panel are assembled and locked together, for example, during transport, production or during an assembling and locking of the first panel and the second panel.

20 The first thickness ranges from between 1,1 and 3,0 times larger than the minimum second thickness, and may be at least about 1,25 times larger; preferably about 1,5 time larger; and more preferably about 2,0 times larger than the minimum second thickness.

30 The first direction is preferably perpendicular to the first edge of the first panel and second direction is preferably perpendicular to the second edge of the second panel.

The flexible tongue may alternatively be arranged in an insertion groove in the edge section of the second edge of the second panel, and the tongue groove may be arranged

in edge section groove of the first edge of the first panel. However, a greater size of the insertion groove, as compared to the tongue groove, may be required. Therefore, the alternative with the insertion groove in the edge section groove of the first panel may be the preferred alternative.

- 5 The edge section groove may comprise a first wall and an opposed second wall, wherein the first wall is closer to the outermost surface of the first edge than the second wall, wherein the first thickness is measured between the first wall and the outermost surface of the first edge.

10 The insertion groove may extend along essentially the entire length of the edge section groove of the first edge.

The tongue groove may extend along essentially the entire length of the edge section of second panel.

15 The edge section of the second panel may also comprise two or more insertion grooves and/or flexible tongues. The edge section of the first edge may comprise two or more tongue grooves.

The edge section groove may extend along essentially the whole first edge, and is preferably covered by e.g. a decorative layer, such as plastic foil or a veneer, at a front edge of the first panel and may also be covered at a back edge of the first panel. A length of the edge section of the second edge (measured along the second edge) preferably matches a length of the edge section groove (measured along the first edge). The second panel may be provided with at least one dismantling groove at an inner or outer face of the second panel. The embodiment of the first panel that is provided with the edge section groove that is covered by e.g. a decorative layer, such as plastic foil or a veneer at the back and the front edge is preferably connected to the embodiment of the second panel that is provided with at least one dismantling groove at the inner or outer face of the second panel. The dismantling groove is preferably adapted for insertion of a dismantling tool. The dismantling tool may be inserted into the dismantling groove to un-lock the mechanical locking device. The tongue groove at the edge section of the second edge of the second panel may be open at a back edge of the second panel. A dismantling tool may be inserted into the tongue groove provided that the edge section groove and the tongue groove are open at the back of the first and the second panel.

The flexible tongue may be displaceable in the insertion groove.

The edge section of the second panel may be provided with a calibrating groove.

The first panel or the second panel may be provided with a dismantling groove or recess, wherein dismantling groove or recess is preferably adapted for insertion of a dismantling tool.

- 5 The edge section of the second panel may comprise a first wall and an opposite second wall, wherein the tongue groove may be provided in the first wall, and the minimum second thickness may be measured between a bottom of the tongue groove and the second wall.

10 The flexible tongue may have a first displacement surface and an opposite second displacement surface which are configured to be displaced along a third displacement surface and a fourth displacement surface, respectively, of the insertion groove.

The core material of the first panel and the second panel may comprise a wood fibre based board, such as a HDF, MDF, plywood, solid wood or particleboard, a reinforced plastic board or a wood fibre composite board.

- 15 The first panel and the second panel are preferably provided with a decorative layer.

The outermost surface of the first edge of the first panel may be essentially in the same plane as, for example, flush with, an outer face of the second panel.

- 20 A second aspect of the present disclosure is an assembled product, such as a furniture, comprising the set of panels described above. The assembled product is preferably configured to be assembled without tools.

Brief description of the drawings

Embodiments of the present invention will by way of example be described in more detail with reference to the appended schematic drawings, in which:

- 25 FIGS. 1A-1B show panels provided with a mechanical locking system according to an embodiment of the invention.

FIGS. 2A-2F show a flexible tongue according to an embodiment of the present invention.

- 30 FIGS. 3A-3B show a flexible tongue according to an embodiment of the present invention.

FIGS. 3C-3D show a mechanical locking system for a backside or bottom panel according to an embodiment of the present invention.

FIGS. 4A-4B show embodiments of an assembled product

FIG. 5 shows panels provided with a mechanical locking system according to an
5 embodiment of the present invention.

FIGS. 6A-6B show panels provided with a mechanical locking system according to an embodiment of the present invention.

FIGS. 7A-7B show panels and a disassembling tool and groove according to an embodiment of the present invention.

10

Detailed description

FIGS. 1A-B show two panels 2, 4 that are arranged perpendicular to each other and locked together. The two panels may be a part of a furniture or a furniture component, such as a bookshelf, a cupboard, a wardrobe, a box, a drawer or a furniture component.

15 The two panels may be a first panel 2 having a first main plane and a second panel 4 having a second main plane. The first panel 2 and the second panel 4 are provided with a mechanical locking device for locking a first edge of the first panel 2 to a second edge of the second panel 4, wherein the first main plane is essentially perpendicular to the second main plane. The first panel 2 comprises a core comprising fibres arranged
20 essentially parallel to the first main plane, and the second panel 4 comprises a core comprising fibres arranged essentially parallel to the second main plane. The mechanical locking device comprises an edge section groove 21 at the first edge, and an edge section 22 at the second edge of the second panel 4. The edge section 22 is inserted into the edge section groove 21 for locking the first panel 2 and the second panel 4 in a direction
25 parallel to the first main plane. The mechanical locking device further comprises a flexible tongue 30 arranged in an insertion groove 20 preferably provided in the edge section groove 21 as shown in FIG. 1A. The flexible tongue 30 cooperates with a tongue groove 10, preferably provided at the edge section 22 as shown in FIG. 1A, for locking the first panel 2 and the second panel 4 in a direction parallel to the second main plane.
30 The edge section groove 21 and the tongue groove 10 are preferably formed by mechanically cutting, such as milling, of the first panel 2 and the second panel 4, respectively. The first panel comprises an inner face 60 and an outer face 61 that are

preferably essentially parallel to the first main plane. The second panel 4 comprises inner face 62 and an outer face 63 that are preferably essentially parallel to the second main plane. The inner face 60 of the first panel 2 and the inner face 62 of the second panel are preferably configured to face toward an inside of an assembled product. The edge section 22 of the second panel 4 may be provided with a calibrating groove 40, which reduces the thickness of the edge section 22, at the inner face 62 and/or the outer face 63 of the second panel 4. The calibrating groove 40 is preferably formed by mechanically cutting, such as milling, of the second panel 4.

FIG. 1B shows that the flexible tongue 30 may alternatively be arranged in an insertion groove 20 in the edge section 22 of the second panel 4 and the tongue groove 10 may be arranged in edge section groove 21 of the first edge of the first panel 2. However, a greater size of the insertion groove 20, as compared to the tongue groove 10, may be required. Therefore, the embodiment in FIG. 1A with the insertion groove 20 in the edge section groove 21 may be the preferred embodiment.

An embodiment of the flexible tongue 30, which is displaceable in an insertion groove 20, is shown in FIGS. 2A-2D. FIGS 2A-2B show the flexible tongue 30 in a locked position and FIGS. 2C-2D show the flexible tongue 30 during assembling of the first panel 2 and the second panel 4. FIG. 2B shows a cross section of the flexible tongue 30 in FIG. 2A. FIG. 2D shows a cross section of the flexible tongue 30 in FIG. 2C. The flexible tongue 30 comprises bendable protruding parts 24. A space 23 is provided between the flexible tongue 30 and a bottom wall of the insertion groove 20. FIG. 2C shows that the flexible tongue 30 is pushed into the insertion groove 20 and towards the bottom wall of the insertion groove 20 during assembly of the first panel 2 with the second panel 4. The flexible tongue 30 springs back toward its initial position when the first panel 2 and the second panel 4 have reached a locked position. A recess 25 is preferably arranged at each bendable protruding part.

The flexible tongue 30 may have a first displacement surface 26 and an opposite second displacement surface 27, configured to be displaced along a third displacement surface 28 and a fourth displacement surface 29, respectively, of the insertion groove 20.

An alternative embodiment of the flexible tongue 30, without the protruding bendable parts 24, is shown in FIGS. 2E-2F. FIG. 2F shows a cross section of the flexible tongue

30 shown in FIG. 2E. The alternative embodiment is bendable in its length direction in order to accomplish the same function as the embodiment shown in FIGS. 2A-2D.

A further embodiment of the flexible tongue 30 is shown in FIGS. 3A-3B. FIG. 3A shows the flexible tongue 30 before the first panel 2 and the second panel 4 are locked in the direction parallel to the second main plane. The flexible tongue 30 comprises an inner part 31 provided with wedge elements and outer part for the locking of the first panel 2 and the second panel 4 in the direction parallel to the second main plane. The locking is obtained by applying a force P, in a direction parallel to the first edge of the first panel 2, at a short edge of the outer part. The force P displaces the outer part of the flexible tongue 30 in the direction parallel to the first edge of the first panel 2 and the wedge elements force the outer part of the flexible tongue 30 in a perpendicular direction, out of the insertion groove 20. The resulting displacement, shown with arrow 32, of the outer part of the flexible tongue 30 is therefore in a direction between the direction parallel to the first edge of the first panel 2 and the perpendicular direction. Each of the panels 2 – 6 may include a flexible tongue 30.

FIG. 4A shows an assembled product, such as furniture, with a frame that comprises a first set of the first panel 2 and the second panel 4 locked to a second set of the first panel 6 and the second panel 5. A first edge of the second panel 4, 5 may be essentially identical to the second edge of the second panel 4, 5 and a second edge of the first panel 2, 6 may be essential identical to the first edge of the first panel 2, 6 to enable locking the first set and the second set together as shown in FIG. 4A. The first panel 2 of the first set is arranged opposite to the first panel 6 of the second set. The second panel 4 of the first set is arranged opposite the second panel 5 of the second set. A third panel 3 configured essentially as the second panel and provided with the flexible tongue 30 at an edge section of the third panel, may be locked to the first panel 2 of the first set and the first panel 6 of the second set.

FIG. 4B shows an alternative embodiment of the frame with an alternative configuration of the first edge of the second panel 6 of the second set and the second edge of the first panel 2 of the first set. FIG. 4B shows that assembly involves, using the first panel 6 of the second set as an example, simply displacing the first panel in the direction of arrow 44 such that no further steps or tools may be necessary to lock the first panel 6 of the second set with other panels of the product. See also, Swedish patent application SE 1351060-7, which is expressly incorporated herein by reference in its entirety.

All edges of the panels 2 - 6 of the assembled product may be locked together with a mechanical device comprising the flexible tongue 30. The assembling may be completed without the use of tools and/or binding agents such as glue.

5 A fourth panel 8, such as a back panel or a bottom panel, may be arranged in a third main plane, which is essentially perpendicular to the first main plane and the second main plane. A first edge and a second edge of the fourth panel 8 may be locked by a mechanical locking device at a first back or bottom edge and a second back or bottom edge, respectively, of the frame. A third edge and a fourth edge of the fourth panel 8 are preferably inserted into a groove provided at a third back or bottom edge and a fourth
10 back or bottom edge, respectively, of the frame. The frame may be subject to a force F during transportation, production or assembling of the assembled product. Locking of the fourth panel 8 to the frame by the mechanical locking device improves the strength and the stability of the assembled product. The fourth panel may comprise two or more elements 8a, 8b which are preferably locked together by a mechanical locking system.
15 An embodiment of the mechanical locking system is shown in FIG. 3C, discussed below.

The first panel 6 of the second set may be locked to the other panels of the frame at a later occasion and/or at another location. The first panel 6 of the second set may be locked to the other panels of the frame and the bottom or back panel by simple displacement 44 as discussed above, and no further steps or tools may be necessary.

20 FIG. 3C shows an embodiment of a furniture panel 8, such as a back or bottom panel, comprising a first element 8a and a second element 8b provided with a mechanical locking system configured to lock the first 8a element and the second element 8b together.

25 The first main plane of the first element 8a is essentially parallel to a second main plane of the second element 8b, wherein the furniture panel comprises a first face 85 and an opposite second face 86 which are parallel to a main plane of the furniture panel 8. The mechanical locking system may include:

30 a first tongue 64 provided at a first edge of the first element 8a, wherein the first tongue 64 is configured to cooperate with a first tongue groove 50 provided at a second edge of the second element 8b for locking together the first element 8a and the second element 8b in a first vertical direction V1;

a second tongue 72 at the second edge of the second element 8b, wherein the second tongue 72 is configured to cooperate with a second tongue groove 73 at the first edge of the first element 8a for locking together the first element 8a and the second element 8b in a second vertical direction V2;

5 a first pair of locking surfaces 83 provided above the second tongue 72 and the second tongue groove 73 for locking together the first element 8a and the second element 8b in a first horizontal direction H1; and

10 second pair of locking surfaces 84 provided below the first tongue 64 and the first tongue groove 50 for locking together the first element 8a and the second element 8b in a second horizontal direction H2.

The first pair of locking surfaces 83 is preferably essentially vertical. The second pair of locking surfaces 84 is also preferably essentially vertical.

The first tongue 64 and the first tongue groove 50 cooperate at a third pair of locking surfaces 87 that is preferably arranged essentially horizontally.

15 The second tongue 72 and the second tongue groove 73 cooperate at a fourth pair of locking surfaces 74 that is preferably arranged at an angle 88 to the main plane of the furniture panel 8 that is greater than zero. The angle 88 has a range that allows the first element 8a to be locked to the second element 8b by an angling motion of the first element 8a relative to the second element 8b or of the second element 8b relative to the first element 8a, wherein the first tongue 64 is inserted in the first tongue groove 50.

20 The first face 85 of the first element 8a and the second element 8b is arranged upwards in the vertical direction, e.g., in the direction where the greatest load F1 is likely to be exerted on the furniture panel 8, to prevent the first element 8a and the second element 8b from being unlocked by a reversed angling motion. A second face 86 is arranged downwards in the vertical direction, e.g., in the direction where the smallest load F2 is likely to be applied on the furniture panel 8.

30 The second element 8b may include a strip 70 extending from first tongue groove 50 and including a protruding element 71 and the. The strip 70 may include a recess adjacent the protruding element 71. The protruding element 71 essentially matches a third groove 80 provided at the first edge of the first element 8a. The protruding element 71 may protrude upwards in the vertical direction V and the groove 80 may be open downwards in the vertical direction V. A third space 75, that extends in the horizontal direction H,

may be provided between the protruding element 73 and the third groove 80. The third space 75 may facilitate the locking by an angling motion. FIG. 5 shows an embodiment that comprises a first thickness 55 of a core material of the first panel 2, between the edge section groove 21 and the outermost surface of the first edge in a direction parallel to the first main plane. The first thickness 55 is greater than a minimum second thickness 54 of a core material of the edge section 22 of the second panel 4. The first thickness 55 ranges from between 1,1 and 3,0 times larger than the minimum second thickness 54, and may be at least about 1,25 times larger; preferably about 1,5 times larger; and more preferably about 2,0 times larger than the minimum second thickness. In an embodiment, the edge section groove 21 comprises a first wall 56 and an opposed second wall 57, wherein the first wall 56 is closer to the outermost surface 53 of the first edge than the second wall 57. The first thickness 55 is preferably measured between the first wall 56 and the outermost surface 53 of the first edge. The first wall 56 and the second wall 57 are preferably connected by a bottom wall 58.

The edge section 22 of the second panel 4 may comprise a first wall 96 and an opposite second wall 98, wherein the tongue groove 10 is provided in the first wall 96. The minimum second thickness 54 may be measured between a bottom of the tongue groove 10 and the second wall 98.

In the embodiment, having the insertion groove 20 extend along essentially the entire length of the edge section groove 21 of first edge of the first panel may lead to an easier production of the first panel 2. Having the tongue groove 10 extend along essentially the entire length of the edge section 22 of the second panel 4 may also lead to an easier production of the second panel 4.

The outermost surface 53 of the first panel 2 is in a preferred embodiment essentially in the same plane as, for example, flush with, the outer face 63 of the of the second panel 4.

An edge of the opening of the edge section groove 21 may be provided with a bevel 59 or rounding in order to facilitate the insertion of the flexible tongue 30 into the insertion groove 20.

FIG. 6A shows an embodiment of a mechanical locking device for locking the fourth panel 8 to any first or second back or bottom edge 81 of a frame. An embodiment of the frame is shown in FIGS. 4A-4B. The mechanical locking device may be essentially identical to the mechanical locking device described above.

FIG. 6B shows an embodiment of a mechanical locking device for locking the third panel 3 to any first or second panel 82 of a frame. An embodiment of the frame is shown in FIGS. 4A-4B. The mechanical locking device may be essentially identical to the locking device described above.

5 FIGS. 7A-7B show an embodiment of a dismantling groove or recess 34 that is provided at the inner face 62 of the second panel 4. Said dismantling groove or recess 34 is preferably adapted for insertion of a dismantling tool 90. The mechanical locking system may be unlocked by insertion of the dismantling tool 90 into dismantling groove. The
10 insertion tool 90 is preferably configured to push the flexible tongue 30 further into the insertion groove 20 in order to unlock the mechanical locking system.

FIG. 7B shows that a dismantling tool 90 may be inserted into the tongue groove 10 provided that the edge section groove 21 and the tongue groove 10 are open at the back and/or front of the first panel 2 and the second panel 4.

The insertion of the flexible tongue 30 into the insertion groove 20 may be facilitated if a
15 top surface 92 of the first edge section of the first panel 2 at the first wall 56 of the edge section groove 21 is lowered. A lowered top surface 92 increases the distance between a plane 91 extending in a direction of a lower surface of the insertion groove 20 and the top surface 92. This increased distance may provide more space for a tongue insertion machine.

20 The core material of the panels and elements in the embodiments above preferably comprises a wood fibre based board, such as a HDF, MDF, plywood, solid wood or particleboard, a reinforced plastic board, or a wood fibre composite board.

When the word "about" is used in this specification in connection with a numerical
25 value, it is intended that the associated numerical value include a tolerance of +/- 10% around the stated numerical value.

CLAIMS

1. A set of panels comprising a first panel (2) having a first main plane and a second panel (4) having a second main plane, wherein the first panel and the second panel are provided with a mechanical locking device for locking a first edge of the first panel (2) to a second edge of the second panel (4), wherein the first main plane is essentially perpendicular to the second main plane, wherein the first panel comprises a core comprising fibres arranged essentially parallel to the first main plane and the second panel comprises a core comprising fibres arranged essentially parallel to the second main plane, and the mechanical locking device comprises:
- an edge section groove (21) at the first edge of the first panel, wherein an edge section (22) of the second edge of the second panel is insertable into the edge section groove (21) for locking the first panel and the second panel (2, 4) together in a direction parallel to the first main plane; and
- a flexible tongue (30) arranged in an insertion groove (20) provided in the edge section groove (22), wherein said flexible tongue cooperates with a tongue groove (10) provided at the edge section of the second panel (22), for locking the first panel and the second panel (2, 4) in a direction parallel to the second main plane,
- characterized in that** a first thickness (55) of a core material of the first panel between the edge section groove (21) and the outermost surface of the first edge in a direction parallel to the first main plane is greater than a minimum second thickness (54) of a core material of the edge section of the second panel (22).
2. The set of panels as claimed in claim 1, wherein the first thickness (55) is between 1,1 and 3,0 times larger than the minimum second thickness (54) .
3. The set of panels as claimed in claim 1 or 2, wherein the first thickness (55) is about 1.25 times larger than the minimum second thickness (54).
4. The set of panels as claimed in any one of the preceding claims, wherein the edge section groove (21) comprises a first wall (56) and an opposed second wall (57), wherein the first wall is closer to the outermost surface of the first edge than the second wall, the first thickness (55) is measured between the first wall (56) and the outermost surface of the first edge.

5. The set of panels as claimed in any one of the preceding claims, wherein the insertion groove (20) extends along essentially the entire length of the edge section groove of first edge.

5

6. The set of panels as claimed in any one of the preceding claims, wherein the tongue groove (10) extends along essentially the entire length of the edge section of the second panel.

10

7. The set of panels as claimed in any one of the preceding claims, wherein the flexible tongue (30) is displaceable in the insertion groove.

8. The set of panels as claimed in any one of the preceding claims, wherein the edge section of the second panel is provided with a calibrating groove (40).

15

9. The set of panels as claimed in any one of the preceding claims, wherein the first panel or the second panel is provided with a dismantling recess, said dismantling recess being adapted for insertion of a dismantling tool (90).

20

10. The set of panels as claimed in any one of the preceding claims, wherein the edge section of the second panel comprises a first wall and an opposite second wall, wherein the tongue groove (10) is provided in the first wall, and the a minimum second thickness (54) is measured between a bottom of the tongue groove and the second wall.

25

11. The set of panels as claimed in any one of the preceding claims, wherein the flexible tongue has a first displacement surface (26) and a opposite second displacement surface (27), which are configured to be displaced along a third displacement surface and a fourth displacement surface (28, 29), respectively, of the insertion groove (20).

30

12. The set of panels as claimed in any one of the preceding claims, wherein the core material of the first panel and the second panel comprises a wood fibre based board, such as a HDF, MDF, plywood, solid wood or particleboard, or a reinforced plastic board or a wood fibre composite board.

13. The set of panels as claimed in any one of the preceding claims, wherein the outermost surface of the first edge (53) of the first panel (2) is essentially flush with the outer face (63) of the second panel (4).

5

14. An assembled product, such as a furniture, comprising the set of panels as claimed in any one of the preceding claims.

FIG 1A

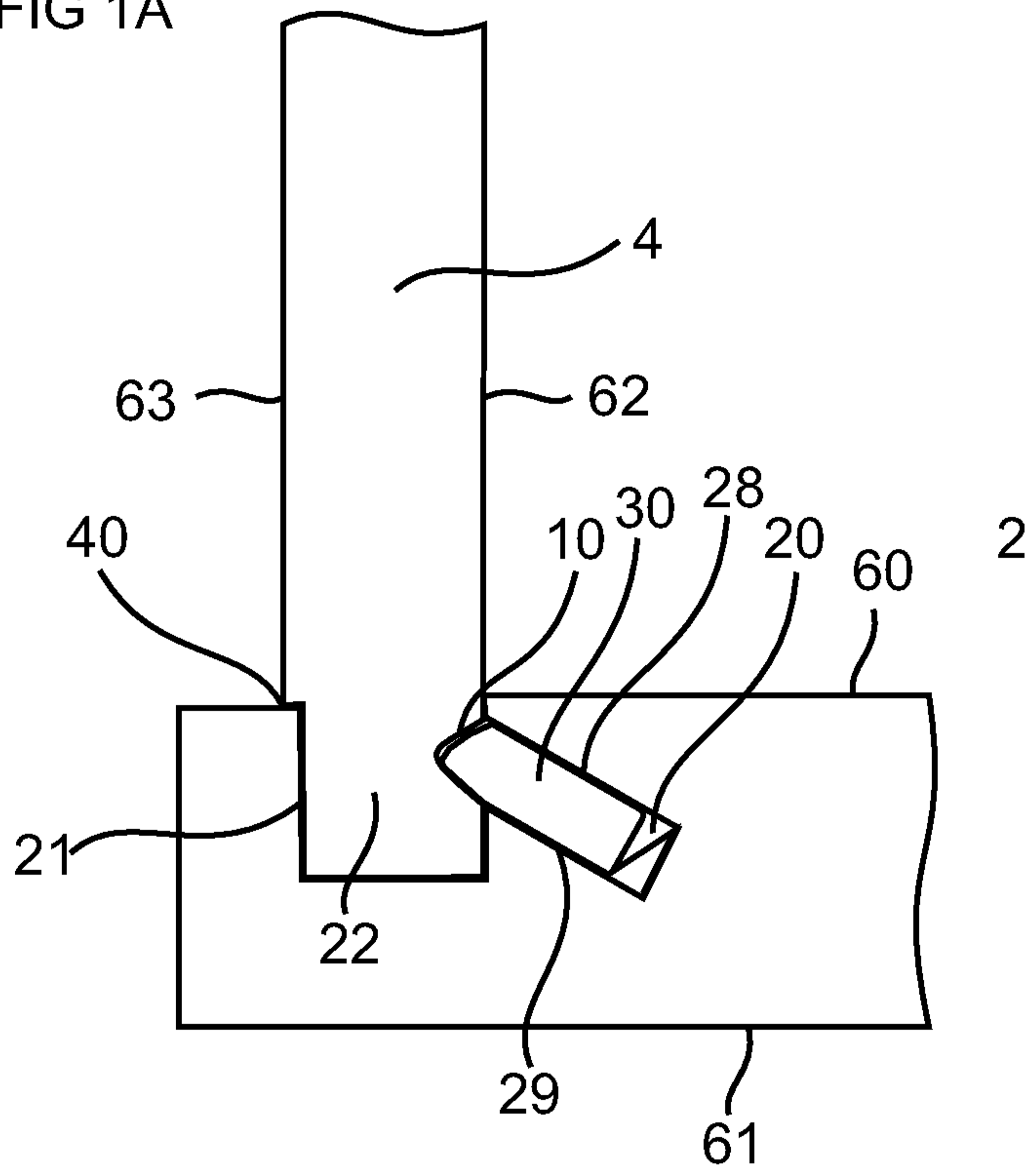

FIG 1B

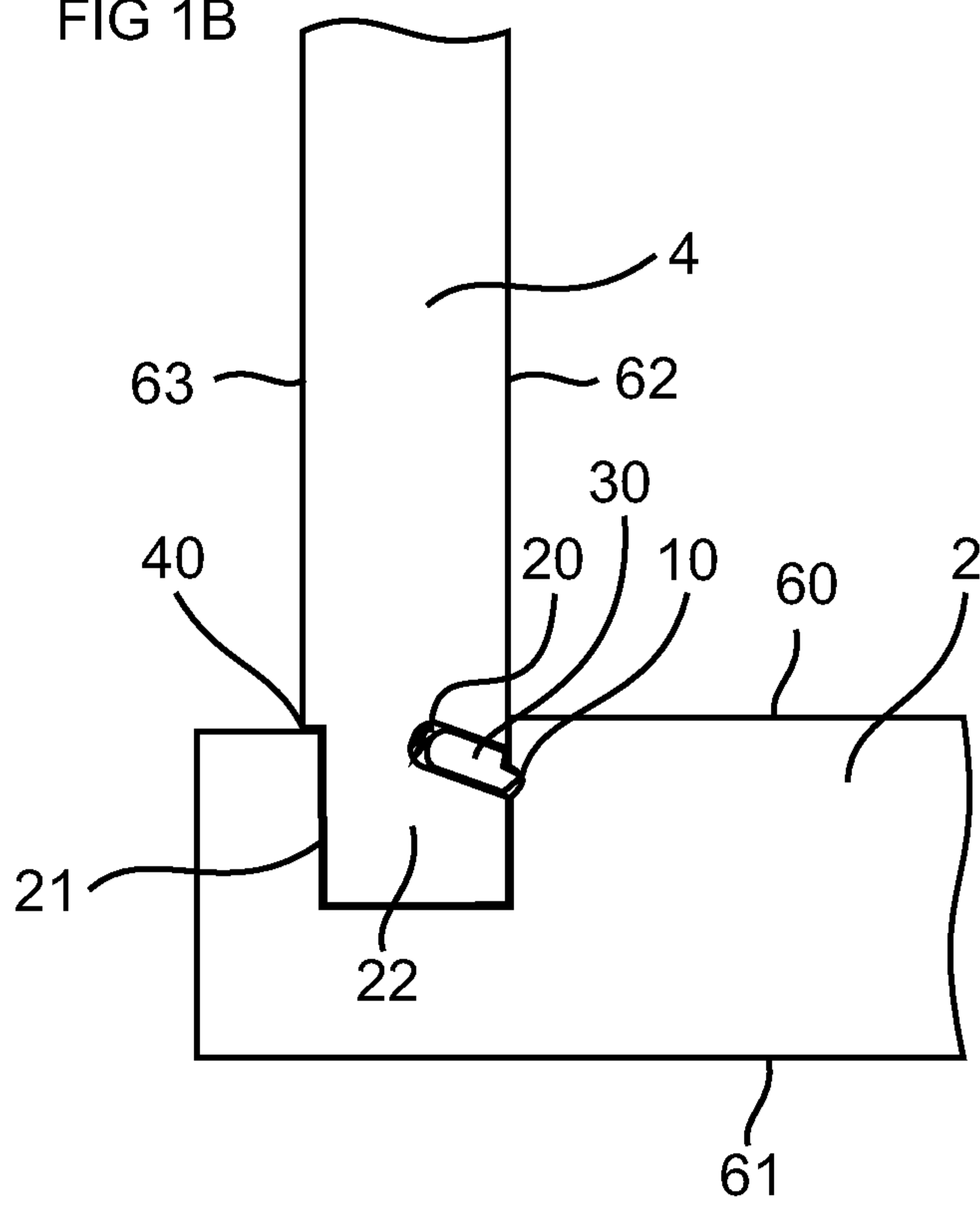

FIG 2A

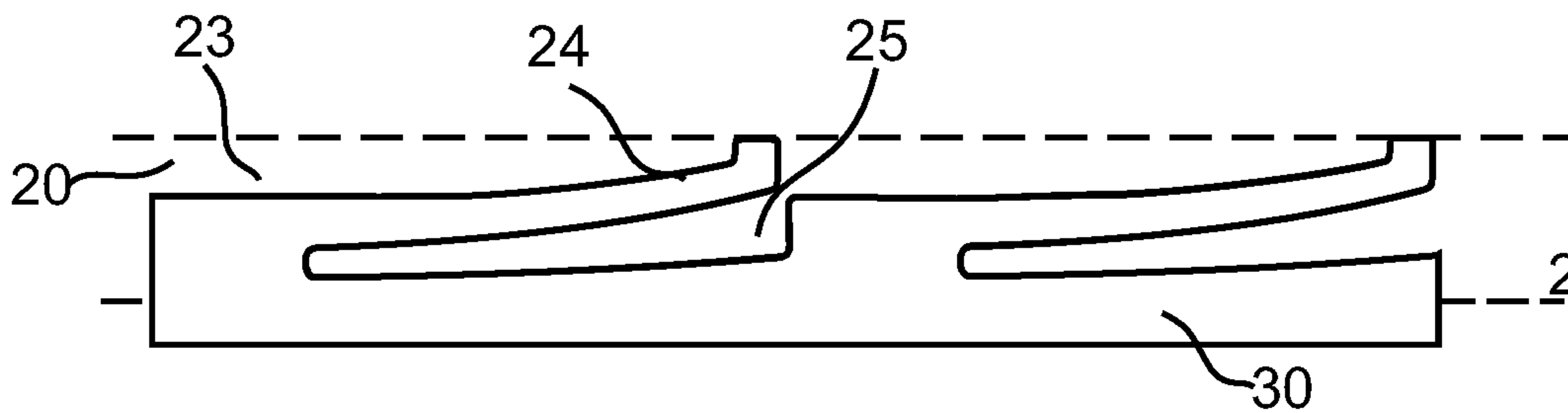

FIG 2B

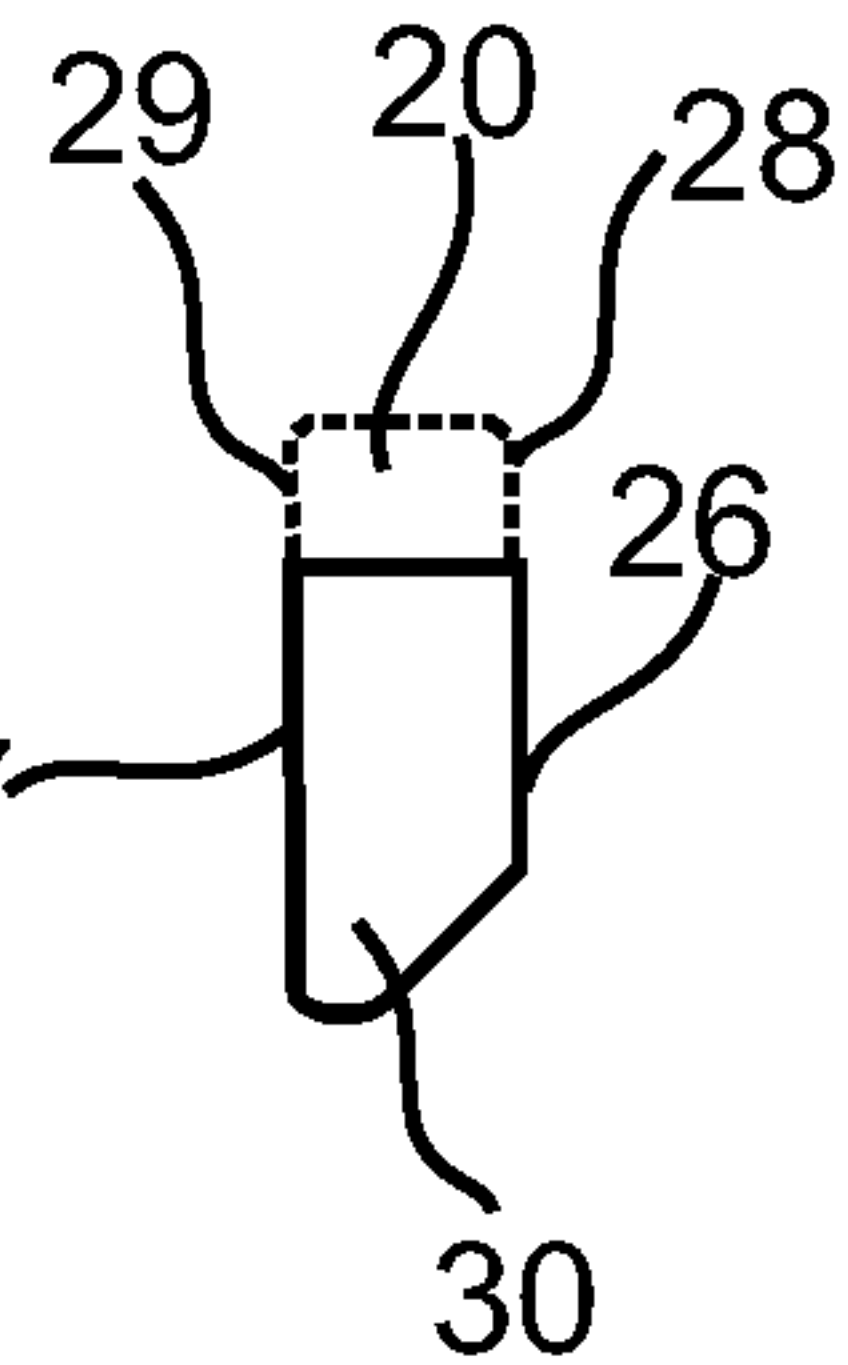

FIG 2C

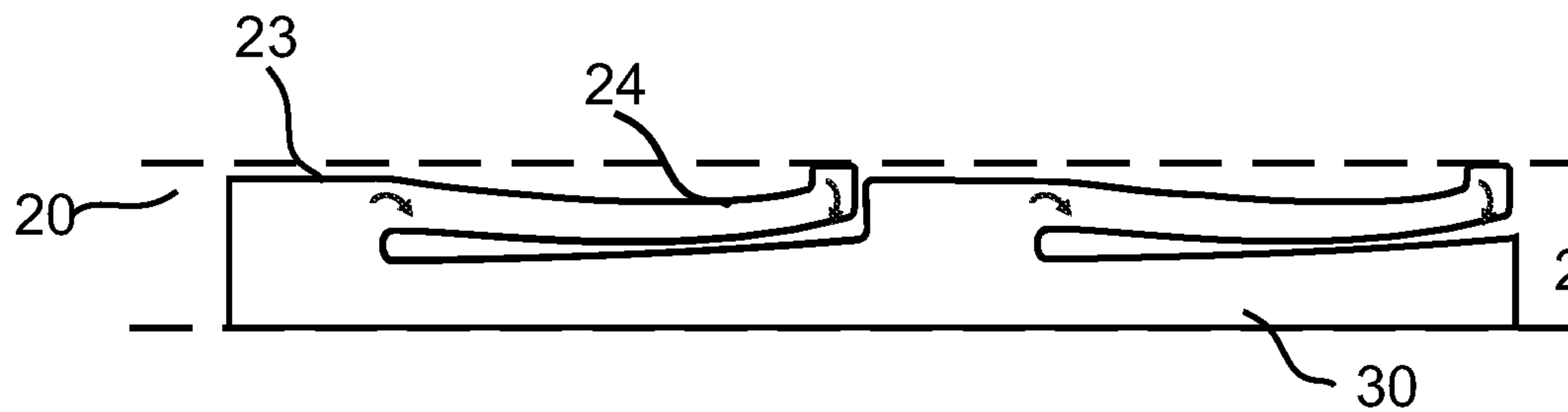

FIG 2D

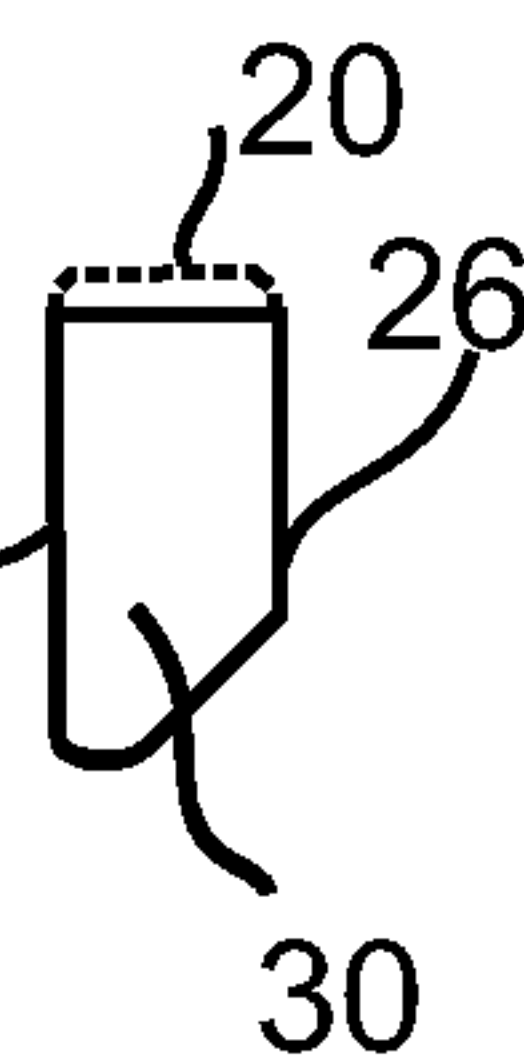

FIG 2E

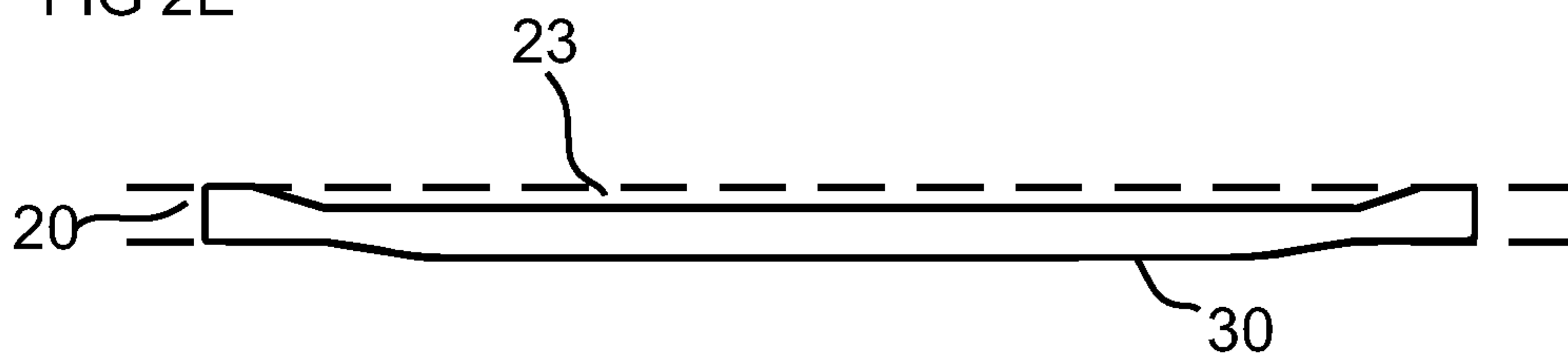

FIG 2F

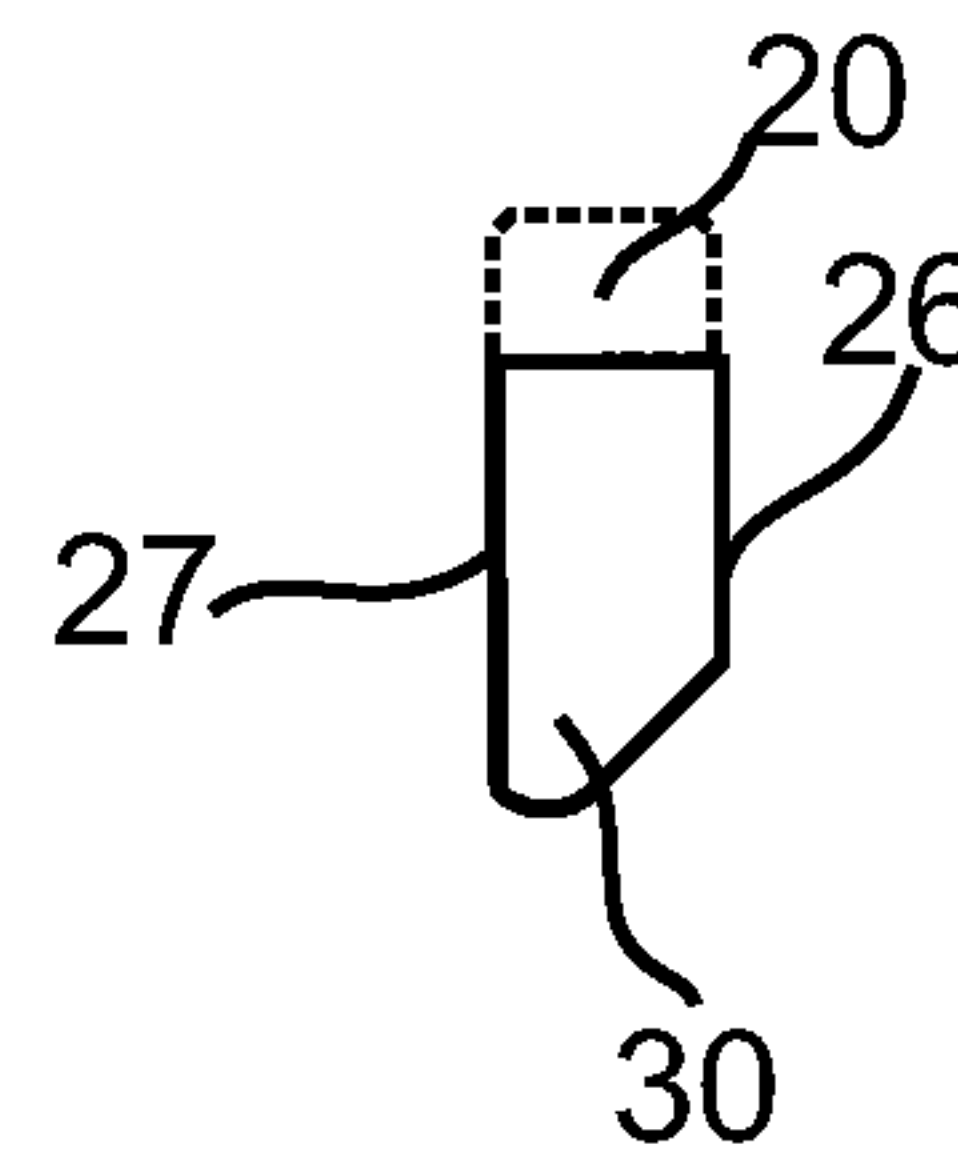

FIG 3A

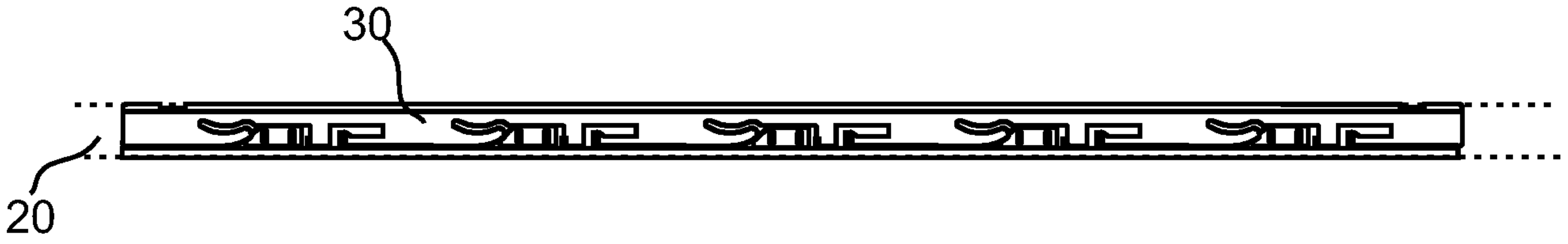

FIG 3B

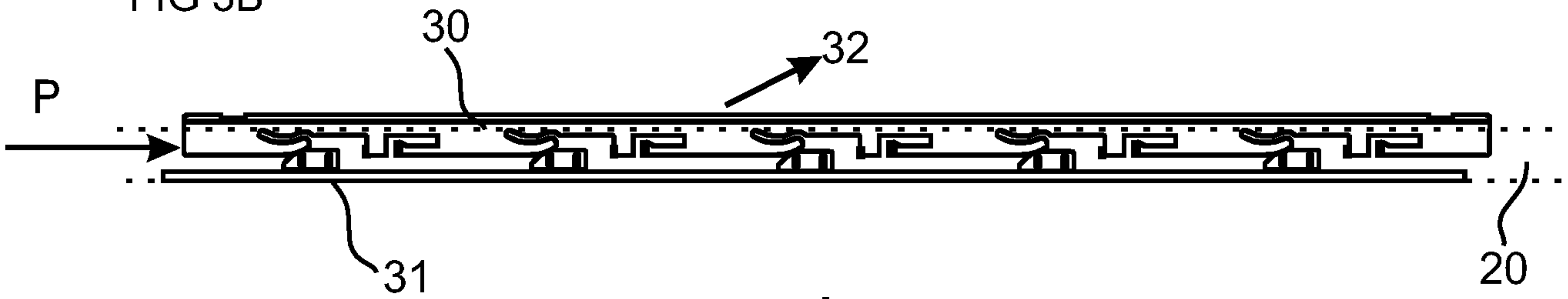

FIG 3C

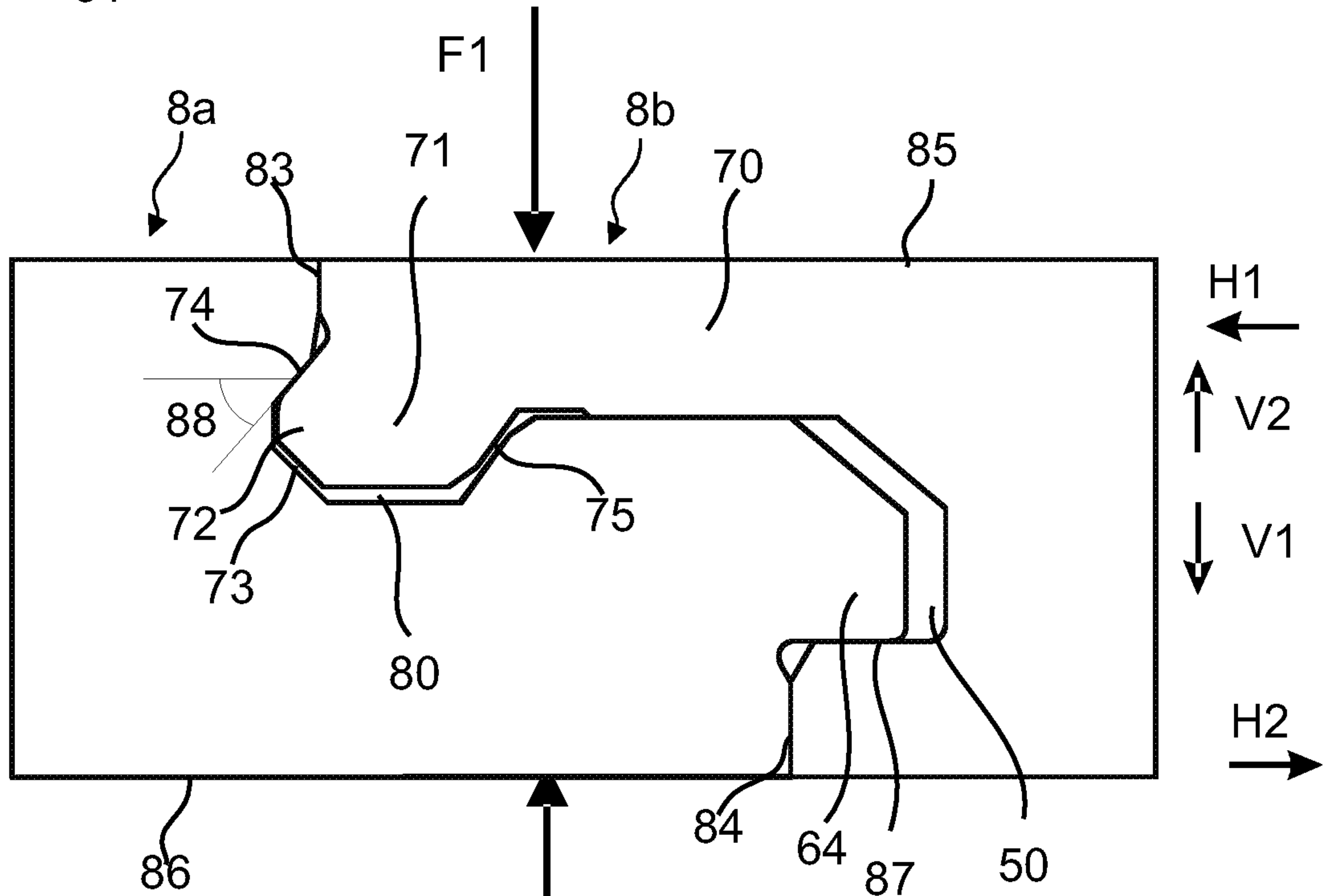
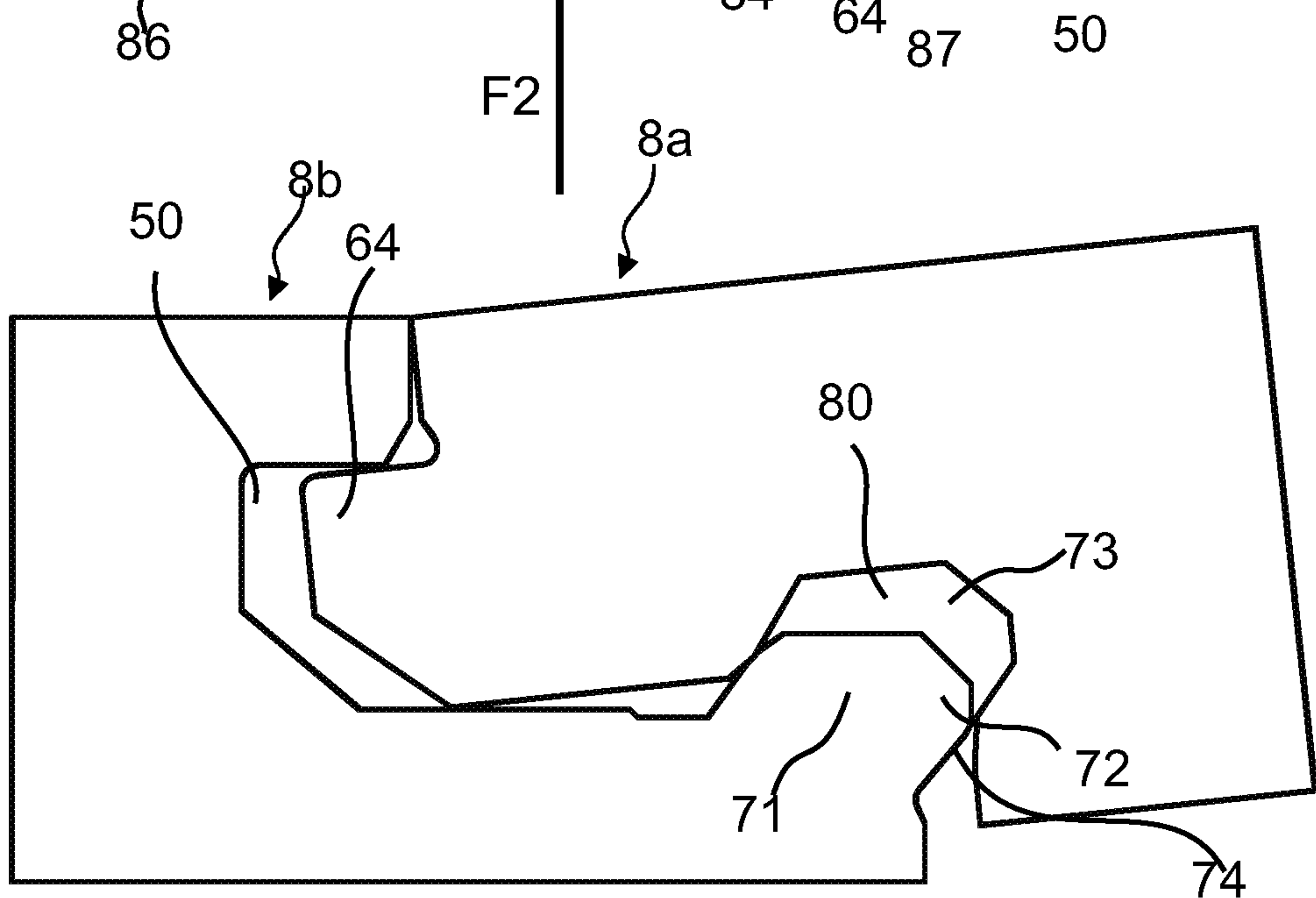

FIG 3D



4/7

FIG 4A

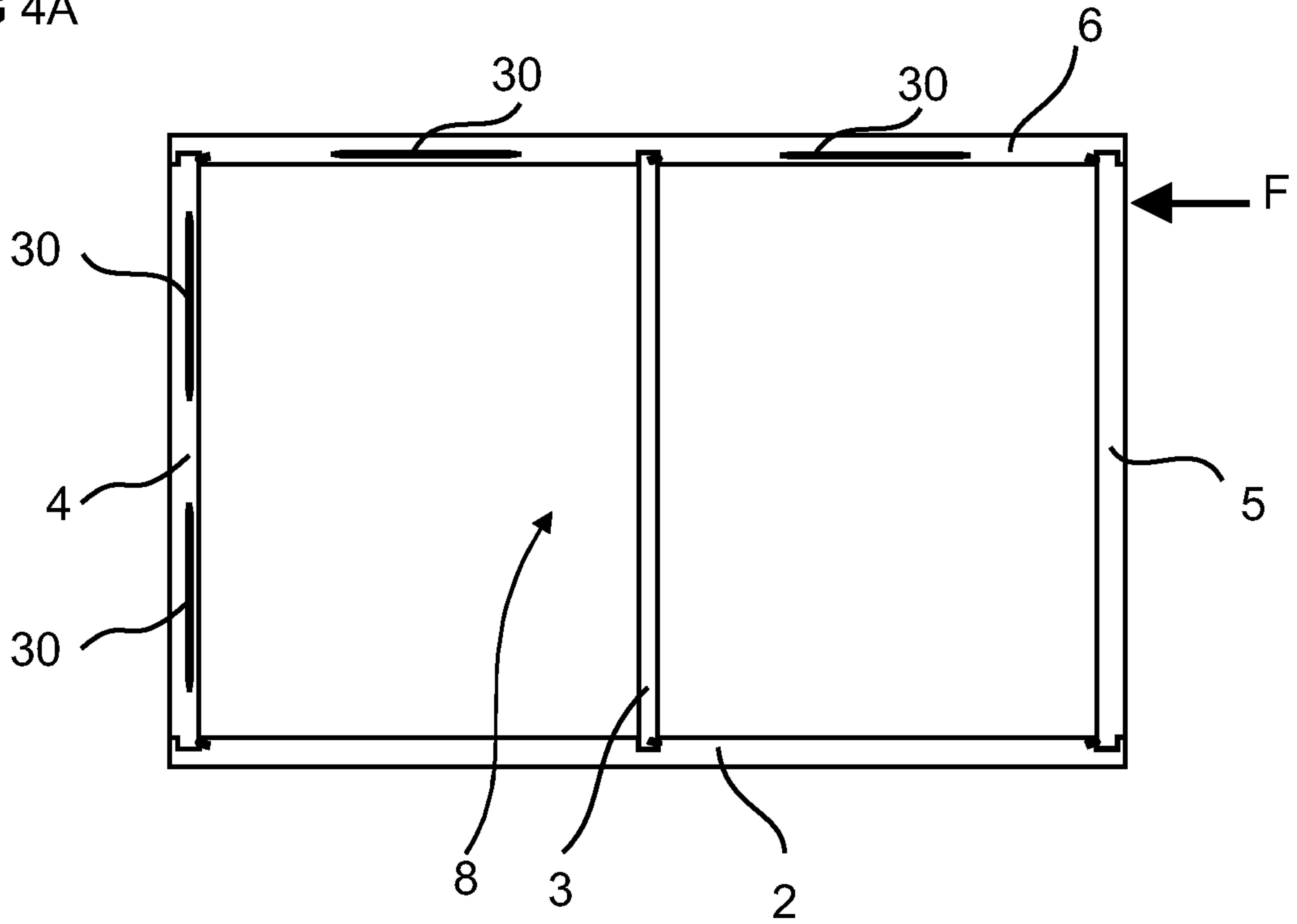
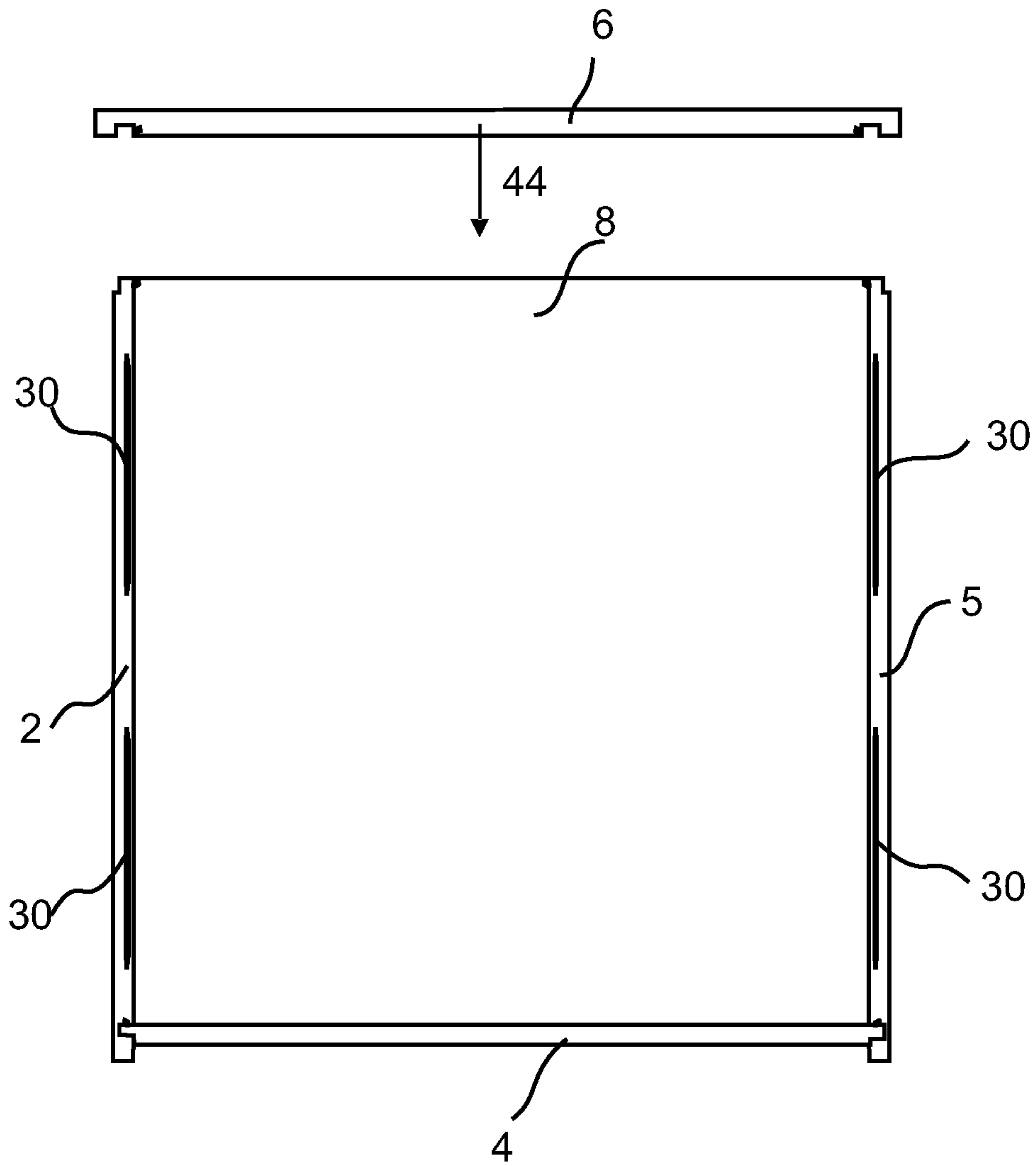
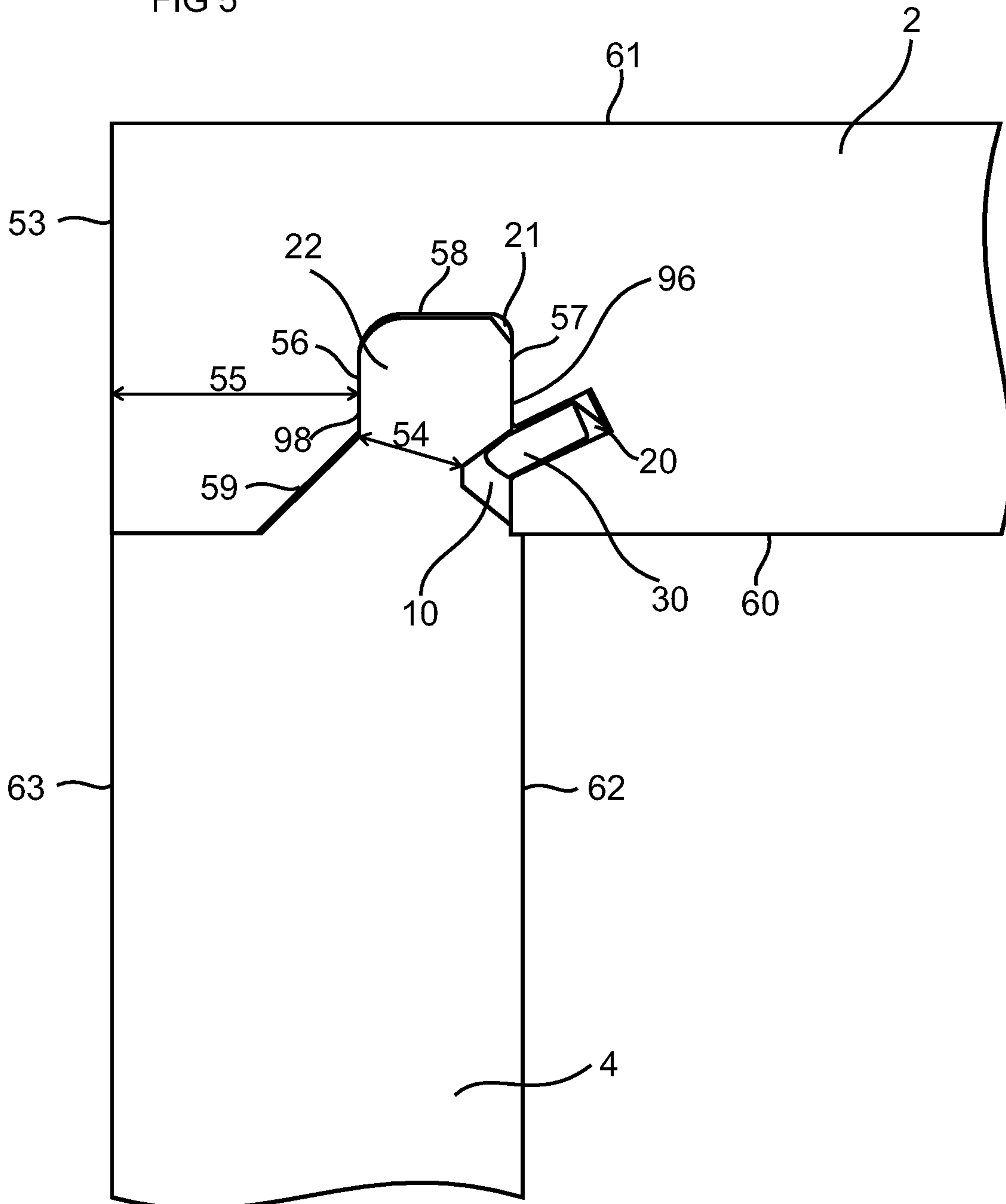

FIG 4B



5/7

FIG 5



6/7

FIG 6A

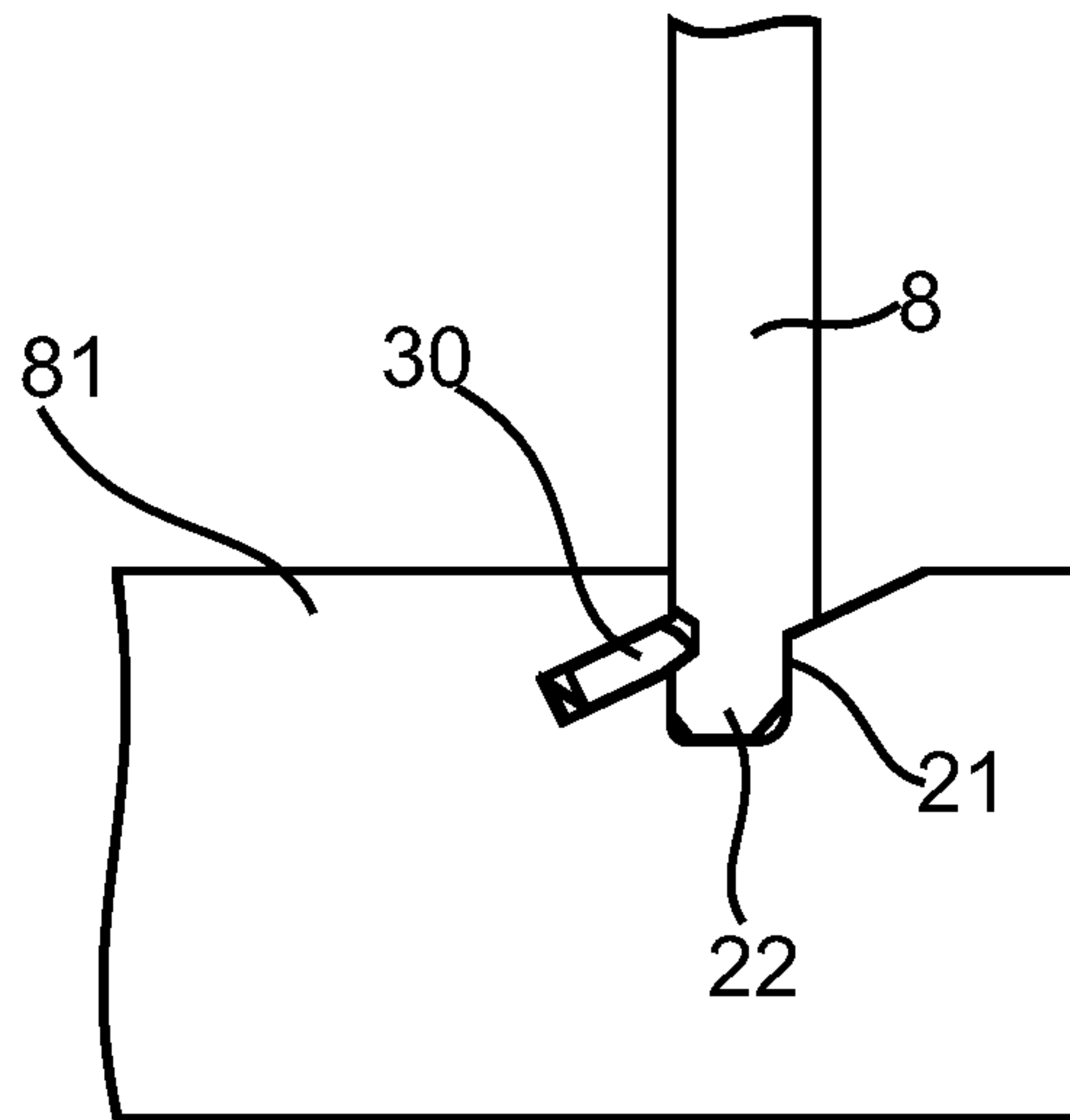

FIG 6B

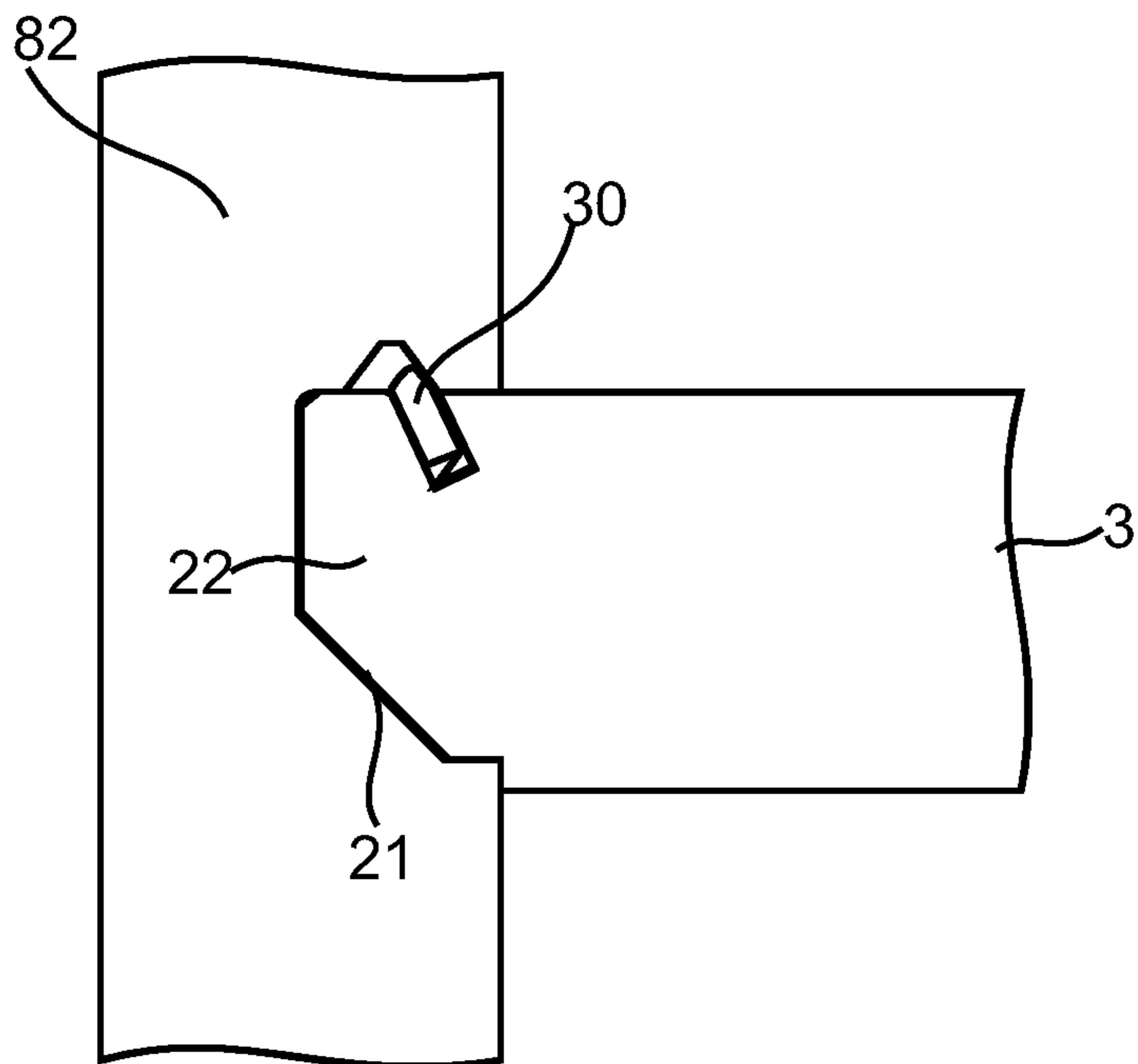

FIG 7A

7/7

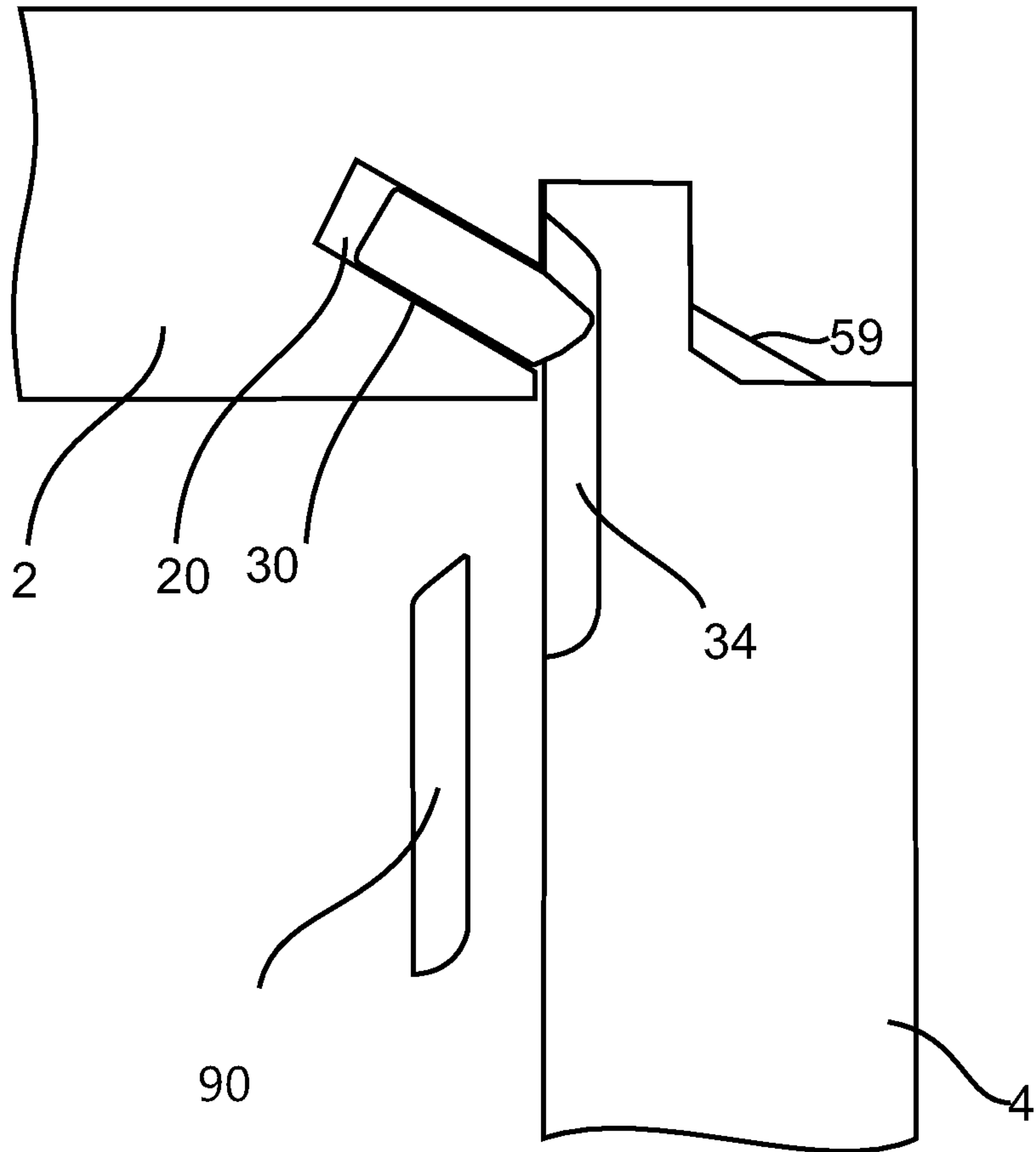

FIG 7B

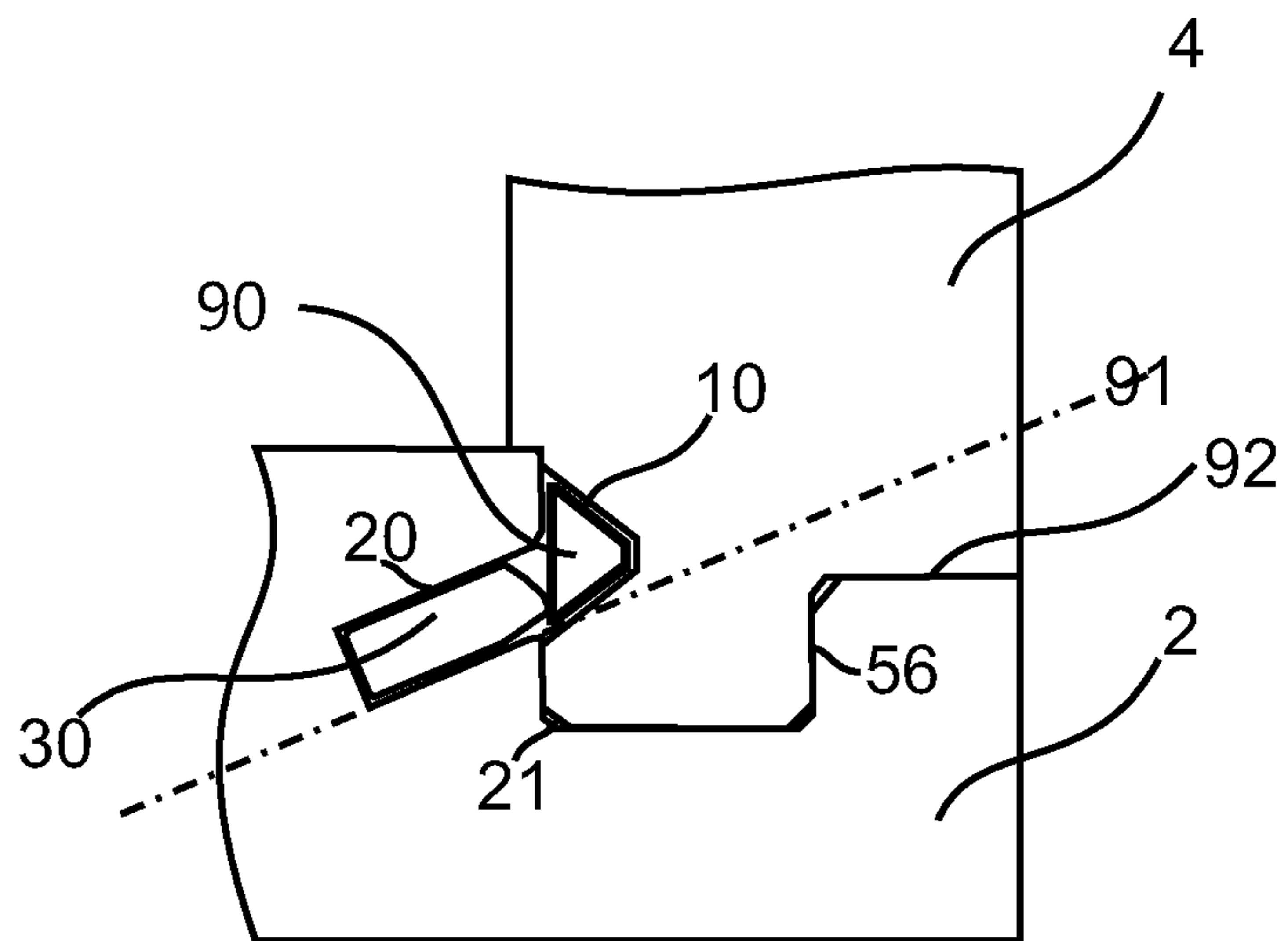

FIG 5

