

[54] CHEST DRAINAGE BOTTLE

[56] References Cited

[75] Inventors: Donald P. Elliott, Denver; William L. Halseth, Parker; William R. King, Lakewood, all of Colo.

U.S. PATENT DOCUMENTS

D. 222,312	10/1971	Kurtz et al.	.....	D24/56
D. 245,372	8/1977	Kurtz et al.	.....	D24/59
D. 255,937	7/1980	Kurtz et al.	.....	D24/59
4,018,224	4/1977	Kurtz et al.	.....	128/276
4,105,031	8/1978	Kurtz et al.	.....	128/276

[73] Assignee: C. R. Bard Inc., Murray Hill, N.J.

Primary Examiner—Bernard Ansher  
Attorney, Agent, or Firm—Edwin L. Spangler, Jr.

[\*\*] Term: 14 Years

[57] CLAIM

[21] Appl. No.: 266,981

The ornamental design for a chest drainage bottle, as shown.

[22] Filed: May 26, 1981

DESCRIPTION

[51] Int. Cl. .... D24—02

FIG. 1 is a perspective view looking down and to the right at the front of the chest drainage bottle showing our new design;

[52] U.S. Cl. .... D24/59; D24/56; 128/276

FIG. 2 is a perspective view looking up and to the right at the rear thereof;

[58] Field of Search .... D24/59, 56, 51; 128/276, 275, 278

FIG. 3 is a front elevational view thereof;

FIG. 4 is a right side elevational view thereof; and,

FIG. 5 is a top plan view thereof.

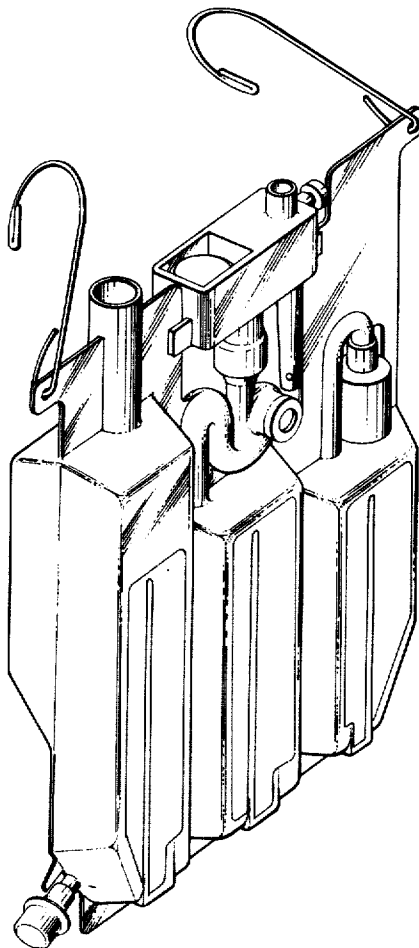

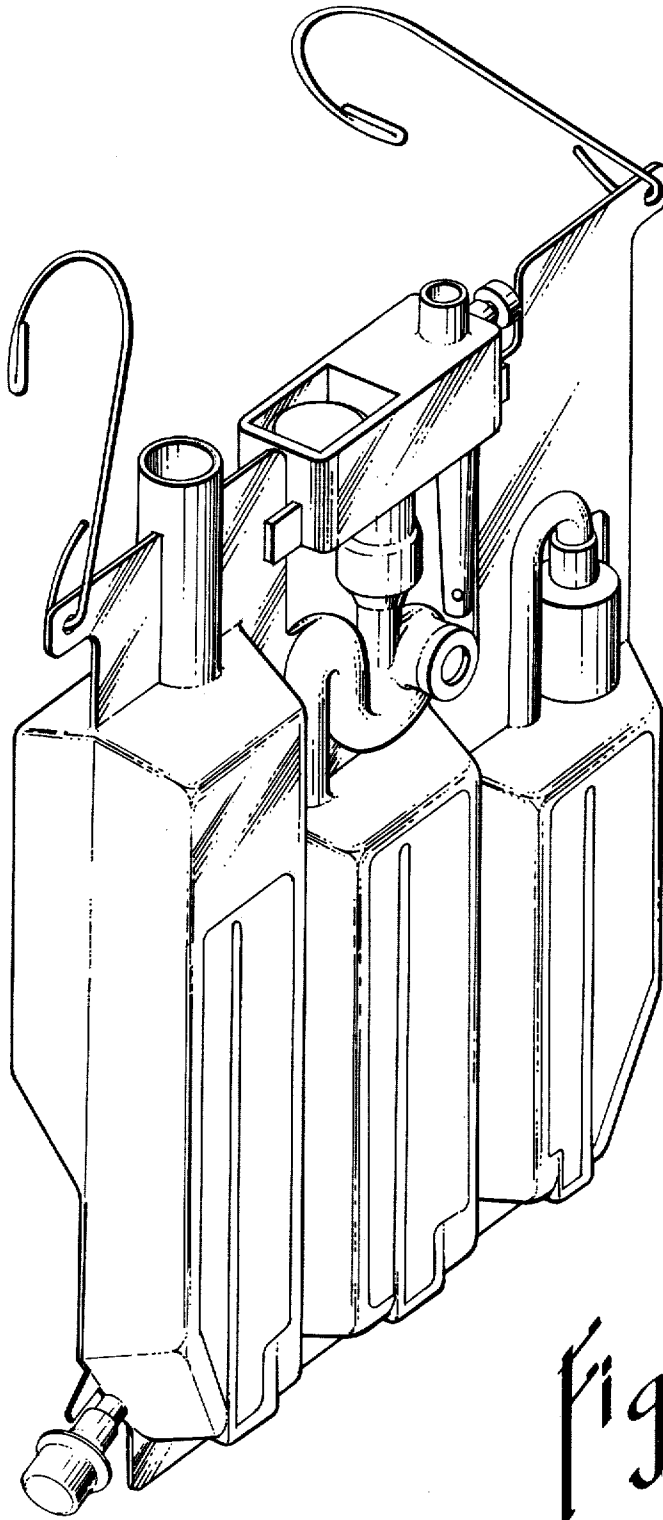
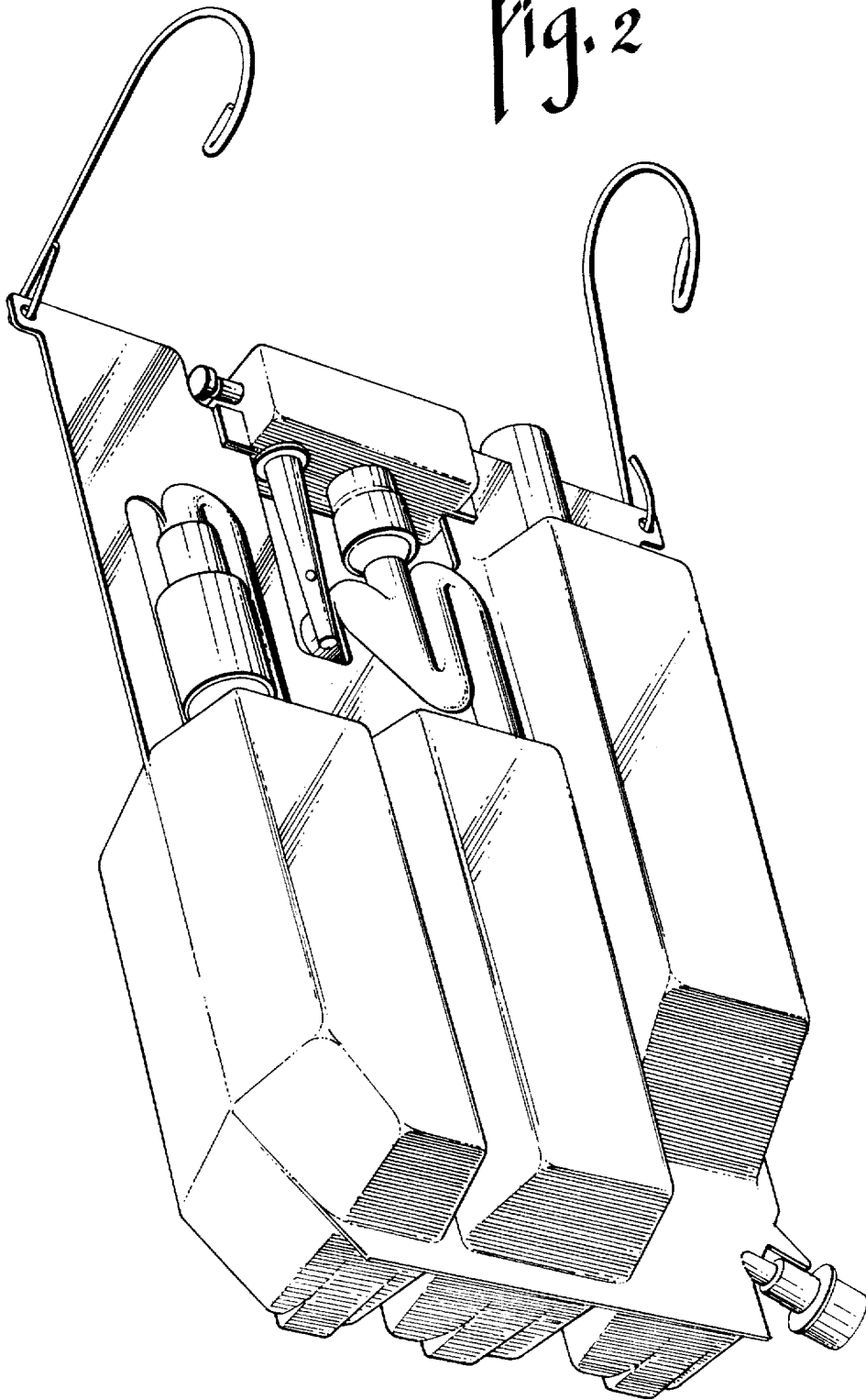
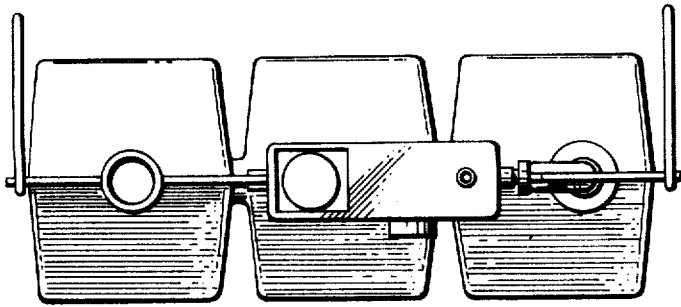

Fig. 1

*Fig. 2*





*Fig. 5*

*Fig. 4*

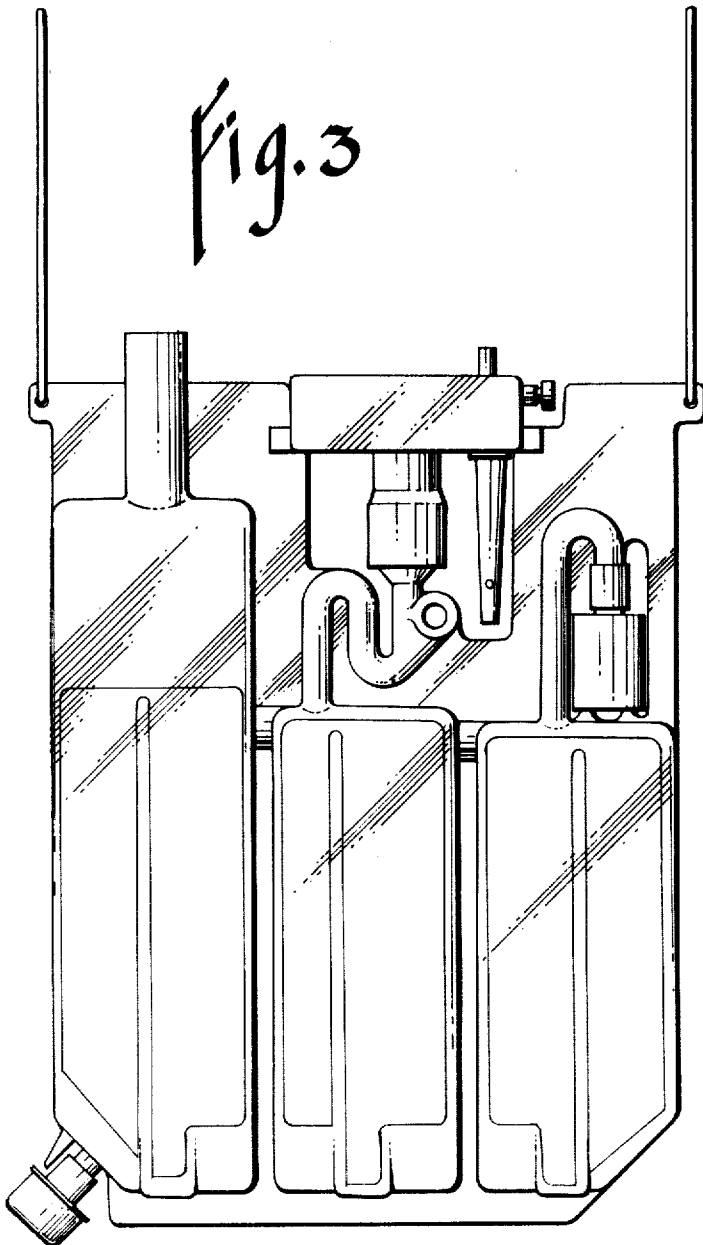

*Fig. 3*

