

W. S. DARLEY.
GAS HEATED SAD IRON.
APPLICATION FILED JULY 15, 1910.

1,000,497.

Patented Aug. 15, 1911.

2 SHEETS—SHEET 1.

Fig. 1.

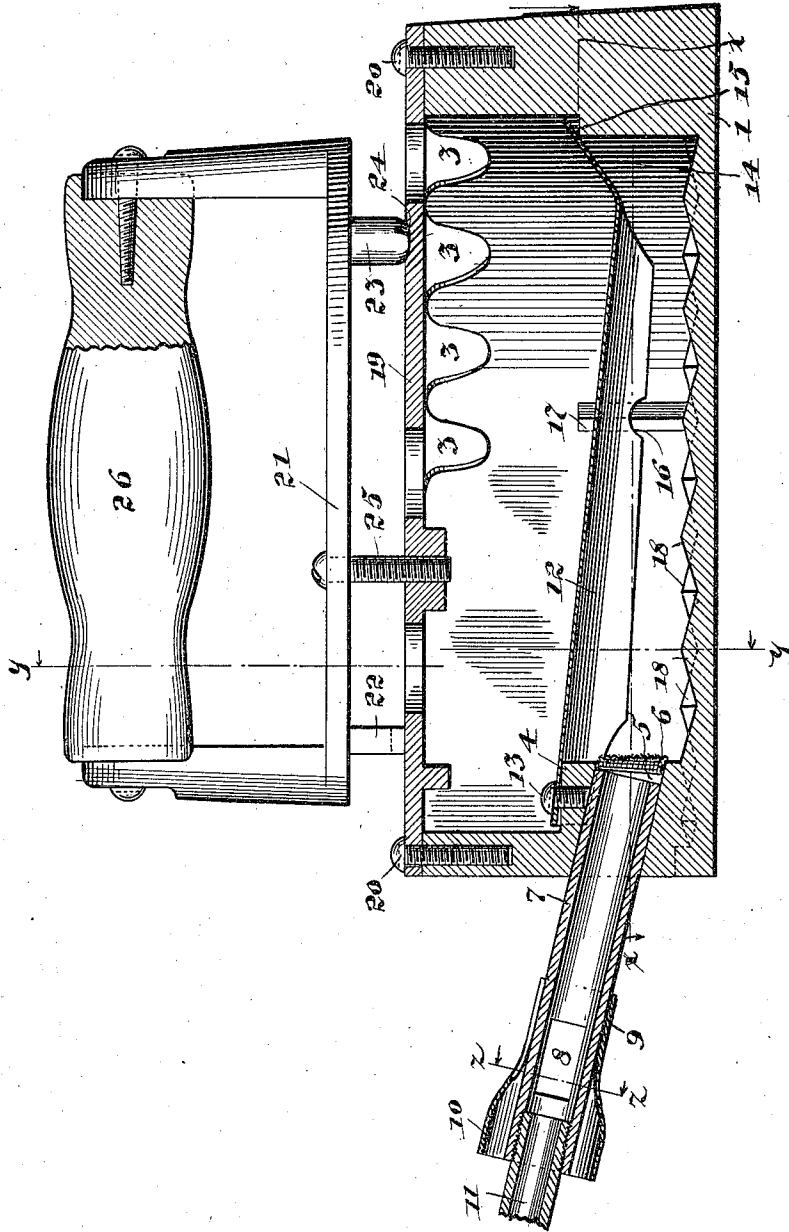

Witnesses:

C. C. Wessels.

B. G. Richards

Inventor:

William S. Darley,

By Joshua R. Horne
his Attorney.

W. S. DARLEY.
 GAS HEATED SAD IRON.
 APPLICATION FILED JULY 15, 1910.

1,000,497.

Patented Aug. 15, 1911.

2 SHEETS—SHEET 2.

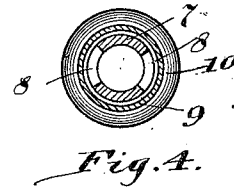
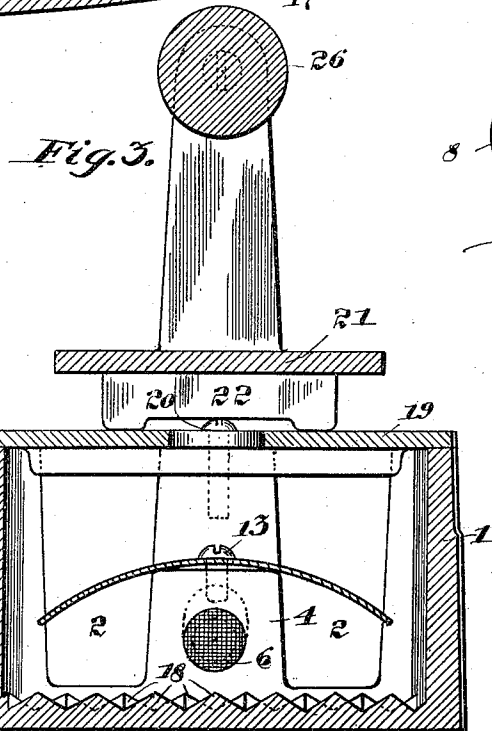
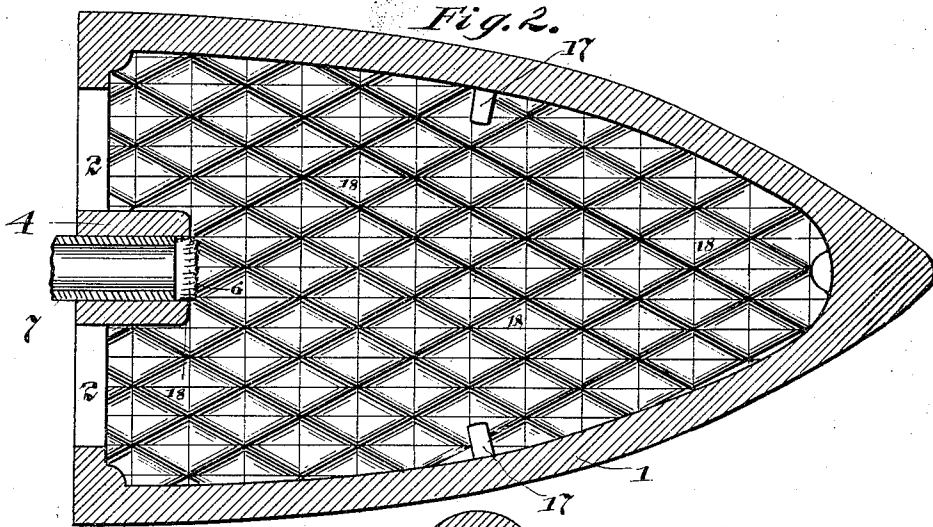

Witnesses:

C. E. Wessels.

B. G. Richards

Inventor:

William S. Darley,

By Joshua R. Stone
 his Attorney.

UNITED STATES PATENT OFFICE.

WILLIAM S. DARLEY, OF CHICAGO, ILLINOIS.

GAS-HEATED SAD-IRON.

1,000,497.

Specification of Letters Patent. Patented Aug. 15, 1911.

Application filed July 15, 1910. Serial No. 572,111.

To all whom it may concern:

Be it known that I, WILLIAM S. DARLEY, a citizen of the United States, residing at Chicago, county of Cook, and State of Illinois, have invented certain new and useful Improvements in Gas-Heated Sad-Irons, of which the following is a specification.

My invention relates to improvements in gas heated sad irons and has for its object the provision of such an iron which shall be of simple and economical construction and efficient in its operation.

The invention consists in the combination and arrangement of parts hereinafter described and claimed.

The invention will be best understood by reference to the accompanying drawings forming a part of this specification, and in which,

Figure 1 is a sectional elevation of a sad iron embodying my invention, Fig. 2 is a section taken on line $x-x$ of Fig. 1, Fig. 3 is a section taken on line $y-y$ of Fig. 1, and Fig. 4 is a section taken on line $z-z$ of Fig. 1.

The preferred form of construction as illustrated in the drawings comprises a hollow body 1 provided with air admission openings 2 extending from the top of the back portion of said body nearly to the bottom thereof. Ventilating openings 3 are also provided at the upper forward portions of each of the side walls and serve to permit escape of the burned gases. The lower central portion of the rear wall of body 1 is provided with an inwardly extending boss 4 having a forwardly and downwardly extending cylindrical opening 5 passing therethrough and covered at its inner end by wire gauze 6. A mixing tube 7 of a size to snugly fit opening 5 is inserted in said opening the same being provided with air admission openings 8 in its sides. A split sleeve 9 is frictionally mounted upon tube 7 and is adapted to slide longitudinally thereon to regulate the extent of the air admission openings 8. At its outer end sleeve 9 is provided with an enlargement or bell 10 adapted to protect openings 8 from drafts but admit air thereto. The outer end of tube 7 is threaded for the reception of a threaded plug 11 which serves as a means for securing the gas tube thereto.

Within body 1 is mounted a convex deflector plate 12 resting at its rear end upon

boss 4 and secured thereto by a set screw 13 threaded into said boss and contacting with mixing tube 7, thus serving the double purpose of holding said plate and mixing tube in position. At its forward end plate 12 is provided with an upwardly inclined lip 14 resting upon an inwardly extending projection 15 in body 1. At each side plate 12 is provided with positioning notches 16 adapted to engage inwardly extending projections 17 on each side of body 1. The bottom of body 1 on the inside is provided with upwardly extending diamond projections 18 forming diagonal grooves which serve to disseminate the heat and burning gases uniformly throughout the bottom of body 1.

Body 1 is provided with a cover plate 19 secured at the front and rear by means of set screws 20. Secured to cover plate 19 is a handle member 21 having a rear bridge 22 contacting with the top of cover plate 19 and a front projection 23 resting in a recess or socket 24 in said cover plate. A set screw 25 passing through the bottom portion of member 21 and threaded into cover plate 19 serves as a means for securing said handle member in position on said cover plate. A handle 26 is secured in handle member 21.

By this construction it will be observed that the burning gases in the iron entering through mixing tube 7 will be projected downwardly and forwardly over the bottom of the inside of body 1 and uniformly distributed thereover. By extending air admission openings 2 well toward the bottom of the rear of said body and providing the diamond shaped projections 18 on the bottom thereof ample air is admitted for combustion and the same is uniformly distributed to and under the burning gases through the oblique channels formed between said diamond shaped projections. The general construction is simple and economical of manufacture.

While I have illustrated and described the preferred form of construction for carrying my invention into effect this is capable of variation or modification without departing from the spirit of the invention. I therefore do not wish to be limited to the exact details set forth, but desire to avail myself of such variations and modifications as come within the scope of the appended claims.

Having described my invention what I

claim as new and desire to secure by Letters Patent is:

1. In a gas heated sad iron, the combination of a hollow body provided with a fuel inlet at the rear lower portion thereof and having ventilating openings at each side of said inlet and at the upper forward portions, the fuel inlet comprising an inwardly extending boss having a forwardly and downwardly extending cylindrical opening therein; a fuel mixing tube inserted in said opening; a downwardly and forwardly inclined deflector plate resting at the rear upon said boss and provided at its forward end with an upwardly inclined lip; an inwardly extending portion at the forward end of said body arranged to support said lip; a set screw passing through said deflector plate and into said boss to contact with said mixing tube; and diamond shaped projections on the bottom of the inside of said body, substantially as described.

2. In a gas heated sad iron, the combination of a hollow body provided with a fuel inlet at the rear lower portion thereof and having ventilating openings at each side of said inlet and at the upper forward por-

tions, the fuel inlet comprising an inwardly extending boss having a forwardly and downwardly extending cylindrical opening therein; a fuel mixing tube inserted in said opening; a downwardly and forwardly inclined convex deflector plate resting at the rear upon said boss and provided at its forward end with an upwardly inclined lip, the said deflector plate being notched at each side; an inwardly extending projection at the forward end of said body arranged to support said lip; inwardly extending projections on the sides of said body arranged to enter the notches in the sides of said deflector plate; a set screw passing through said deflector plate and into said boss to contact with said mixing tube; and diamond shaped projections on the bottom of the inside of said body, substantially as described.

In testimony whereof I have signed my name to this specification in the presence of two subscribing witnesses.

WILLIAM S. DARLEY.

Witnesses:

HELEN F. LILLIS,
JOSHUA R. H. POTTS.