

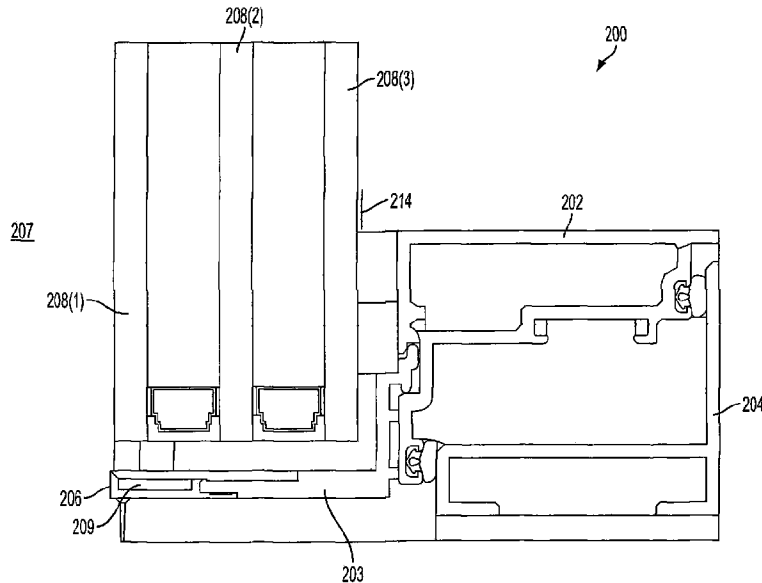

(86) **Date de dépôt PCT/PCT Filing Date:** 2013/03/13
 (87) **Date publication PCT/PCT Publication Date:** 2013/12/05
 (45) **Date de délivrance/Issue Date:** 2020/05/05
 (85) **Entrée phase nationale/National Entry:** 2014/11/24
 (86) **N° demande PCT/PCT Application No.:** US 2013/031075
 (87) **N° publication PCT/PCT Publication No.:** 2013/180805
 (30) **Priorité/Priority:** 2012/05/30 (US61/652,968)

(51) **Cl.Int./Int.Cl. E06B 3/263** (2006.01)
 (72) **Inventeur/Inventor:**
 BENES, PHILIP M., US
 (73) **Propriétaire/Owner:**
 OLDCASTLE BUILDINGENVELOPE INC., US
 (74) **Agent:** RIDOUT & MAYBEE LLP

(54) **Titre : PROCÉDE ET SYSTÈME D'ISOLATION DE COMPOSANTS STRUCTURAUX DE BATIMENTS**
 (54) **Title: METHOD AND SYSTEM FOR INSULATING STRUCTURAL BUILDING COMPONENTS**



(57) **Abrégé/Abstract:**

In one aspect, the present invention relates to a structural assembly including a first frame member hingedly coupled to a second frame member. A support member extends outwardly from the first frame member. At least one glazing panel is disposed above the support member. A thermal clip is coupled to the support member. The thermal clip insulates the support member from a building exterior. The support member extends less than an entire length thereof and reduces loss of thermal energy from a building interior to the building exterior via the support member.

(12) INTERNATIONAL APPLICATION PUBLISHED UNDER THE PATENT COOPERATION TREATY (PCT)

(19) World Intellectual Property
Organization
International Bureau(10) International Publication Number
WO 2013/180805 A1(43) International Publication Date
5 December 2013 (05.12.2013)(51) International Patent Classification:
E06B 3/263 (2006.01)(21) International Application Number:
PCT/US2013/031075(22) International Filing Date:
13 March 2013 (13.03.2013)

(25) Filing Language: English

(26) Publication Language: English

(30) Priority Data:
61/652,968 30 May 2012 (30.05.2012) US(71) Applicant: **OLDCASTLE BUILDINGENVELOPE
INC.** [US/US]; 803 Airport Road, Terrell, TX 75160 (US).(72) Inventor: **BENES, Philip, M.**; 3010 Kildeer Lane,
Wausau, WI 54401 (US).(74) Agents: **MOORE, Stanley, R.** et al.; Winstead PC, P.O.
Box 131851, Dallas, TX 75313 (US).(81) Designated States (unless otherwise indicated, for every
kind of national protection available): AE, AG, AL, AM,AO, AT, AU, AZ, BA, BB, BG, BH, BN, BR, BW, BY,
BZ, CA, CH, CL, CN, CO, CR, CU, CZ, DE, DK, DM,
DO, DZ, EC, EE, EG, ES, FI, GB, GD, GE, GH, GM, GT,
HN, HR, HU, ID, IL, IN, IS, JP, KE, KG, KM, KN, KP,
KR, KZ, LA, LC, LK, LR, LS, LT, LU, LY, MA, MD,
ME, MG, MK, MN, MW, MX, MY, MZ, NA, NG, NI,
NO, NZ, OM, PA, PE, PG, PH, PL, PT, QA, RO, RS, RU,
RW, SC, SD, SE, SG, SK, SL, SM, ST, SV, SY, TH, TJ,
TM, TN, TR, TT, TZ, UA, UG, US, UZ, VC, VN, ZA,
ZM, ZW.(84) Designated States (unless otherwise indicated, for every
kind of regional protection available): ARIPO (BW, GH,
GM, KE, LR, LS, MW, MZ, NA, RW, SD, SL, SZ, TZ,
UG, ZM, ZW), Eurasian (AM, AZ, BY, KG, KZ, RU, TJ,
TM), European (AL, AT, BE, BG, CH, CY, CZ, DE, DK,
EE, ES, FI, FR, GB, GR, HR, HU, IE, IS, IT, LT, LU, LV,
MC, MK, MT, NL, NO, PL, PT, RO, RS, SE, SI, SK, SM,
TR), OAPI (BF, BJ, CF, CG, CI, CM, GA, GN, GQ, GW,
ML, MR, NE, SN, TD, TG).

Published:

— with international search report (Art. 21(3))

(54) Title: METHOD AND SYSTEM FOR INSULATING STRUCTURAL BUILDING COMPONENTS

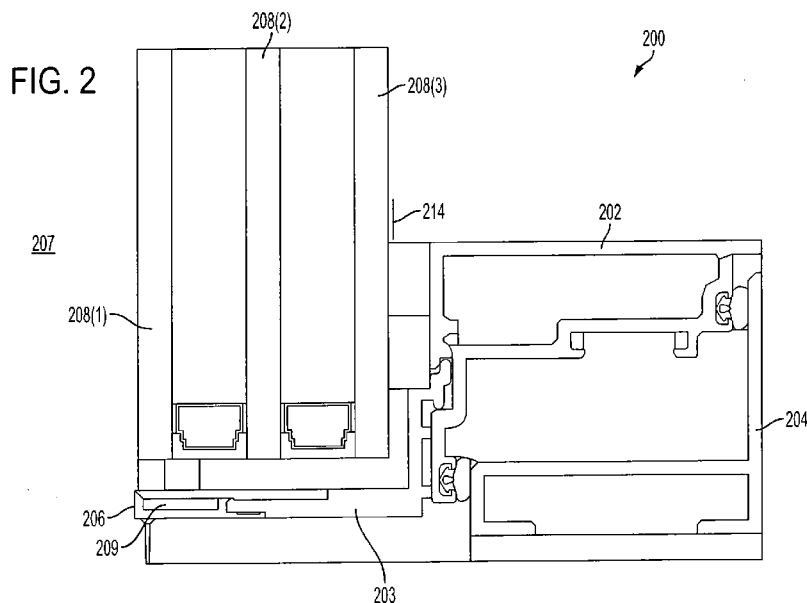

(57) Abstract: In one aspect, the present invention relates to a structural assembly including a first frame member hingedly coupled to a second frame member. A support member extends outwardly from the first frame member. At least one glazing panel is disposed above the support member. A thermal clip is coupled to the support member. The thermal clip insulates the support member from a building exterior. The support member extends less than an entire length thereof and reduces loss of thermal energy from a building interior to the building exterior via the support member.

 WO 2013/180805 A1

**METHOD AND SYSTEM FOR INSULATING STRUCTURAL BUILDING
COMPONENTS**

[0001]

BACKGROUND

Field of the Invention

[0002] The present application relates generally to structural building components and more particularly, but not by way of limitation, to methods and systems for thermal insulation of structural building members to reduce heat transfer.

History of the Related Art

[0003] The trend of increasing prices for natural gas, electricity, and other heating fuels have made energy efficiency a high-profile issue. In buildings, thermal energy may be lost to the atmosphere through, for example, radiation, convection, or conduction. Radiation is the transfer of thermal energy through electromagnetic waves. Convection takes place as a result of molecular movement, known as currents or convective looping, within fluids. A common mode of convection occurs as a result of an inverse relationship between a fluid's density and temperature. Typically, such type of convection is also referred to as "natural" or "free" convection where heating of a fluid results in a decrease in the fluid's density. Denser portions of the fluid fall while less dense portions of the fluid rise thereby resulting in bulk fluid movement. A common example of natural convection is a pot of boiling water in which hot (and less dense) water at a bottom of the pot rises in plumes and cooler (more dense) water near the top of the pot sinks. The primary means of thermal energy loss across an un-insulated air-filled space is natural convection.

[0004] Conduction is the transfer of thermal energy between regions of matter due to a temperature gradient. Heat is transferred by conduction when adjacent atoms vibrate against one another. Conduction is the most significant form of heat transfer within a solid or

between solid objects in thermal contact. Conduction is more pronounced in solids due to a network of relatively fixed spatial relationships between atoms. Thus, conductivity tends to vary with density. Metals such as, for example, copper and aluminum, are typically the best conductors of thermal energy.

[0005] Thermal efficiency of building components are often expressed in terms of thermal resistance ("R-value") and thermal transmission ("U-factor"). R-value is a measurement of thermal conductivity and measures a product's resistance to heat loss. In common usage, R-value is used to rate building materials such as, for example, insulation, walls, ceilings, and roofs that generally do not transfer significant amounts of heat by convection or radiation. A product with a higher R-value is considered more energy efficient.

[0006] Of particular concern in buildings are windows and doors. In particular, windows come in contact with the environment in ways that walls and solid insulation do not. As a result, windows are strongly affected by convection as well as radiation. For this reason, U-factor is commonly used as a measure of energy efficiency of windows. For example, U-factor measures a rate of total heat transfer through a product such as, for example, a window or a door (including heat transfer by convection and radiation). A product with a lower U-factor is considered more energy efficient. In recent years, federal, state, and municipal building codes often specify minimum R-values and maximum U-factors for building components.

SUMMARY

[0007] The present application relates generally to structural building components and more particularly, but not by way of limitation, to methods and systems for thermal insulation of structural building members to reduce heat transfer. In one aspect, the present invention relates to a structural assembly including a first frame member hingedly coupled to a second frame member. A support member extends outwardly from the first frame member. At least one glazing panel is disposed above the support member. A thermal clip is coupled to the support member. The thermal clip insulates the support member from a building exterior. The support member extends less than an entire length thereof and reduces loss of thermal energy from a building interior to the building exterior via the support member.

[0008] In another aspect, the present invention relates to a method for improving thermal performance of a structural assembly. The method includes forming a first frame member and coupling the first frame member to a second frame member. The method further includes forming a support member extending outwardly from the first frame member and disposing at least one glazing panel above the support member such that the support member extends less than an entire length thereof. The method further includes coupling the support member to a thermal clip. The thermal clip reduces loss of thermal energy to a building exterior via the support member.

BRIEF DESCRIPTION OF THE DRAWINGS

[0009] For a more complete understanding of the present invention and for further objects and advantages thereof, reference may now be had to the following description taken in conjunction with the accompanying drawings in which:

[00010] FIGURE 1 is a cross-sectional view of a prior-art structural assembly;

[00011] FIGURE 2 is a cross-sectional view of a structural assembly according to an exemplary embodiment;

[00012] FIGURES 3A-3D are cross-sectional views of various embodiments of a thermal clip;

[00013] FIGURE 4 is a cross-sectional view of a structural assembly illustrating use of the thermal clip of FIGURE 3B in a triple-glazed application according to an exemplary embodiment;

[00014] FIGURE 5A is an isometric view of a structural assembly illustrating use of the thermal clip of FIGURE 3B in a double-glazed application according to an exemplary embodiment;

[00015] FIGURE 5B is a cross-sectional view of the structural assembly of FIGURE 5A according to an exemplary embodiment; and

[00016] FIGURE 6 is a flow diagram illustrating a process for improving thermal

performance of the structural assembly of FIGURE 2 according to an exemplary embodiment.

DETAILED DESCRIPTION

[00017] Various embodiments of the present invention will now be described more fully with reference to the accompanying drawings. The invention may, however, be embodied in many different forms and should not be construed as limited to the embodiments set forth herein.

[00018] FIGURE 1 is cross-sectional view of a prior-art structural assembly 100. The structural assembly 100 includes a first frame member 102 coupled to a second frame member 104. The first frame member 102 is typically hingedly coupled to the second frame member 104; however, other forms of connection may be utilized depending on design requirements. A support member 103 extends outwardly from the first frame member 102. A plurality of glazing panels 108(1)-(3) are disposed above the support member 103. An insulator 106 is attached to an end of the support member 103. In a typical embodiment, the insulator 106 is constructed at least in part of a non-thermally-conductive material. As shown in FIGURE 1, the support member 103 extends substantially entirely underneath the plurality of glazing panels 108(1)-(3).

[00019] During operation, the structural assembly 100 is disposed between a building exterior 110, at a first temperature (t_1), and a building interior 112, at a second temperature (t_2). In applications where the first temperature (t_1) is substantially lower than the second temperature (t_2), such as for, example, 70 degrees Fahrenheit or more, thermal energy is conducted from warmer portions of the structural assembly 100 near the building interior 112 to cooler portions of the structural assembly 100 near the building exterior 110. Such conduction results in loss of thermal energy to the building exterior via the support member 103. By way of example, a temperature of the structural assembly 100 at point 114 is shown to be 41.7 degrees Fahrenheit.

[00020] FIGURE 2 is a cross-sectional view of a structural assembly 200 according to an exemplary embodiment. The structural assembly 200 includes a first frame member 202 coupled to a second frame member 204. In a typical embodiment, the first frame member 202 is hingedly coupled to the second frame member 204; however, in other embodiments, other forms of connection may be utilized depending on design requirements. A support member 203

extends outwardly from the first frame member 202. In the embodiment shown in FIGURE 2, the first frame member 202 and the support member 203 are separate elements; however, in other embodiments, structural assemblies utilizing principles of the invention may include a support member and a first frame member that are unitary. A plurality of glazing panels 208(1)-(3) are disposed above the support member 203. As shown in FIGURE 2, the support member 203 extends less than an entire length underneath the plurality of glazing panels 208(1)-(3). In a typical embodiment, the plurality of glazing panels 208(1)-(3) are, for example, structural glass, however, in other embodiments, the plurality of glazing panels 208(1)-(3) may be granite, slate, or other material as dictated by design requirements. A thermal clip 206 is coupled to an end of the support member 203. In a typical embodiment, the thermal clip 206 is constructed from a non-thermally-conductive material such as, for example, plastic, rubber, fiberglass, or other appropriate material as dictated by design requirements. The thermal clip at 206 has an air gap 209 formed therein. The air gap 209 insulates the support member 203 from a building exterior 207 and reduces loss of thermal energy to the building exterior 207 via the support member 203. In contrast to FIGURE 1, the temperature of the structural assembly 200 at point 214 is shown by way of example to be 49.4 degrees Fahrenheit. Thus, use of the thermal clip 206 improves thermal performance of the structural assembly 200.

[00021] FIGURE 3A is a cross-sectional view of the thermal clip 206 according to an exemplary embodiment. The thermal clip 206 includes a top member 302, a bottom member 304, an outer cross member 306, and an inner cross member 308. The air gap 209 is defined by the top member 302, the bottom member 304, the outer cross member 306, and the inner cross member 308. The air gap 209 insulates the support member 203 from a building exterior 207 and reduces loss of thermal energy to the building exterior 207 via the support member 203. Weather stripping 310 is disposed below the thermal clip 206 and operatively coupled to the bottom member 304. In a typical embodiment, the weather stripping 310 is constructed from, for example, a flexible material such as, for example, soft plastic. In a typical embodiment, the weather stripping 310 is co-extruded with the thermal clip 206 and prevents infiltration of fluid such as, for example, water into an area underneath the support member 203 (shown in FIGURE 2). In other embodiments, the thermal clip 206 is solid and the air gap 209 is omitted.

[00022] FIGURE 3B is a cross-sectional view of a thermal clip 350 according to an exemplary embodiment. The thermal clip 350 includes a top member 352, a bottom member 354, an outer cross member 356, and an inner cross member 358. An air gap 359 is defined by the top member 352, the bottom member 354, the outer cross member 356, and the inner cross member 358. The air gap 359 insulates the support member 203 from a building exterior 207 and reduces loss of thermal energy to the building exterior 207 via the support member 203. A slot 360 is formed in the bottom member 354. Weather stripping 362 is inserted into the slot 360. In a typical embodiment, the weather stripping 362 prevents infiltration of fluid such as, for example, water into an area underneath the support member 203 (shown in FIGURE 2). In other embodiments, the thermal clip 350 is solid and the air gap 359 is omitted.

[00023] FIGURE 3C is a cross-sectional view of a thermal clip 370 according to an exemplary embodiment. The thermal clip 370 includes a top member 372, a bottom member 374, an outer cross member 376, and an inner cross member 378. An air gap 380 is defined by the top member 372, the bottom member 374, the outer cross member 376, and the inner cross member 378. The air gap 380 insulates the support member 203 from a building exterior 207 and reduces loss of thermal energy to the building exterior 207 via the support member 203. In other embodiments, the thermal clip 370 is solid and the air gap 380 is omitted. A receptor 382 is formed in an end of the thermal clip 370 and is defined by the top member 372 and the bottom member 374. An edge protector 384 is inserted into the receptor 382. The edge protector 384 extends generally perpendicular upwardly from the top member 372. In a typical embodiment, the edge protector 384 protects the plurality of glazing panels 208(1)-(3) (shown in FIGURE 2) disposed above the thermal clip 370. In various embodiments, the edge protector 384 also functions as a gasket seal between the first frame member 202 and the second frame member 204 when the first frame member is in the closed position.

[00024] FIGURE 3D is a cross-sectional view of a thermal clip 390 according to an exemplary embodiment. The thermal clip 390 includes a top member 392, a bottom member 394, an outer cross member 396, and an inner cross member 398. An air gap 391 is defined by the top member 392, the bottom member 394, the outer cross member 396, and the inner cross member 398. The air gap 391 insulates the support member 203 from a building exterior 207

and reduces loss of thermal energy to the building exterior 207 via the support member 203. In other embodiments, the thermal clip 390 is solid and the air gap 391 is omitted. A slot 393 is formed in the bottom member 394. Weather stripping 395 is inserted into the slot 393. In a typical embodiment, the weather stripping 395 prevents infiltration of fluid such as, for example, water into an area underneath the support member 203 (shown in FIGURE 2). An edge protector 397 extends upwardly from the top member 392 in a generally perpendicular fashion. In a typical embodiment, the edge protector 397 is constructed from, for example, a soft plastic. In a typical embodiment, the edge protector 397 is co-extruded with the thermal clip 390. In other embodiments, structural assemblies utilizing principles of the invention may include thermal clips having any combination of the features described in FIGURES 3A-3D.

[00025] FIGURE 4 is a cross-sectional view of a structural assembly 400 illustrating the thermal clip 350 according to an exemplary embodiment. The structural assembly 400 is similar to the structural assembly 200 discussed above in FIGURE 2. The structural assembly 400 includes a first frame member 402 coupled to a second frame member 404. In a typical embodiment, the first frame member 402 is hingedly coupled to the second frame member 404; however, in other embodiments, other forms of connection may be utilized depending on design requirements. A support member 403 extends outwardly from the first frame member 402. In the embodiment shown in FIGURE 4, the first frame member 402 and the support member 403 are separate elements; however, in other embodiments, structural assemblies utilizing principles of the invention may include a support member and a first frame member that are unitary. A plurality of glazing panels 408(1)-(3) are disposed above the support member 403. As shown in FIGURE 4, the support member 403 extends less than an entire length under the plurality of glazing panels 408(1)-(3). The embodiment shown in FIGURE 4 illustrates three glazing panels 408(1)-(3); however, in other embodiments structural assemblies utilizing principles of the invention may include a different number of glazing panels. The thermal clip 350 is coupled to an end of the support member 403. In a typical embodiment, the thermal clip 350 is constructed, at least in part, of a non-thermally-conductive material. The weather stripping 362 is inserted into the slot 360 formed on the bottom member 354 of the thermal clip 350. In a typical embodiment, the weather stripping 362 prevents infiltration of fluid under the support member 403. The air gap 359 present in the thermal clip 350 insulates the support member 403 from a

building exterior 412 and reduces loss of thermal energy to the building exterior 412 via the support member 403.

[00026] FIGURE 5A is an isometric view of a structural assembly 500 illustrating use of the thermal clip 350 in a double-glazed application. FIGURE 5B is a cross-sectional view of the structural assembly of FIGURE 5A. The structural assembly 500 includes a first frame member 502 coupled to a second frame member 504. In a typical embodiment, the first frame member 502 is hingedly coupled to the second frame member 504; however, in other embodiments, other forms of connection may be utilized depending on design requirements. A support member 503 extends outwardly from the first frame member 502. In the embodiment shown in FIGURE 5, the first frame member 502 and the support member 503 are separate elements; however, in other embodiments, structural assemblies utilizing principles of the invention may include a support member and a first frame member that are unitary. A plurality of glazing panels 508(1)-(2) are disposed above the support member 503. As shown in FIGURE 5, the support member 503 extends less than an entire length under the plurality of glazing panels 508(1)-(2). The embodiment shown in FIGURE 5 illustrates two glazing panels 508(1)-(2); however, in other embodiments structural assemblies utilizing principles of the invention may include a different number of glazing panels. The thermal clip 350 is coupled to an end of the support member 503. The weather stripping 362 is inserted into the slot 360 formed on the bottom member 354 of the thermal clip 350. In a typical embodiment, the weather stripping 362 prevents infiltration of fluid under the support member 503. The air gap 359 insulates the support member 503 from a building exterior 512 and reduces loss of thermal energy to the building exterior 512 via the support member 503.

[00027] FIGURE 6 is a flow diagram illustrating a process for improving thermal performance of a structural assembly. A process 600 begins a step 602. At step 604 a first frame member 202 is formed and coupled to a second frame member 204. At step 606 a support member 203 is formed that extends outwardly from the first frame member 202. At step 608, a plurality of glazing panels 208(1)-(3) are disposed above the support member 203. At step 610, the support member 203 is coupled to a thermal clip 206. The thermal clip 206 has an air gap 209 formed therein. Although step 608 is described herein as preceding step 610, in other

embodiments, step 610 may precede step 608 depending on design requirements. At step 612, the air gap 209 present in the thermal clip 206 insulates the support member from the building exterior 207 and reduces loss of thermal energy to the building exterior 207 via the support member 203. The process 600 ends at step 614. Although FIGURE 6 is described with reference to the structural assembly 200, one skilled in the art will recognize that the process 600 described in FIGURE 6 could be utilized with the structural assembly 400, the structural assembly 500, or any other embodiment not specifically illustrated herein. Furthermore, while FIGURE 6 is described with reference to the thermal clip 206, one skilled in the art will recognize that the process 600 illustrated in FIGURE 6 could utilize the thermal clip 350, the thermal clip 370, and the thermal clip 390.

[00028] Although various embodiments of the method and system of the present invention have been illustrated in the accompanying Drawings and described in the foregoing Specification, it will be understood that the invention is not limited to the embodiments disclosed, but is capable of numerous rearrangements, modifications, and substitutions without departing from the spirit and scope of the invention as set forth herein. It is intended that the Specification and examples be considered as illustrative only.

What is claimed is:

1. A structural assembly comprising:
 - a first frame member hingedly coupled to a second frame member;
 - a support member extending outwardly from the first frame member;
 - at least one glazing panel disposed above the support member;
 - a thermal clip coupled to the support member and extending outwardly from the support member, the thermal clip insulating the support member from a building exterior, the thermal clip comprising:
 - a top member;
 - a bottom member;
 - an outer cross member coupling the top member to the bottom member;
 - an inner cross member coupling the top member to the bottom member; and
 - an air gap defined by the top member, the bottom member, the outer cross member, and the inner cross member; and
 - wherein the support member does not extend entirely underneath the at least one glazing panel and reduces loss of thermal energy from a building interior to the building exterior.
2. The structural assembly of claim 1, comprising a weather strip extending outwardly from the thermal clip.
3. The structural assembly of claim 2, wherein the weather strip is co-extruded with the thermal clip.
4. The structural assembly of claim 2, wherein the weather strip is received into a slot formed in the thermal clip.
5. The structural assembly of claim 1, comprising an edge protector extending outwardly from the thermal clip.
6. The structural assembly of claim 5, wherein the edge protector is received into a receptor formed in the thermal clip, the receptor being defined by the top member and the bottom member.

7. The structural assembly of claim 5, wherein the edge protector extends generally upwardly from the top member and protects the at least one glazing panel.
8. The structural assembly of claim 5, wherein the edge protector is co-extruded with the thermal clip.
9. The structural assembly of claim 5, wherein the edge protector seals a space between the first frame member and the at least one glazing panel.
10. A method for improving thermal performance of a structural assembly, the method comprising:
 - forming a first frame member;
 - coupling the first frame member to a second frame member;
 - forming a support member extending outwardly from the first frame member;
 - disposing at least one glazing panel above the support member; and
 - coupling the support member to a thermal clip, the thermal clip comprising:
 - a top member;
 - a bottom member;
 - an outer cross member coupling the top member and the bottom member;
 - an inner cross member coupling the top member and the bottom member; and
 - wherein the thermal clip reduces loss of thermal energy to a building exterior via the support member.
11. The method of claim 10, comprising forming an air gap within the thermal clip.
12. The method of claim 11, wherein the air gap isolates the support member from the building exterior.
13. The method of claim 10, comprising inserting a weather strip into a slot formed on the thermal clip.
14. The method of claim 10, comprising co-extruding a weather strip with the thermal clip.
15. The method of claim 10, comprising inserting an edge protector into a slot formed

on the thermal clip.

16. The method of claim 10, comprising co-extruding an edge protector with the thermal clip.

17. The method of claim 10, comprising sealing a space between the first frame member and the at least one glazing panel via an edge protector.

18. The method of claim 10, wherein the thermal clip is constructed of a thermally non-conductive material.

19. The method of claim 10, wherein the first frame member is hingedly coupled to the second frame member.

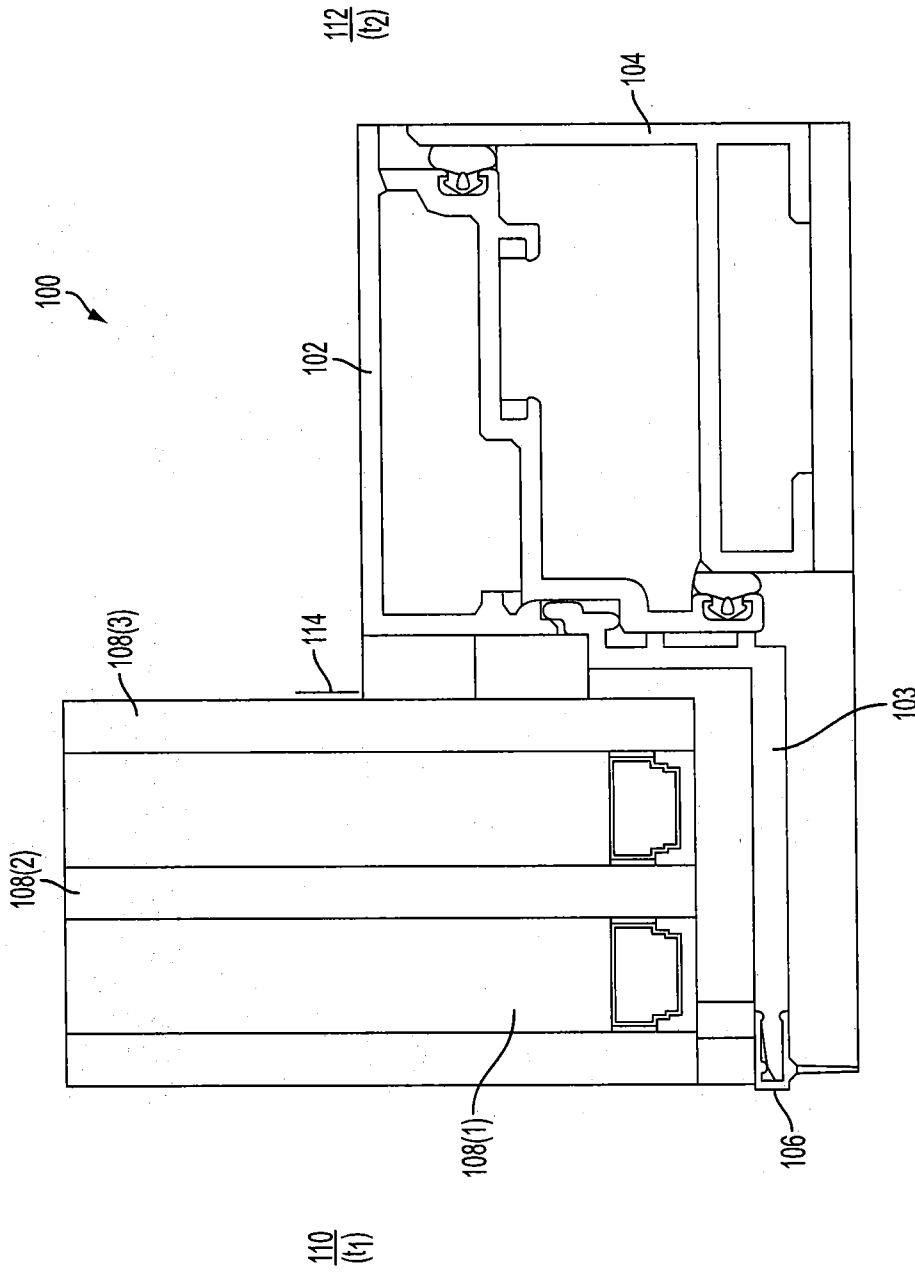

FIG. 1
PRIOR ART

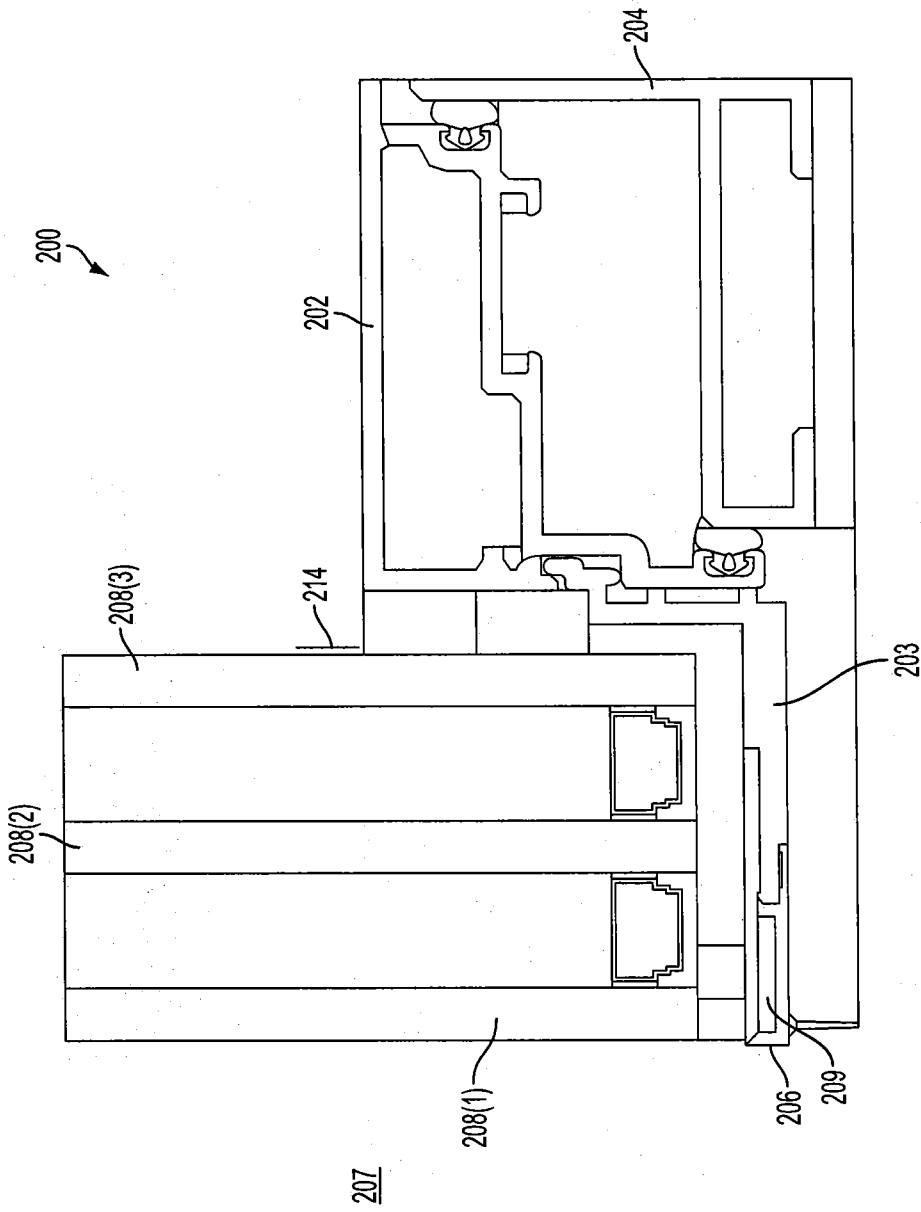

FIG. 2

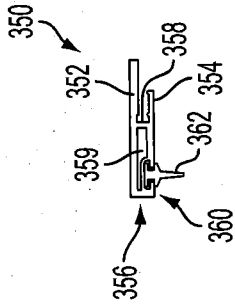

FIG. 3A

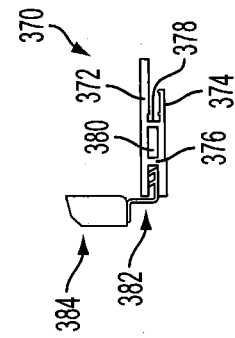

FIG. 3B

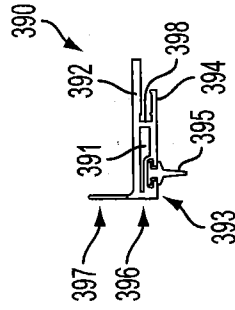

FIG. 3C

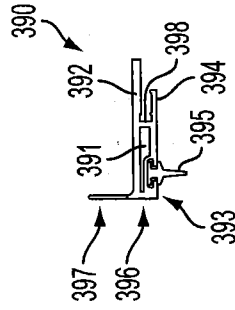

FIG. 3D

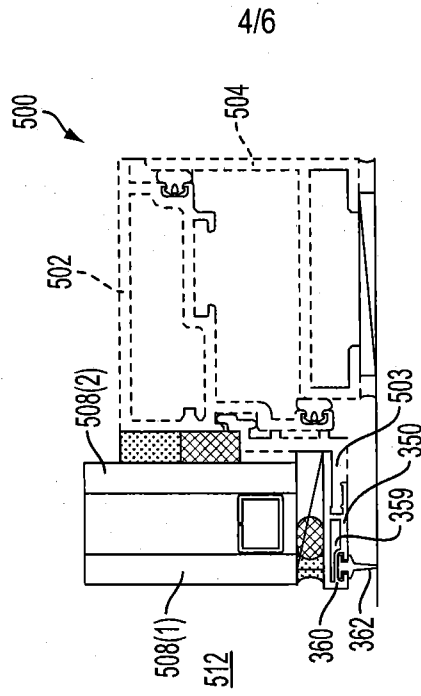

FIG. 5B

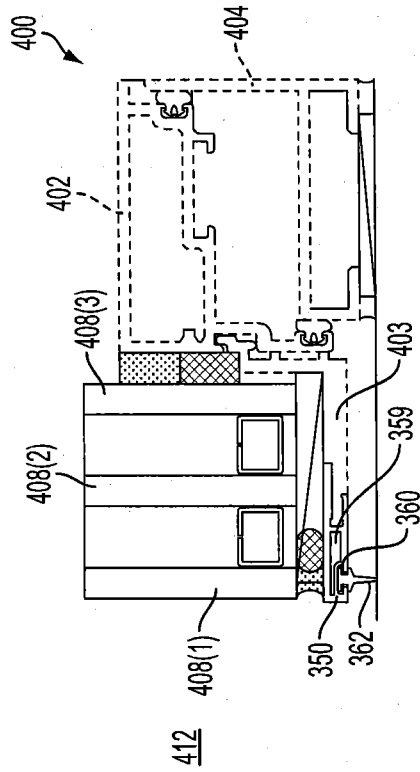

FIG. 4

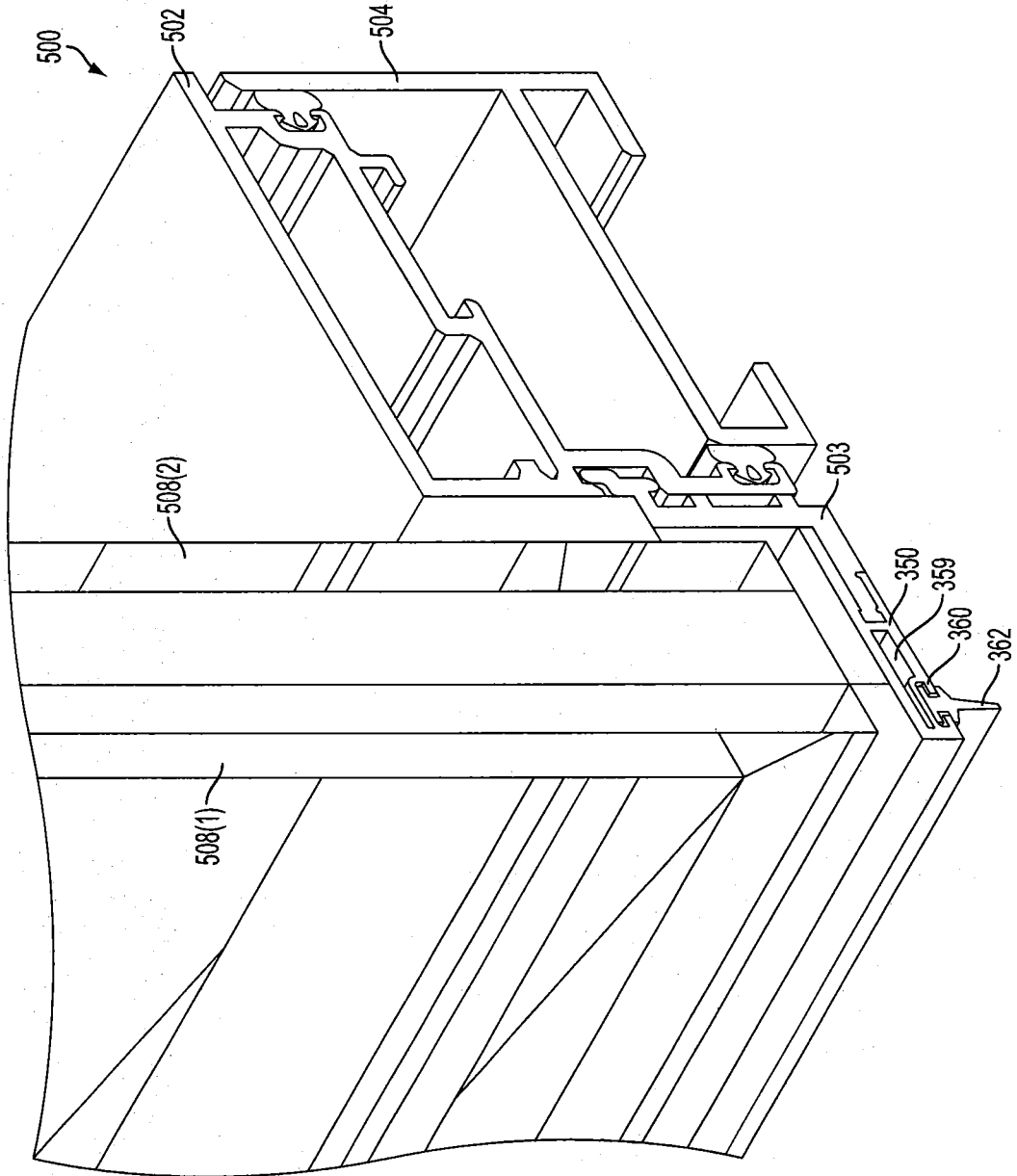

FIG. 5A

6/6

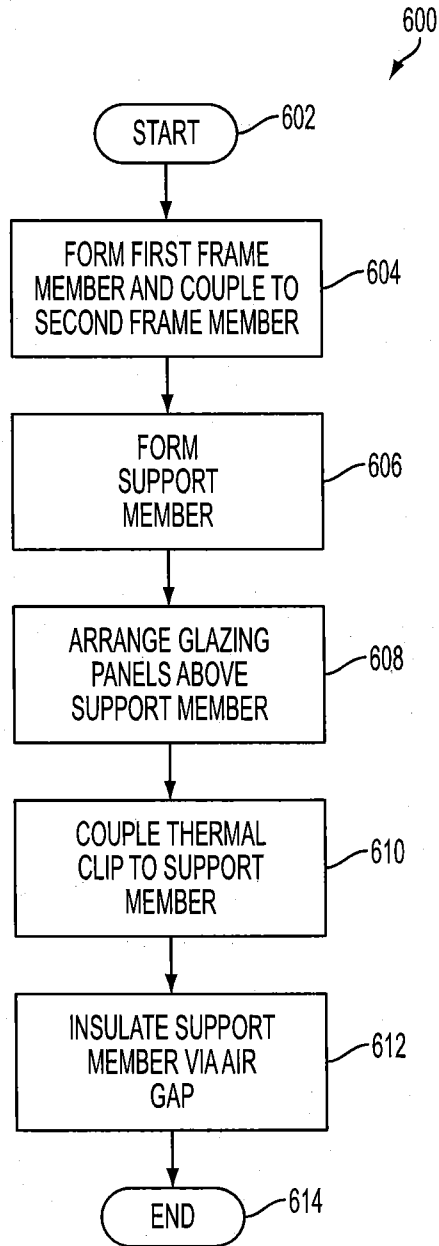

FIG. 6

