

(19) World Intellectual Property Organization
International Bureau



(43) International Publication Date
21 June 2007 (21.06.2007)

PCT

(10) International Publication Number
WO 2007/070332 A2

- (51) International Patent Classification:
B65D 65/46 (2006.01) B65D 81/32 (2006.01)
- (21) International Application Number:
PCT/US2006/046699
- (22) International Filing Date:
7 December 2006 (07.12.2006)
- (25) Filing Language: English
- (26) Publication Language: English
- (30) Priority Data:
11/303,070 14 December 2005 (14.12.2005) US
- (71) Applicant (for all designated States except US): KIMBERLY-CLARK WORLDWIDE, INC. [US/US]; 401 N. Lake Street, Neenah, Wisconsin 54956 (US).
- (72) Inventors; and
- (75) Inventors/Applicants (for US only): SOJKA, Marci, E. [US/US]; 2179 E. Prairie Creek Drive, Neenah, Wisconsin 54956 (US). BAUER, Walter, G. [US/US]; 7369 Sun Burst Lane, Neenah, Wisconsin 54956 (US). PRZEPASNIAK, Ann Marie [US/US]; 1205 Forest Edge Court, Wexford, Pennsylvania 15090 (US). CHRISTOFFEL, Sarah, L. [US/US]; W5771 Hearthstone Drive, Appleton, Wisconsin 54915 (US).

- (74) Agents: PUGLIESE, III, Sebastian, C. et al.; KIMBERLY-CLARK WORLDWIDE, INC., 401 N. Lake Street, Neenah, Wisconsin 54956 (US).
- (81) Designated States (unless otherwise indicated, for every kind of national protection available): AE, AG, AL, AM, AT, AU, AZ, BA, BB, BG, BR, BW, BY, BZ, CA, CH, CN, CO, CR, CU, CZ, DE, DK, DM, DZ, EC, EE, EG, ES, FI, GB, GD, GE, GH, GM, GT, HN, HR, HU, ID, IL, IN, IS, JP, KE, KG, KM, KN, KP, KR, KZ, LA, LC, LK, LR, LS, LT, LU, LV, LY, MA, MD, MG, MK, MN, MW, MX, MY, MZ, NA, NG, NI, NO, NZ, OM, PG, PH, PL, PT, RO, RS, RU, SC, SD, SE, SG, SK, SL, SM, SV, SY, TJ, TM, TN, TR, TT, TZ, UA, UG, US, UZ, VC, VN, ZA, ZM, ZW.
- (84) Designated States (unless otherwise indicated, for every kind of regional protection available): ARIPO (BW, GH, GM, KE, LS, MW, MZ, NA, SD, SL, SZ, TZ, UG, ZM, ZW), Eurasian (AM, AZ, BY, KG, KZ, MD, RU, TJ, TM), European (AT, BE, BG, CH, CY, CZ, DE, DK, EE, ES, FI, FR, GB, GR, HU, IE, IS, IT, LT, LU, LV, MC, NL, PL, PT, RO, SE, SI, SK, TR), OAPI (BF, BJ, CF, CG, CI, CM, GA, GN, GQ, GW, ML, MR, NE, SN, TD, TG).

Published:
— without international search report and to be republished upon receipt of that report

[Continued on next page]

(54) Title: WATER-DISPERSIBLE DEVICE WITH PULL TAB ACTIVATION

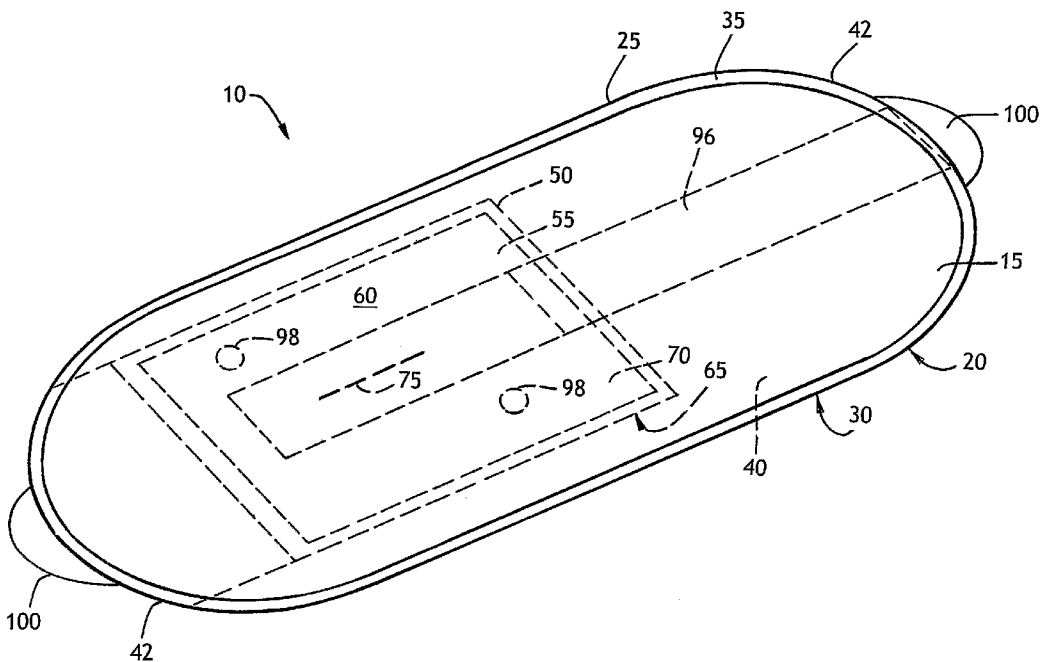

(57) Abstract: Provided is a device including a water-dispersible base layer; a water-dispersible wipe layer attached to the base layer at a seam and defining an interior space between the wipe and base layers, the interior space having an internal surface; and a pouch positioned within the interior space, the pouch having a top layer, a bottom layer attached to the top layer to form a cavity therebetween, an opening in one of the top and bottom layers, and a pull tab attached to the pouch.

WO 2007/070332 A2



For two-letter codes and other abbreviations, refer to the "Guidance Notes on Codes and Abbreviations" appearing at the beginning of each regular issue of the PCT Gazette.

WATER-DISPERSIBLE DEVICE WITH PULL TAB ACTIVATION

BACKGROUND

This invention pertains to cleaning, absorbent, and application devices, and
5 containers for liquids.

Cleaning devices and other similar devices that include a fluid container
commonly include a bladder or liquid-containing pouch. Such pouches are
designed to burst along a frangible seam or portion when pressure is applied to the
device and therefore the pouch. Such devices are not selective and burst under
10 sufficient pressure, whether that pressure is applied intentionally by a user, or that
pressure is applied unintentionally during handling, shipping, or storage.

SUMMARY

Cleaning devices and other similar devices including bladders that contain
15 fluids suffer from the problem of premature bursting of such liquid containing
pouches. In addition, discarding of such a device as trash can leave a wet mess.

The invention disclosed herein solves the bursting and disposability
problems by providing a device including a soft flexible pouch of fluid constructed
from water-dispersible materials. The flexible pouch is durable and is designed to
20 not burst during normal handling.

More specifically, the invention disclosed herein provides a device including
a water-dispersible base layer; a water-dispersible wipe layer attached to the base
layer at a seam and defining an interior space between the wipe and base layers,
the interior space having an internal surface; and a pouch positioned within the
25 interior space, the pouch having a top layer, a bottom layer attached to the top
layer to form a cavity therebetween, an opening in one of the top and bottom
layers, and a pull tab attached to the pouch.

The invention disclosed herein also provides a device including a water-
dispersible base layer; a water-dispersible wipe layer attached to the base layer to
30 form an internal space therebetween; a means for containing a fluid positioned
within the internal space, and a means for unsealing the fluid-containing means,
wherein the unsealing means is activated by stretching one of the wipe and base
layers.

The invention described herein also provides a method for using a device, the method including producing a device including a water-dispersible base layer, a water-dispersible wipe layer attached to the base layer to form a seam and an interior space between the wipe and base layers, the interior space having an
5 internal surface, and a pouch positioned within the interior space, the pouch having a pull tab attached to the pouch. The method further includes activating the device by pulling the pull tab to open the pouch.

The invention described herein also provides a method for using a device, the method including producing a device including a water-dispersible base layer
10 and a water-dispersible wipe layer attached to the base layer at a seam and defining an interior space between the wipe and base layers, the interior space having an internal surface; and activating the device by stretching the device

The invention described herein also provides a device including a water-dispersible base layer; a water-dispersible wipe layer attached to the base layer at
15 a seam and defining an interior space between the wipe and base layers, the interior space having an internal surface; and a pouch positioned within the interior space and attached to one of the seam and the internal surface. The pouch has a top layer, a bottom layer attached to the top layer to form a cavity therebetween, an opening in one of the top and bottom layers, and a pull tab attached to the
20 pouch.

Objects and advantages of the present invention will become apparent to those skilled in the art in view of the following description and the accompanying drawings.

25 BRIEF DESCRIPTION OF THE DRAWINGS

Fig. 1 is a schematic perspective view of an aspect of the present invention.

DETAILED DESCRIPTION OF THE PREFERRED EMBODIMENTS

The aspects of the invention as described herein will be described for
30 exemplary purposes as a cleaning device. The aspects of the invention, however, apply equally to other forms of products, including absorbent devices, application devices, personal care devices, cosmetic devices, and other devices including

wipes, mops, mitts, and cleaning towels, among other devices, and to all suitable uses including cleaning, applying, and removing.

The term "surface" and its plural generally refer herein to the outer or the topmost boundary of an object. Surface may refer to that of skin, hair, clothing, upholstery, countertops, floors, walls, windows, tables, appliances, bathroom fixtures, automobiles, or any other object that may require or accommodate cleaning, removing something from, or applying something to its surface.

The term "stretchable" generally refers to the capability of a material to be either elastically or plastically extensible. An elastically extensible or elastically stretchable material is a material that is capable of extending upon application of a tensile force and capable of retracting either partially or close to completely to its original dimension(s) upon removal of the force. A plastically extensible material is a material that is capable of extension or deformation without breaking upon application of a tensile force, but does not substantially recover its original size and shape after removal of a force causing the extension or deformation.

The term "flushable" generally refers to an article that, when flushed down a conventional commode containing approximately room temperature water, will pass through the commode plumbing, the sewer laterals (i.e., the piping between the house or building and the main sewer line) without clogging, and disperse into pieces no larger than about 25 mm in diameter.

The term "dispersible" generally refers to a material in which the fibers of that material are capable of debonding or dissolving, resulting in the material breaking down into smaller pieces than the original sheet. Debonding is generally a physical change of scattering or separation. Dissolving is a state change, wherein the material goes into solution, e.g., a water soluble polymer dissolving in water.

The term "water dispersible" generally refers to a fibrous nonwoven composite structure which, when placed in an aqueous environment, will, with sufficient time, break apart into smaller pieces. As a result, the structure once dispersed may be more advantageously processible in recycling processes, for example, septic and municipal sewage treatment systems. If desired, such fibrous nonwoven structures may be made more water-dispersible or the dispersion may be hastened by the use of agitation and/or the selection of certain materials as

further described below. The actual amount of time will depend at least in part upon the particular end-use design criteria.

Fig. 1 illustrates an example of a cleaning device 10 as an aspect of the present invention. The device 10 includes a wipe layer 15 and a base layer 20.

5 For purposes of illustration, and not for purposes of limitation, the cleaning device 10 is described as a pad.

The device 10 includes a wipe layer 15. The wipe layer 15 may be of any suitable shape, but is preferably generally planar and is further preferably generally rectangular or oblong. The wipe layer 15 has a perimetric edge 25 extending
10 around the wipe layer 15. In one aspect of the present invention, the wipe layer 15 is generally the size of a human hand held flat on a surface. In another aspect of the present invention, the wipe layer 15 is generally the size of the four fingers of a human hand. In still another aspect of the present invention, the wipe layer 15 is generally the size of a human finger. The device 10 may be manufactured in any
15 shape or of any dimensions, including as a pad sized to fit best in a child's hand, an adult hand, or on any cleaning implement. In general, the wipe layer 15 may be of any suitable size, with the size preferably selected to be suitable for the intended use of the cleaning device 10. In other aspects of the present invention, the device 10 can be manufactured into other shapes such as a mitt or square or
20 round pads, or in any other geometry including rectangular, ovoid-like, elliptical, trapezoidal, butterfly, pear-shaped, heart-shaped, or a combination of these.

The wipe layer 15 is an active layer, which performs the cleaning function. In one aspect of the present invention, the wipe layer 15 is stretchable, and may be either elastically or plastically stretchable. The wipe layer 15 is provided for
25 comfort and flexibility and functions to direct bodily exudate(s) away from the body, or other fluids from the device 10 to the body. Flexible refers to materials that are compliant and readily conform to the bodily surfaces with which such materials are in contact, or materials that respond by easily deforming in the presence of external surfaces. The wipe layer 15 can be constructed of any woven or
30 nonwoven material that is easily penetrated by bodily fluids and from the ingredients inside the device 10. Examples of suitable wipe layer materials include bonded carded webs of polyester, polypropylene, polyethylene, nylon, or other heat bondable fibers, polyolefins, such as copolymers of polypropylene and

polyethylene, linear low density polyethylene, and aliphatic esters such as polylactic acid. Finely perforated film webs and net material can also be used. Other examples of suitable materials are composite materials of polymer and nonwoven fabric materials. The composite materials are typically in the form of
5 integrated sheets generally formed by the extrusion of a polymer onto a web of spunbonded material. The wipe layer 15 may also include a plurality of apertures formed therein that are extended to increase the rate at which ingredients can penetrate through the wipe layer 15. The wipe layer 15 may also be embossed with any desired embossing pattern.

10 In alternate aspects of the present invention, any suitable coform, nonwoven, or woven material may be used. In one aspect of the present invention, the wipe layer 15 is an absorbent material. The wipe layer 15 may be a stretch-bonded laminate (SBL) with pre-stretched elastic filament and meltblown material with one ply of spunbond material on each outer surface and a basis
15 weight of approximately 70 gsm, but any suitable absorbent material may be used. SBL and other composite nonwoven elastic webs are further described in U.S. Patent No. 4,657,802 to Morman. In one aspect of the present invention, the wipe layer 15 includes a dry embossed 110 grams per square meter (gsm) coform laminate available from Kimberly-Clark Corporation.

20 In other aspects of the present invention, materials for the wipe layer 15 may include various natural or synthetic fibers, multiple plies of creped cellulose wadding, fluffed cellulose fibers, rayon or other regenerated cellulose materials, wood pulp fibers or comminuted wood pulp fibers, cotton, airlaid material, textile fibers, a blend of polyester fibers and polypropylene fibers, absorbent foams,
25 absorbent sponges, superabsorbent polymers, coated superabsorbent polymers, fibrous bundles or nits, or any equivalent material or combination of materials. Hydrophobic materials are also suitable for use where hydrophobic material has been rendered hydrophilic according to any of a number of known methods for so doing. The material maybe formed of a nonwoven fabric that is made of
30 interbonded thermoplastic fibers. The fibers may be formed from a variety of thermoplastic materials including polyolefins (e.g., polyethylene or polypropylene), polystyrene, and polyamides (e.g., nylon). In addition, thermoplastic polymers that

are elastomeric may also be used as fibers, including polyurethanes and block copolymers. Blends of any of these materials may be used to form the fibers.

5 A flushable device is generally designed such that its size and manufacture facilitate flushing in conventional sewer and septic systems. Care must be taken such that the device does not obstruct or otherwise damage the sewer or septic system. Devices that tend to fragment into individual components before or during flushing may also tend to cause clogging of a structure's plumbing system. The more components or articles that travel through a home's contorted plumbing system per device flushed increases the risk that any one such component may become entrapped or entangled in bends, roots, or the like, as compared to a single intact device. Thus, a need exists for a device design that offers the benefits of a dispersible product without sacrificing performance of the device or adding to the risk of plumbing clogs or other problems upon flushing the device. Such dispersible devices may be disposed of by placing in a toilet and flushing.

15 The device of the present invention offers advantages over conventional devices. The device includes unique combinations of materials to produce initial neutral buoyancy and delayed sinking properties that result in safe transport of the intact device through plumbing and municipal systems. The devices should not substantially disperse or break apart during transport, and preferably sink within about 7 days after being flushed. Sinking within 7 days minimizes the chances of the device becoming clogged in septic tanks and from requiring removal in water treatment plants.

25 Even if the devices do not sink within 7 days, the neutral buoyancy will tend to prevent the devices from floating on the surface of the water stream and being forced over the tank baffle into the secondary chamber of conventional septic tanks with the effluent where they may be subsequently pumped into the drain field or possibly clog the system outlet resulting in a back-up of the system. In a waste treatment facility, neutrally buoyant devices will be intercepted by the screens or grinders prior to entering the water purification process.

30 Maintaining neutral buoyancy will allow the device to essentially skim near the top of the surface of the water while traveling through a toilet system, through a structure's lateral piping system, and out to the sewer stream without clogging in any of these systems. As the device travels to the sewer stream or septic tank and

suspended solid particles begin to collect on the device, the device will begin to travel between the bottom of the pipe and the water/air stream above it. Over time, the device should become negatively buoyant and sink to the bottom of the septic tank or to the bottom of the clarifying tank at the waste water treatment
5 plant.

Eventual sinking of the device will provide distinct advantages. First, as mentioned above, sinking will prevent the device from being carried into a septic tank's second chamber and possibly out to the septic tank's drain field. Sinking the device to the bottom of the septic tank will provide an opportunity for anaerobic
10 degradation of any natural materials, such as rayon or cotton. Sinking of the device will also reduce the chances of the device becoming noticed in municipal water treatment centers and in personal homes.

In another aspect of the present invention, the wipe layer 15 may be dispersible in water. Cellulosic fiber webs are generally considered dispersible in
15 water in that they readily fragment into individual fibers upon sufficient exposure to an aqueous environment. Various other water-dispersible absorbent materials are known to those skilled in the art and may be used with the present invention. For example, U.S. Patent Nos. 5,952,251 to Jackson et al. and 5,948,710 to Pomplun et al. describe absorbent dispersible conform materials that may be suitable for the
20 present invention, and are incorporated herein by reference. U.S. Patent No. 6,171,292 to Osborn et al. also discloses a number of dispersible absorbent materials that may be used with the present invention, and is incorporated herein by reference.

To be effective for use in cleaning and applicator devices, a dispersible wipe
25 layer 15 must be functional in use, i.e., maintain integrity in the presence of cleansing or other fluids, yet dissolve or disperse rapidly in water found in toilets. In one aspect of the invention, a triggerable material may be used. The main component of the triggerable material of the present invention is an ion-trigger polymer. An ion-trigger polymer is one whose strength and dispersibility in water is
30 changed depending on a very slight difference in the concentrations of a salt. More specifically, an ion-trigger polymer loses strength and disperses in tap water, but maintains strength and is insoluble in an aqueous solution that contains not

less than 0.5 percent by weight of a neutral inorganic salt comprising a monovalent ion such as NaCl, KCl, or NaBr.

It is well known that the addition of an inorganic salt to an aqueous solution of a water-soluble polymer may force polymer precipitation through a salting-out phenomenon. For example, anionic polymers such as sodium salts of polyacrylate and carboxymethyl cellulose become insoluble in an aqueous solution of common salt having a concentration of 4 to 5 percent or higher; non-ionic polymers such as hydroxyethyl cellulose and polyvinyl alcohol (PVA) are insoluble in an aqueous solution only when the concentration of the salt is increased to about 10 percent or higher. This salting out of a water soluble polymer describes the change from a homogeneous polymer solution to a polymer precipitate. While an ion-trigger polymer is certainly salt-sensitive, like the simple water-soluble polymers mentioned above, there are several significant differences in the behavior of an ion-trigger polymer for flushable applications. First, the ion-trigger polymer may be sensitive to changes in ion concentration at low levels, such as 0.5 percent by weight of a common salt. Second, in the aqueous ionic solutions of typical cleaning fluids, the ion-trigger polymer is expected not just to be insoluble, but is required to maintain integrity and strength. Finally, the ion-trigger polymer loses enough strength or integrity to disperse in tap water; but note that this dispersion does not necessarily require full dissolution, as would be typical with the simple salt-sensitive water-soluble polymers.

The feature of integrity and strength in use can be achieved by ensuring a proper hydrophobic/hydrophilic balance throughout the polymer chain. As used herein, the term "hydrophobic/hydrophilic balance" refers to a balance of hydrophobic and hydrophilic moieties along the polymer chain, which results in the polymer having a desired trigger property. By control of the hydrophobic/hydrophilic balance in the composition of the polymer, ion-sensitive polymers having desired in-use integrity and water-dispersibility are produced. In contrast, for simple salt-sensitive, water-soluble homopolymers like polyvinyl alcohol, the hydrophobic/hydrophilic character is fixed by the structure of the monomer, and cannot be adjusted.

In one formulation of the triggerable polymer, the ion-trigger character is provided by a sulfonated polyester condensation polymer. The

hydrophobic/hydrophilic balance can be controlled by choice of the monomers involved in the condensation reaction. The preparation of such polyesters is generally described, for example, in U.S. Patent Nos. 4,910,292 and 4,973,656 to Blount.

5 In addition to the sulfonated copolyesters, a variety of other trigger polymers are known in the art. U.S. Patent No. 5,770,528 to Mumick et al. reveals methylated hydroxypropyl cellulose as a polymer with trigger controlled by temperature and ion concentration. Hydroxypropyl cellulose itself has some ion-sensitivity, but is more of a temperature-trigger material.

10 U.S. Patent No. 5,509,913 to Yeo lists a variety of polymers, including polyvinyl methyl ether, polyvinyl alcohol, and various cellulose polymers with temperature triggers modulated by ion concentration. These temperature-trigger polymers may have limited utility in a triggerable fiber.

Water-soluble, ion-trigger polymers are also known. For example, U.S.
15 Patent Nos. 5,317,063 and 5,312,883 to Komatsu et al. reveal acrylic acid or methacrylic acid copolymers that are ion-sensitive. These materials are not melt processible, and so are not amenable to fiber production. Coating an aqueous solution of ion-trigger polymers on a water-insensitive polymer core is also possible.

20 It is suitable that the wipe layer 15 be made from conjugate fibers in a sheath/core configuration so that the core gives the fibers strength and the sheath bondability. Such fibers may be crimped or crimpable according to U.S. Patent No. 5,382,400 to Pike et al. One type of fiber to be used as the conjugate fiber has a polypropylene core and an outer sheath consisting of HB Fuller's NP2068 or NP
25 2074, Atochem's PEBAX MX 1074, Nippon Gohsei's Ecomaty AX10000, National Starch's 8824-71-1, 70- 4395, 70-4442 copolyesters and the blends of the polymers mentioned above with some other biodegradable polymers such as aliphatic polyesters. The suitable aliphatic polyesters include, but are not limited to, polybutylene succinate, polybutylene succinate adipate, polyhydroxybutyrate-
30 co-valerate, polycaprolactone, and polylactide and its copolymers, and the 80/20 blend of triggerable conjugate staple binder fibers mentioned above.

The conjugate fibers can be blended with other less expensive fibers in a number of known processes to reduce cost. The conjugate fiber may be blended

with less expensive fibers like polyolefins, polyester, rayon, etc., in amount of from about 10/90 to about 90/10, or more particularly about 50/50, by any suitable process. Examples of suitable processes include airlaying, coforming, and bonding and carding, after which the fibers may be bound together by, for
5 example, through-air bonding at an appropriate temperature. Liquid binders may also be used, such as Kymene® 557LX binder available from Hercules Inc. of Wilmington, DE. The less expensive fibers may be staple fibers which are typically 6 to 12 mm in length and about 1.5 denier so that they will not form long strands upon dispersion that could become caught on projections in the waste system
10 piping or other parts of the treatment facility, and cause clogs. The finished wipe layer 15 should be in the range of from about 10 to 500 gsm in basis weight or more particularly between about 20 and 30 gsm.

Multicomponent ionically triggerable fibers are provided in U.S. Patent No. 5,916,678 to Jackson et al. This provides a polymer fiber in which one component
15 comprises a water-dispersible polymer that remains stable in the presence of an aqueous solution having greater than about 1000 ppm of a kosmotrope and disperses in a period not exceeding 30 minutes in an aqueous solution having less than about 1000 ppm of a kosmotrope. In one example in this application, film samples formed from National Starch 70-4442 polymer were tested for dispersion
20 in deionized water as compared to commercially available bath tissue, substantially in accordance with "A Simple Test for Dispersion of Wet Chop Fiberglass in Water", published in the 1996 TAPPI Proceedings Nonwovens Conference and incorporated herein by reference. Five 1.5 inch (38.1 mm) long by 1.5 inch (38.1 mm) wide film samples (Sample 1) having an average weight of
25 0.2525 grams were placed in 1,500 ml of deionized water having a resistance greater than or equal to 18 megohms contained in a 2,000 ml Kimax beaker, No. 14005. A Fisher Scientific Stirrer (Magnetic), Catalog No.11 -498-78H, was set at a speed setting of 7 to agitate the contents of the beaker. Using a standard timer, the period of time was measured from the point the stirrer was activated until the
30 onset of dispersion occurred, which was defined as the point at which the first piece of sample film material broke off or away from the remaining portion of the film sample, and until full dispersion occurred, which was defined as the point at

which the sample film material had dispersed into pieces having diameters not exceeding about 0.25 inches (6.35 mm).

In another aspect of the present invention, the wipe layer 15 may be constructed from a laminate of a thin layer of airlaid material with a thin layer of flexible absorbent binder and starch with embedded salts and a thin layer of polyvinyl alcohol (PVA) film. In this aspect, the airlaid material provides the wipe layer 15 with integrity and softness, the PVA serves as the material holding the ingredients, and the starch is a dissolvable layer that will trigger the salt to escape upon contact with water to activate the reaction with the binder in the airlaid structure to disperse the airlaid material. The flexible absorbent binder is present to hold the airlaid and starch together until contact with water. In yet another aspect of the present invention, the wipe layer 15 may be constructed from highly biodegradable spunlace and PLA.

The fibers of the wipe layer 15 may include additives (e.g., wax, pigments, stabilizers, and fillers) that are inserted as the fibers are fabricated to achieve one or more desired properties within the fibers. Some example additives include compatible surfactants that are added to the polymers to make the surface of the fibers more wettable, thereby improving the ability of the fiber structure to attract unwanted debris away from the skin. The amount of surfactant added to the fibers can be adjusted to control the surface wetting of the fabric formed from the fibers. Examples of suitable surfactants include sodium dioctyl sulfosuccinate and alkyl phenoxy ethanol.

Material used in making the wipe layer 15 may be capable of capturing and/or storing substances within the material. Such material may store and/or capture debris, cleansers, lubricants, spermicidal agents, and medications, among other materials, before or while using the device 10. Examples of such materials include spunbond, spunlace, bonded carded web, and apertured film materials. In one aspect of the present invention, the material is an apertured film that is formed of a polyolefin that may be combined with a nonwoven fabric. In other aspects of the present invention, the material of the wipe layer 15 may be a laminate of like, similar, or different tissue, nonwoven, woven, or film materials, or of any other materials described herein.

When a nonwoven fabric is used, the basis weight of the nonwoven fabric may vary depending on the properties that are desired within the device 10. As an example, the basis weight for the nonwoven fabric may be as low as 10 gsm and as high as 300 gsm. Such nonwoven materials may include a textured surface.

5 Examples of such nonwoven textured materials include rush transfer materials, flocked materials, wireform nonwovens, and thermal point unbonded materials, among others.

In one aspect of the present invention, the wipe layer 15 may be used dry to absorb liquids from a surface. In another aspect of the present invention, the wipe
10 layer 15 may be dampened by a user with water or another substance to aid cleaning with the cleaning device 10.

The cleaning device 10 also includes a base layer 20. The base layer 20 is preferably of the same general size and shape of the wipe layer 15, although the size and/or shape of the base layer 20 may be selected to be different from the
15 size and/or shape of the wipe layer 15 based on the intended use of the cleaning device 10. The base layer 20 has a perimetric edge 30 extending around the perimeter of the base layer 20.

The base layer 20 may be a backing layer. The base layer 20 may be manufactured under any of the aspects of the present invention described above
20 for the wipe layer 15. The base layer 20 may be stretchable, and may be either elastically or plastically stretchable. The base layer 20 may be manufactured from any suitable nonwoven, woven, or paper tissue material. In one aspect of the present invention, the base layer 20 is an absorbent material. The base layer 20 may be SBL with pre-stretched filament and meltblown material with one ply of
25 spunbond material on each outer surface and a basis weight of approximately 70 gsm, but any suitable absorbent material may be used. In one aspect of the present invention, the base layer 20 includes a dry embossed 100 gsm coform laminate available from Kimberly-Clark Corporation.

In an alternative aspect of the present invention, the base layer 20 is also
30 an active layer and manufactured under any of the aspects of the present invention described above for the wipe layer 15. In the case of the base layer 20 as an active layer, the base layer 20 may be manufactured from a material similar to or different from that used for the wipe layer 15.

In an alternative aspect of the present invention, one or both of the wipe and base layers 15, 20 may be breathable to allow air to circulate through the device 10.

The wipe layer 15 is coupled to the base layer 20. One of the wipe and base layers 15, 20 is positioned to overlie the other of the wipe and base layers 15, 20, such that the perimetric edges 25, 30 of the wipe and base layers 15, 20 generally align. A portion of the perimetric edge 25 of the wipe layer 15 is attached to the perimetric edge 30 of the base layer 20 to form a seam 35. The seam 35 may be formed at the perimetric edges 25, 30, or the seam 35 may be adjacent or inward from the perimetric edges 25, 30. The wipe and base layers 15, 20 may be attached by adhesive, ultrasonic bonding, sonic bonding, heating, sewing, or by any other suitable method. In one aspect of the present invention, the wipe and base layers 15, 20 are attached using a block copolymer adhesive such as 34-5610 construction adhesive available from National Starch & Chemical Company, Bridgewater, NJ. The construction adhesive used to attach the wipe and base layers 15, 20 may also be stretchable. The wipe and base layers 15, 20 may also be attached at locations in addition to or other than the perimetric edges 25, 30. The construction adhesive may be formulated to ensure that the device 10 does not disperse or fragment into individual components until after the device 10 is exposed to an aqueous environment, such as after being dropped into a toilet and flushed.

Coupling the wipe layer 15 to the base layer 20 forms the device 10 with an interior space 40. The device 10 also includes opposed ends 42.

The base layer 20 may include a liquid impermeable barrier layer (not shown) facing the interior space 40. In one aspect of the present invention, the material of the barrier layer is a polyolefin-type material that can be heat sealed or ultrasonically sealed. In another aspect of the present invention, the material of the barrier layer is a material such as BSTL, a breathable, stretchable, thermal laminate. BSTL and similar materials are described in U.S. Patent Nos. 5,695,868 to McCormack et al. and 5,843,056 to Good et al. In yet another aspect of the present invention, the material of the barrier layer may be SBL as described above, or may be any other suitable material, particularly those described above with reference to the wipe layer 15. In one aspect of the present invention,

because the base layer 20 is the layer most likely to contact a user's hand, the barrier layer acts to keep the base layer 20 and thus the user's hand dry. In another aspect of the present invention, the user's hand or one or more fingers may be inserted between the barrier layer and the base layer 20, where the barrier layer again acts to keep the user's hand/finger(s) dry. The barrier layer may also be positioned adjacent a portion of the wipe layer 15 to occlude a portion of the wipe layer 15 from fluid contact, allowing that portion of the wipe layer 15 to remain dry. Separate barrier layers may also be positioned adjacent the base layer 20 and adjacent the wipe layer 15. In another aspect of the present invention, the base layer 20 and the barrier layer may be the same layer.

By virtues of the design and materials chosen for the device 10, the device 10 is preferably designed to be disposable. In this case, disposable means that the device 10 is disposed of, rather than cleaned, after use.

In an alternative aspect of the present invention, the wipe layer 15 and the base layer 20 are two portions of the same piece of material. One of the wipe layer 15 and the base layer 20 is folded over the other of the wipe layer 15 and the base layer 20, and a portion of the perimetric edges 25, 30 are coupled by any means described herein to form the device 10. In another aspect of the present invention, the device 10 may be formed from the active layer 15 without a base layer 20 and without seams 35 if the active layer 15 is formed in a tube-like or a balloon-like form.

In an alternative aspect of the present invention, an additional mitting layer (not shown) of material may be added and attached to a portion of the perimetric edges 25, 30 while leaving at least one end open to form a mitt to be worn by the user. The mitt may be sized for a human hand, or may be sized for one or more human fingers, including taking the form of a finger glove.

The cleaning device 10 further includes a fluid-containing pouch 50. Three examples of suitable pouches are described in co-pending U.S. Patent Application Serial No. 11/303,061, filed on December 13, 2005 and titled "Device with Internal Pull Tab Activation," incorporated herein by reference.

In general, the pouch 50 may include a top layer 55 having an outer surface 60, and a bottom layer 65 attached to the top layer 55. The top and bottom layers 55, 65 are attached such that they form and enclose a cavity 70. The top and

bottom layers 55, 65 may be attached by thermal bonding, although any suitable attachment method may be used. The cavity 70 may be sealed such that it contains a fluid. The pouch 50 may be rectangular, square, circular, oblong, or any other suitable size or shape. In another aspect of the present invention, the
5 pouch 50 may be formed from the top layer 55 without a bottom layer 65 if the top layer 55 is formed in a tube-like or a balloon-like form.

The pouch 50 includes an opening 75 allowing fluid communication between the cavity 70 and the outer surface 60, although the opening 75 is typically initially sealed. The pouch 50 also includes a pull tab 96 that is removably
10 attached to the outer surface 60 of the pouch 50. The pull tab 96 is affixed to the outer surface 60 such that the pull tab 96 blocks and thereby seals the opening 75. The pull tab 96 may be made from 2 mil polyethylene film available from Bemis Company, Inc., although any suitable material may be used. The pull tab 96 may be affixed to the outer surface 60 using an adhesive such as a pressure-sensitive
15 acrylic adhesive or a frangible sealant poly available from Bemis Company, Inc.

The pull tab 96 may also include an extension extending from the pull tab 96. The extension from the pull tab 96 may be formed from the same material as the pull tab 96, or the extension may be formed separately and then affixed to the pull tab 96. The pull tab 96 and the extension may be together or separately
20 considered to be a pull tab. Pulling on the pull tab 96 causes the pull tab 96 to be removed from its position sealing the opening 75. In one aspect of the present invention, the pull tab 96 is folded back across itself. In this position, pulling the pull tab 96 in a direction generally tangential to the outer surface 60 causes the pull tab 96 to pull from the outer surface 60. The pull tab 96 is thus peeled away
25 from the pouch 50, thereby unsealing the opening 75. In one aspect of the present invention, and to ensure that the pull tab 96 remains in a position overlying the pouch 50 and itself, the pull tab 96 may be removably attached to the pouch 50 and/or itself using adhesive or any other suitable attachment method. To be clear, the pull tab 96 and the extension may be two regions of a single piece of material.

30 For any of the pouch configurations described herein, the pouch 50 is positioned within the interior space 40 of the device 10. The pouch cavity 70 may be sealed prior to being filled or partially filled with one or more fluids. The pouch

50 may be any size that fits within the interior space 40, with the size selected based on the fluid to be housed and the intended use of the device 10.

The pouch 50 may be sized to provide a level of over saturation that permits the fluid to soak through the wipe layer 15, permitting it to be absorbed by the intended surface. An example of this would be a stain removal cloth for carpet cleaning where it is desired to soak the stain.

The pouch 50 may be constructed from a flexible, heat sealable material such as 2 mil water dispersible polyethylene film available from Bemis Company, Inc. In other aspects of the present invention, the pouch 50 may be constructed from polyethylene, polypropylene, or other suitable thermoplastics. The material from which the pouch 50 is constructed should have no negative impact on or reaction with the fluid to be contained in the pouch 50. The materials used in the construction of the pouch 50 and the fill level of the fluid within the pouch 50 create a structure that is durable and flexible, and one that is not easily burst open during normal handling.

The pouch 50 may also be constructed from a material that exhibits better dispersibility characteristics, as well as being flushable. In one exemplary aspect of the present invention, the pouch 50 is constructed from a thin film of PLA, co-extruded with PVA, and a tissue layer. In this example, the PLA is a thin plastic film layer that provides some integrity to the pouch 50 as it is in contact with the formulation, allowing the pouch 50 to contain the ingredients and to refrain from breaking down upon contact with a wet formulation. The PVA is used as a dissolvable membrane that allows other layers to shed themselves from each other. Other types of film layers that can be used for dissolvability include ethylene oxide, PVA, PLA, hydroxyethylcellulose, methylethylcellulose, ethylene vinyl alcohol (EVA), and combinations of these.

The pouch 50 may also be constructed from the following. A coextruded bilayer film coated onto or otherwise bonded to a stabilizing, inextensible, but highly dispersible layer of, for example, tissue, has been developed in accordance with the invention to manage the balance of in-use integrity (strength and barrier) and flushability (wet flexibility and dispersibility). The base layer in the film may be a water-soluble PVA blend adhered to the tissue layer, with the tissue forming one exposed layer of the liner, while the second, exposed layer may be thin, low

strength, fluid-impervious, preferably water insoluble and biodegradable layer, which lines the inside of the product in, for example, a container embodiment. The PVA/tissue layers provide strength prior to disposal, so the product and contents can be carried to the toilet or other aqueous disposal area. In the toilet, the PVA and tissue dissolve or disperse, leaving only the very thin barrier layer and the body or other type of waste to move down the toilet. The thin barrier layer must have enough impermeability to contain substances when supported by the dry PVA/tissue layers; after clearing the toilet, the thin layer desirably will break up to avoid clogging in the pipes. The biodegradable nature of the barrier layer ensures a safe treatment and breakdown of the barrier remnants when they reach the wastewater treatment plant or septic system. It is also desired for certain applications that the barrier layer be maintained thin so as to avoid imparting excessive wet tensile properties to the composite of, for example, no more than 2000 g of wet tensile peak load and in some applications, no more than 1000 g. Examples of barrier film materials in addition to PLA include copolyesters such as Eastar Bio GP products from Eastman, polycaprolactone such as Tone P767 from Union Carbide Corporation, Danbury, CT, a polybutylene succinate polymer or a polybutylene succinate-co-adipate polymer or a mixture of such polymers, polypropylene oxide, cold-water insoluble PVA, PVA copolymers, gelatinized starch, nylon copolymers, acrylic acid copolymers, other copolymers of and blends of any of the foregoing. For specific examples, reference is directed to WO 96/20831 to Larson et al., incorporated herein in its entirety by reference. Desirable applications will include a barrier layer thickness of up to 5 microns and, in many cases, up to only about 2 microns.

Various polymers can be used for the thin barrier layer component which, advantageously, is formed by coextrusion with the water sensitive, for example PVA, layer. As previously mentioned, PLA is ideally suited as a barrier layer, but other polymers may be used, such as polyolefins and the others previously identified. PLA and other biodegradable resins are preferred for environmental reasons.

The water responsive (water sensitive) layer of the present invention includes compositions of selectively water-responsive polymer blends. These water-responsive polymer blends may be constructed from water-soluble and

hydrolytically-degradable polymers including polyethylene oxide (PEO) and PVA. Cold-water soluble PVA of partially hydrolyzed polyvinyl acetate is desired for the compositions of the present invention and typically the hydrolysis level is between approximately 70 percent and 85 percent. The term "hydrolysis level" as used
5 herein, is defined as the percentage of vinyl acetate units in polyvinyl acetate which are hydrolyzed into vinyl alcohol units in the polyvinyl alcohol. Depending upon the purpose and use of an article, compositions comprising different components of variable water sensitivity may be desired. Controlling water-responsiveness is necessary for different components in certain products due to
10 the location of use in relation to solutions. The thickness of the water responsive layer will depend on the desired use and will frequently be in the range of from about 10 microns to about 50 microns and, for some applications, in the range of from about 15 microns to about 45 microns.

In some aspects, the pouch material may have flushability issues.
15 Commonly used polyethylene films are not ideal for a flushable product because, while they will disperse or detach from the product, the film itself does not disperse and tends to float in water. Polyethylene film can pass entirely through modern treatment facilities intact and be in recognizable form in the treatment plant effluent. This issue may be avoided by use of a dispersible polymer for the pouch
20 50 of the present invention that is a blend of PEO and ethylene-co-acrylic acid (EAA) in a weight ratio of from about 95/5 to about 20/80, particularly about 80/20. This polymer blend has a density greater than that of water and so will sink, and is also dispersible in water. This polymer blend sometimes includes a fragrance capable of surviving melt extrusion. This blend may be extruded into a film using
25 either the cast chill roll or blown bubble processes, which are known in the art, at a thickness range of from 10 to 100 microns. A more particularly suitable thickness is from about 20 to 30 microns. Yet another suitable dispersible but not triggerable polymer is a PVA such as Ecomaty AX2000 or AX300G supplied by Nippon Gohsei, Higashi Umeda Bldg. 9-6, Nozai-cho, Kita-ku, Osaka 530, Japan.

30 The polymer blend for the pouch material may be co-extruded with another water impervious film layer in the range of about 2 to 4 microns thick. A suitable polymer is ethylene acrylic acid (EAA) like those available from The Dow Chemical Company of Midland, MI as Primacor 1430. Another suitable polymer is

polycaprolactone like that available from Union Carbide of Danbury, CT as Tone P787. The water-impervious layer may also be a trigger polymer such as National Starch's 70-4395 and 8824-71-1. As an alternative to co-extrusion, a water-impervious layer on the water soluble portion can be added by a coating process.

5 For example, PEO film can be slot coated with a 90/10 blend by weight of RT2730 poly alpha olefin from Rexene Products, Dallas, TX and Vybar 253 polymer from Petrolite Polymers, Tulsa, OK.

10 In one aspect of the present invention the pouch 50 contains multiple layers of film or nonwoven materials. One layer may serve as a barrier layer to provide integrity to the pouch 50 and prevent the structure of the device from dissolving until it is completely immersed in water.

15 In one aspect of the present invention, the pouch 50 may also include one or more bonding points 98 at which the top layer 55 is affixed to the bottom layer 65. The bonding points 98 may be formed by any method described above for affixing the top layer 55 to the bottom layer 65 to form the pouch 50. The bonding points 98 act to inhibit the top layer 55 from moving relative to the bottom layer 65 when force is applied to the pull tab 96. In one aspect of the present invention, the bonding points 98 may be positioned within the cavity 70 and spaced apart from the edges of the pouch 50. Although described as points, in other aspects of the present invention the bonding points 98 may be lines, geometric shapes, or any other suitable shapes or sizes.

20 In one aspect of the present invention, the pull tab 96 may extend to the perimetric edges 25, 30 of the wipe and base layers 15, 20. The pull tab 96 may be incorporated into the seam 35 or otherwise attached to one or more of the wipe layer 15, base layer 20, and barrier layer. This arrangement allows the pull tab 96 to be manipulated by a user without actually touching the pull tab 96 when the pouch 50 is positioned within the interior space 40. Pulling on the perimetric edges 25, 30 pulls on the pull tab 96 as well. The pull tab 96 may thereby remain within the interior space 40.

30 In another aspect of the present invention, the pull tab 96 may extend beyond the perimetric edges 25, 30 of the wipe and base layers 15, 20. The pull tab 96 may pass through a gap in the seam 35. This arrangement allows the pull tab 96 to be manipulated by a user by pulling the pull tab 96 when the pouch 50 is

positioned within the interior space 40. In alternative aspects of the present invention, the pull tab 96 may thereby remain attached within the interior space 40 or may be pulled free of the internal space 40. The pouch 50 may also be incorporated into the seam 35 or otherwise attached to one or two of the wipe layer 15, base layer 20, and barrier layer.

The pouch 50 may be attached to one or both of the wipe and base layers 15, 20 by adhering all or a portion of the adjacent surfaces to one another with any pattern of adhesive. The adhesive may be a water insoluble adhesive, or an adhesive that becomes soluble after time, for example, after about 1 minute. Alternatively, portions of one or both of the wipe and base layers 15, 20 may be fused or bonded to the adjacent surface of the pouch 50 material and/or back sheet by conventional bonding methods. The pouch 50 may also be incorporated into the seam 35 or otherwise attached to one or two of the wipe layer 15, base layer 20, and barrier layer. In one aspect of the present invention, the pouch 50 is bonded to one of the wipe layer 15, the base layer 20, or the barrier layer. In another aspect of the present invention, the airlaid material of the wipe and/or base layers 15, 20 and the pouch 50 may be held together by ultrasonic bonding and the use of a flexible absorbent binder in combination with a latex or with 10 percent glycol.

In conjunction with any of the pouch configurations described herein, and in another aspect of the present invention that is not shown, the device 10 may include a line of stitching, glue, or other suitable means to define a pocket within the interior space 40 to hold a pouch 50 in place.

In another aspect of the invention that is not shown, a distribution layer may be interposed between the pouch and the wipe layer 15 to ensure fluid is distributed across the wipe layer 15. The distribution layer may be, for example, a surge material that wicks fluid to a substantial portion of the wipe layer 15.

In yet another aspect of the present invention, distribution of fluid into the wipe or base layers 15, 20 may be controlled by using materials with different wicking and other properties that will absorb and distribute the fluid in different patterns, rates, and manners.

The fluid contained in the cavity of the pouch may be any fluid suitable for the intended use of the device 10, including cleansing fluids for human/animal use

and cleaning fluids for cleaning surfaces. The fluid may be any paste, gel, powder, oil, liquid, or any other appropriate medium. Example cleansing fluids include surfactants such as water-soluble polymers, polysorbates, glycerins, glycol-based surfactants, and/or silicone-based surfactants. The fluid may include other materials, such as water, salts, vinegars, humectants, scouring powders, thickening agents, and fragrances. A cleansing fluid may also include a moisturizer that helps to maintain a normal skin hydration level. A cleansing fluid may also include preservatives and other ingredients that do not disrupt the skin (e.g., sorbic acid, citric acid, methyl paraben, and natural preservatives such as grapefruit extract). The fluid may include other materials that may be applied to an area of the body. Example materials include lubricants, deodorants, and other inactive or active ingredients (e.g., spermicidal agent or medication). In one aspect of the present invention, the fluid is a cleansing fluid that is primarily a water-based solution (greater than or equal to 90 percent water content) with a surfactant, preservatives, pH neutralizers, and a thickening agent.

The fluid may be a cleaning solution such as FOUR PAWS Super Strength Stain and Odor Remover, which includes water, natural enzymes, and mild detergent (from Four Paws Products, Ltd., Hauppauge, NY), or NATURE'S MIRACLE Stain & Odor Remover, which includes water, natural enzymes, isopropyl alcohol, and natural citrus scent (from Pets 'N People, Inc., Rolling Hills Estates, CA), or RESOLVE Carpet Spot & Stain Carpet Cleaner (from Reckitt Benckiser, Wayne, NJ). The fluid may be a pet shampoo. The fluid may be a stain cleaner and stain guard such as SCOTCHGARD Oxy Carpet Cleaner with Stain Protector that includes water, 2-butoxyethanol, hydrogen peroxide, and surfactants (from 3M Corporation, St. Paul, MN). In the case of using the cleaning device 10 to clean a fabric surface, the fluid may include a pet repellent such as SIMPLE SOLUTION Indoor/Outdoor Repellent for Dogs and Cats, which has as an active ingredient methyl nonyl ketone (from The Bramton Company, Dallas, TX).

The fluid may be an antimicrobial. Examples of suitable antimicrobials include quaternary ammonium compounds such as 3-trimethoxysilylpropyldimethyloctadecyl ammonium chloride (AEGIS); poly cationic chemicals such as biguanides (poly (hexamethylene) biguanide hydrochloride (PHMB) Arch Chemical), 2, 4, 4'-Trichloro-2' - hydroxyl-dipenylether (Tinosan,

Ciba); diphenyl ether (bis-phenyl) derivatives known as either 2, 4, 4'-trichloro-2'-hydroxy dipenyl ether or 5-chloro-2-(2, 4-dichlorophenoxy) phenol; triclosan; silver; and copper. The fluid may be an allergen sequestrant that may be a charged or mixed charged particle or nanoparticle. Most allergy proteins are

5 glycoproteins (proteins that contain covalently-bound oligosaccharides), so a negative charge may be better than predominance of positive charges on the particles, although mixed charges may be preferred. Clays or modified clays work in this respect. Examples of suitable allergen sequestrants include plant lectins with an affinity for N-acetylgalactosamine such as jacalin, peanut, and soybean,

10 where the lectins both bind allergens and are bound to the web, thus removing allergens from a surface. The fluid may also include a fragrance. The fluid may also include a pheromone to either attract or repel an animal. The fluid may also be shoe polish, a carpet cleaning solution, a stain removal fluid, kitchen floor and counter top cleaners, etc.

15 In another aspect of the present invention, the device 10 includes pull indicators 100 associated with each of the opposed ends 42. The pull indicators 100 indicate to a user where the device 10 should be pulled to activate the device 10. In some aspects of the present invention, the pull indicators 100 may be arrows, instructions, or other indicia printed on or otherwise associated with (such

20 as with a tag) the device 10, such as on or near the opposed ends 42. In other aspects of the present invention, the pull indicators 100 may be raised, indented, embossed, or otherwise highlighted indicia associated with the device 10, such as on or near the opposed ends 42. In still other aspects of the present invention, the pull indicators 100 may be tabs, loops, extensions, or any other suitable structure

25 coupled to the opposed ends 42. The pull indicators 100 may also be a combination of two or more of these examples.

In use in one aspect of the present invention, a user grasps each opposed end 42 or each pull indicator 100, as appropriate, and pulls the opposed ends 42 away from each other, causing the pull tab 96 to unseal the opening 75. In use in

30 another aspect of the present invention, a user grasps one end 42 or one pull indicator 100, as appropriate, and the pull tab 96, and pulls them away from each other, causing the pull tab 96 to unseal the opening 75.

Embodiments of the invention have been described with reference to various specific and illustrative aspects and techniques. However, it should be understood that many variations and modifications may be made while remaining within the spirit and scope.

- 5 Accordingly, this is intended to embrace all such alternatives, modifications and variations that fall within the spirit and scope of the appended claims.

We claim:

1. A device comprising:
a water-dispersible base layer;
5 a water-dispersible wipe layer attached to the base layer at a seam and defining an interior space between the wipe and base layers, the interior space having an internal surface; and
a pouch positioned within the interior space, the pouch having
a top layer,
10 a bottom layer attached to the top layer to form a cavity therebetween,
an opening in one of the top and bottom layers, and
a pull tab attached to the pouch.
- 15 2. The device of claim 1, wherein the pouch is configured such that the opening is uncovered when the pull tab is pulled.
3. The device of claim 1, further comprising a barrier layer interposed
20 between the pouch and the base layer.
4. The device of claim 3, wherein the device is a finger glove.
5. The device of claim 1, wherein the device is a pad.
- 25 6. The device of claim 1, wherein the device is a mitt.
7. The device of claim 1, further comprising a pull indicator.
8. The device of claim 1, wherein the pouch is attached at the seam.
- 30 9. The device of claim 1, wherein the pull tab is attached at the seam.
10. The device of claim 1, wherein the wipe layer is stretchable.

11. The device of claim 10, wherein the wipe layer is elastically stretchable.

12. The device of claim 1, wherein the base layer is stretchable.

13. The device of claim 12, wherein the base layer is elastically stretchable.

14. The device of claim 1, wherein the opening is a slit.

15. The device of claim 1, wherein the opening includes a frangible portion.

16. The device of claim 1, further comprising a bonding point affixing the top layer to the bottom layer.

17. The device of claim 1, wherein the wipe layer and the base layer are two portions of the same piece of material.

18. The device of claim 1, wherein the pouch is dispersible when immersed in water.

19. A device comprising:
a water-dispersible base layer;
a water-dispersible wipe layer attached to the base layer to form an internal space therebetween, and;
a means for containing a fluid positioned within the internal space, and
a means for unsealing the fluid-containing means, wherein the unsealing means is activated by stretching one of the wipe and base layers.

20. A method for using a device, the method comprising:
producing a device including
a water-dispersible base layer,
a water-dispersible wipe layer attached to the base layer at a seam
5 and defining an interior space between the wipe and base layers, the interior
space having an internal surface, and
a pouch positioned within the interior space, the pouch having a pull
tab attached to the pouch; and
activating the device by pulling the pull tab to open the pouch.
- 10
21. The method of claim 20, wherein the device is disposed of by placing
in a toilet and flushing.
22. A method for using a device, the method comprising:
15 producing a device including a water-dispersible base layer and a water-
dispersible wipe layer attached to the base layer at a seam and defining an interior
space between the wipe and base layers, the interior space having an internal
surface; and
activating the device by stretching the device.
- 20
23. The method of claim 22, further comprising a pouch positioned within
the interior space and attached to one of the seam and the internal surface, the
pouch having a pull tab coupled to the pouch and to one of the seam and the
internal surface.
- 25
24. The method of claim 22, wherein stretching the device opens the
pouch.

25. A device comprising:
a water-dispersible base layer;
a water-dispersible wipe layer attached to the base layer at a seam and
defining an interior space between the wipe and base layers, the interior space
5 having an internal surface; and
a pouch positioned within the interior space and attached to one of the
seam and the internal surface, the pouch having
a top layer,
a bottom layer attached to the top layer to form a cavity
10 therebetween,
an opening in one of the top and bottom layers, and
a pull tab attached to the pouch.
26. A device comprising:
15 a wipe layer formed to define an interior space, the interior space having an
internal surface; and
a pouch positioned within the interior space and attached to the internal
surface, the pouch having
an outer surface,
20 an opening in the outer surface, and
a pull tab coupled to the pouch.
27. The device of claim 26, wherein the pouch is configured such that the
opening is uncovered when the pull tab is pulled.
25
28. The device of claim 26, wherein the pull tab is coupled to the internal
surface.
29. The device of claim 26, wherein the pouch is configured such that a
30 tear is created at a specified location when the pull tab is pulled.

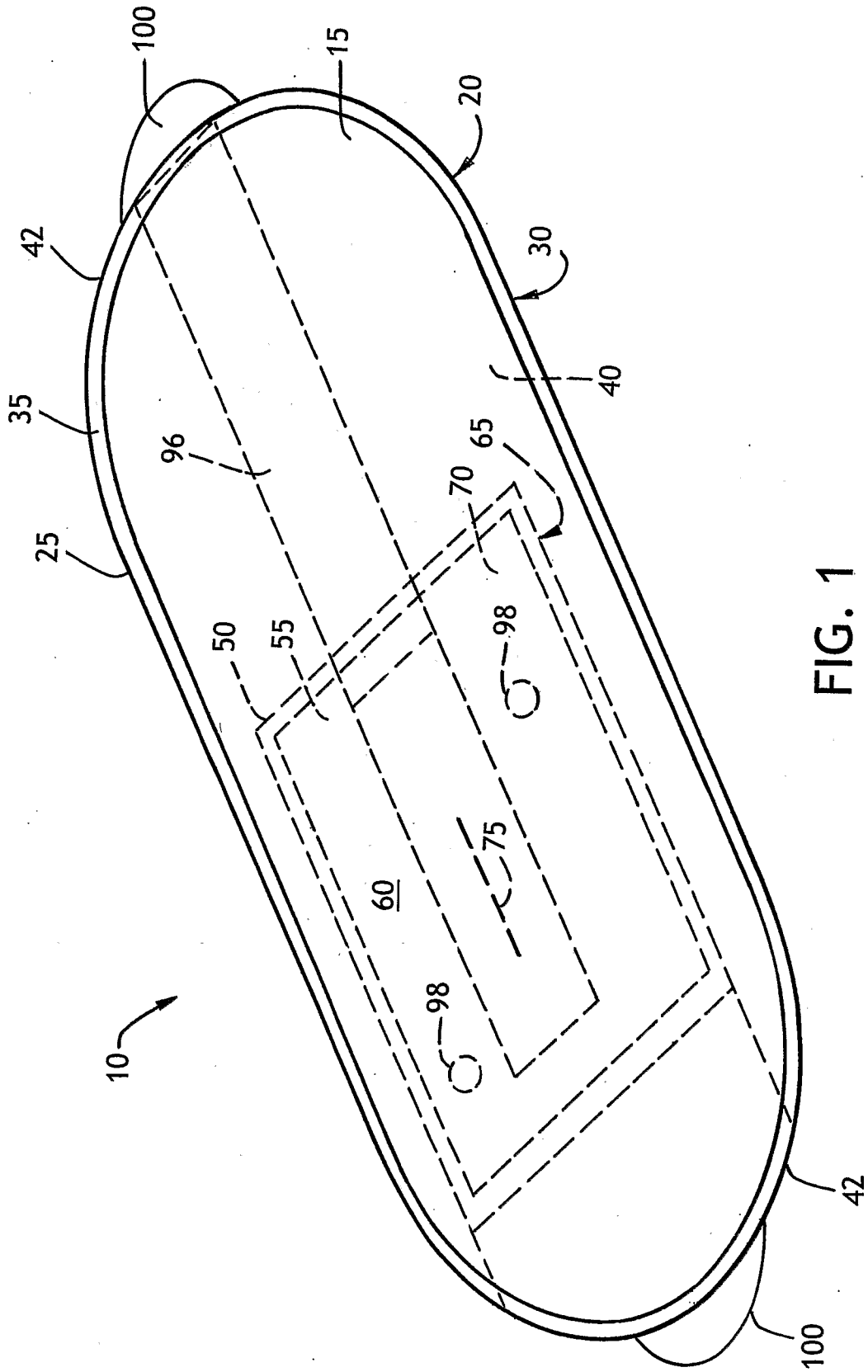

FIG. 1