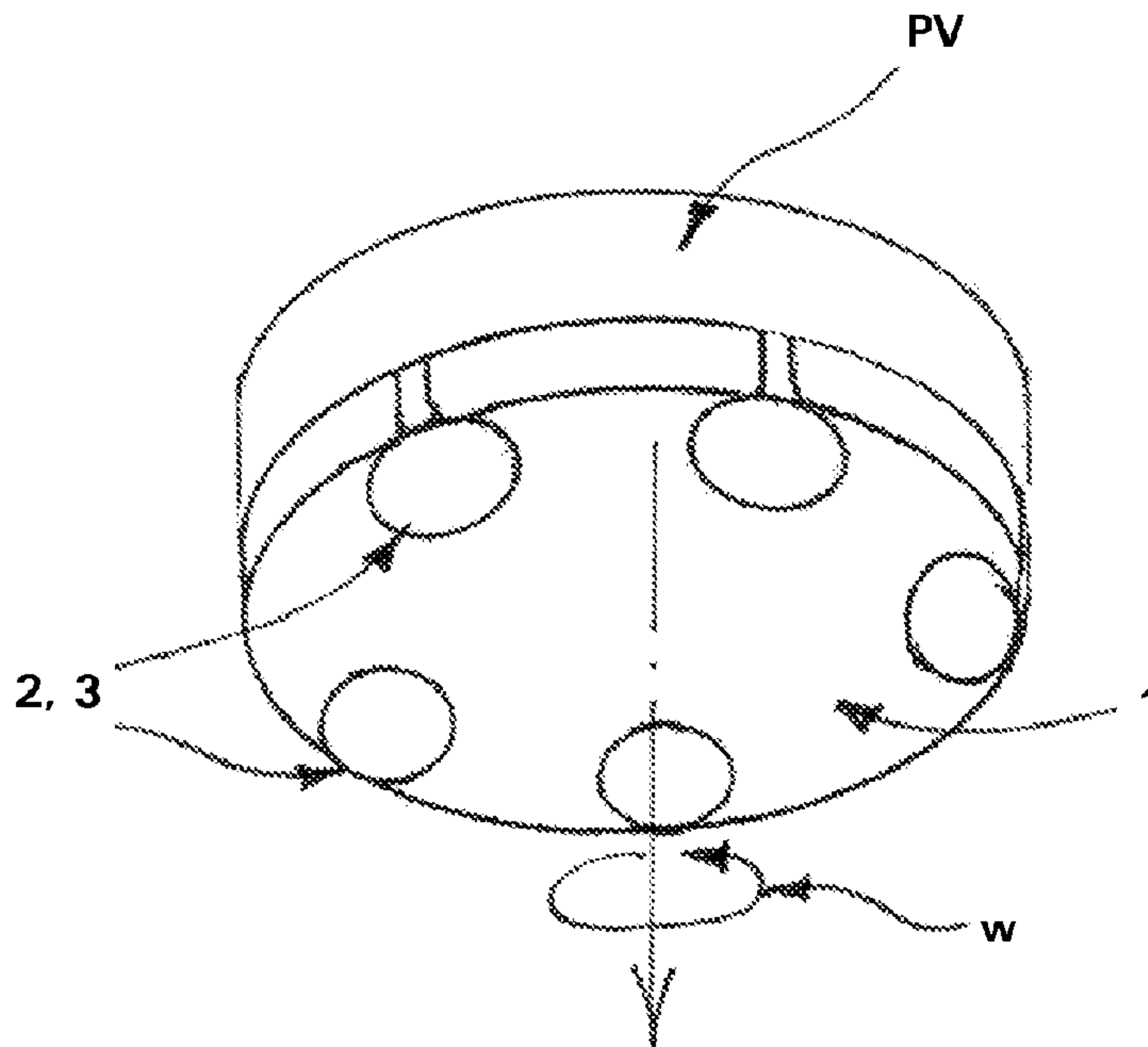




(86) **Date de dépôt PCT/PCT Filing Date:** 2012/06/01  
 (87) **Date publication PCT/PCT Publication Date:** 2012/12/27  
 (85) **Entrée phase nationale/National Entry:** 2013/11/14  
 (86) **N° demande PCT/PCT Application No.:** FI 2012/050544  
 (87) **N° publication PCT/PCT Publication No.:** 2012/175790  
 (30) **Priorité/Priority:** 2011/06/23 (FI20115647)

(51) **Cl.Int./Int.Cl. B24D 13/14** (2006.01),  
**A47L 11/164** (2006.01), **B24B 7/14** (2006.01),  
**B24B 7/18** (2006.01)  
 (71) **Demandeur/Applicant:**  
 AHONEN, MIKA, FI  
 (72) **Inventeur/Inventor:**  
 AHONEN, MIKA, FI  
 (74) **Agent:** BORDEN LADNER GERVAIS LLP

(54) **Titre : AGENCEMENT POUR LE PONCAGE DE SOL**  
 (54) **Title: ARRANGEMENT FOR FLOOR GRINDING**



**FIG. 6b**

(57) **Abrégé/Abstract:**

The invention relates to an arrangement for floor grinding, which is meant particularly for grinding of a floor with a floor conditioning device, such as a combination machine, floor conditioning machine or like. The arrangement comprises a tool instrument (1) to be



**(57) Abrégé(suite)/Abstract(continued):**

used in the floor conditioning device by rotating (w) the same, the instrument being an essentially porous washing, polishing, waxing disk or like for carrying out basic functions of the floor conditioning device, and a grinding instrument (2), such as a diamond disk, to be coupled removably in connection with the tool instrument (1), or several of the kind, being essentially alike and being placed symmetrically in connection with the tool instrument (1). The arrangement comprises fastening means (3) in order to couple the grinding instrument (2) with the tool instrument (1) on the one hand by a fastening frame supported on its front surface and on the other hand by an auxiliary frame supported on its back surface.

(12) INTERNATIONAL APPLICATION PUBLISHED UNDER THE PATENT COOPERATION TREATY (PCT)

(19) World Intellectual Property  
Organization  
International Bureau(43) International Publication Date  
27 December 2012 (27.12.2012)

WIPO | PCT

(10) International Publication Number  
WO 2012/175790 A1

## (51) International Patent Classification:

B24D 13/14 (2006.01) B24B 7/18 (2006.01)  
A47L 11/164 (2006.01) B24B 7/14 (2006.01)

## (21) International Application Number:

PCT/FI2012/050544

## (22) International Filing Date:

1 June 2012 (01.06.2012)

## (25) Filing Language:

Finnish

## (26) Publication Language:

English

## (30) Priority Data:

20115647 23 June 2011 (23.06.2011) FI

## (72) Inventor; and

(71) Applicant : AHONEN, Mika [FI/FI]; Jänispolku 6, FI-39200 Kyröskoski (FI).

(74) Agent: KANGASMÄKI, Reijo; Finnish Patent Consulting FPC, PL 25, FI-33401 Tampere (FI).

(81) Designated States (unless otherwise indicated, for every kind of national protection available): AE, AG, AL, AM,

AO, AT, AU, AZ, BA, BB, BG, BH, BR, BW, BY, BZ, CA, CH, CL, CN, CO, CR, CU, CZ, DE, DK, DM, DO, DZ, EC, EE, EG, ES, FI, GB, GD, GE, GH, GM, GT, HN, HR, HU, ID, IL, IN, IS, JP, KE, KG, KM, KN, KP, KR, KZ, LA, LC, LK, LR, LS, LT, LU, LY, MA, MD, ME, MG, MK, MN, MW, MX, MY, MZ, NA, NG, NI, NO, NZ, OM, PE, PG, PH, PL, PT, QA, RO, RS, RU, RW, SC, SD, SE, SG, SK, SL, SM, ST, SV, SY, TH, TJ, TM, TN, TR, TT, TZ, UA, UG, US, UZ, VC, VN, ZA, ZM, ZW.

(84) Designated States (unless otherwise indicated, for every kind of regional protection available): ARIPO (BW, GH, GM, KE, LR, LS, MW, MZ, NA, RW, SD, SL, SZ, TZ, UG, ZM, ZW), Eurasian (AM, AZ, BY, KG, KZ, RU, TJ, TM), European (AL, AT, BE, BG, CH, CY, CZ, DE, DK, EE, ES, FI, FR, GB, GR, HR, HU, IE, IS, IT, LT, LU, LV, MC, MK, MT, NL, NO, PL, PT, RO, RS, SE, SI, SK, SM, TR), OAPI (BF, BJ, CF, CG, CI, CM, GA, GN, GQ, GW, ML, MR, NE, SN, TD, TG).

## Published:

— with international search report (Art. 21(3))

## (54) Title: ARRANGEMENT FOR FLOOR GRINDING

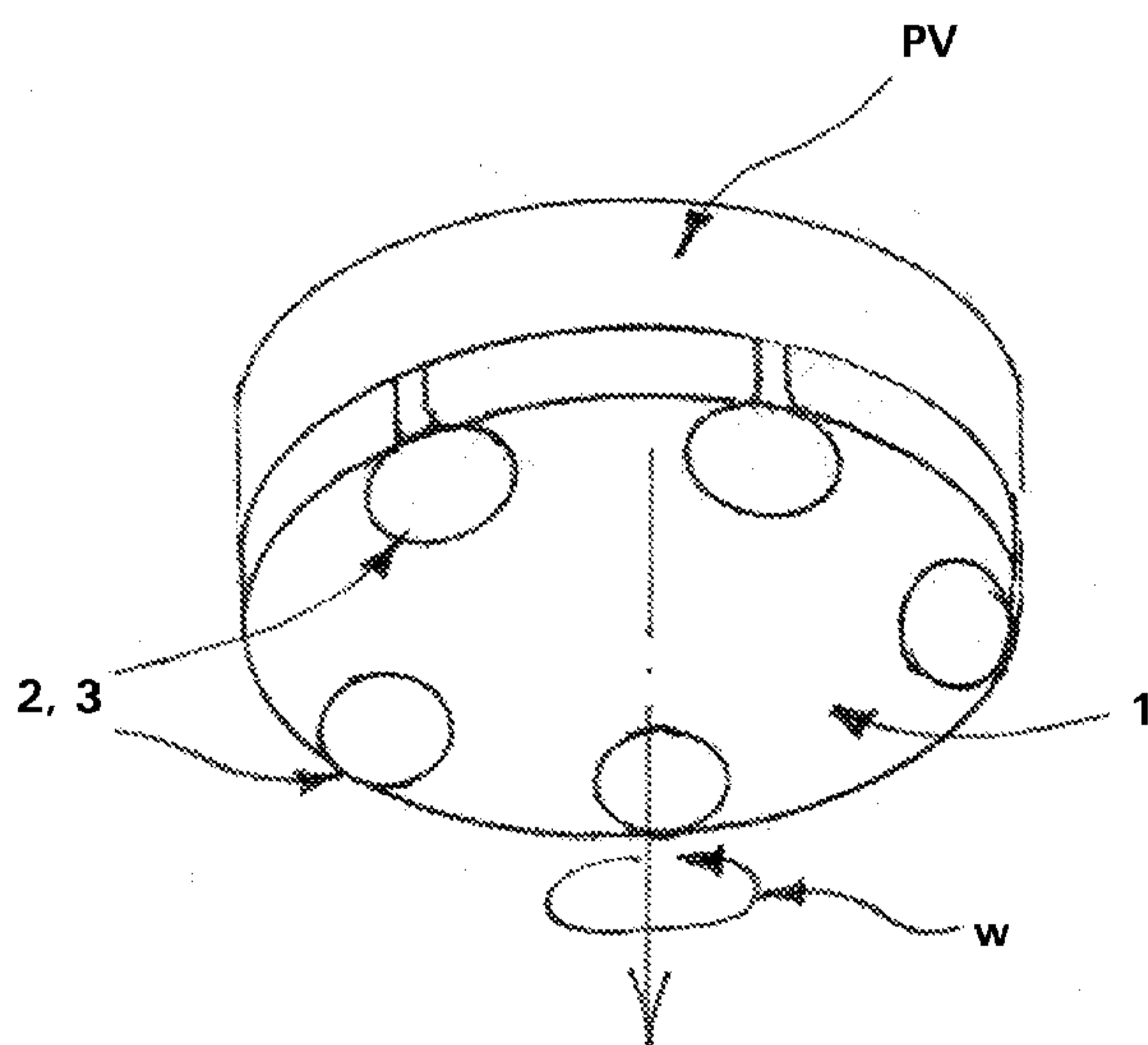


FIG. 6b

(57) Abstract: The invention relates to an arrangement for floor grinding, which is meant particularly for grinding of a floor with a floor conditioning device, such as a combination machine, floor conditioning machine or like. The arrangement comprises a tool instrument (1) to be used in the floor conditioning device by rotating (w) the same, the instrument being an essentially porous washing, polishing, waxing disk or like for carrying out basic functions of the floor conditioning device, and a grinding instrument (2), such as a diamond disk, to be coupled removably in connection with the tool instrument (1), or several of the kind, being essentially alike and being placed symmetrically in connection with the tool instrument (1). The arrangement comprises fastening means (3) in order to couple the grinding instrument (2) with the tool instrument (1) on the one hand by a fastening frame supported on its front surface and on the other hand by an auxiliary frame supported on its back surface.

### Arrangement for floor grinding

5 The invention relates to an arrangement for floor grinding, which is particularly meant for grinding of a floor with a floor conditioning device, such as a combination machine, floor conditioning machine or like. The arrangement comprises a tool instrument to be used in the floor conditioning device by rotating the same, the instrument being an essentially porous washing, polishing, waxing disk or like for carrying out basic functions of the floor conditioning device, and a grinding instrument, such as a diamond disk, to be coupled removably in connection with the tool instrument, or preferably several of the kind, being essentially alike and being placed symmetrically in connection with the tool instrument.

10 At present, in the above mentioned context, various floor conditioning devices are being used for conditioning and maintenance of most heterogeneous floor surfaces. Combination machines in this context refer to usually top-driven or pushable conditioning machines with which e.g. washing of the floor with water is possible to be executed in a way that also water can be sucked from the floor with the machine. There may be several rotating disks in this type of a combination machine. On the other hand, e.g. pushable floor conditioning machines that use one rotating disk are also being used.

20 Furthermore, for more efficient floor grinding e.g. diamond disks that are coupled removably e.g. to the bottom surface of an ordinary washing, polishing or waxing disk used for floor conditioning are known to be exploited in connection with the above mentioned device types. In this way, thanks to the diamond disks attached to the disk, the same also may be used for

more efficient floor grinding in addition to basic washing and conditioning procedures. For their part, in use, there are usually structurally two types of diamond disks, ie. metal bond diamond disks and on the other hand plastic bond diamond disks. Furthermore, at present in this context the diamond disks are known to be connected at simplest by e.g. sticker tape attachment to the bottom surface of a porous tool instrument, like e.g. a washing disk, in addition to which today's novelty are diamond disks attached to the washing disk's bottom surface with glue that, however, do not anymore enable the washing disk to be used in its original purpose after removal of a diamond disk glued thereto.

The rotation speed of e.g. so called slow rotation floor conditioning machines varies typically between 150-500 rpm, whereas in so called fast rotation floor conditioning machines the rotation speed may even be above 900 rpm. Therefore coupling the diamond disks only to the bottom surface of the washing disk always imposes a risk, as the diamond disk may dart at a high speed in case the washing disk is worn out, the sticker tape attachment is so to speak pilled or the glueing of the diamond disk fails, therefore imposing a work safety risk in addition to other possible damages caused.

It is an aim of the arrangement for floor grinding according to the present invention to achieve a decisive improvement in the problems described above and thus to raise essentially the level of prior art. In order to carry out this aim, the arrangement according to the invention is mainly characterized by that it comprises fastening means in order to couple the grinding instrument with the tool instrument on the one hand by a fastening frame supported on its front

surface and on the other hand by an auxiliary frame supported on its back surface.

5 As the most important advantages of the arrangement according to the invention are the simplicity and efficiency of the structures related thereto and use thereof, thanks to one or more grinding instruments, such as diamond disks, being couplable for use in a fast and reliable manner thanks to two-sided fastening  
10 thereof to the tool instrument without the risk of e.g. inadvertent detachment of a diamond disk during grinding. The fastening means according to the invention may advantageously be implemented e.g. as a compound structure entirety made of a elastic/flexible  
15 material reaching to the opposite sides of the tool instrument.

Therefore, thanks to the invention, a grinding instrument, e.g. a diamond disk, suitable for the  
20 purpose at any given time may be coupled to e.g. a washing disk in an easily attachable manner and removably without breaking of the washing disk in a way that the disk is as a further advantageous embodiment locked with the washing disk e.g. by anchoring means  
25 passing through the disk and/or by retaining means in the opposite attachment and auxiliary frames getting pressed onto the washing disk's outer and inner surfaces. With a coupling of the tool instrument and the grinding instrument/instruments implemented  
30 according to the arrangement of the invention, the floor conditioning procedures may be intensified decisively improving work safety at the same time.

Other advantageous embodiments of the arrangement  
35 according to the invention have been presented in the dependent claims related thereto.

In the following description, the invention is illustrated in detail with reference to the appended drawings, in which

5 in figures 1a-1c

are shown a bottom view, a cross-section view and an upper view of an advantageous arrangement according to the invention,

10 in figures 2a-2c

are shown views according to figure 1 of another alternative arrangement according to the invention,

15 in figures 3a-3c

are shown views according to figure 1 of a third alternative arrangement according to the invention,

20 in figures 4a-4c

are shown views according to figure 1 of a fourth alternative arrangement according to the invention,

25 in figures 5a-5c

are furthermore shown views according to figure 1 of a fifth alternative arrangement according to the invention, and furthermore

30 in figures 6a and 6b

is firstly shown coupling of a waxing disk equipped with grinding instruments, being coupled therewith by fastening means according to the invention, to a floor conditioning device's pull platform, and on the other hand there is shown usage of the above mentioned combination in floor grinding.

35

The invention relates to an arrangement for floor grinding, which is particularly meant for grinding of a floor with a floor conditioning device, such as a combination machine, floor conditioning machine or like. The arrangement comprises a tool instrument 1 to be used in the floor conditioning device by rotating w the same, the instrument being an essentially porous washing, polishing, waxing disk or like for carrying out basic functions of the floor conditioning device, and a grinding instrument 2, such as a diamond disk, to be coupled removably in connection with the tool instrument 1, or preferably several of the kind, being essentially alike and being placed symmetrically in connection with the tool instrument 1. The arrangement comprises fastening means 3 in order to couple the grinding instrument 2 with the tool instrument 1 on the one hand by a fastening frame 3a supported on its front surface 1a and on the other hand by an auxiliary frame 3b supported on its back surface 1b.

In figure 6a is shown an advantageous embodiment of the arrangement according to the invention, in which a waxing disk 1 equipped with grinding instruments 2, being coupled therewith by fastening means 3 according to the invention, is being coupled with e.g. an ordinary floor conditioning device's pull platform PV, the fastening surface K of which typically comprises hundreds of small spikes. When the waxing disk 1 is pushed against this fastening surface, the tool instrument 1 gets stuck on its place as the spikes on the fastening surface K penetrate the porous waxing disk. After this, the waxing disk equipped with e.g. diamond disks may therefore be used for floor grinding in a way depicted in figure 6b, the disk being rotated w by the floor conditioning device.

The simplest embodiments of the invention are shown in figures 1a-1c and 2a-2c, in which the fastening means

3 comprise an auxiliary frame 3b attached on the washing disk's back surface 1b, the auxiliary frame being directly couplable with the fastening frame 3a arranged in connection with the grinding instrument 2, such as a diamond disk, on the washing disk's front surface.

As an advantageous embodiment of the arrangement according to the invention with reference to the alternative embodiments shown in figures 3a-3c, 4a-4c and 5a-5c, the fastening means 3 belonging thereto comprise a fastening frame 3a that is separate to the grinding instrument 2 and supported on the tool instrument's front surface 1a and an auxiliary frame 3b supported on the tool instrument's back surface 1b.

Furthermore, as an advantageous embodiment particularly with reference to figures 1a-1c, 2a-2c and 3a-3c, the arrangement also comprises anchoring means 4 for coupling of the grinding instrument 2 and/or the fastening frame 3a removably with the auxiliary frame 3b. In this context it is advantageously also possible to use quick-release principle, such as a snap lock joint or the like.

Furthermore, as an advantageous embodiment particularly with reference to the alternatives shown in figures 1a-1c and 2a-2c, the auxiliary frame 3b of the fastening means 3 is carried out by a separate part.

Furthermore, as an advantageous embodiment particularly with reference to the alternative embodiments shown in figures 1a-1c, 2a-2c, 3a-3c, 4a-4c and 5a-5c, the fastening frame 3a of the fastening means 3 and the auxiliary frame 3b are arranged as a built-in entirety that extends on opposite sides of the tool instrument 1.

As a further advantageous embodiment, the anchoring means 4 comprise locking pins 4a provided with the grinding instrument, the fastening frame and/or the auxiliary frame 2, 3a, 3b in a built-in manner and going through the tool instrument 1, for getting locked with counterpart surfaces 4b existing in an opposite part 3b, 3a, 2.

As a further advantageous embodiment particularly with reference to the alternatives shown in figures 4a-4c and 5a-5c, the grinding instrument 2, the fastening frame 3a and/or the auxiliary frame 3b is/are provided with retaining means 5 that protrude inside the tool instrument 1 through its front and/or back surface 1a, 1b.

As a further advantageous embodiment particularly with reference to the alternatives shown in figures 3a-3c, 4a-4c and 5a-5c, the fastening frame 3a of the fastening means 3 is provided with means 6 for fastening of the grinding instrument 2 to the same chemically, such as by glueing, mechanically, such as by sticker gripping or snap lock jointing, melting, such as by welding, and/or in a corresponding manner.

Particularly in the advantageous embodiments shown in figures 3a-3c, 4a-4c and 5a-5c, the fastening means 3 are arranged as a built-in entirety extending on opposite sides of the tool instrument 1 and being manufactured from elastic/flexible material, wherein the fastening and the auxiliary frames 3a, 3b positioned against the front and back surfaces 1a, 1b of the tool instrument, are provided as a furthermore advantageous embodiment with e.g. retaining means 5 extending inside the tool instrument.

Furthermore, in the advantageous embodiment shown in figures 5a-5c, the fastening frame 3a of the fastening

means 3 is provided with an opening A at a corresponding point as the auxiliary frame 3b, when viewed in a direction of height h perpendicular to a plane defined by the tool instrument 1. In this manner  
5 minimizing of the amount of material needed for manufacturing the fastening means is enabled.

It is clear that the invention is not limited to the embodiments shown or described above, but it can be  
10 modified within the basic idea of the invention in very many ways, e.g. by combining the embodiments shown in the appended figures together etc. Also the types of implementations that are mentioned above may be executed structurally in different ways regarding  
15 structure or appearance thereof etc. than what is described above. The part entireties of the arrangement according to the invention may in addition be manufactured from a variety of materials, exploiting a variety of manufacturing techniques using plastic,  
20 ceramic, composite, carbon fibre materials or the like, without forgetting metal structures, such as light alloy implementations.

Claims:

1. Arrangement for floor grinding, which is particularly meant for grinding of a floor with a floor conditioning device, such as a combination machine, floor conditioning machine or like, whereby the arrangement comprises a tool instrument (1) to be used in the floor conditioning device by rotating (w) the same, the instrument being an essentially porous washing, polishing, waxing disk or like for carrying out basic functions of the floor conditioning device, and a grinding instrument (2), such as a diamond disk, to be coupled removably in connection with the tool instrument (1), or preferably several of the kind, being essentially alike and being placed symmetrically in connection with the tool instrument (1), **characterized** in that the arrangement comprises fastening means (3) in order to couple the grinding instrument (2) with the tool instrument (1) on the one hand by a fastening frame (3a) supported on its front surface (1a) and on the other hand by an auxiliary frame (3b) supported on its back surface (1b).

2. Arrangement according to claim 1, **characterized** in that, it comprises anchoring means (4) for coupling of the grinding instrument (2) and/or the fastening frame (3a) removably with the auxiliary frame (3b).

3. Arrangement according to claim 2, **characterized** in that, the anchoring means (4) are arranged to be locked on quick-release principle, such as by a snap lock joint, or correspondingly.

4. Arrangement according to any of the preceding claims 1-3, **characterized** in that auxiliary frame (3b) of the fastening means (3) is carried out by a separate part.

5. Arrangement according to any of the preceding claims 1-3, **characterized** in that, the fastening frame (3a) of the fastening means (3) and the auxiliary frame (3b) are arranged as a built-in entirety that extends on opposite sides of the tool instrument (1).

6. Arrangement according to any of the preceding claims 2-5, **characterized** in that, the anchoring means (4) comprise locking means (4a) provided with the grinding instrument, the fastening frame and/or the auxiliary frame (2, 3a, 3b) in a built-in manner and going through the tool instrument (1), for getting locked with counterpart means (4b) existing in an opposite part (3b, 3a, 2).

7. Arrangement according to any of the preceding claims 1-6, **characterized** in that, the grinding instrument (2), the fastening frame (3a) and/or the auxiliary frame (3b) is/are provided with retaining means (5) that protrude inside the tool instrument (1) through its front and/or back surface (1a, 1b).

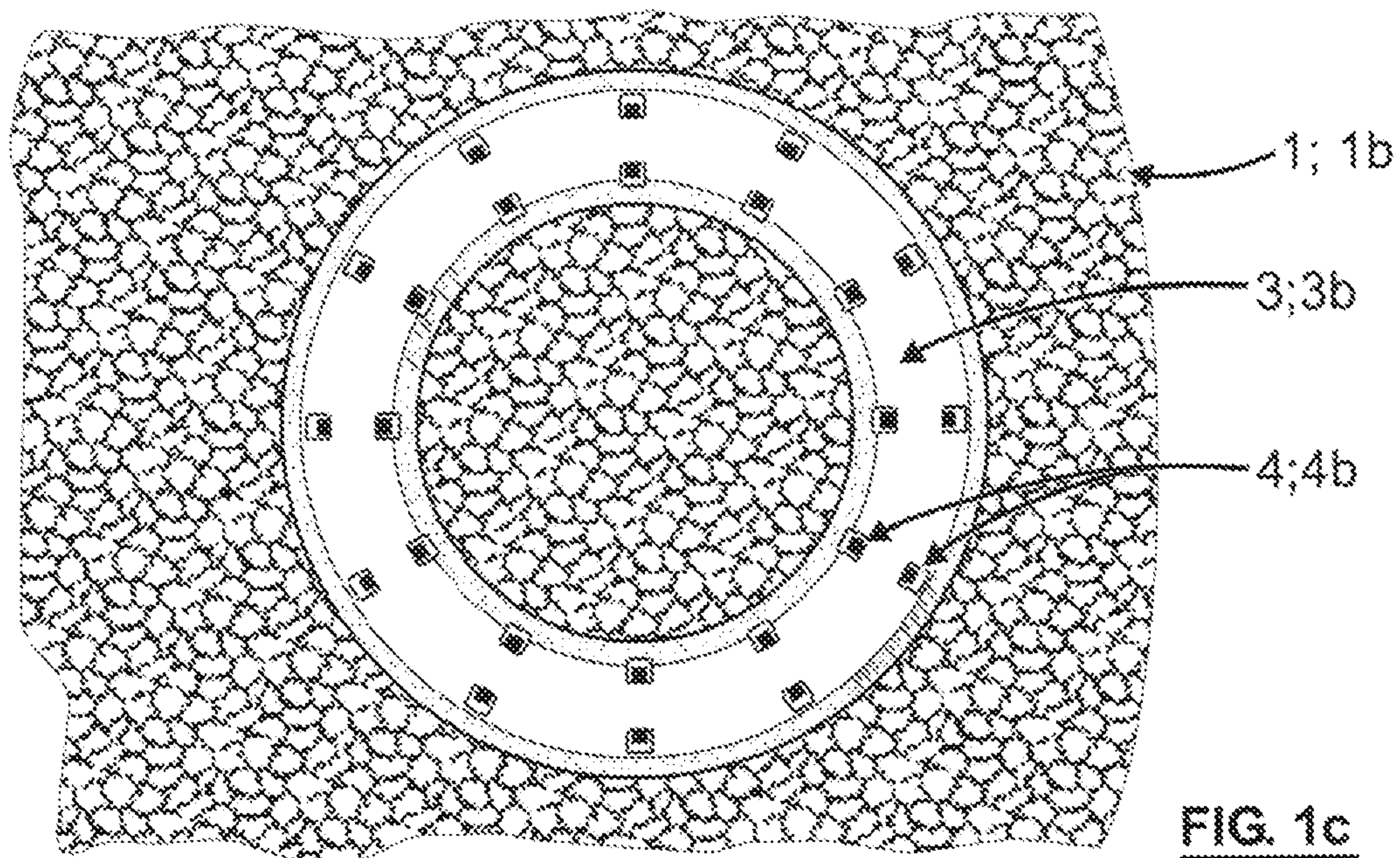
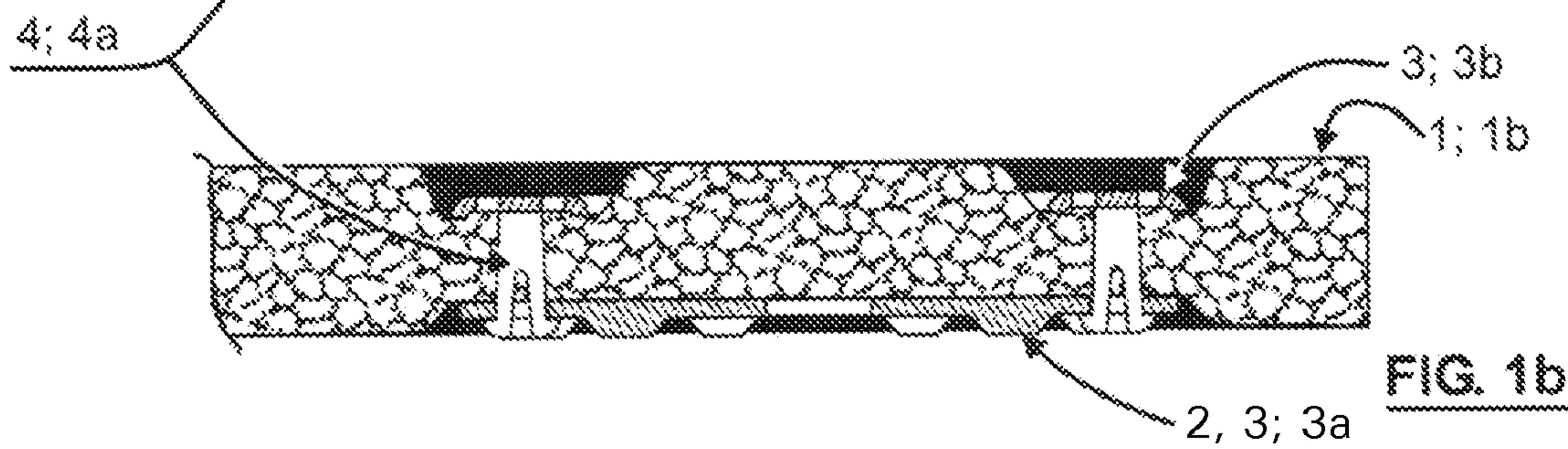
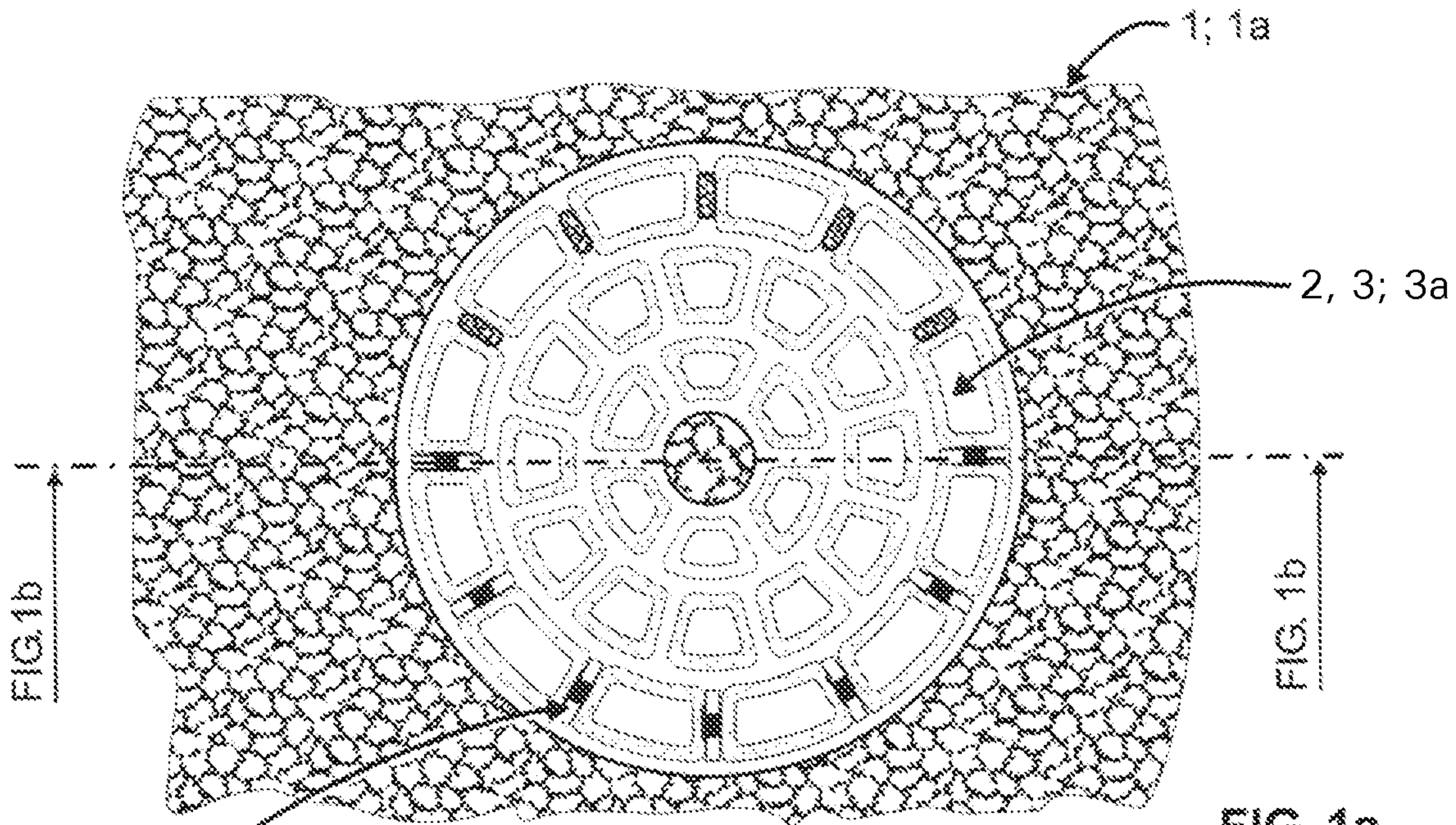
8. Arrangement according to any of the preceding claims 1-7, **characterized** in that, the fastening frame (3a) of the fastening means (3) is provided with means (6) for fastening of the grinding instrument (2) to the same chemically, such as by glueing, mechanically, such as by sticker gripping or snap lock jointing, melting, such as by welding, and/or in a corresponding manner.

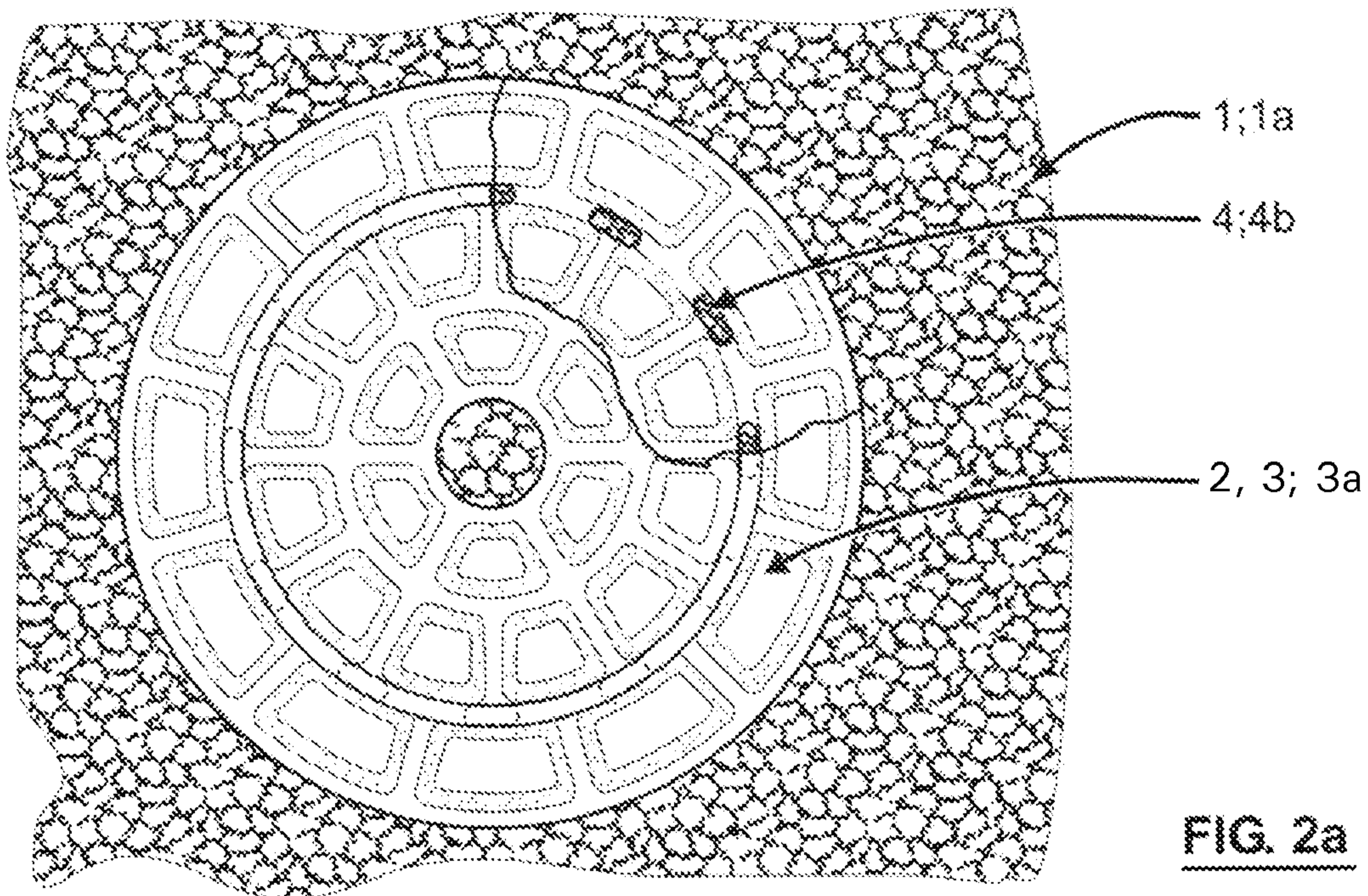
9. Arrangement according to any of the preceding claims 1-8, **characterized** in that, the fastening means (3) are arranged as a built-in entirety extending on opposite sides of the tool instrument (1) and being manufactured from elastic/flexible material, wherein the fastening and the auxiliary frames (3a, 3b) positioned against the front and back surfaces (1a, 1b) of the tool instrument, are provided with retaining

means (5) preferably extending inside the tool instrument.

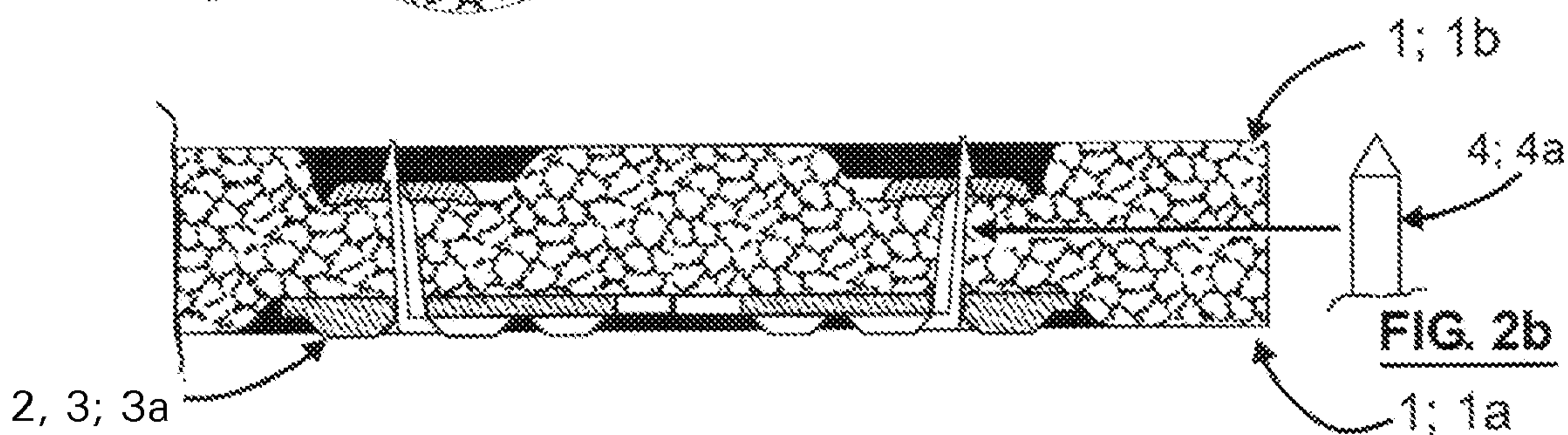
10. Arrangement according to claim 9,  
5 **characterized** in that, the fastening frame (3a) of the fastening means (3) is provided with an opening (A) at a corresponding point as the auxiliary frame (3b), when viewed in a direction of height (h) perpendicular to a plane defined by the tool instrument (1).

10

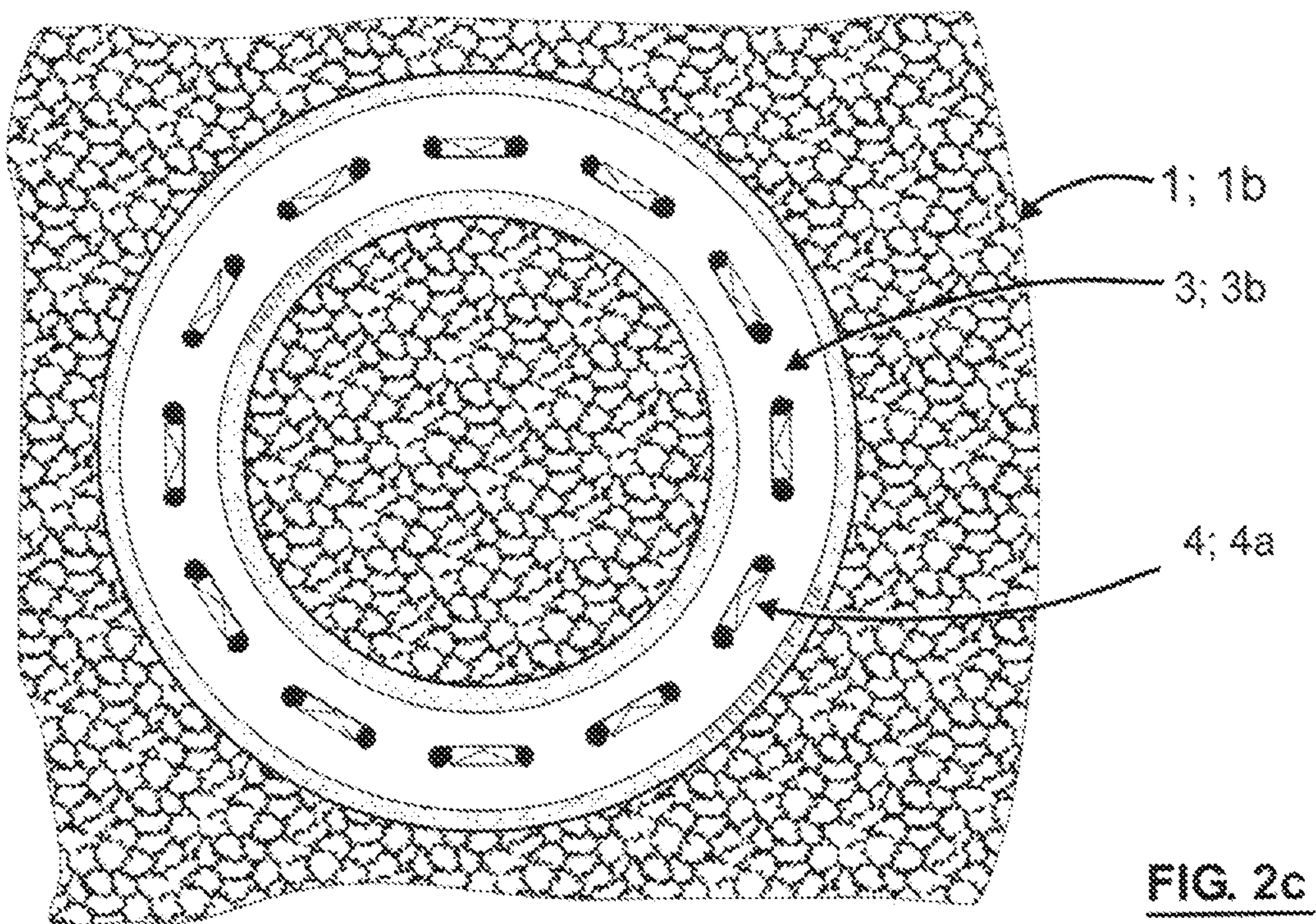




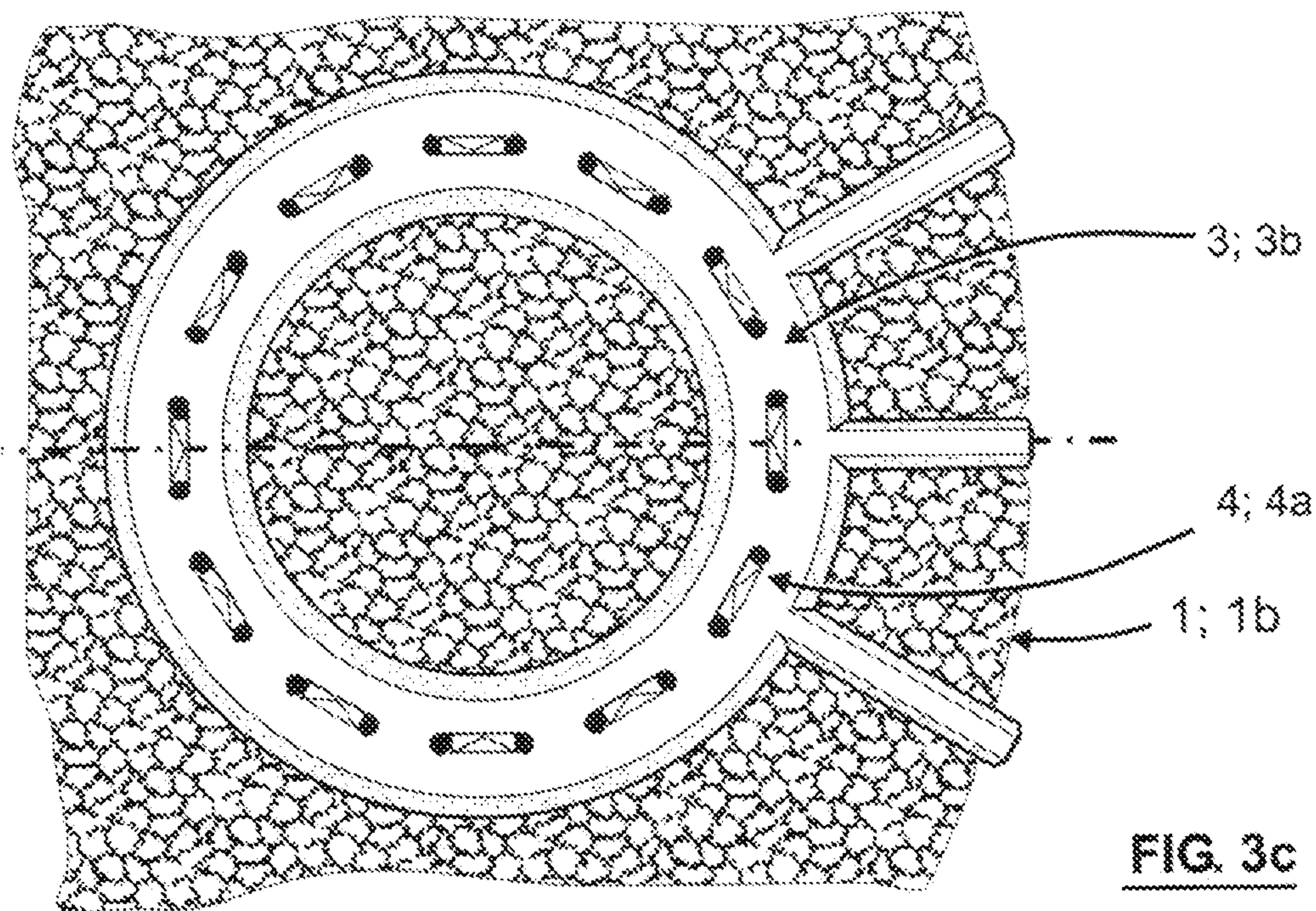
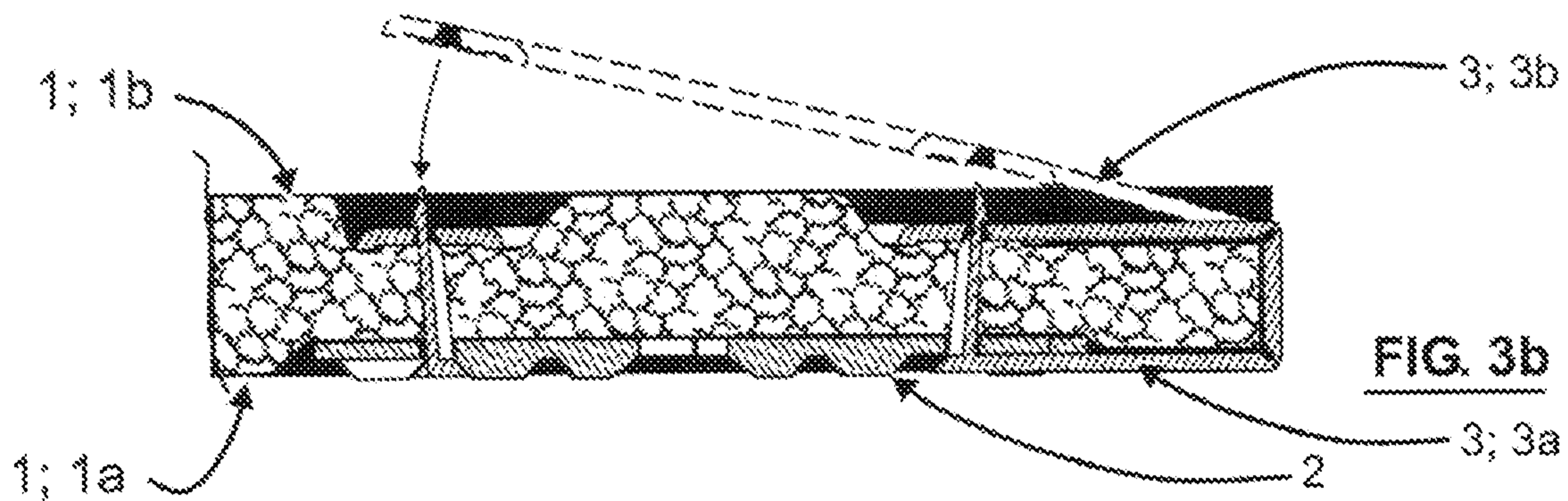
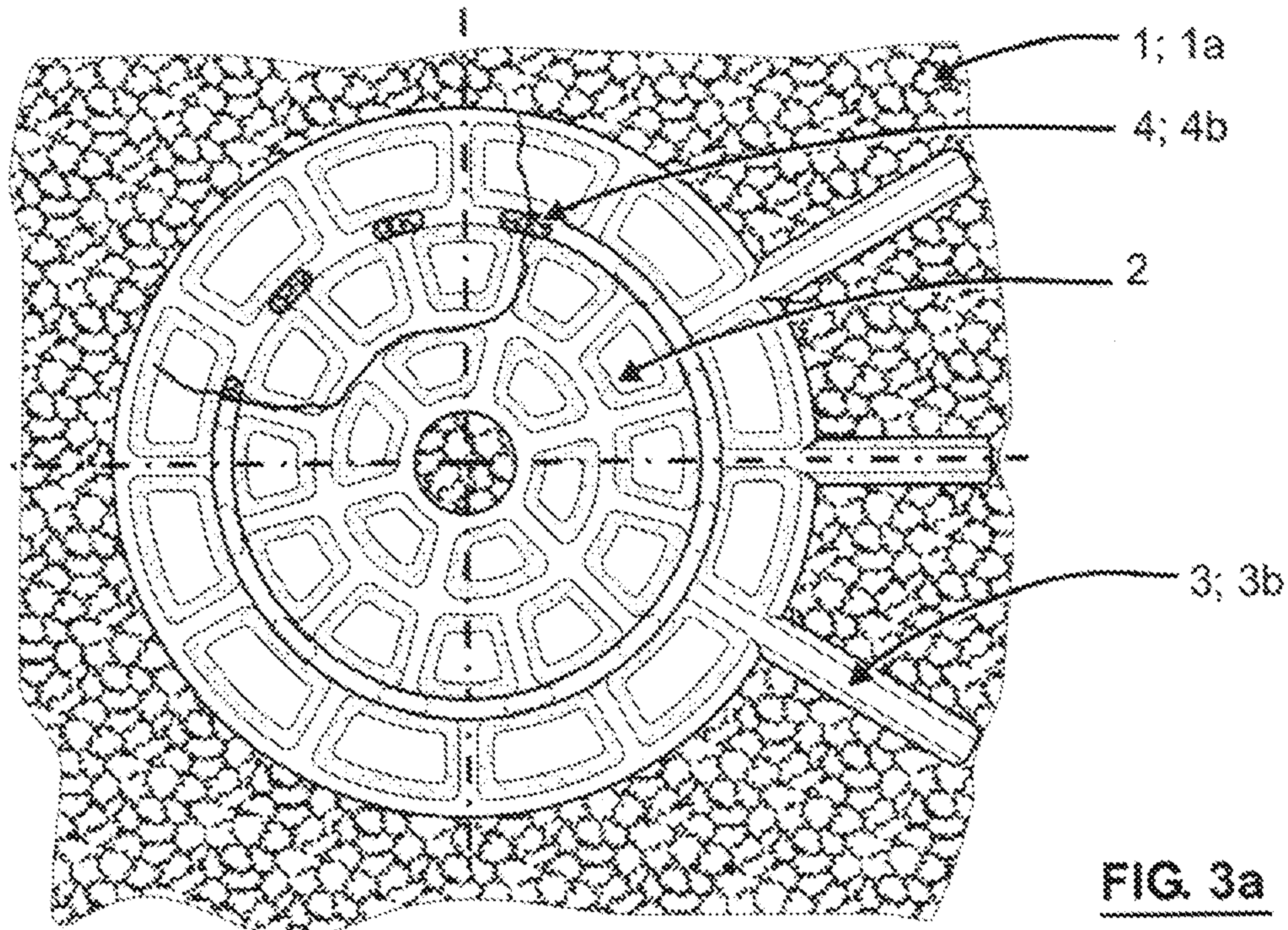
**FIG. 2a**



**FIG. 2b**



**FIG. 2c**



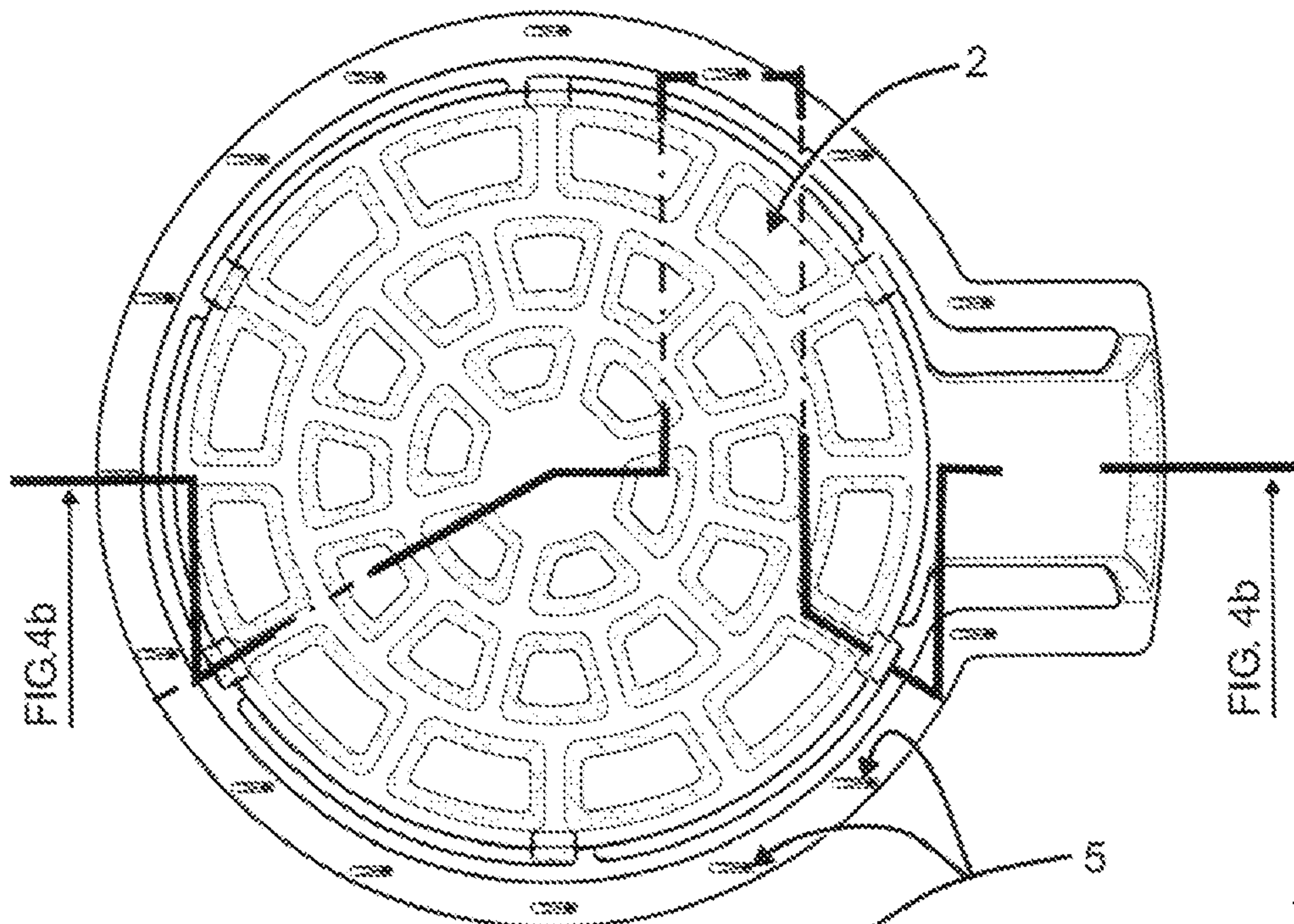


FIG. 4a

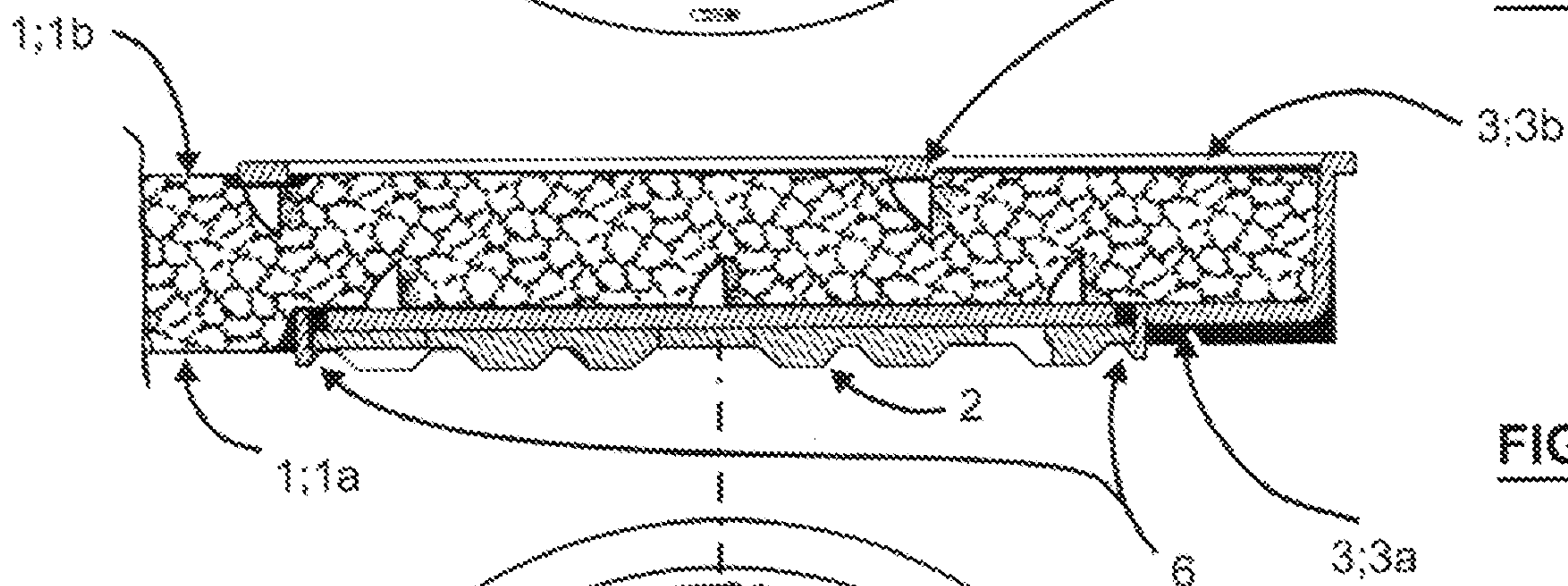


FIG. 4b

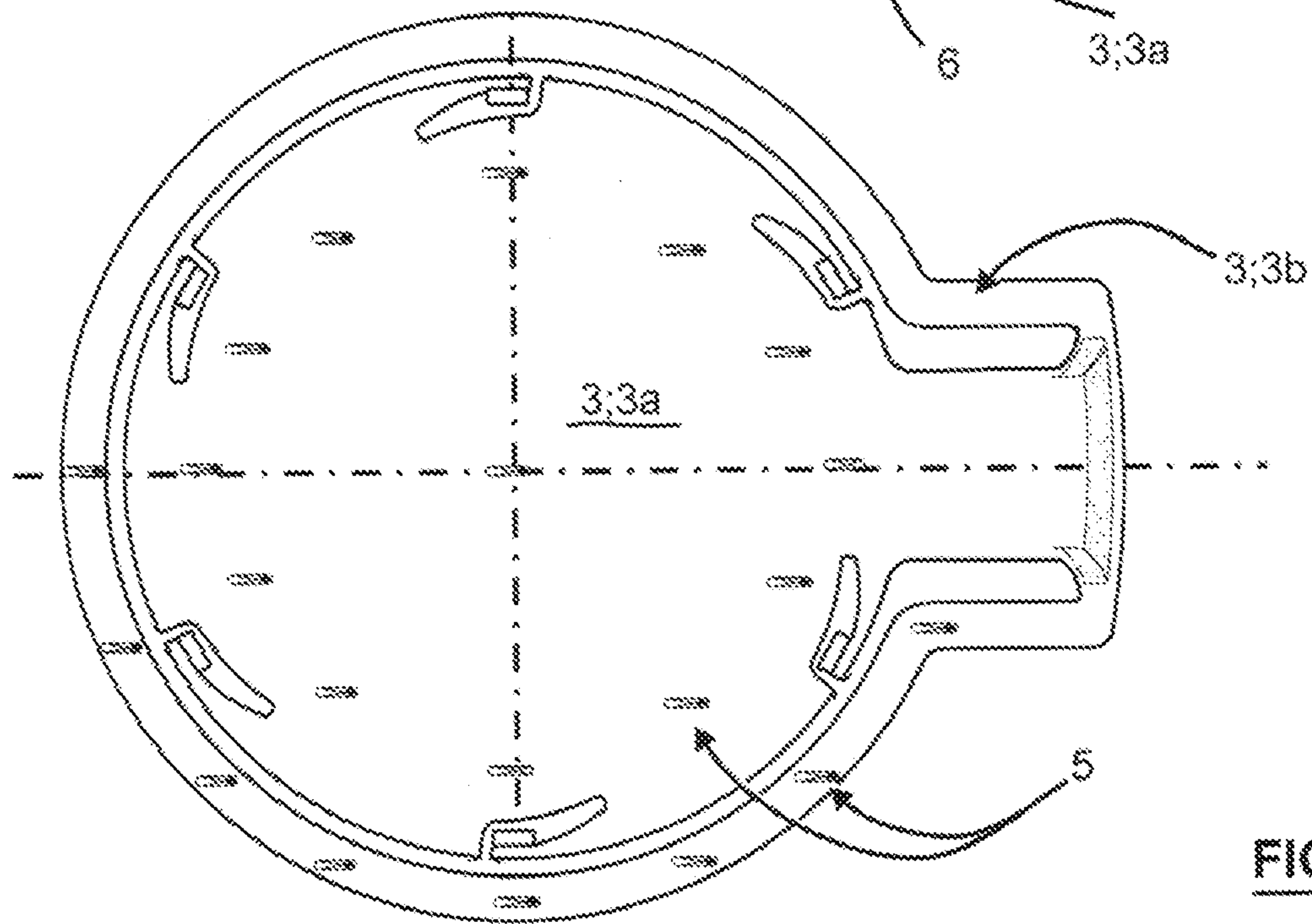
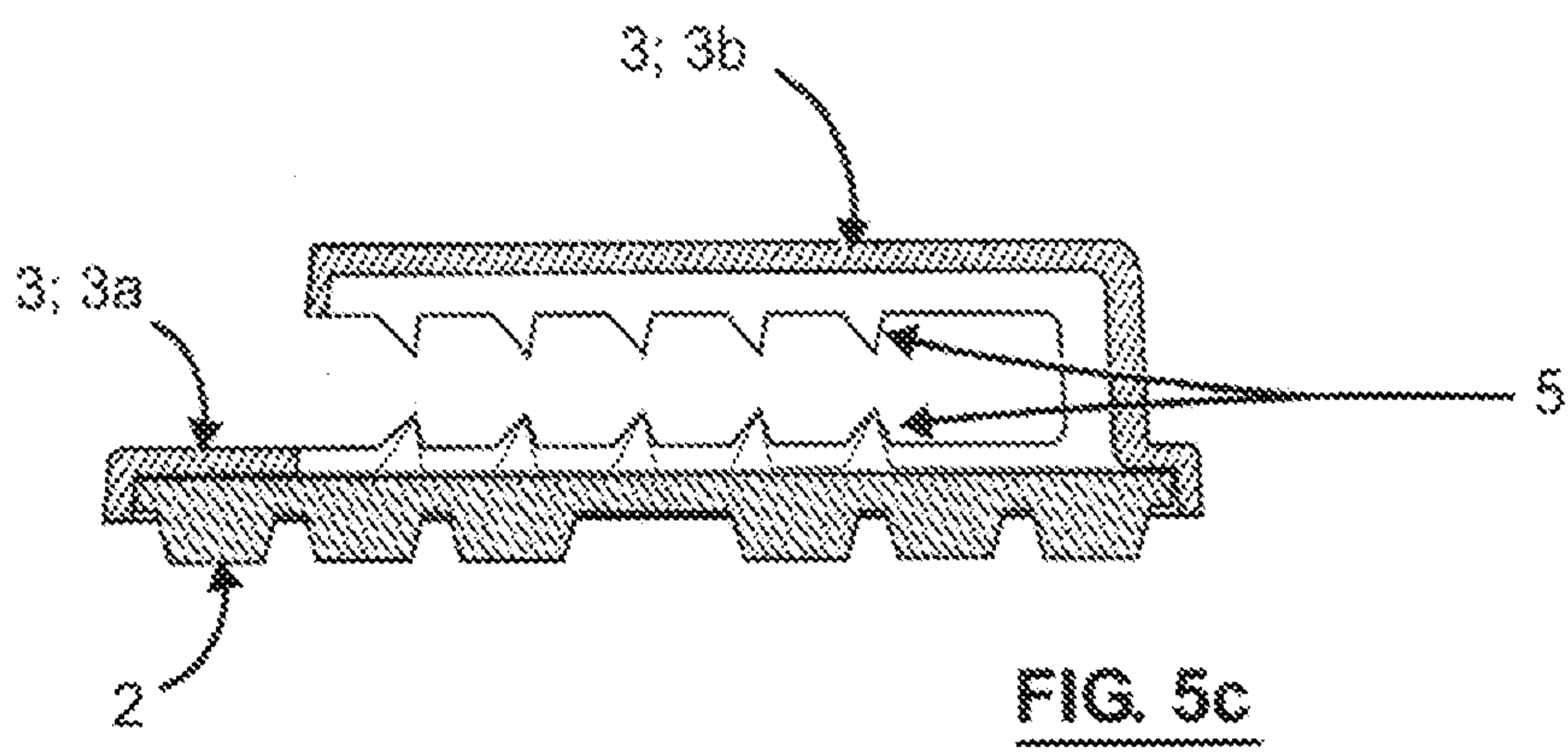
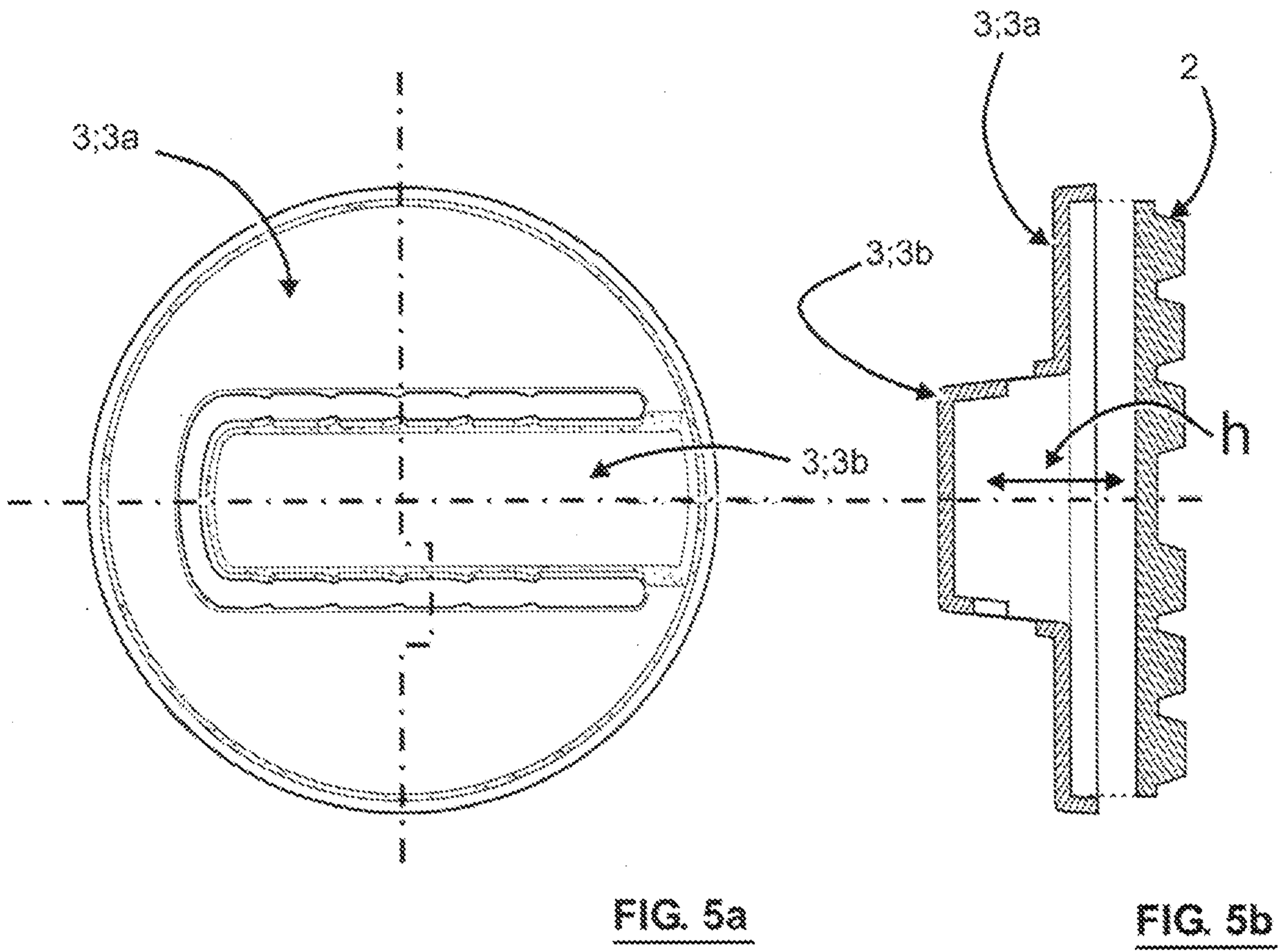


FIG. 4c



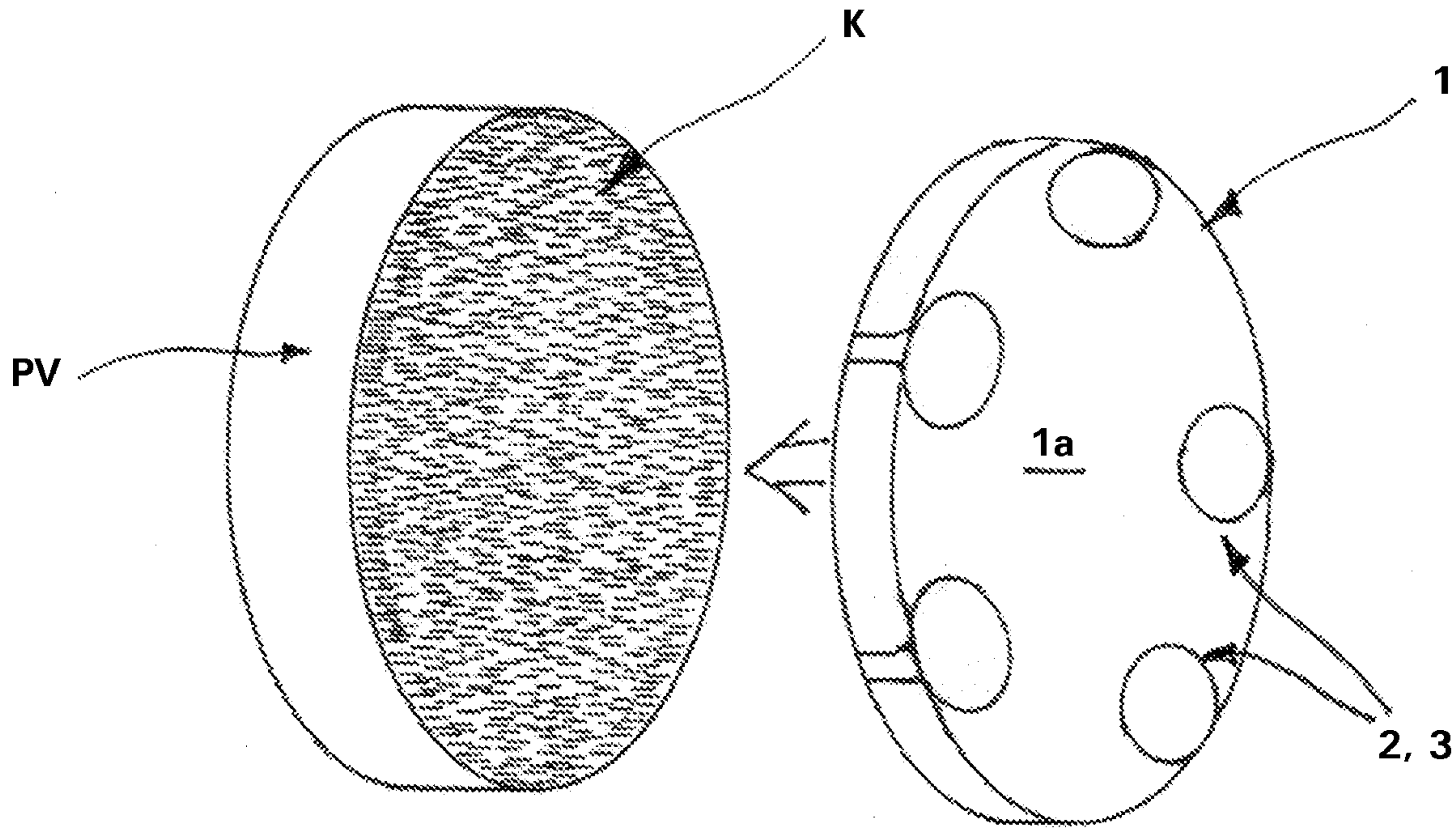


FIG. 6a

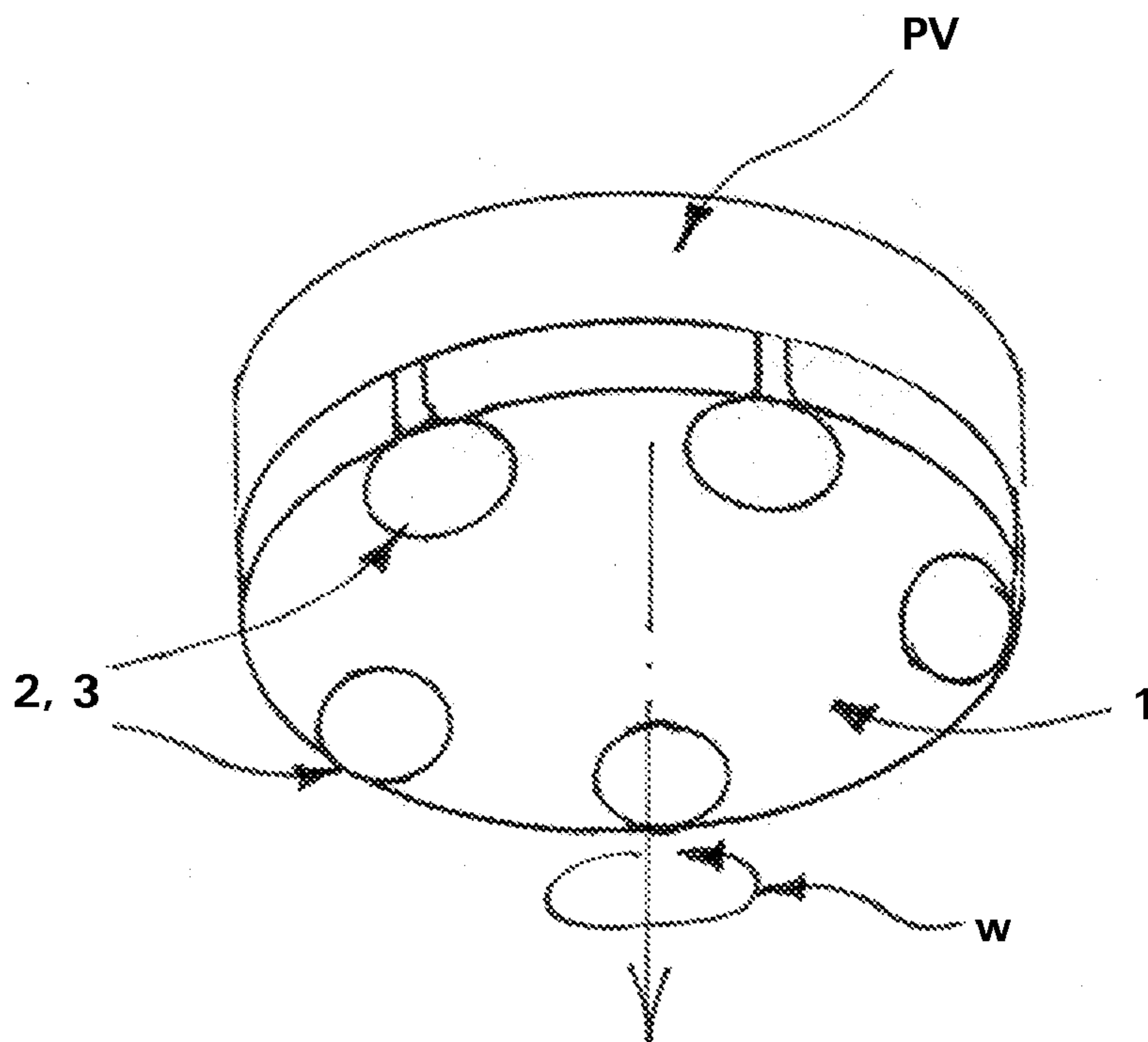
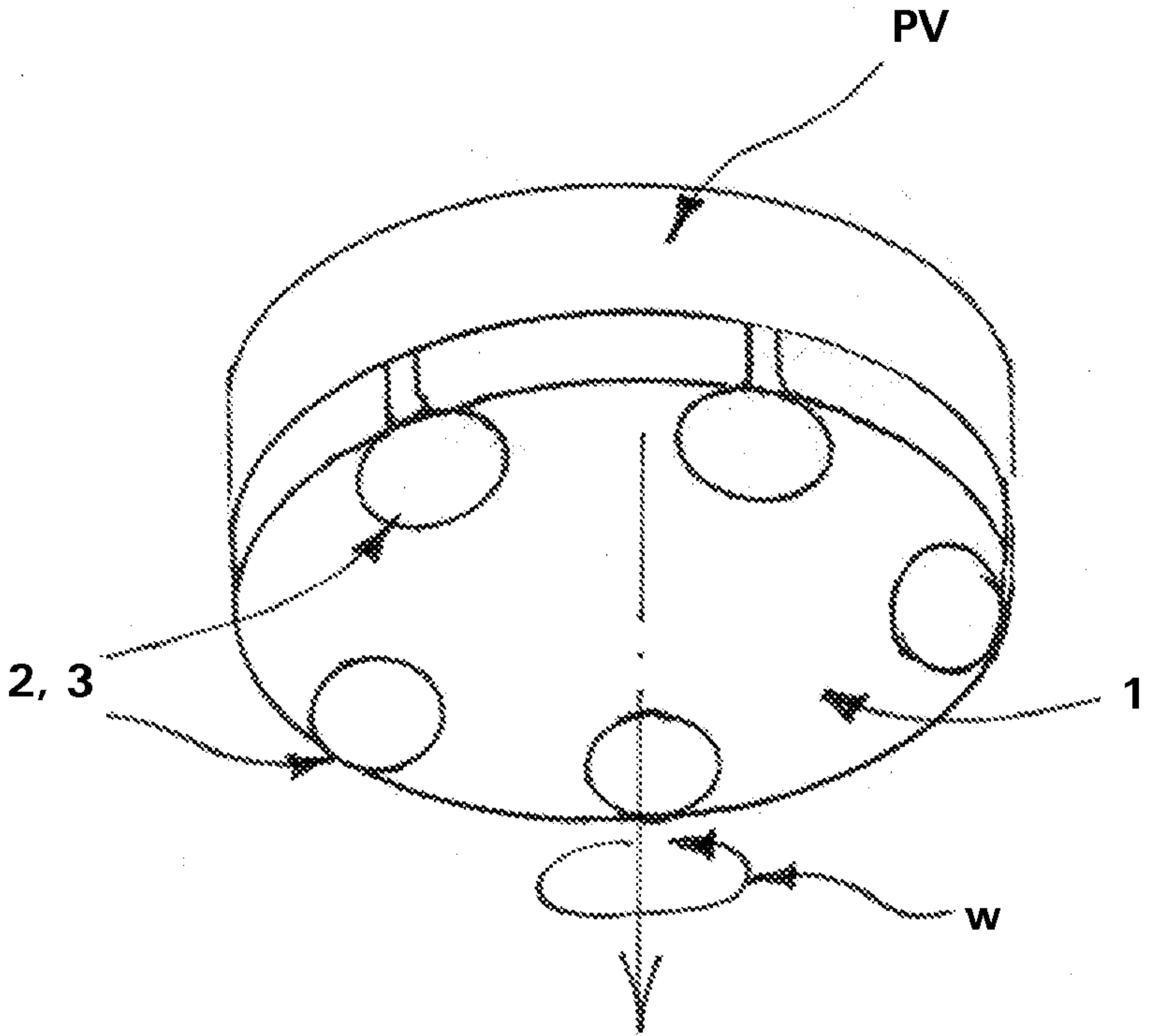


FIG. 6b



**FIG. 6b**

---