



US006427944B1

(12) **United States Patent**  
**Passman**

(10) **Patent No.:** **US 6,427,944 B1**  
(45) **Date of Patent:** **Aug. 6, 2002**

(54) **SYSTEMS AND METHODS FOR USING AIRBORNE COMMUNICATION NODES**

(75) Inventor: **William Scott Passman**, Lexington, MA (US)

(73) Assignee: **BBNT Solutions LLC**, Cambridge, MA (US)

(\* ) Notice: Subject to any disclaimer, the term of this patent is extended or adjusted under 35 U.S.C. 154(b) by 0 days.

4,315,666 A	2/1982	Hicks, Jr. ....	350/96.15
4,416,436 A	* 11/1983	Wilson, Jr. ....	244/137.1
4,592,605 A	6/1986	Kapler .....	339/8 R
4,848,867 A	7/1989	Kajioka et al. ....	350/96.21
4,875,646 A	* 10/1989	Browning et al. ....	244/190
4,909,589 A	3/1990	Morris .....	350/96.2
5,039,193 A	8/1991	Snow et al. ....	385/25
5,088,663 A	2/1992	Henson .....	244/137.4
5,542,012 A	7/1996	Fernandes et al. ....	385/25
5,722,618 A	3/1998	Jacobs et al. ....	244/137.1
6,061,562 A	* 5/2000	Martin et al. ....	455/431
6,086,015 A	* 7/2000	MacCready, Jr. ....	244/137.1

\* cited by examiner

(21) Appl. No.: **09/615,396**

(22) Filed: **Jul. 13, 2000**

(51) **Int. Cl.**<sup>7</sup> ..... **B64D 9/00**

(52) **U.S. Cl.** ..... **244/118.1**; 244/137.1; 244/138 R; 244/1 R

(58) **Field of Search** ..... 244/1 R, 118.1, 244/2, 3, 137.1, 138 R; 364/4, 14; 258/1.4, 1.1

(56) **References Cited**

**U.S. PATENT DOCUMENTS**

1,829,474 A	* 10/1931	Chilowsky .....	244/137.1
2,295,537 A	* 9/1942	Anderson .....	244/137.1
3,724,817 A	4/1973	Simons .....	258/1.4

*Primary Examiner*—Galen L. Barefoot  
(74) *Attorney, Agent, or Firm*—Leonard Charles Suchyta; James K. Weixel

(57) **ABSTRACT**

A method for providing a communication link from an aircraft (110) to a target (130) is provided. The method includes releasing a first end of a fiber optic cable (120) from an aircraft (110) and then lowering the first end of the fiber optic cable (120) to the target (130). The method also includes connecting the first end of the fiber optic cable (120) to a device at the target (130). The device at the target (130) may then communicate with devices on the aircraft (110).

**17 Claims, 5 Drawing Sheets**

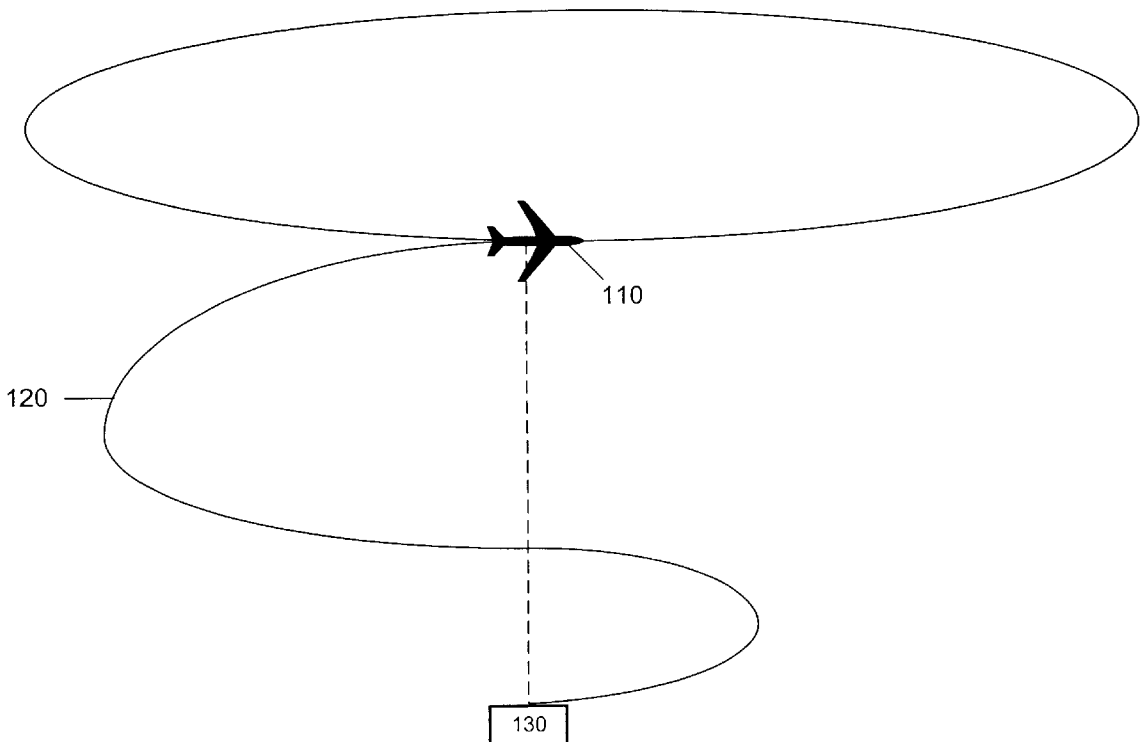

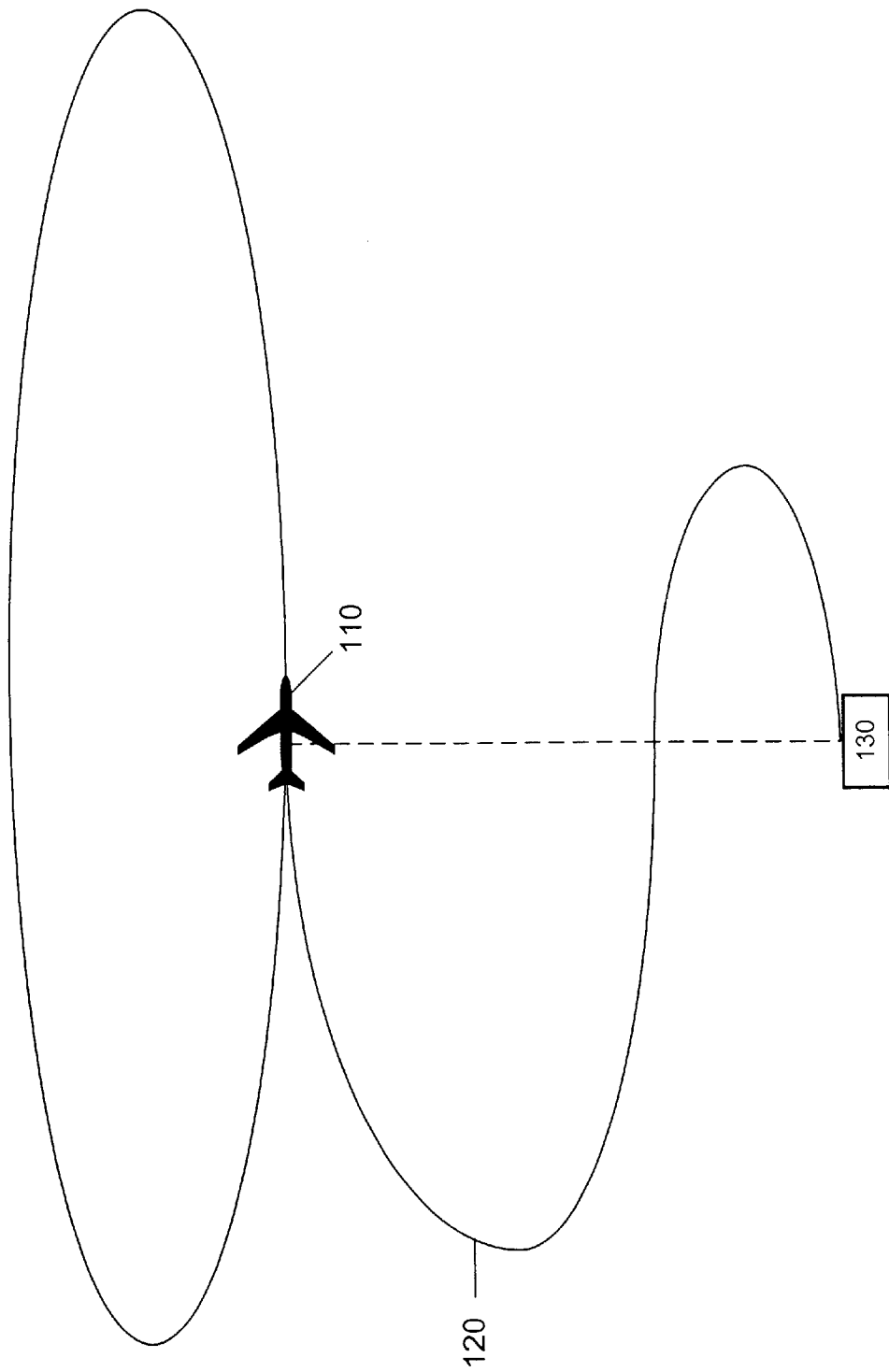

FIG. 1

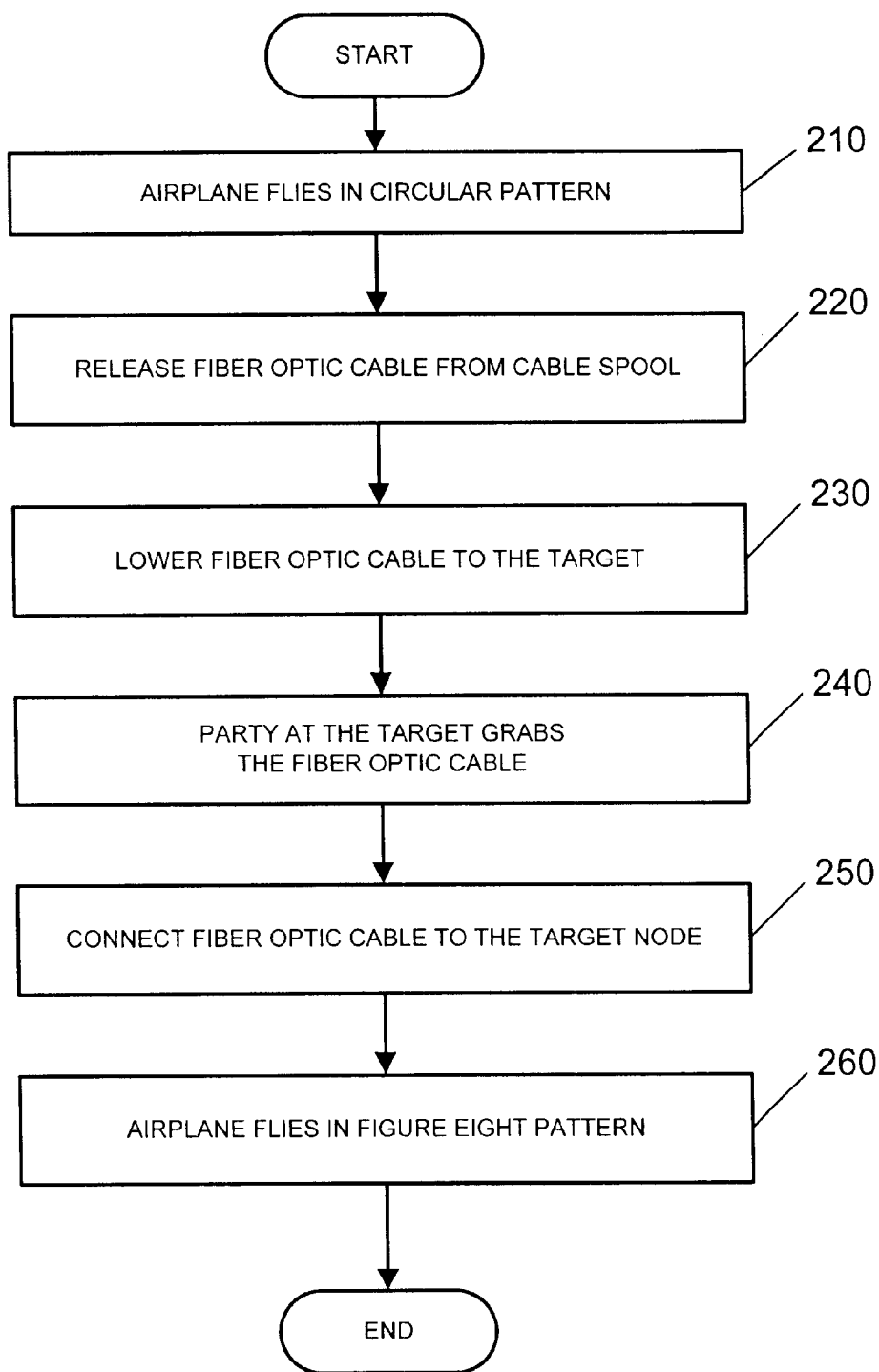

FIG. 2

300

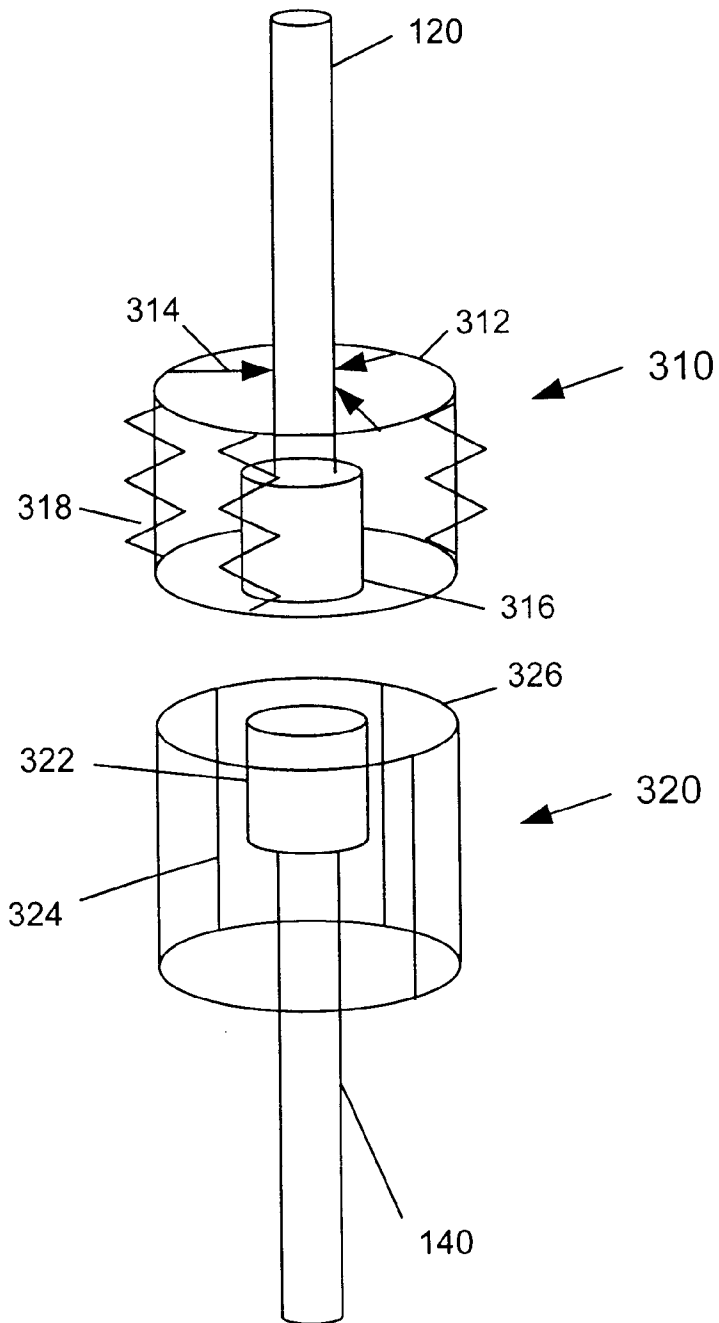

FIG. 3

300

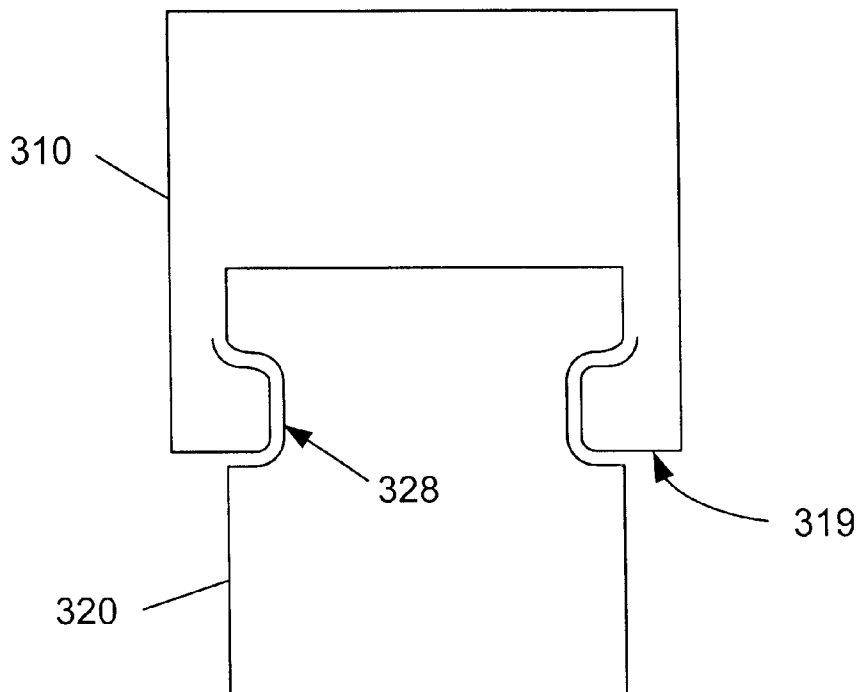

FIG. 4A

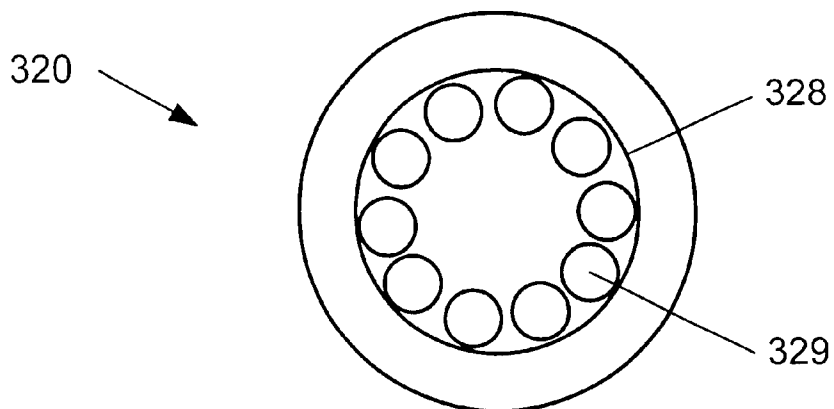

FIG. 4B

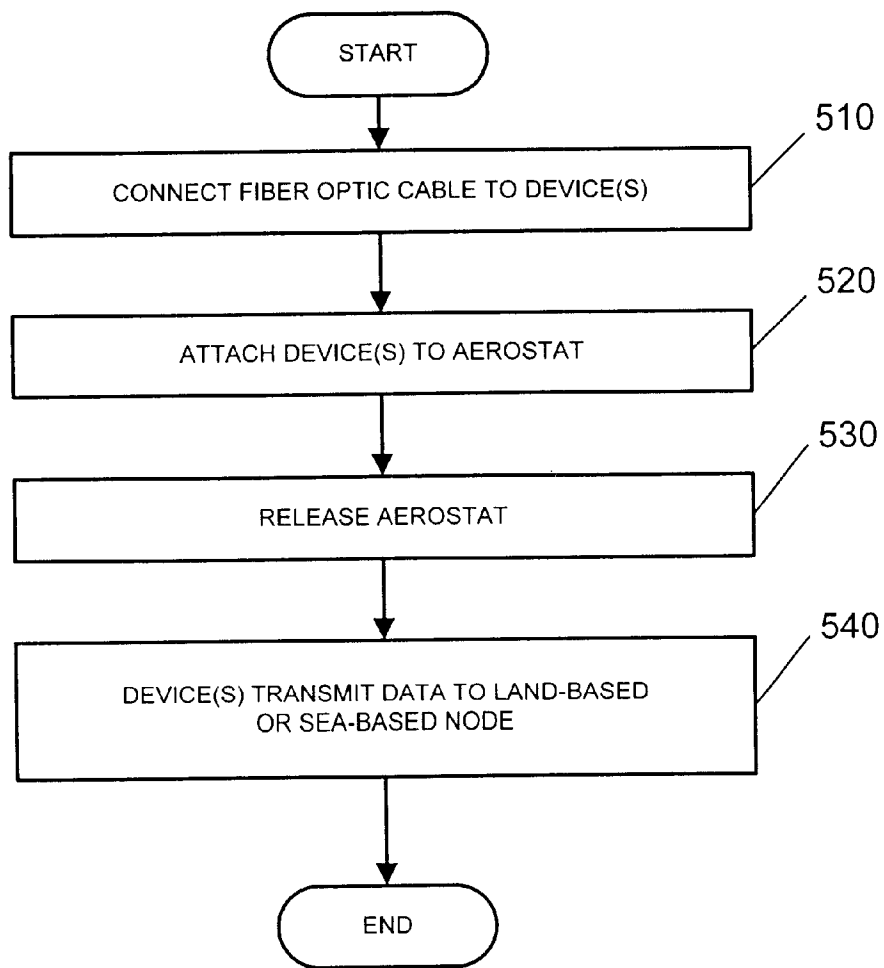

FIG. 5

## SYSTEMS AND METHODS FOR USING AIRBORNE COMMUNICATION NODES

### CROSS-REFERENCE TO RELATED APPLICATIONS

This application is related to the following commonly assigned, copending application U.S. Ser. No. 09/615,267 filed Jul. 13, 2000, entitled: METHOD AND APPARATUS FOR COUPLING FIBER OPTIC CABLES.

### FIELD OF THE INVENTION

The present invention relates generally to data communications and, more particularly, to communication systems and methods that utilize airborne nodes.

### BACKGROUND OF THE INVENTION

Aircraft are often used to deliver cargo to locations on the ground by dropping the cargo from the air. Over the years, various methods have been employed to increase the accuracy associated with releasing the cargo to a designated target area. For example, one prior art system discloses a method that uses a fixed wing airplane to deliver cargo to a specific point on the ground. In this system, the airplane flies in a circular pattern and unrolls a cable as it circles. The airplane is then stalled to allow the cargo to fall to a point on the ground located approximately in the center of the circle. This allows both delivery and pickup to a specific point on the ground.

Another prior art system adds sensors and controls to a payload to simplify delivery of the payload in more varied wind conditions. Such a system allows for some automatic positioning of the payload, thereby reducing the demands on the pilot.

These prior art systems disclose methods for delivering a payload from the air to a target location or picking up a payload from a target location. These prior systems, however, do not disclose techniques for delivering a communications medium to a particular location that may then be connected to a network and communicate with other nodes, such as an airborne communication node.

The use of such airborne communication nodes is very common today in the military and security operations. Typical airborne communication nodes use aerostats, e.g., blimps, to carry sensors and other electronic equipment. The aerostat is often tethered to the ground and flown a mile or more in the air to get a wide area of coverage. The higher the aerostat is flown, the greater the area of visibility. The equipment located in the aerostat then gathers data and transmits the data to ground-based equipment that may be part of a data network. In conventional systems that utilize airborne communication nodes, the data from the airborne node is typically communicated to the land-based nodes using wireless communications. However, in situations that require secure communications between the airborne node and the other nodes, such wireless transmissions are susceptible to being intercepted by unauthorized parties. Accordingly, wireless communications from an airborne node to other nodes are unsuitable for many applications.

Therefore, there exists a need for a method of providing a non-wireless communications link between an airborne node and a non-airborne node.

There also exists a need for a secure method of communicating from an airborne node to a non-airborne node.

### SUMMARY OF THE INVENTION

Systems and methods consistent with the present invention address these and other needs by delivering a commu-

nications link from an aircraft to a target. The communications link may then be connected to a data network. The communications link, consistent with the present invention, may be a fiber optic cable linking an airborne node and a non-airborne node, thereby increasing the security of the data transmitted between the nodes.

In accordance with the purpose of the invention as embodied and broadly described herein, a method for providing a communications link from an aircraft to a target is provided. The method includes releasing a first end of a fiber optic cable from the aircraft and lowering the first end of the fiber optic cable to the target. The method also includes connecting the first end of the fiber optic cable to a first device at the target.

In another aspect of the present invention, a method for connecting an airborne node to another node is provided in a network including at least one airborne node and at least one other node. The method includes releasing a fiber optic cable from an aircraft, lowering the fiber optic cable to a target near the other node and connecting a first end of the fiber optic cable to the other node. The method also includes attaching at least one device to a second end of the fiber optic cable, placing the at least one device in an aerostat and releasing the aerostat from the aircraft.

In still another aspect of the present invention, a method for providing a communication link from a first location to a second location is provided. The method includes releasing a first end of the communication link from an aircraft and lowering a first end of the communication link to the first location. The method also includes flying the aircraft to an area near the second location and releasing the second end of the communication link from the aircraft.

In yet another aspect of the present invention, a system is provided. The system includes an airborne node and at least one other node. The other node may be land-based or sea-based. The system also includes a fiber optic cable configured to connect the airborne node and the at least one other node to allow for communication between the nodes.

### BRIEF DESCRIPTION OF THE DRAWINGS

The accompanying drawings, which are incorporated in and constitute a part of this specification, illustrate an embodiment of the invention and, together with the description, explain the principles of the invention. In the drawings,

FIG. 1 illustrates an exemplary system in which methods and systems consistent with the present invention may be implemented;

FIG. 2 is a flowchart illustrating an exemplary method for providing a communications link to a designated target;

FIG. 3 is an exemplary connector, consistent with the present invention, for coupling two fiber optic cables;

FIG. 4A illustrates a profile of the connector of FIG. 3, according to an exemplary implementation of the present invention;

FIG. 4B illustrates an exemplary top view of a part of the connector of FIG. 3, according to an exemplary implementation of the present invention; and

FIG. 5 is an exemplary flowchart illustrating the use of an aerostat, according to an exemplary implementation of the present invention.

### DETAILED DESCRIPTION

The following detailed description of the invention refers to the accompanying drawings. The same reference numbers

in different drawings identify the same or similar elements. Also, the following detailed description does not limit the invention. Instead, the scope of the invention is defined by the appended claims.

Systems and methods consistent with the present invention provide an efficient method for delivering a communications link from an aircraft to a target that may be land-based or sea-based. The communications link may then be connected to a network interface device at the target location to communicate with other nodes, such as an airborne communication node. The communications link, consistent with the present invention, may be a fiber optic medium to further increase the security associated with transmitting data from the airborne node to other nodes.

#### EXEMPLARY METHOD FOR LINKING TO AN AIRBORNE NODE

FIG. 1 illustrates an exemplary system in which methods and systems consistent with the present invention may be implemented. The system 100 includes an airplane 110, a communications link 120 and a node 130. In FIG. 1, the airplane 110 represents an airborne node connected via communications link 120 to node 130. The airplane 110, also referred to as the airborne node, may be piloted or remotely controlled and may range in size from that of a very small remotely controlled drone to that of a large commercial jet. In alternative implementations, a helicopter or some other type of aircraft may be used instead of an airplane. The airplane 110 may include equipment, such as radar equipment, video equipment, transmitters/receivers, weather instruments, etc. for obtaining data. Such data may be transmitted to various personnel and systems located at other locations. For example, the data may be intended for transmission to node 130.

The node 130 may be a point on the ground where the communication link 120 may be connected to a network (not shown) so that the airborne node 110 may transmit and receive information to/from other nodes. Alternatively, the node 130 may be located on a ship in some body of water.

The communications link 120, consistent with the present invention, includes a conventional fiber optic cable. The communications link 120, also referred to as the fiber optic cable, may be coupled to the equipment on the airplane 110 through a network interface device, such as a network interface card, a router or a server-type device (not shown). Similarly, the communications link 120 may be coupled to equipment at node 130 through a similar network interface device. Data may then be transmitted from node 110 to node 130 via the fiber optic cable 120 in a conventional manner.

The node 130 provides a connection from the airborne node 110 to other nodes, networks or systems (not shown). The node 130, as described in more detail below, may include a connector that permits airborne node 110 and node 130 to remain adequately coupled even when the fiber optic cable 120 is moving.

#### EXEMPLARY METHOD FOR CONNECTING AN AIRBORNE NODE TO ANOTHER NODE IN A NETWORK

FIG. 2 illustrates an exemplary method for linking the airborne node 110 to other nodes/systems, such as node 130. The airplane 110, consistent with the present invention, includes a conventional cable spool. The particular length of cable may be based on the particular circumstances. The airplane 110 begins operations by flying in essentially a circular or elliptical flight path, as illustrated in FIG. 1 (step

210). The airplane's 110 particular flight speed may be calculated based on the physical properties of the fiber optic cable 120, such as the weight, to optimize the release of the fiber optic cable 120. Personnel in the cargo area of the airplane 110 then begin unrolling the fiber optic cable 120 from the cable spool so that the cable trails behind the airplane 110 (step 220). As the fiber optic cable 120 begins unrolling, the fiber optic cable 120 twirls like a jump rope or lasso, as shown in FIG. 1, as it trails the airplane 110. It should be noted that some points in the fiber optic cable 120 are static in horizontal motion as the airplane 110 circles. That is, there will be one or more points that remain directly under the center of the circular path in which the airplane 110 is flying.

The airplane 110 then slowly lowers its altitude until the end of the fiber optic cable 120 is directly over the target intended to receive the fiber optic cable 120 (step 230). The target may be a point on the ground or on a ship, such as node 130. A person at node 130, then grabs the end of the fiber optic cable 120 (step 240). Alternatively, the person grabs a small controller on the end of the fiber optic cable 120. This may be done by hand or with the assistance of a grabbing tool for safety. The person then attaches the cable 120 to an interface device at node 130 (step 250). The interface device may be any conventional device linking fiber optic cable 120 to other equipment.

In this manner, airborne node 110 and node 130 may be connected to allow data to be transmitted between the nodes. Additionally, since the communication link 120 is a fiber optic link, the airborne node 110 and node 130 may transmit data at rates in the gigabit/second range and above. Advantageously, the fiber optic cable 120 also provides a more secure communications link than conventional wireless links used to communicate from airborne nodes, which are susceptible to being intercepted or jammed by the enemy. According to an implementation consistent with the present invention, after the airborne node 110 is connected to node 130, the airplane 110 may change its circular flight path to a figure eight pattern (step 260). This figure eight pattern alleviates the problem of the fiber optic cable 120 twisting while the airplane 110 is connected to node 130. By flying in the figure eight pattern, the fiber optic cable 120 remains free of twists which could damage or even break the cable 120, thereby increasing the reliability of the link between the airborne node 110 and node 130.

According to another implementation consistent with the present invention, a connecting device may be used to ensure that the fiber optic cable 120 does not become twisted while the airborne node 110 is connected to node 130.

#### EXEMPLARY CONNECTION DEVICE FOR COUPLING FIBER OPTIC ABLES

FIG. 3 is a diagram illustrating an exemplary connector 300 that may be used to connect the fiber optic cable 120 to a device at node 130. The connector 300, consistent with the present invention, includes a rotating-side alignment device 310 and a fixed-side alignment device 320 used to couple the fiber optic cable 120 from the airplane 110 (FIG. 1) to a fiber optic cable 140 at node 130. The fiber optic cable 140 facilitates connecting the fiber optic cable 120 to equipment at node 130.

According to an exemplary implementation, the rotating-side alignment device 310 is cylindrical with an opening provided for fiber optic cable 120. The opening is sized to receive any fiber optical cable, such as fiber optic cable 120. The rotating-side alignment device 310 also includes a



5

mechanism for ensuring that the fiber optic cable 120 does not rotate independently of device 310.

For example, the top portion 312 of the rotating-side alignment device 310 may include one or more clamps 314 for rigidly securing the fiber optic cable 120 to the rotating-side alignment device 310. According to the exemplary implementation illustrated in FIG. 3, the rotating-side alignment device 310 uses three clamps 314 to secure the fiber optic cable 120. In other implementations, more or less clamps may be used, or any other mechanism may be used to ensure that the fiber optic cable 120 is rigidly secured to the rotating-side alignment device 310. For example, the opening in the rotating-side alignment device 310 may include a sleeve or collar that receives the fiber optic cable 120 and secures the fiber optic cable 120 to the device 310. The fiber optic cable 120 and the rotating-side alignment device 310 are then able to rotate together with respect to the fixed-side alignment device 320.

The bottom portion of the rotating-side alignment device 310, consistent with the present invention, may also include a conventional fiber connector 316 for receiving the fiber optic cable 120. In alternative implementations, the opening in the rotating-side alignment device 310 may run the entire length of the device and be sized to receive fiber optic cable 120 and fiber connector 316.

The rotating-side alignment device 310 may also include at least one spring 318 that runs essentially parallel to the fiber optic cable 120. The spring 318 helps ensure that the rotating-side alignment device 310 and the fixed-side alignment device 320 are kept in contact with each other. In the exemplary implementation illustrated in FIG. 3, three springs 318 are illustrated. Other numbers of springs 318 may be used in alternative implementations.

The fixed-side alignment device 320, consistent with the present invention, is cylindrical with an opening provided for a fiber optic cable. The opening is sized to receive any fiber optical cable, such as fiber optic cable 140. The top portion 326 of the fixed-side alignment device 320, consistent with the present invention, may also include a conventional fiber connector 322 for receiving the fiber optic cable 140. The fiber connector 322 may be similar to the fiber connector 316 provided in the rotating-side alignment device 310. In alternative implementations, the opening in the fixed-side alignment device 320 may run the entire length of the device and be sized to receive fiber optic cable 140 and fiber connector 322.

According to an exemplary implementation, the fixed-side alignment device 320 includes three rigid supports 324 for increasing the sturdiness of the device 320. The fixed-side alignment device 320 may optionally include clamps (not shown) for further securing the fiber optic cable 140 to device 320.

The fixed-side alignment device 320 is coupled to the rotating-side alignment device 310 so that the fibers 120 and 140 are aligned and are able to adequately transmit information without significant distortion or loss. According to the exemplary implementation, the rotating-side alignment device 310 rotates with the fiber optic cable 120 as the airplane 110 flies in a circular pattern. Advantageously, since both the fiber optic cable 120 and the rotating contact mechanism 310 rotate together, the fiber optic cable 120 does not twist, thereby reducing the chances that the fiber optic cable 120 will become damaged or break. In this manner, even when the airplane 110 flies in a tight circle, the fiber optic cable 120 does not twist.

FIG. 4A illustrates a side view of connector 300, consistent with an exemplary implementation of the present inven-

6

tion. Referring to FIG. 4A, the rotating-side alignment device 310 includes a lip or rim 319 that extends over a portion of the fixed-side alignment device 320. The fixed-side alignment device 320 includes a groove or slot 328 for receiving and securing the rim 319. In this manner, the rotating-side alignment device 310 and the fixed-side alignment device 320 are connected to permit the fiber optic cable 120 to transmit information to fiber optic cable 140.

FIG. 4B illustrates a top view of the fixed-side alignment device 320, according to an exemplary implementation of the present invention. As illustrated in FIG. 4B, the fixed-side alignment device 320 includes ball bearings 329 in a conventional ball bearing assembly to further facilitate movement of the rotating-side alignment device 310 in the groove 328. Alternatively, the groove 328 may be coated with Teflon or a similar material to reduce the friction associated with the rotating-side alignment device 310 rotating in groove 328.

In alternative implementations, the fixed-side alignment device 320 may include a lip that extends over a groove on the rotating-side alignment mechanism 310 to couple the two sides. In further alternatives, any number of mechanisms that would be obvious to one of ordinary skill in the art may be used to couple the rotating-side alignment device 310 to the fixed-side alignment device 320 to enable the rotating side to rotate freely with respect to the fixed side. It should be understood, however, that in any of these scenarios, the rotating-side alignment device 310 must be able to freely rotate with respect to the fixed-side alignment device 320 as the airplane 110 circles overhead, while remaining coupled and aligned with the fixed-side alignment device 320. In this manner, the fiber optic cable 120 and the rotating-side alignment device 310 rotate with the airplane 110, thereby alleviating stress on the cable 120 by ensuring that the fiber optic cable 120 does not become twisted. The fiber optic cable 140 may then be connected in any conventional manner to equipment at node 130.

According to an exemplary implementation, an optically transparent fluid or film may also be employed to further facilitate the coupling of fiber optic cables 120 and 140. For example, an optically transparent fluid or film may be inserted between fiber connectors 316 and 322 to reduce the wear associated with movement of the fiber connectors. The fluid or film may be applied to one or both of the surfaces of the connectors 316 and 322 that will contact the other respective fiber connector. For example, the fluid or film may be applied to the bottom surface of fiber connector 316 and to the top surface of fiber connector 322 to reduce the wear on the fiber connectors while they are contacting each other. Any particular fluid or film may be used that does not refract or reflect the optical transmissions between the fiber connectors 316 and 322.

After the connection from the airborne node 110 to the equipment at node 130 has been made, the airborne node 110 may continue to fly in a figure eight pattern or a circular pattern, depending on whether connector 300 is used. In additional implementations consistent with the present invention, an aerostat may also be used to provide a link to node 130.

#### EXEMPLARY METHOD FOR USING AN AEROSTAT TO COMMUNICATE WITH LAND OR SEA-BASED NODES

FIG. 5 illustrates an exemplary method for using an aerostat to communicate with node 130. After connecting the fiber optic cable 120 to node 130, a person in the airplane

**110** may attach various devices to the fiber optic cable **120** (step **510**). Such devices may include radio equipment, video equipment, sensors, weather observation equipment, etc, based on the user's particular requirements. In certain implementations of the present invention, the fiber optic cable **120** may first be coupled to an interface device, which is then coupled to the various data gathering devices in the airplane **110**. These devices, and the interface device if applicable, are then attached to the aerostat (step **520**). The aerostat is then released from the airplane **110** to float in the air above node **130** (step **530**). The particular altitude of the aerostat may be based on the particular user requirements. For example, in situations where the aerostat includes various video equipment, the length of fiber optic cable **120** may be set to allow the aerostat to float at an altitude above the tree line. It should be noted that fiber optic cable **120** may act as both a tether line and a communication link to node **130**. In alternative implementations, a separate tether line may be provided.

The particular equipment in the aerostat then gathers data and transmits this data to node **130** via fiber optic cable **120** (step **540**). Alternatively, the aerostat may receive control commands from node **130** to control the various equipment on the aerostat. Advantageously, such a system enables personnel at node **130** to have an airborne node **110** without requiring an airplane to remain in the area. Another advantage of using an aerostat is that it is less likely to be detected than an airplane. This is especially important in military or security operations. A further advantage of the invention is that deploying the aerostat from an airplane saves ground personnel from having to carry the aerostat and related equipment over rugged terrain, such as a mountain, in order to deploy an airborne node.

According to another implementation consistent with the present invention, the aerostat may be attached to the fiber optic cable **120**, as described above, and then another fiber optic cable may be attached from the airplane **110** to the aerostat. Alternatively, the aerostat and the airplane **110** may both be attached to fiber optic cable **120** via conventional splices. In either case, the airplane **110** then flies off connected to the aerostat. As the airplane **110** flies away, the fiber optic cable connecting the airplane **110** to the aerostat may sag and drape over the landscape. However, by connecting the aerostat to the airplane **110**, the range of connectivity of the aerostat would advantageously extend to devices such as radios, sensors, cameras and the like, on the airplane **110**.

According to a further implementation consistent with the present invention, the airplane **110** could also be used to deliver a communication link to two land-based or sea-based nodes. For example, suppose that the airplane **110** delivers one end of the fiber optic cable **120** to the target at node **130**, as described in relation to FIG. 2. The airplane **110** then flies away remaining connected to the fiber optic cable **120**. The fiber optic cable **120** may sag and drape over the landscape. The airplane **110** then deposits the other end of the fiber optic cable **120** to a second target location. For example, a parachute may be attached to the end of the fiber optic cable **120** and released over the second target destination. In wartime, this could allow for the rapid deployment of direct communication cables over long distances or otherwise over unpassable terrain.

The foregoing description of preferred embodiments of the present invention provides illustration and description, but is not intended to be exhaustive or to limit the invention to the precise form disclosed. Modifications and variations are possible in light of the above teachings or may be

acquired from practice of the invention. The scope of the invention is defined by the claims and their equivalents.

For example, the present invention is described in an environment where the connector **300** is used in conjunction with a fiber optic cable connected to an aircraft circling overhead. The connector **300**, however, may be used in other situations where a fiber optic cable may be moving, to provide relief from twisting cables. For example, connector **300** may be used in situations where a fiber optic cable is connected to a piece of equipment that may be rotating. The connector **300** may also be used in a situation where a fiber optic cable is being installed in a space that requires many turns, such as a home or office. In these situations, the connector **300** would eliminate the twisting of the fiber optic cable during the installation of the cable, thereby providing stress relief.

What is claimed is:

1. A method for providing a communications link from an aircraft to a target, comprising:

releasing a first end of a fiber optic cable from the aircraft;  
lowering the first end of the fiber optic cable to the target;  
and

connecting the first end of the fiber optic cable to a first device at the target, while the aircraft is in flight.

2. The method of claim 1, wherein the target is at least one of a land-based target and a sea-based target.

3. The method of claim 1, wherein the first device includes at least one of a node in a network, a network interface device, a communications interface device, a router, a server, and a computer.

4. The method of claim 1, further comprising:

connecting a second end of the fiber optic cable, located in the aircraft, to at least a second device; and  
transmitting information from the second device to the first device via the fiber optic cable.

5. The method of claim 4, wherein the second device includes at least one of radar equipment, video equipment, weather observation equipment and communications equipment.

6. The method of claim 4, further comprising:

flying the aircraft in a figure eight-type pattern to prevent twisting of the fiber optic cable.

7. The method of claim 1, further comprising:

connecting a second end of the fiber optic cable, located in the aircraft, to at least a second device;

placing the second device in an aerostat;

releasing the aerostat from the aircraft; and

transmitting information from the second device to the first device via the fiber optic cable.

8. The method of claim 7, further comprising:

connecting a second fiber optic cable from the aerostat to at least a third device on the aircraft; and

transmitting information from the third device to the first device via the second device.

9. In a network including at least one airborne node and at least one other node, a method for connecting the airborne node to the other node, comprising:

releasing a fiber optic cable from an aircraft;

lowering the fiber optic cable to a target near the other node;

connecting a first end of the fiber optic cable to the other node;

attaching at least one device to a second end of the fiber optic cable;

placing the at least one device in an aerostat; and

releasing the aerostat from the aircraft.

**9**

**10.** The method of claim **9**, wherein the at least one device comprises the airborne node and includes equipment for obtaining information, the method further comprising:  
 transmitting the information from the equipment to the other node via the fiber optic cable. 5

**11.** The method of claim **10**, further comprising:  
 transmitting control messages from the other node to the equipment via the fiber optic cable.

**12.** The method of claim **9**, further comprising: 10  
 connecting a second fiber optic cable to the aerostat;  
 flying the airplane to a second location;  
 obtaining information at the second location; and  
 transmitting the information from the second location to the aerostat via the second fiber optic cable. 15

**13.** A method for providing a communication link from a first location to a second location, comprising:  
 releasing a first end of a fiber optic cable from an aircraft;  
 lowering the first end of the fiber optic cable to the first location; 20  
 flying the aircraft to an area near the second location; and  
 releasing the second end of the fiber optic cable from the aircraft at the area near the second location.

**14.** The method of claim **13**, wherein the releasing 25 includes:  
 attaching a parachute to the second end of the fiber optic cable, and  
 releasing the parachute.

**10**

**15.** The method of claim **13**, further comprising:  
 connecting the first end of the fiber optic cable to a node in a network; and  
 connecting the second end of the fiber optic cable to another node in the network.

**16.** A system comprising:  
 an airborne node;  
 at least one other node, the at least one other node being at least one of a land-based node and a sea-based node;  
 a fiber optic cable configured to connect the airborne node and the at least one other node to allow for communication between the nodes; and  
 a connector configured to connect the fiber optic cable to the at least one other node while the airborne node is in flight.

**17.** A system comprising:  
 airborne communications means;  
 land-based communications means;  
 optical connection means for linking the airborne communications means and the land-based communications means; and  
 connector means for connecting the optical communication means to the land-based communication means while the airborne communication means is in flight.

\* \* \* \* \*