



Europäisches Patentamt  
European Patent Office  
Office européen des brevets



Publication number:

**0 595 905 B1**

12

## EUROPEAN PATENT SPECIFICATION

45 Date of publication of patent specification: **19.07.95** 51 Int. Cl.<sup>6</sup>: **B65B 9/13**, B65B 43/36

21 Application number: **92915712.1**

22 Date of filing: **20.07.92**

86 International application number:  
**PCT/EP92/01624**

87 International publication number:  
**WO 93/02924 (18.02.93 93/05)**

### 54 PACKAGING APPARATUS.

30 Priority: **26.07.91 NZ 239153**

43 Date of publication of application:  
**11.05.94 Bulletin 94/19**

45 Publication of the grant of the patent:  
**19.07.95 Bulletin 95/29**

84 Designated Contracting States:  
**AT BE CH DE DK ES FR GB GR IT LI LU MC  
NL SE**

56 References cited:  
**FR-A- 2 015 385  
GB-A- 1 137 057  
US-A- 3 161 002  
US-A- 3 908 343  
US-A- 4 346 546**

73 Proprietor: **MACHINERY DEVELOPMENTS  
LIMITED  
MDC House,  
142 Broadway  
Newmarket,  
Auckland 1001 (NZ)**

Proprietor: **WHITEHEAD, John Antony Baillie  
16 Highwood Grove  
Torbay,  
Auckland (NZ)**

72 Inventor: **MELVILLE, Richard, Archer  
8C Tagalad Road  
Mission Bay  
Auckland (NZ)**  
Inventor: **KELLY, Leonard, Stephen  
Manion Road  
Wyana Road  
Coromandel (NZ)**

74 Representative: **Dearing-Lambert, Peter Rich-  
ard  
P.O. Box 8  
Ibstock,  
Leicestershire LE67 6PO (GB)**

Note: Within nine months from the publication of the mention of the grant of the European patent, any person may give notice to the European Patent Office of opposition to the European patent granted. Notice of opposition shall be filed in a written reasoned statement. It shall not be deemed to have been filed until the opposition fee has been paid (Art. 99(1) European patent convention).

**EP 0 595 905 B1**

## Description

### FIELD OF THE INVENTION

This invention relates to a packaging apparatus. It has particular but not necessarily exclusive application to the factory packaging of joints of meat and other articles of somewhat variable size.

### BACKGROUND OF THE INVENTION

Machines are known which produce packages from a stock of material in the form of a flat elongate tube (typically of paper or plastics) wound into a coil. In such machines the leading end of the tube is fed off the coil and passed through mechanisms which cut the tube transversely to separate the leading end thereof from the stock and seal the transverse edge of the leading end to form a bag. It is known to provide such machines with suction devices for opening the package so that it is ready for use.

A machine of this kind is disclosed in US patent #3557526 to Hartmann. This machine appears to be designed for the automatic packaging of long runs of articles which are substantially identical one to the other. It is provided with a pair of drive rollers which feed a short length of the leading end of the tube off the coil; a cutting and sealing mechanism; and a pair of selenium cells which are positioned in front of the drive rollers. All of these components are mounted on a common mounting which can be movably positioned on the frame of the machine. The drive rollers are brought to a halt when the front edge of the tube passes between the selenium cells. At this juncture a gripping device grabs the leading end just behind its front edge and draws more of the tube off the coil. At the same time the front edge is opened by a pair of suction devices. The gripping device positions the front edge always at the same location where, after the cutting and sealing mechanism is actuated to form a bag by separating the leading end from the tube and sealing the back edge thereof, an article is fed into the open end of the bag.

The bag length can be adjusted by repositioning the common mounting on which the cutting device and the other aforementioned components are mounted. The means by which such adjustment is made are not described in detail but it is suggested that screws may be used to secure the mounting on the frame.

The applicants do not believe that this machine is suitable for rapid changing of the bag length to suit articles such as cuts of meat whose lengths can vary from one article to the next.

## SUMMARY OF THE INVENTION

According to the invention there is provided apparatus of the kind used to produce packages from a stock of flexible laminar packaging material in the form of an elongate tube in a packaging operation in which articles are packaged as the packages are made, the apparatus comprising tube feed means and tube cut-off means which can be operated to produce said packages by successively feeding leading portions of the tube off the stock and separating said leading portions from the stock, characterised in that the apparatus includes control means for controlling the operation of the tube feed means which control means can be readily adjusted so as to cause the tube feed means to vary the length of each said leading portion as it is produced to suit the length of each article to be packaged.

Further according to the invention, there is provided a method of producing packages from a stock of flexible laminar packaging material in the form of an elongate tube for a packaging operation in which the articles are packaged as the packages are made, the apparatus comprising tube feed means and tube cut-off means which can be operated to produce said packages by successively feeding leading portions of the tube off the stock and separating said leading portions from the stock, characterised in that the method includes the steps of providing control means for controlling the operation of the tube feed means, which control means are readily adjustable to cause the tube feed means to vary the lengths of said leading portions as they are produced to suit the length of each article to be packaged.

In one form of the invention the control means includes a carriage and means for positioning the carriage at a variable distance from the tube feed means, detecting means mountable on the carriage and providing a signal upon detecting the arrival of a said leading portion at the carriage, and disabling means arranged in response to said signal to interrupt the operation of the tube feed means.

In one aspect of the invention the control means includes an operator activated switch for starting the operation of the tube feed means.

In another aspect of the invention the carriage is movably mounted on a track and the means for positioning the carriage comprises operator releasable brake means for holding the carriage in position on the track.

In yet another aspect of the invention the means for positioning the carriage comprises a ram to which the carriage is connected, and the control means positions the carriage by extending or retracting the ram.

In one form of the invention at least two endless belts are provided which collectively provide a moving surface on which said leading portions of the tube are supported as they move towards the carriage.

In one aspect of the invention the carriage comprises a suction device arranged to apply suction to a first layer of a said leading portion of the tube, and means to separate a second layer thereof from the first layer.

In one form of the invention heat sealing means is provided adjacent the cut-off means for sealing a rear edge of the leading portion of the tube.

Advantageously the tube feed means comprises a pair of rolls which feed the tube past the cut-off means, and means for momentarily reversing the rolls after actuation of the cut-off means so that a forward edge of the stock formed by actuation of the cut-off means is drawn back from the cut-off means before being fed forward past the cut off means.

#### BRIEF DESCRIPTION OF THE DRAWINGS

The invention is further discussed with reference to the accompanying drawings in which

Figure 1 is a somewhat schematic sectional side view of a packaging apparatus;

Figure 2 is a plan view of the apparatus shown in Figure 1;

Figure 3 is a detailed sectional view of the manner of mounting a pair of drive rolls;

Figure 4 is a detailed sectional view of a heat sealing and cut off mechanism;

Figure 5 is a detailed view of the manner of positioning a tube opening mechanism of the apparatus.

Figure 6 is a sectional view of an alternative arrangement for the drive rolls;

Figure 7 is a sectional side view of a modified apparatus;

Figure 8 is a plan view of the apparatus shown in Figure 7; and

Figure 9 is a partial side view of another modified apparatus.

#### DETAILED DESCRIPTION OF THE EMBODIMENTS SHOWN IN THE DRAWINGS

Referring to Figures 1 to 5 the apparatus 10 comprises number of interactive mechanisms mounted on a frame 11. These mechanisms include a spindle assembly 12 which carries a roll 13 of heat sealable plastics film in the form of a flat tube T. The tube T is fed from the roll to a drive roller assembly 14 located at what will be called the feed end of the frame. For clarity only two rolls

24, 25 of this assembly are shown in Figure 1. The drive roller assembly 14 feeds the tube T past a heat sealing and cut-off mechanism 15 and over an assembly of endless belts 17 mounted between drums 18, 19. The drum 18 is located adjacent the mechanism 15 and the drum 19 is located adjacent the opposite end of the frame. A tube opening mechanism 16 is located between the drums 18, 19.

The spindle assembly 12 comprises a spindle 21 provided with bearings on which are mounted a cardboard tube located at the centre of the roll 13. The roll thus rotates about the spindle. The spindle also carries disc shaped plates 22 mounted at each end of the roll. The plates rest on cross members 23 mounted on the frame 11. The tube T can thus feed freely off the roll and the spindle assembly can be lifted off the cross members for easy replacement of the roll 13.

Referring particularly to Figure 3, the drive roller assembly 14 comprises upper and lower drive rolls 24, 25 mounted, in the present example, in bearing blocks 27, 28 of self lubricating plastics material such as Teflon™. The lower roll is driven through a sprocket chain 75 by an electric motor/gear box assembly indicated at 26. The upper roll is geared to the lower roll. The bearing blocks are mounted in vertical slide rails 29, 29a fixed to plates mounted on the frame. Compression springs 31 are mounted in recesses in the bearing blocks and tend to force the bearing blocks apart. The blocks are retained in place by toggles 32. The inner end of each toggle is provided with a pin 60 which is hooked into a recess adjacent the upper end of each inner slide rail 29. The outer end of each toggle is drawn downwardly by an over-centre catch arrangement. This comprises a screw threaded catch 61 which engages the lower end of a leg 62 pivoted at 63 to a handle 64. The handle is in turn pivoted at 65 to the toggle. The length of the leg and catch assembly can be adjusted by turning the catch 61 in the leg 62. The catch has a T shaped head 66 which, when the handle is raised, engages a hook 67 mounted on the frame 11. When the handle is lowered the toggle is drawn downwardly against the upper block 27 and the parts are locked in place by the over centre motion of the handle and leg. Pressure is applied to the upper roll 24 by the toggles. The upper roll in turn bears on the lower roll 25 with a pressure which can be altered by adjusting the length of the legs 62. When the toggles are released the upper roll 24 is lifted by the springs 31 thus enabling the leading end of a tube T from a fresh roll 13 to be passed between the rolls 24, 25. The adjustability of the catch assemblies is important to enable the apparatus to handle film of varying characteristics. Moreover, the pressure applied to each end of the

rolls can be independently adjusted. This is important since it enables the direction in which the tube is fed out of the rolls to be accurately adjusted.

The heat sealing and cut-off mechanism 15 comprises a guillotine-like blade 33 mounted on a cross bar 34. Upwardly projecting studs 35 are fixed on the cross bar and slide in a cross plate 36 mounted on the frame 11. Between the cross bar 34 and the cross plate 36, a washer plate 37, an air bag 39, springs 38 and a block 41 are slidably mounted over the studs. The air bag is connected through a connector 39a by suitable pipe work (not shown) to a source of compressed air. A conventional, electrically operated shut off valve mounted in the pipe work controls the supply of air to the air bag. Two clamping bars 40 are mounted on the lower face of the block 41 and located one on either side of the cross bar 34. The cross bar 34 is located in a recess 41a in the block.

An aluminium plate 42 is mounted on the frame 11 below the cross bar 34. The plate has an upper face 43 which is aligned with the line of contact between the drive rolls 24, 25. A nichrome ribbon 44 sandwiched between two layers of Teflon™ tape is laid on the face 43 directly underneath the inner clamping bar 40. The nichrome wire is connected to a source of electrical power through a switching arrangement which will be discussed in greater detail below. There is a space 45 between the face 43 and the clamping bars through which the tube T passes as it feeds out of the drive roller assembly 14. As will be discussed below in detail, the tube T is stopped at intervals for the purpose of forming a bag in the tube T. This is achieved by inflating the air bag 39 which advances the studs 35 downwardly until the clamping bars 40 come up against the plate 42, clamping the tube T against the face 43. At this stage the nichrome bar is heated and causes the upper and lower layers of the tube T to weld together. The Teflon™ tape around the nichrome ribbon helps to prevent the tube T from adhering to the plate 42. Inflation of the air bag continues. The cross bar 34 and blade 33 are hence driven downwardly in the recess 41a against the action of the springs 38 so that the blade 33 severs the tube T. When the air bag is deflated the blade 33 and the clamping bars are retracted into the recess.

The upper bights of the belts 17 collectively constitute a moving surface S at the top of the frame. The drums 18, 19 are positioned so that this surface S lies in substantially the same plane as the upper face 43 of the plate 42. The drum 19 is located at a higher level than the drum 18 so that the surface S slopes upwardly from the tube feeding end of the frame. The drum 18 is driven through a sprocket chain 75a by the same motor/gear box assembly 26 that drives the drive roll

24, the speed of the surface S being equal to or greater than the peripheral speed of the roll 24. Consequently the tube T encounters no friction as it advances across the top of the frame; moreover the belts tend to keep it advancing in a straight line until the leading edge of the tube T arrives at the tube opening assembly 16.

The assembly 16 is located between the two centre belts 17. The assembly 16 comprises a plate 70 on which are mounted a proximity sensor 46; a vacuum head 47 connected through a flexible hose to a vacuum pump 48; and a bag opening head 49 connected to a source of compressed air (not shown). The vacuum head is located between the mechanism 15 and the bag opening head and the nozzle 47a of the vacuum head is positioned flush with or just below the moving surface S. When the proximity sensor senses the arrival of the leading edge of the tube T, the drive roller mechanism is stopped and the heat sealing and cut-off mechanism 15 is actuated (as will be further described below). The vacuum head is also actuated. The lower layer of film in the tube T is sucked against the nozzle 47a. The nozzle is preferably of substantial area, in the present example, about 12 sq. cm. The lower layer of film, where it is sucked against the nozzle, is drawn away from the upper layer. This materially assists the separation of the two layers and reduces the likelihood of the lower layer becoming detached from the vacuum nozzle.

In the example illustrated the suction of the vacuum head is controlled by means of a butterfly valve in the throat of the head. The butterfly valve is mounted on a shaft one end of which is connected to a lever 50. The butterfly valve is operated by a pneumatic ram 51 connected to the lever 50. The ram 51 is connected through pipe work (not shown) to a source of compressed air through a second conventional electrically actuated shut-off valve.

The bag opening head 49 comprises a nozzle 52 connected to a source of compressed air through pipe work (not shown). Yet another conventional electrically actuated shut-off valve in the pipe work controls the supply of air to the nozzle 52. The nozzle 52 is mounted in the lower end of an upwardly inclined open ended sleeve 53. The assembly functions as a venturi; i.e. when air emerges from the nozzle 52 it draws further air through the lower end of the sleeve. The shut-off valve is closed until, following the arrival of the leading edge of the tube T at the proximity sensor 46, the heat sealing and cut-off mechanism 15 and the vacuum head have been actuated as described above. The air emerging from the upper end of the sleeve 53 is directed at the leading edge and lifts the upper layer of film at the mouth of what is now a bag in the tube T away from the lower layer. The

mouth of the bag is thus automatically opened.

A bracket 72 carrying rollers 74 is mounted on the plate 70. The rollers run on a track 54 in the form of a stainless steel pipe located under the belts 17. By this means the assembly 16 can be readily moved to any position on the track corresponding to the length of bag required. The plate 70 is provided with a handle portion 55 which projects through a slot in the frame 11 for this purpose. Also provided is a brake 76 which bears on the track for locking the plate 70 in position. The brake is mounted on an L-shaped lever 78 which is pivoted to the handle 55. A tension spring connected to the lever urges the brake into contact with the track. The brake is released by lifting the portion 78a of the lever which is located under the handle 55.

The proximity sensor 46 is of conventional light actuated type and is located between the vacuum head and the bag opening head. It could also be located inside the vacuum head. Through electronic circuitry which includes a timing device and a kick operated master control switch indicated schematically at 56 it is interconnected to the various mechanisms described above. These mechanisms are electronically controlled and their sequence of operation will now be described.

The bag opening head 49 is first moved to a desired position on the track 54. It is assumed that a new roll 13 of film is mounted on the spindle 21. When the apparatus is switched on the vacuum pump 48, drive rolls 24, 25 and belts 17 will not be started until the kick switch 56 is actuated. The roll 24 is raised and the tube T is initially drawn off the roll by hand and fed through the drive rolls 24, 25. The roll 24 is lowered and clamped in position. The operator stands at the end of the apparatus opposite the tube feed end and actuates the kick switch 56. This starts the drive rolls and the belts 17. The tube T is fed by the rolls through the space 45 and along the belts 17. When the proximity sensor senses the arrival of the leading edge of the tube T the drive roller mechanism is stopped and the vacuum pump is switched on. The heat sealing and cut-off mechanism is actuated to form a bag. The butterfly valve controlling the vacuum head 47 is opened and the lower layer of film in the bag is sucked against the nozzle of the vacuum head 47. Momentarily thereafter the shut-off valve for the nozzle 52 of the bag opening head is opened, causing the mouth of the bag to be opened by the ensuing air blast. The joint of meat (or other article to be packaged) is placed in the bag. This is assisted by the downward slope of the belts. The bagged joint of meat is removed and the cycle is started again by actuating the kick switch.

The tube T may sometimes adhere to the clamping bar 40 above the nichrome wire. It must

then be detached in order to ensure that the tube advances properly. For this purpose the drive rolls are momentarily reversed after the cut off operation. The tube is thus pulled back a distance of perhaps 1 cm, ensuring that it is detached from the clamping bar 40. It is then advanced again until the leading edge reaches the proximity sensor as already described.

It may be advantageous to provide a vacuum tank and means to operate the vacuum pump automatically to maintain a constant vacuum in the tank. The vacuum at the head may then be controlled simply by operating the butterfly valve.

A modified arrangement for the drive rolls is shown in Figure 6. In this case the drive rolls 24', 25' are substantially similar those already described as is the mechanism for driving them. However, a pair of drums 80, 81 is mounted on the frame between the drive rolls and the plate 42. Endless belts 82 are mounted between the roll 24' and the drum 80 and also between the roll 25' and the drum 81. The rolls and drums are positioned so that there is a substantially flat gap 83 between the upper and lower sets of belts which gap is substantially coplanar with the upper face 43 of the plate 42. By this means the tube T is accurately guided over the face 43 and onto the moving surface S.

The modified apparatus 10' shown in Figures 7 and 8 includes a loading device 100 which is of assistance in loading a joint of meat (particularly a heavy joint such as a large cut of beef) into a bag. The loading device comprises a rack consisting of four mutually parallel polished stainless steel rods 102 cantilevered from a bar 103. The bar comprises a horizontal centre portion 104 and outer portions 105 which project angularly upwardly from each end of the centre portion. The inner two rods join the bar at the ends of the centre portion and the outer rods join the bar at the ends of the outer portions. The outer rods are thus mounted at a higher level than the inner rods. A joint of meat which slides along the rods thus tends to be cradled centrally on the rack.

The loading device further comprises a mounting bracket which is mounted on the end of the frame 11' of the apparatus 10'. The bracket includes a horizontally disposed arm 106. A vertically disposed spigot 107 depends from the bar 103 and is pivotably mounted in the outer end of the arm 106. The rack is thus capable of swivelling about a vertical axis. In the position shown in the drawing the rack is disposed so that the rods project towards the open mouth of a bag B which has been formed on the apparatus 10'. This facilitates the loading of a joint of meat from the rack into the bag. The rack can however be swivelled to a loading position (shown in dotted outline at 108) in which the rods are aligned with a conveyor (not

shown) which feed joints of meat to the machine. The loading of joints of meat from the conveyor onto the rack is thus facilitated.

Referring again to Figures 7 and 8, a pair of plates 120 is provided at the top of the frame with a longitudinally disposed slot 122 therebetween. The belts 17' are mounted above the plates. A pneumatic ram 90 is mounted on the frame 11' below the plates 120 with its axis parallel to slot 122. The ram is preferably of the so called "rod-less cylinder" type having a carriage 91 which runs along the body 92 of the ram. A suitable ram is model MYC25G700 supplied by SMC Corp of Tokyo, Japan. A vacuum head 47' is mounted on the carriage. The vacuum head projects through the slot 122. It may be noted that the bag opening head 49' is mounted on the arm 107.

Actuation of the ram 90 adjusts the position of the vacuum head. However, the provision of the ram enables the apparatus 10' to be operated in a way which is very convenient for the operator particularly where the apparatus will be handling joints of meat of a limited range of sizes. The positioning of the ram (and therefore of the vacuum head) can be determined by microswitches. In this example two such microswitches 94, 95 are used but more could be provided. They are fixed to handles 96, 97 which are slidably mounted on a rail 98 under the ram. The position of the microswitch 94 determines the length of a short bag and the position of the microswitch 95 determines the length of a long bag. The microswitches are actuated by a trigger 99 mounted on the carriage 92. A kick switch 56' is operated for making a short bag and a separate kick switch 56'' is provided for making a long bag. Operation of the kickswitch 56' disengages the microswitch 95 and operation of the kickswitch 56'' disengages the microswitch 94.

At the start of a cycle the carriage (as will become clear) is fully advanced and the vacuum head is at the extreme end of its travel (to the right in Figure 8). When, say, the kickswitch 56' is operated, the carriage retracts until the trigger 99 actuates the microswitch 94. This causes the drive rollers to feed the tube until its leading edge is sensed by the sensor 46'. The vacuum head and the heat sealing and cut-off mechanisms are activated to form a short bag B. Momentarily thereafter the bag opening head 49' is activated and the carriage 91 is advanced. The bag B is thus carried towards the loading device 100 while it is being opened. The bag and the air issuing from the head 49' are moving in opposite directions, assisting the opening of the bag. The rods 102 are positioned so that, when the head 47' reaches the limit of its travel to the right, the ends of the rods project into the open end of the bag. The bag is drawn by hand over the cut of meat on the rack. The rack is

then swivelled so that the rack is located over a removal conveyor onto which the bagged cut of meat is discharged.

The cycle can be repeated from this point by again operating the kickswitch 56'. If, alternatively, the kickswitch 56'' is operated, the machine will make a long bag. The bag lengths can be altered by repositioning the microswitches.

The vacuum head 47' incorporates a perforated grid (which can be seen in Figure 8) to increase the effective area of the nozzle against which the lower layer of the tube is sucked. The proximity sensor 46' is incorporated in the vacuum head.

Either apparatus 10, 10' may be provided with various additional features to increase its utility. For example it is likely that at least one device will be required to reduce or eliminate static electricity which occurs in the tube T. Such devices are known and do not need to be described in detail. One such device is shown schematically at 110.

Either apparatus 10, 10' can be designed so that it can be used (a) to make open-ended tubular packages; (b) to make unopened bags or packages; and (c) to produce bags or packages uninterruptedly. These respective functions can be achieved by incorporating in the control circuitry switches or the like which disengage the heat sealing ribbon 44; the bag opening head 47, 47'; and which by-pass the kickswitches 56, 56', 56''. There may be sufficient demand for an apparatus which produces unopened bags or open ended packages to justify (for price reasons) omission of the tube opening mechanism or the heat sealing mechanism.

A printing device may be mounted at a suitable location such as between the spindle assembly 12 and the drive roller assembly 14. Suitable printing devices are known per se, one such being sold under the name DATO/PACK™ marketed by Image Jet Printing Pte Ltd of Singapore. Another feature which may be provided is a counting device to count the number of bags produced by the apparatus and/or the length of tubular film used from each roll. Counting devices of this kind are also known per se.

The belts shown in the apparatus 10 are flat. The belts 17' shown in the apparatus 10' are of round cross section.

The apparatus is suitable for packaging meat in shrink-type packaging.

The apparatus can be used to form a package which is open at both ends. In this case the heat sealing mechanism can be inactivated or dispensed with.

It is not intended that the scope of a patent granted in pursuance of the application of which this specification forms a part should exclude modifications and/or improvements to the embodiments

described and/or illustrated which are within the scope of the invention as defined in the claims or be limited by details of such embodiments further than is necessary to distinguish the invention from the prior art.

### Claims

1. Apparatus of the kind used to produce packages from a stock of flexible laminar packaging material in the form of an elongate tube [T] in a packaging operation in which articles are packaged as the packages are made, the apparatus comprising tube feed means [14] and tube cut-off means [16] which can be operated to produce said packages by successively feeding leading portions of the tube off the stock and separating said leading portions from the stock, CHARACTERISED IN THAT the apparatus includes control means [46, 56, 70-78, 46', 90, 94-95, 56'-56''] for controlling the operation of the tube feed means which control means can be readily adjusted so as to cause the tube feed means to vary the length of each said leading portion as it is produced to suit the length of each article to be packaged.
2. Apparatus according to claim 1, CHARACTERISED IN THAT the control means includes a carriage [70, 47'] and means for positioning the carriage at a variable distance from the tube feed means, detecting means [46, 46'] mountable on the carriage and providing a signal upon detecting the arrival of a said leading portion at the carriage, and disabling means arranged in response to said signal to interrupt the operation of the tube feed means.
3. Apparatus according to claim 1 or claim 2, CHARACTERISED IN THAT the control means includes an operator activated switch [56, 56'-56''] for starting the operation of the tube feed means.
4. Apparatus according to claim 2 or claim 3, CHARACTERISED IN THAT the carriage is movably mounted on a track [54] and the means for positioning the carriage comprises operator releasable brake means [76-78] for holding the carriage in position on the track.
5. Apparatus according to claim 2 or claim 3, CHARACTERISED IN THAT the means for positioning the carriage comprises a ram [90] to which the carriage is connected, and the control means positions the carriage by extending or retracting the ram.

6. Apparatus according to any one of claims 2 to 5, CHARACTERISED IN THAT at least two endless belts [17, 17'] are provided which collectively provide a moving surface [S] on which said leading portions of the tube are supported as they move towards the carriage.
7. Apparatus according to any one of claims 2 to 6, CHARACTERISED IN THAT the carriage comprises a suction device [47, 47'] arranged to apply suction to a first layer of a said leading portion of the tube, and means to separate a second layer thereof from the first layer.
8. Apparatus according to any one of claims 1 to 7, CHARACTERISED IN THAT heat sealing means [44] is provided adjacent the cut-off means for sealing a rear edge of the leading portion of the tube.
9. Apparatus according to any one of claims 1 to 8, CHARACTERISED IN THAT the tube feed means comprises a pair of rolls [24-25, 24'-25'] which feed the tube past the cut-off means, and means for momentarily reversing the rolls after actuation of the cut-off means so that a forward edge of the stock formed by actuation of the cut-off means is drawn back from the cut-off means before being fed forward past the cut off means.
10. A method of producing packages from a stock of flexible laminar packaging material in the form of an elongate tube [T] for a packaging operation in which the articles are packaged as the packages are made, the apparatus comprising tube feed means [14] and tube cut-off means [33] which can be operated to produce said packages by successively feeding leading portions of the tube off the stock and separating said leading portions from the stock, CHARACTERISED IN THAT the method includes the steps of providing control means [46, 56, 70-78, 46', 90, 94-95, 56'-56''] for controlling the operation of the tube feed means, which control means are readily adjustable to cause the tube feed means to vary the lengths of said leading portions as they are produced to suit the length of each article to be packaged.

### Patentansprüche

1. Ein Gerät das in jener Art verwendet wird um Verpackungen aus einem Vorrat von flexiblem laminar Verpackungsmaterial in Form eines verlängerten Films (T) in einer Verpackungs-

operation herzustellen, in der Artikel verpackt werden können sowie sie hergestellt werden, indem das Gerät aus einer filmeinführenden Vorrichtung besteht (14) und einer Filmabschneidevorrichtung (16) die so betrieben werden kann, daß die besagte Verpackungen hergestellt werden indem nacheinander der vordere Abschnitt des Films vom Vorrat eingeführt wird, und dann der besagte vordere Abschnitt vom Vorrat abgetrennt wird, dadurch gekennzeichnet, daß das Gerät eine Kontrollvorrichtung (46, 56, 70-78, 46', 90, 94-95, 56'-56'') aufweist, um den Vorgang der filmeinführenden Vorrichtung zu kontrollieren, dessen Kontrollvorrichtung einfach verstellbar ist und somit die filmeinführende Vorrichtung dazu veranlaßt, die Länge eines jeden besagten vorderen Abschnitts zu variieren, so daß es so hergestellt ist, um der Länge des zu verpackenden Artikels zu entsprechen.

2. Ein Gerät gemäß Anspruch 1, dadurch gekennzeichnet, daß die Kontrollvorrichtung ein Beförderungsmittel (70, 47) und eine Vorrichtung aufweist, die das Beförderungsmittel in Position bringt, mit einem regulierbaren Abstand zur filmeinführenden Vorrichtung, einer Wahrnehmungsvorrichtung (46, 46') die auf dem Beförderungsmittel montiert ist, welche mit einem Signal versehen ist, das nach Feststellung der Ankunft des besagten vorderen Abschnitts an dem Beförderungsmittel, und eine betriebsstoppende Vorrichtung, die so eingerichtet ist, daß sie dem besagten Signal entspricht, um die Operation der filmeinführenden Vorrichtung zu unterbrechen.
3. Ein Gerät gemäß Anspruch 1 oder Anspruch 2, dadurch gekennzeichnet, daß die Kontrollvorrichtung einen von einem Bediener betätigten Schalter (56, 56'-56'') aufweist um die Operation der filmeinführenden Vorrichtung auszulösen.
4. Ein Gerät gemäß Anspruch 2 oder Anspruch 3, dadurch gekennzeichnet, daß das Beförderungsmittel beweglich auf die Schiene (54) montiert ist, und die Vorrichtung die das Beförderungsmittel in Position bringt, besteht aus einer von einem Bediener ausgelösten Bremsvorrichtung (76-78) die das Beförderungsmittel auf der Schiene in Position hält.
5. Ein Gerät gemäß Anspruch 2 oder Anspruch 3, dadurch gekennzeichnet, daß die Vorrichtung die das Beförderungsmittel in Position bringt, aus einem Stoßheber (90) besteht mit dem das Beförderungsmittel verbunden ist, und der

Kontrollvorrichtung die das Beförderungsmittel in Position bringt indem sie den Stoßheber vor- oder zurückschiebt.

- 5 6. Ein Gerät gemäß einem der Ansprüche 2 bis 5, dadurch gekennzeichnet, daß es mit mindestens zwei Endlosbändern (17, 17') ausgestattet ist die gemeinsam eine bewegliche Oberfläche (S) darstellen, auf der die besagten vorderen Abschnitte des Films gestützt werden sowie sie sich auf das Beförderungsmittel zubewegen.
- 10 7. Ein Gerät gemäß einem der Ansprüche 2 bis 6, dadurch gekennzeichnet, daß das Beförderungsmittel mit einem Ansaugergerät (47, 47') ausgestattet ist das so angebracht ist, daß es eine Saugwirkung auf die erste Schicht des besagten vorderen Filmabschnitts ausübt, und somit eine Vorrichtung darstellt, die eine zweite Schicht von der ersten trennt.
- 15 8. Ein Gerät gemäß einem der Ansprüche 1 bis 7, dadurch gekennzeichnet, daß es mit einer Hitzschweißvorrichtung (44) neben der Abschneidevorrichtung ausgestattet ist, das die hintere Kante des vorderen Filmabschnitts verschweißt.
- 20 9. Ein Gerät gemäß einem der Ansprüche 1 bis 8, dadurch gekennzeichnet, daß die filmeinführende Vorrichtung zwei Rollen aufweist (24-25, 24'-25') die den Film an der Abschneidevorrichtung und einer Vorrichtung die zusehends die Rollen rückwärts laufen läßt nachdem die Abschneidevorrichtung aktiviert wurde, vorbeiführt, so daß die nach vorne zeigende Kante des Vorrats die durch die Aktivierung der Abschneidevorrichtung gebildet wurde, sich von der Abschneidevorrichtung zurücksieht, bevor sie vorwärts, an der Abschneidevorrichtung vorbeigeführt werden kann.
- 25 10. Eine Methode zur Herstellung von Verpackungen aus einem Vorrat von flexiblem laminares Verpackungsmaterial in Form eines verlängerten Films (T) für eine Verpackungsoperation in der die Artikel verpackt werden können, sowie sie hergestellt werden, indem das Gerät aus einer filmeinführenden Vorrichtung besteht (14) und einer Filmabschneidevorrichtung (33) die so betrieben werden kann, daß die besagte Verpackungen hergestellt werden indem nacheinander der vordere Abschnitt des Films vom Vorrat eingeführt wird, und dann der besagte vordere Abschnitt vom Vorrat abgetrennt wird, dadurch gekennzeichnet, daß das Gerät eine Kontrollvorrichtung (46, 56, 70-78, 46', 90, 94-
- 30
- 35
- 40
- 45
- 50
- 55

95, 56'-56'') aufweist, um den Vorgang der filmeinführenden Vorrichtung zu kontrollieren, dessen Kontrollvorrichtung einfach verstellbar ist, und somit die filmeinführende Vorrichtung dazu veranlaßt, die Länge eines jeden besagten vorderen Abschnitts zu variieren, so daß es so hergestellt ist, um der Länge des zu verpackenden Artikels zu entsprechen.

### Revendications

1. Appareil du type utilisé pour réaliser des emballages à partir d'un stock de matériau laminaire souple sous forme d'un tube allongé (T') dans un procédé d'emballage suivant lequel les articles à emballer sont empaquetés au fur et à mesure que les emballages se forment, l'appareil comprenant un moyen d'avance du tube (14) et un moyen de coupure du tube (16) qui peuvent être actionnés pour créer lesdits emballages en effectuant successivement les opérations de faire avancer des tranches de tête du tube prises dans le stock, et de les séparer de celui-ci, CARACTERISE en ce que l'appareil comporte un moyen de commande (46, 56, 70-78, 46', 90, 94-95, 56'-56'') permettant de commander le fonctionnement du moyen d'avance du tube, ce moyen de commande étant facilement réglable pour que le moyen d'avance du tube fasse varier la longueur de chaque tranche de tête en fonction de la longueur de l'article à emballer.
2. Appareil selon la revendication 1, CARACTERISE en ce que le moyen de commande comprend un chariot (70, 47') et un moyen de positionnement du chariot en un point variable par rapport au moyen d'avance du tube; un moyen de détection (46, 46') pouvant se monter sur le chariot pour émettre un signal dès détection de l'arrivée au chariot d'une tranche de tête; ainsi qu'un moyen d'intervention prévu pour se mettre en marche en réponse audit signal et faire arrêter la marche du moyen d'avance du tube.
3. Appareil selon la revendication 1 ou la revendication 2, CARACTERISE en ce que le moyen de commande comprend un commutateur (56, 56'-56'') actionné par un opérateur pour mettre en marche le moyen d'avance du tube.
4. Appareil selon la revendication 2 ou la revendication 3, CARACTERISE en ce que le chariot se monte de façon mobile sur une piste (54) et que le moyen de positionnement du chariot est équipé d'un moyen de freinage (76 - 78) déclenchable par un opérateur pour immobiliser

le chariot sur la piste.

5. Appareil selon la revendication 2 ou la revendication 3, CARACTERISE en ce que le moyen de positionnement du chariot est équipé d'un bélière (90) auquel le chariot est relié et que le moyen de commande localise le chariot en prolongeant ou rentrant le bélière.
6. Appareil selon l'une quelconque des revendications 2 à 5, CARACTERISE en ce qu'au moins deux courroies sans fin (17-17') sont prévues, assurant ensemble une surface mobile (S) d'appui auxdites tranches de tête du tube lors de leur déplacement vers le chariot.
7. Appareil selon l'une quelconque des revendications 2 à 6, CARACTERISE en ce que le chariot est muni d'un dispositif d'aspiration (47, 47') prévu pour aspirer une première couche d'une tranche de tête du tube, ainsi qu'un moyen de séparation d'une deuxième couche de celle-ci de la première couche.
8. Appareil selon l'une quelconque des revendications 1 à 7, CARACTERISE en ce qu'il est prévu au voisinage du moyen de coupure un dispositif de fermeture thermique (44) destiné à fermer le bord arrière de la tranche de tête du tube.
9. Appareil selon l'une quelconque des revendications 1 à 8, CARACTERISE en ce que le moyen d'avance du tube comprend une paire de rouleaux (24-25, 24'-25'), qui font avancer le tube au-delà du moyen de coupure, ainsi qu'un moyen de faire inverser le sens des rouleaux, de sorte qu'un bord avant du stock formé par l'actionnement du moyen de coupure se retire devant le moyen de coupure avant de s'avancer pour passer au-delà du moyen de coupure.
10. Méthode de réalisation des emballages à partir d'un stock de matériau laminaire souple sous forme d'un tube allongé (T) pour un procédé d'emballage suivant lequel les articles à emballer sont empaquetés au fur et à mesure que les emballages se forment, l'appareil comprenant un moyen d'avance du tube (14) et un moyen de coupure du tube (33) qui peuvent être actionnés pour créer lesdits emballages en effectuant successivement les opérations de faire avancer des tranches de tête du tube prises dans le stock et de les séparer de celui-ci, CARACTERISE en ce que la méthode comporte un moyen de commande (46, 56, 70-78, 46', 90, 94-95, 56'-56'') permettant de com-

mander le fonctionnement du moyen d'avance  
du tube, ce moyen de commande étant facile-  
ment réglable pour que le moyen d'avance du  
tube fasse varier la longueur de chaque tran-  
che de tête en fonction de la longueur de 5  
l'article à emballer.

10

15

20

25

30

35

40

45

50

55

10



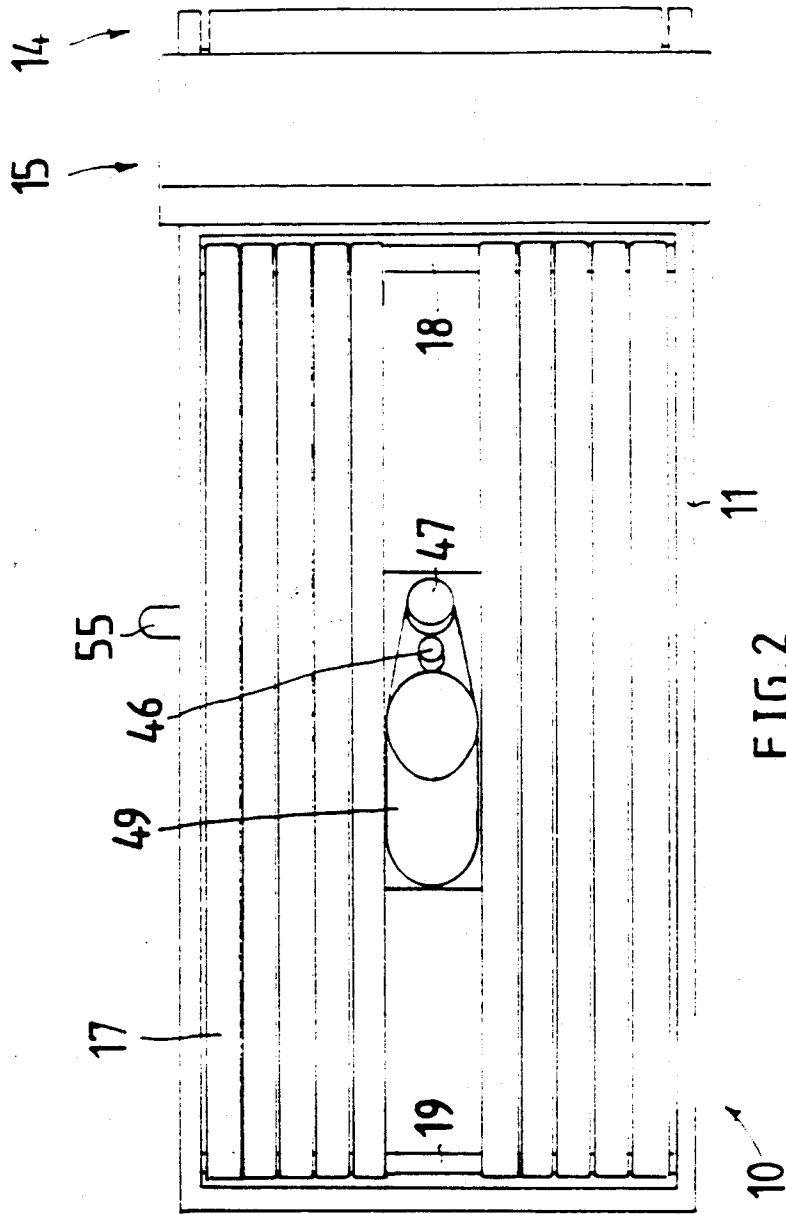

FIG. 2

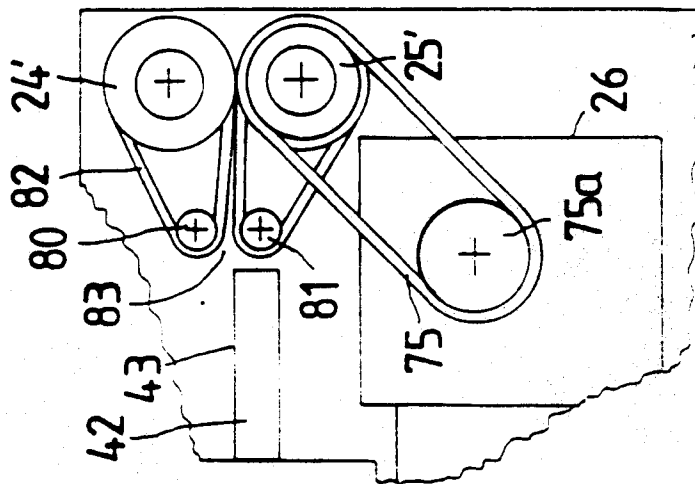

FIG. 6

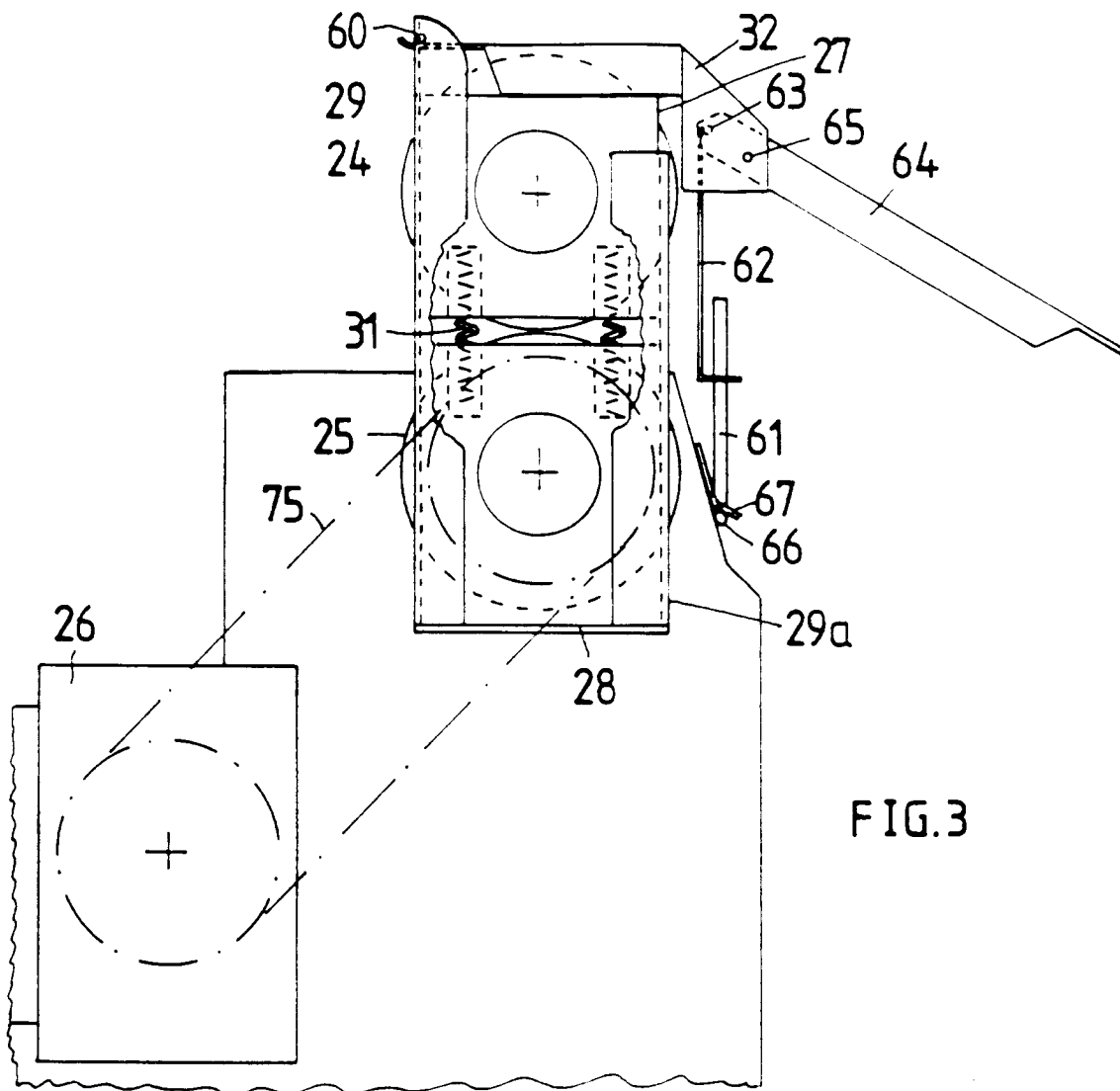

FIG. 3

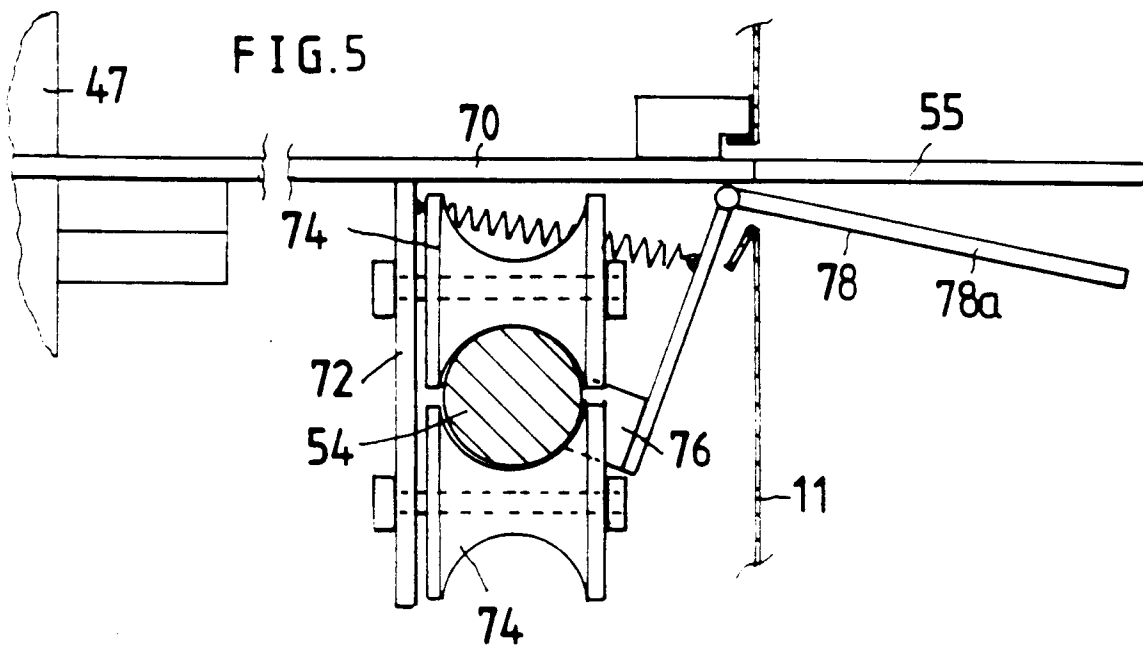

FIG. 5

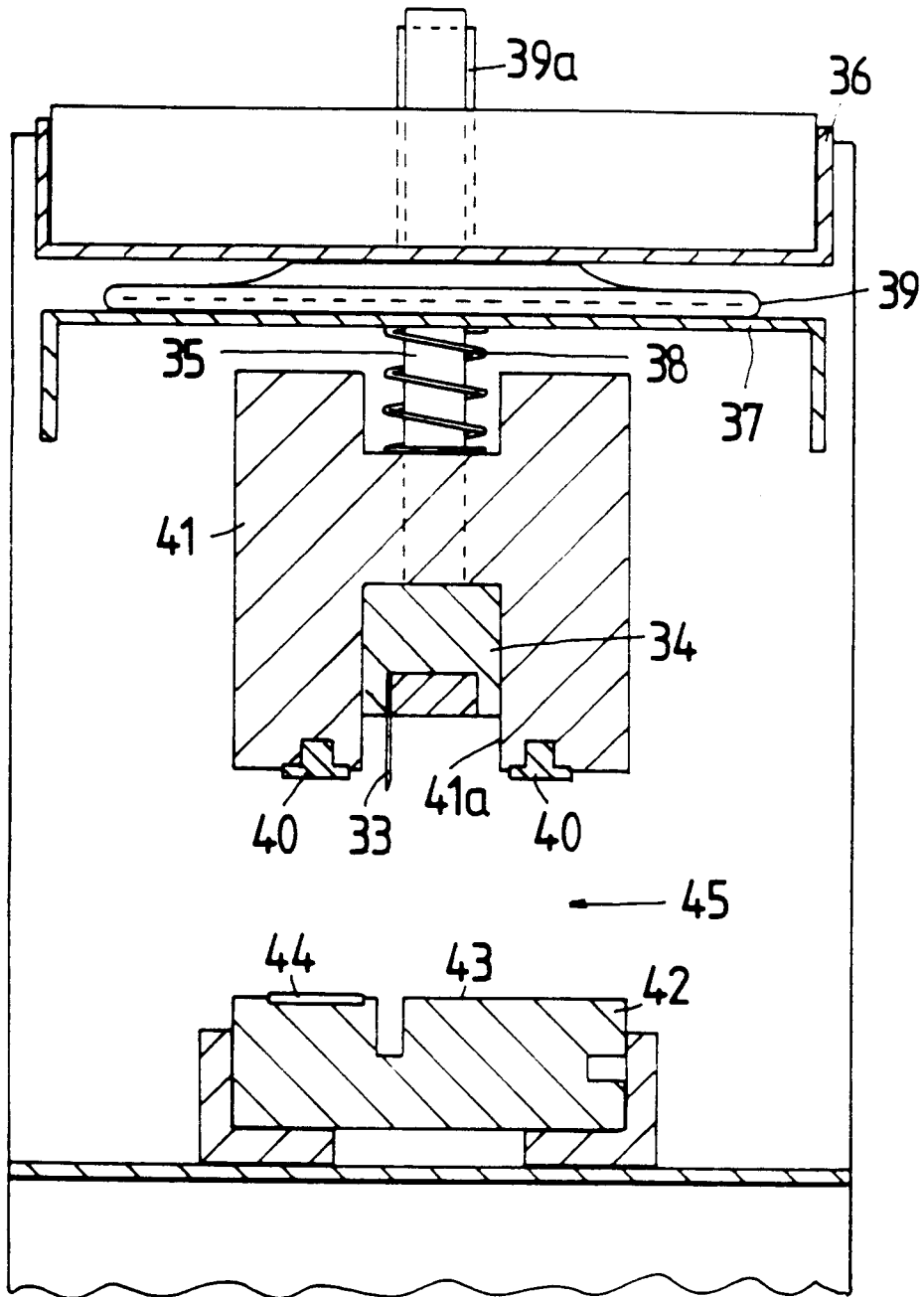

FIG. 4

