

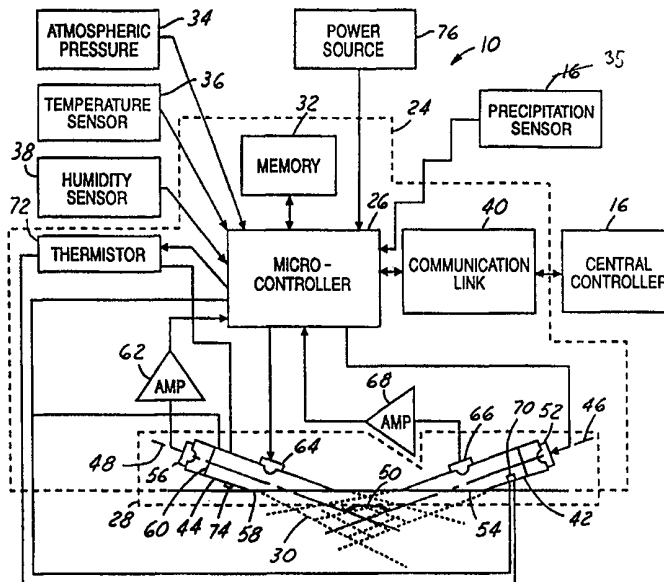

INTERNATIONAL APPLICATION PUBLISHED UNDER THE PATENT COOPERATION TREATY (PCT)

| | | |
|---|--|---|
| <p>(51) International Patent Classification ⁶ : B60Q 1/02, G08B 21/00</p> | <p>A1</p> | <p>(11) International Publication Number: WO 99/50092 (43) International Publication Date: 7 October 1999 (07.10.99)</p> |
| <p>(21) International Application Number: PCT/US99/07135 (22) International Filing Date: 31 March 1999 (31.03.99) (30) Priority Data: 09/053,034 1 April 1998 (01.04.98) US 09/196,362 19 November 1998 (19.11.98) US 60/115,140 8 January 1999 (08.01.99) US (71) Applicant: SENTEC CORPORATION [US/US]; Suite 205, 2000 Oakley Park Road, Walled Lake, MI 48390 (US). (72) Inventors: SAWATARI, Takeo; 6105 Gilbert Lake Road, Bloomfield Hills, MI 48301 (US). GAUBIS, Philip, A.; 235 Wabasso Street, Walled Lake, MI 48390 (US). CHARNETSKI, Clark, J.; 2646 Traver Boulevard, Ann Arbor, MI 48105 (US). (74) Agent: REES, John, W.; Dykema Gossett PLLC, Suite 300, 1577 North Woodward Avenue, Bloomfield Hills, MI 48304-2820 (US).</p> | <p>(81) Designated States: AL, AM, AT, AU, AZ, BA, BB, BG, BR, BY, CA, CH, CN, CU, CZ, DE, DK, EE, ES, FI, GB, GD, GE, GH, GM, HR, HU, ID, IL, IN, IS, JP, KE, KG, KP, KR, KZ, LC, LK, LR, LS, LT, LU, LV, MD, MG, MK, MN, MW, MX, NO, NZ, PL, PT, RO, RU, SD, SE, SG, SI, SK, SL, TJ, TM, TR, TT, UA, UG, UZ, VN, YU, ZW, ARIPO patent (GH, GM, KE, LS, MW, SD, SL, SZ, UG, ZW), Eurasian patent (AM, AZ, BY, KG, KZ, MD, RU, TJ, TM), European patent (AT, BE, CH, CY, DE, DK, ES, FI, FR, GB, GR, IE, IT, LU, MC, NL, PT, SE), OAPI patent (BF, BJ, CF, CG, CI, CM, GA, GN, GW, ML, MR, NE, SN, TD, TG).</p> <p>Published <i>With international search report.</i></p> | |

(54) Title: VISIBILITY SENSOR SYSTEM



(57) Abstract

A visibility sensor system (12) includes a housing (124) having a sensor head opening. A removable sensor head assembly (100) is removably coupled to the housing (124) within the sensor head opening. The sensor head assembly (100) has a sensor enclosure and a connector (132). An electronics module (126) is coupled to the sensor head (100) through the connector (132). A rain sensor (35) determines the presence of rain and causes shutters (122) to cover openings (54, 58) in the sensor enclosure. In other embodiments, an alternate sensor enclosure (226) is configured to develop a pressure differential internally to minimize contamination of light source (52) and light detector (56).

FOR THE PURPOSES OF INFORMATION ONLY

Codes used to identify States party to the PCT on the front pages of pamphlets publishing international applications under the PCT.

| | | | | | | | |
|----|--------------------------|----|--|----|--|----|--------------------------|
| AL | Albania | ES | Spain | LS | Lesotho | SI | Slovenia |
| AM | Armenia | FI | Finland | LT | Lithuania | SK | Slovakia |
| AT | Austria | FR | France | LU | Luxembourg | SN | Senegal |
| AU | Australia | GA | Gabon | LV | Latvia | SZ | Swaziland |
| AZ | Azerbaijan | GB | United Kingdom | MC | Monaco | TD | Chad |
| BA | Bosnia and Herzegovina | GE | Georgia | MD | Republic of Moldova | TG | Togo |
| BB | Barbados | GH | Ghana | MG | Madagascar | TJ | Tajikistan |
| BE | Belgium | GN | Guinea | MK | The former Yugoslav Republic of Macedonia | TM | Turkmenistan |
| BF | Burkina Faso | GR | Greece | | | TR | Turkey |
| BG | Bulgaria | HU | Hungary | ML | Mali | TT | Trinidad and Tobago |
| BJ | Benin | IE | Ireland | MN | Mongolia | UA | Ukraine |
| BR | Brazil | IL | Israel | MR | Mauritania | UG | Uganda |
| BY | Belarus | IS | Iceland | MW | Malawi | US | United States of America |
| CA | Canada | IT | Italy | MX | Mexico | UZ | Uzbekistan |
| CF | Central African Republic | JP | Japan | NE | Niger | VN | Viet Nam |
| CG | Congo | KE | Kenya | NL | Netherlands | YU | Yugoslavia |
| CH | Switzerland | KG | Kyrgyzstan | NO | Norway | ZW | Zimbabwe |
| CI | Côte d'Ivoire | KP | Democratic People's Republic of Korea | NZ | New Zealand | | |
| CM | Cameroon | | | PL | Poland | | |
| CN | China | KR | Republic of Korea | PT | Portugal | | |
| CU | Cuba | KZ | Kazakistan | RO | Romania | | |
| CZ | Czech Republic | LC | Saint Lucia | RU | Russian Federation | | |
| DE | Germany | LI | Liechtenstein | SD | Sudan | | |
| DK | Denmark | LK | Sri Lanka | SE | Sweden | | |
| EE | Estonia | LR | Liberia | SG | Singapore | | |

VISIBILITY SENSOR SYSTEM

BACKGROUND OF THE INVENTION

5 The present invention relates generally to a sensor system to detect visibility and, more specifically, to a visibility sensor system having a removable sensor head that may be removed for servicing.

 Reduced visibility on highways due to fog or blowing dust has often been the cause of tragic traffic accidents. Fog, especially in mountainous regions, has a tendency to build
10 up in patchy dense pockets. At highway speeds, in particular, a driver may suddenly find himself within one of these patchy dense fog pockets.

 The ability to adequately warn drivers of dense fog is highly desirable. If adequate warning is provided to drivers, drivers may then reduce their speed based on the density of the fog. Adequate warnings will reduce loss of life.

15 Several optical and non-optical methods for determining the presence of fog are known. Most, however, are not suitable for highway visibility sensors. There are several optical systems that may be used. Radar and lidar systems are used to gather general weather data. Such systems are too expensive, bulky, insensitive and difficult to use on a highway. Closed circuit television has limited use for visibility detection, but it cannot function at night and requires
20 monitoring by an operator. Airports commonly use transmissometers. Transmissometers measure the transmission of a light beam traveling a given path. Transmissometers are very expensive and require considerable maintenance and thus are not suitable to detect patchy highway fog. Coulter counters are often used in clean room monitoring. Coulter counters are very expensive and have high maintenance and power consumption requirements.

Non-optical devices such as triboelectric current sensors depend on the flow of gas rubbing against an electrode. Fog, however, frequently occurs in quiet atmospheric conditions. Spark discharge sensors require sensor electrodes to continually be kept clean and thus maintenance costs are prohibitive. A dosimeter-type particle density measurement device
5 does not provide real-time data.

Another optical device for measuring fog is a nephelometer. Known nephelometers have expensive optical systems and are very large in size. The optical system requires constant maintenance to clean the windows through which the optics are directed.

In particular, there are problems applying a nephelometer for activating a fog lamp
10 in a vehicle. Such nephelometers generally include a "window" through which light is transmitted and received. "Window" contamination in a nephelometer (i) makes accurate measurement of fog almost impossible; (ii) requires costly maintenance (constant cleaning); (iii) wipers to clean the "window" are not a solution; (iv) makes it difficult to calibrate even with an additional optical system; and (v) contributes to crosstalk through the "window" material. An
15 example of such a prior art device is disclosed in U.S. 5,349,267.

Another problem with nephelometers involves detector saturation due to "wrong" look direction. Yet another problem with a nephelometers involves airflow "turbulence" which causes measurement errors. Other methods for fog detection include: coulter counter, spark discharge, transmissometer, radar, lidar, CCTV, etc. These approaches, however, are expensive
20 and/or hard to install.

In certain situations, it may be desirable for the vehicle to have a visibility detection system associated therewith. It would likely be cost prohibitive to provide highway

visibility detection systems across the country. Therefore, it is desirable to provide a visibility sensor system associated with the vehicle.

On ships, it is difficult to determine visibility due to lack of background for comparison. For ships, it may also be desirable to locate a visibility sensor on the ship.

5 It would therefore be desirable to provide a visibility sensor system that overcomes the drawbacks of the prior art. Particularly, it would be desirable to provide a visibility sensor system that is inexpensive, has low maintenance, and is reliable to endure the conditions experienced on a highway.

10

SUMMARY OF THE INVENTION

It is therefore an object of the invention to provide an improved visibility detection system. More specifically, it is an object of the invention to provide a visibility detection system suitable for incorporation on an automotive vehicle.

15

According to one embodiment of the invention, a detector includes a housing having a first hollow opening and a second hollow opening. A first light source is fixed within the housing and directs light through the first hollow opening to a sample volume outside the housing. A first light detector receives light reflected from the sample volume through the second hollow opening. A controller is coupled to the first light source and the first detector.

20

The controller determines an output indicative of visibility from the light received by the first light detector.

In another embodiment of the visibility sensor system, a display may be coupled to the controller to warn drivers of the existence of fog ahead. The display may also indicate a safe driving speed through the fog.

In yet another embodiment of the invention, a means for compensating for the deterioration of the first detector may be included. To compensate for the deterioration of the first detector, a second light source may be placed adjacent to the first detector and illuminate the first detector with a predetermined amount of light. The controller then calculates the deterioration of the first detector in its visibility calculation. In another aspect of the invention, a means for determining deterioration of the first light source may be concluded. The means for compensating for deterioration of the first light source includes a second detector located adjacent to the first light source. The second detector would provide feedback to the controller as to the deterioration of the light source. The controller would then compensate for any deterioration of the first light source in its calculation for visibility.

In yet another embodiment of the invention, a method for detecting visibility comprises the steps of illuminating a sample volume of air from a first hollow opening within a housing using a first light source, detecting the amount of light scattering from the volume of air with a first detector that receives light through a second hollow opening and calculating a visibility factor based upon the light scattering from the fog particles in the volume of air.

In one aspect of the method for calculating visibility, the calculation may take into consideration deterioration of the first detector and the first light source.

In still another embodiment of the invention, a removable sensor head comprises a sensor enclosure defining a first optical port and a second optical port. A first circuit board is coupled to the sensor enclosure. A first connector is coupled to the first circuit board. A light

source is coupled to the first circuit board, which positions the light source within the first optical port. A second circuit board is coupled to the sensor enclosure. A second connector coupled to the second circuit board. A light detector is coupled to the second circuit board. The second circuit board positions the light detector within the second optical port. A calibration memory
5 is coupled to the second circuit board.

In a further embodiment of the invention, a visibility sensor assembly has a housing having a sensor head opening. A removable sensor head assembly is removably coupled to the housing within the sensor head opening. The sensor head assembly has a sensor enclosure and a connector. An electronics module is coupled to the sensor head through the connector.

10 In yet another embodiment, a rain sensor is provided, which is configured to close one or more shutters that cover the first and second openings. This has the advantage of minimizing the entry of contaminants.

In yet another embodiment, a sensor enclosure is provided which is configured to produce an airflow therethrough such that contaminants are swept through the enclosure. This
15 has the advantage of minimizing the contamination of the light source and/or light detector.

One advantage to providing a removable sensor head is that the maintenance costs are reduced because the sensor head may be easily replaced.

One advantage of the present invention is that it features a no window/no lens approach. That is, no optics or windows are required within the hollow openings through which
20 light is transmitted and received. This eliminates a major problem for optical sensor systems. That is, eliminating the persistent need for cleaning of the optics or windows, wherein such maintenance frequency may be reduced to less than $1/10$ that of existing nephelometers.

Another advantage of a fog sensor according to the invention involves synchronous detection for ambient light rejection.

Another advantage of the present invention is that short periodic onsite inspections for calibration are not required. The sensor system provides a means for compensating for the deterioration of a detector and light source. The sensor system also can
5 provide a self check and report the results to a central monitoring station.

Another advantage of the present invention is that a variety of communication options may be supported. For example, communication to a centrally located communication center may be provided via fiber optics, a cable, RF, telephone, and cellular phones.

10 Yet another advantage of the present invention is that the system operates using a significantly less amount of energy compared to that of other known fog detection systems. The sample rate for determining fog may be changed depending on whether the conditions around the sensor are changing to make fog more likely. If the conditions are such that fog is likely, the sample rate may be increased. Power use is thereby minimized.

15 Yet another advantage of the present invention is the compactness of the sensor system. A separate post does not need to be installed along the highway for a sensor system. The sensor system may be installed on currently existing posts such as speed limit signs or other highway signs. If used for a vehicle application, the package size and weight are small.

BRIEF DESCRIPTION OF THE DRAWINGS

Other features and advantages of the present invention will become apparent from the following detailed description which should be read in conjunction with the drawings in
5 which:

Figure 1 is a diagrammatic view of a highway warning system employing a visibility sensor according to the present invention;

Figure 2 is a diagrammatic of a visibility sensor head according to the present invention;

10 Figure 3 is a diagrammatic view of an alternative embodiment of a visibility sensor;

Figure 4 is a flow chart a method for operating a visibility sensor system to conserve energy;

15 Figure 5 is a partial cutaway elevational view of a removable sensor head according to the invention;

Figure 6 is a bottom view of the removable sensor head of Figure 5;

Figure 7 is a side elevational view of a removable sensor and electronic module mounted within a housing;

Figure 8 is a bottom view of the visibility sensor system of Figure 7;

20 Figure 9 is a forward looking elevational view of an external rear view mirror housing of a car having a visibility detection system located therein;

Figure 10 is a top elevational view of the rear view mirror housing with visibility detection system of Figure 9;

Figure 11 is a side view of an automotive vehicle having a visibility detection system mounted thereto;

Figure 12 is a side view of an automotive vehicle having a visibility detection system mounted in an alternative manner to that of Figure 11;

5 Figure 13 is a cross-sectional view of an alternative sensor head housing;

Figure 14 is a side cross-sectional view similar to that of Figure 13 having sensor located in a different orientation;

Figure 15 is a timing diagram view illustrating a synchronous detection feature to identify precipitation according to the invention;

10 Figure 16 is a simplified, perspective view of a vehicle having a visibility sensor/fog lamp combination embodiment according to the invention;

Figure 17 is a simplified front view of a preferred visibility sensor/fog lamp combination embodiment according to the present invention;

15 Figure 18 is a side view, partially in section, of the embodiment shown in Figure 17;

Figure 19 is a simplified front view of an alternate, preferred visibility sensor/fog lamp combination embodiment in accordance with the present invention;

Figure 20 is a simplified side view, partially in section, of the embodiment shown in Figure 19;

20 Figure 21 is a simplified bottom view of yet another preferred visibility sensor/fog lamp combination embodiment in accordance with the present invention;

Figure 22 is a simplified side view, partially in section, of the embodiment shown in Figure 21;

Figure 23 is a simplified front view of still yet another preferred, visibility sensor/fog lamp combination embodiment in accordance with the present invention;

Figure 24 is a simplified side view, partially in section, of the embodiment illustrated in Figure 23;

5 Figures 25-26 are bottom and side views, respectively, of still yet another visibility sensor/fog lamp embodiment according to the present invention;

Figure 27 is a simplified side view of a visibility sensor/fog lamp as installed in a front bumper; and

10 Figure 28 is an enlarged, partial side view showing a removable sensor enclosure feature of one embodiment.

DETAILED DESCRIPTION OF THE PREFERRED EMBODIMENT

Referring now to the drawings, like reference numerals are used to identify
15 identical components in the various views. Although the invention will be illustrated in terms of a fog detection visibility sensor, it will be appreciated that this invention may be used with other visibility applications such as detection of blowing dust. In addition the visibility sensor may be used for remote weather stations, airports and in maritime applications such as near a lighthouse.

20 Referring now to Figure 1, a highway visibility detection system 10 has a visibility sensor unit 12, a warning display 14 and a central controller 16. Visibility sensor unit 12 is preferably placed at eye level of a vehicle operator 18 in an automotive vehicle 20. Visibility sensor unit 12, warning display 14 and central controller 16 may all be linked through

a communications network. A communication network, for example, may be cellular phone, RF, cable, or optical fiber. As shown, each of visibility sensor unit 12, warning display 14 and central controller 16 has an antenna 22 which may be used for RF or cellular communication between each.

5 Upon detection of reduced visibility by visibility sensor unit 12, an indication as to the distance of visibility may be displayed on warning display 14. Also, a suggested vehicle speed may also be displayed on warning display 14.

 Central controller 16 may be part of an intelligent transportation system (ITS). The central controller 16 may be a manned controller which may perform a number of functions
10 such as initiating self-tests for the sensor unit 12 or sending a maintenance crew to service the sensor in the event of contamination.

 Referring now to Figure 2, visibility sensor unit 12 preferably has most of its components sealed within a housing 24. Several visibility sensor units may be coupled within one housing 24. The operation of the system is generally controlled by a micro controller 26.
15 A sensor head 28 is coupled to and controlled by micro controller 26. Sensor head 28 transmits light to a sample volume 30 and provides micro controller 26 an indication of the amount of light reflected from fog particles in a sample volume 30 below sensor head 28. A memory 32 is used to store various information and is coupled to micro controller 26. Memory 32 is preferably nonvolatile memory. Memory 32, for example, may contain a conversion factor for converting
20 the amount of light received by sensor head 28 to a visibility distance. Memory 32 may also store service and calibration data, security codes, the serial number of the system, and visibility data history.

Various sensors for sensing the atmospheric conditions around the housing 24 of visibility sensor system 12 are coupled to micro controller 26. Such sensors may include an atmosphere pressure sensor 34, one or more precipitation sensors 35, a temperature sensor 36 and a humidity sensor 38.

5 Micro controller 26 may also be coupled to a communications link 40 that allows micro controller 26 to communicate with a central controller 16. Although atmospheric pressure sensor 34 has been shown coupled directly to micro controller 26, atmospheric pressure sensor 34 may be coupled directly to central controller 16. In such a case, atmospheric pressure data would be provided through communications link 40 to micro controller 26. Micro controller 26
10 may be used to calculate the safe speed based upon the visibility detected by the sensor head 28. The calculation of a safe speed may be done at a central controller.

Communications link 40 may be one of a number of types of communications links that may be used to link micro controller 26 to central controller 16. Because the detector system may be used in a variety of locations and conditions, flexibility for various types of
15 communications is required. Communications link 40 may, for example, be cellular telephone link, an RF link, a fixed cable link, or optical fiber link. Communications link 40 may be used to couple to a warning display (shown as 14 of Figure 1) on the highway.

Sensor head 28 has a first optical port 42 and a second optical port 44. First optical port 42 has a first optical axis 46 and second optical port 44 has a second optical axis 48.
20 First optical axis 46 coincides with the longitudinal axis of first optical port 42. Likewise, the second optical axis 48 coincides with the longitudinal axis of second optical port 44. An angle 50 between first optical axis 46 and second optical axis 48 may be about 150°.

In some applications the first optical port could coincide with the second optical port. In such a case, no the ports would share the same longitudinal axis.

Recessed within first optical port 42 is a first light source 52. First light source 52 is preferably mounted in an end of first optical port 42. First light source 52 is preferably an infrared light emitting diode having a relatively narrow beam width. First light source 52 may, for example, have a total beam width of 10° . Light from first light source 52 emerges from first optical port 42 at a first hollow opening 54. The cone of diverging light from first light source 52 illuminates a sample volume 30 outside first optical port 42.

Second optical port 44 has a first detector 56 located in an end thereof. First detector 56 is sensitive to the wave length of light scattered from the sample volume 30. First detector 56 may have a small surface area such as a five square millimeter surface area. Light is reflected from particles in sample volume 30 into a second hollow opening 58. A light filter 60 may be interposed in the optical path between sample volume 30 and first detector 56. Filter 60 is provided to filter ambient light from first detector 56. First detector 56 provides an output to micro controller 26 through a low noise amplifier 62 corresponding to the amount of light reflected from particles in sample volume 30.

In one constructed embodiment, both second optical port 44 and first optical port 42 were constructed of .5 inch diameter by 3.5 inch tube.

A test light source 64 may be provided in second optical port 44. Test light source 64 is also preferably an infrared LED. Test light source 64 preferably has a relatively wide beam width of approximately 80° so that light may be directed into second optical port 44 to first detector 56. Test light source 64 is coupled to micro controller 26. Micro controller 26 controls

the operation of test light source 64. Test light source 64 is used during self testing and self calibration as will be further described below.

A compensation detector 66 is coupled within first optical port 42. Compensation detector 66 may have a smaller area such as a 1.5 square millimeter detection area. Compensation detector 66 is coupled to micro controller 26 through a low noise amplifier 68, compensation detector 66 provides feedback to micro controller 26 as to the operation of first light source 52 during self test and self calibration.

A heater 70 is coupled adjacent to first light source 52 and first detector 56 to prevent condensation on the optical surfaces. Heater 70 may be a tungsten wire or thermoplastic element. Heater 70 may, for example, maintain a differential temperature of roughly 5° C between the optical surfaces and ambient temperature to prevent condensation. A thermistor 72 may be coupled adjacent to the heater 70 to provide feedback to micro controller 26 so that the functioning of heater 70 may be monitored.

An insect repellant 74 may be placed inside or adjacent to first optical port 42 and second optical port 44. Insect repellant 74 may be a variety of insect repellant means. Insect repellant may, for example, be a chemical known to be poisonous or repellant to the insects of the area into which the highway visibility detector system will be placed.

A power source 76 is used to power the highway visibility detection system 10. Highway visibility detection system 10 is flexible in the sense that it may operate from a variety of sources of power. Power source 76 may, for example, be a solar cell coupled to storage batteries. The power source may also be batteries or be coupled directly to a fixed power line.

Precipitation sensor 35 may comprise a conventional rain sensor or a conventional snow sensor. Such sensors are known, for example, as described in K. Mori, et al. "An

Intermittent Wiper System with a Raindrop Sensor,” SAE Technical Paper Series, SAE, September 23-26, 1985, hereby incorporated by reference.

Referring now to Figure 3, an alternative embodiment for first optical port 42 and second optical port 44 is shown. In this embodiment, first optical axis 46 and second optical axis
5 48 are not aligned with the longitudinal axis of first optical port 42 and second optical port 44. First optical axis 46 and second optical axis 48 also preferably have an angle of about 150° between them. The embodiment of Figure 3 operates in the same manner as that of Figure 2.

One method for operating a highway visibility detector system of the present invention would be to continuously operate the system so as to constantly provide feedback to
10 the central control and to a warning display or several displays. Operating a fog detection system continuously, however, is unnecessary and consumes power unnecessarily.

Referring now to Figure 4, based upon atmospheric conditions, the potential for fog can be predicted. From meteorology, a saturation surface, which is sometimes called the maximum vapor pressure surface, can be defined in three-dimensional space defined by
15 temperature, humidity and pressure or two dimensional surface defined by temperature and humidity. Fog occurs when the saturation surface is reached. In order to conserve energy, micro controller 26 performs the following operations. First the atmospheric pressure is measured in step 80. In step 82 the humidity is measured. In step 84 the temperature is measured. Each of the atmospheric pressure, humidity and temperature conditions are preferably measured outside
20 the housing of the highway visibility detector system. From the condition measured in steps 80 through 84, step 86 determines the distance from the saturation surface. In step 88, the distance from the saturation surface is compared with the previous distance from the saturation surface to determine the speed that the saturation surface is being approached. In step 90, the time to

reach the saturation surface is estimated. In step 92, the sample rate is changed so that the micro controller will turn on to determine visibility at a higher rate if the saturation surface is being approached. One method for setting the sample rate may be that if the estimated time to reach saturation is below 3 hours, then the micro controller will turn on at a rate twice as fast as the normal operation mode. For example, this faster rate may be twice an hour. As the estimated time goes lower, the sample rate can be further increased. By increasing the time of sample only when the saturation surface is being approached, energy is conserved. After executing step 92, step 80 is re-executed and the next sample period determined by the micro controller.

In this manner, the highway visibility detector system 10 does not operate needlessly. Thus, energy is conserved.

In operation, during visibility sampling, the first light source illuminates a sample volume 30 beneath housing 24. Fog or dust particles cause light to be scattered from the sample volume 30 into first detector 56. The amount of light scattered will be dependent upon the particle size and/or the number of particles of the contaminants within the sample volume 30. The light scattered from the sample volume has a direct correlation to the visibility present around the highway visibility detector. Data acquisition may be taken once or preferably sampled a number of times to statistically ensure satisfactory results. The received voltage level corresponding to the amount of illumination on the first detector 56 may be converted by a micro controller 26 into a visibility. Micro controller 26 may also convert the visibility into a safe speed for the roadway. The safe speed may be calculated or looked up in a table stored in memory 32.

The sensor system also has the ability to self calibrate. During manufacturing, a light scattering calibration object may be positioned in the sample volume. The micro

controller, when commanded, can save the measurement and determine a correction factor to be stored in the non-volatile memory. The correction factor will be used to correct subsequent visibility measurements. Calibration may easily be done at the manufacturer and easily confirmed when installed in the field.

5 Referring now to Figures 5 and 6, in certain implementations of the invention it may be desirable to have a sensor head 100 that is easily removable and replaceable. In such a manner, servicing time of the visibility sensor would be reduced. A sensor enclosure 102 defines first optical port 42 and second optical port 44. A center wall 104 separates first optical port 42 from second optical port 44. End pieces 106 and 108 of each port 42 and 44 opposite center wall
10 104 have end pieces 106 and 108 respectively. Each end piece 106 and 108 are respectively used to secure circuit boards 110 and 112 thereto. Sensor enclosure 102 of removable sensor head 100 has a bottom surface 120 that has first hollow opening 54 and second hollow opening 58 similar to that described above.

Circuit board 110 is also used to secure light source 52. Circuit board 110 may
15 also be used to secure a connector 113 which is used to supply power to light source 52. Connector 113 may be one of a variety of types of connectors including being a male or female end of a snap in or screw type connector. Connector 113 should allow easy connection and disconnection to facilitate removal of removable sensor head 100. A plurality of wires 117 may be used to couple light source 52 to a power source or microcontroller.

20 Circuit board 112 is secured to photo detector 56. Photo detector 56 is preferably coupled to infrared filter 60 as described above. Circuit board 112 preferably has an amplifier 62 mounted thereto. By mounting amplifier 62 to circuit board 112, noise transmission through connecting wire 118 is reduced. Circuit board 112 also preferably has a calibration memory 116

coupled thereto. Functionally, calibration memory 116 may be part of memory 32 shown in Figure 2. By locating calibration memory 116 on circuit board 112, the calibrations associated with the removable sensor head 100 are also removed. When a replacement sensor head 100 is coupled to the visibility sensor system, micro controller 26 uses the information stored in calibration memory 116 to generate the required results.

Commercially, photo detectors are often packaged together with an amplifier 62. A wire or a plurality of wires 118 are used to couple connector 114 to the remaining circuitry of the visibility sensor.

Referring now to Figure 6, first hollow opening 54 and second hollow opening 58 within bottom surface 120 are preferably oval in shape. The oval shape has been found to be beneficial in providing a high signal to noise ratio for the fog detection system, as well as providing the least signal deterioration due to contamination of the surface of first light source 52.

A shutter 122 shown on second hollow opening 58 may be used to cover second hollow opening 58 to prevent contamination of photo detector 56. Of course, a second shutter may also be incorporated in a similar manner over first hollow opening 54 to prevent contamination of light source 52. Shutter 122 is preferably a simple solenoid operated device. Shutter 122 may be switch operated, operated manually or automatically operated. One manner for automatically operating shutter 122 is to estimate the likelihood of fog with respect to the approachment of a saturation surface as described above. As the saturation surface is approached, shutter 122 may be opened. To prevent shutter 122 from opening in a car wash, the system may be coupled to a sensor in the transmission of the vehicle that senses whether the

vehicle is in neutral, park or the engine is stopped. Commonly vehicles are placed in neutral when being washed in a car wash. This prevents soap film from fouling the sensors.

To reiterate, one of the problems of conventional fog sensors for automotive applications involves keeping the sensor “window” surface clean. Most of the conventional sensor system attempts for an automotive application fail because of this problem. As described
5 above, and in accordance with the present invention, an inventive sensor enclosure configuration eliminates a sensor “window”, and further, optionally employs means, such as one or more shutters, for covering the “windowless” openings during no-fog conditions. Such shutters are only opened when, as described above, a fog prediction algorithm indicates that fog is likely.
10 Also as described above, the shutters may be closed during, for example, car washing, or when the car is parked. This mode of operation minimizes contamination when the visibility sensor functionality is not needed. The foregoing approach may be implemented by including means for generating a closure signal, which is applied to the shutters, when a closure condition exists. The closure condition may be one condition selected from the group consisting of a condition
15 where a transmission of an automotive vehicle is in a neutral condition, a condition where the transmission is in a parked condition, and a condition where an engine of the vehicle is stopped.

In addition, it should be understood that the presence of fog is unlikely during rain or snow. Accordingly, in one embodiment, precipitation sensor 35, such as a rain sensor or a snow sensor, is provided which generates an output signal. The output signal, in one
20 embodiment, may be directed to microcomputer 26, which in turn is configured to generate the closure signal. The closure signal is then applied to one or both of the shutters 122 (Figure 2 and Figure 6) to cause them to close and cover the first and second openings. In an alternative embodiment, an output of sensor 35 may be used directly (*i.e.*, not directed through

microcomputer 26) to close shutters 122 to thereby cover openings 54 and 58. As is well known, rain sensor 35 may comprise a piezo-electric plate which produces a voltage when a pressure is applied.

5 An alternative embodiment of the inventive system of detecting rain or snow involves analyzing the light scattering characteristic of rain and/or snow (relative to the light scattering characteristic of fog). To fully appreciate this aspect of the invention, a description of a synchronous detection technique used in accordance with the present invention will be briefly described.

10 Referring to Figure 15, the top trace thereof represents the ON and OFF control signals generated by microcontroller 26 indicative of the ON and OFF states of light source 52. Further, photodetector 56 is configured to generate a signal having a magnitude corresponding to the intensity of the received light. Therefore, when light source 52 is OFF, photodetector 56 generates an output signal having a magnitude corresponding to the intensity of only the ambient light. When light source 52 is ON, however, photodetector 56 generates an output signal having
15 a magnitude corresponding to the intensity of a combination of the ambient light, and the light scattered from sample volume 30 from light source 52.

Referring now to the middle trace in Figure 15, microcontroller 26 internally generates a scaler or multiplier parameter which alternates in polarity, in synchronous registry with the ON/OFF states of light source 52. That is, when light source 52 is ON, the multiplier
20 is "+1", while when the light source 52 is OFF, the multiplier is "-1".

In operation, the scaler is used to filter out the effect of ambient light (bias component). Referring now to the bottom trace of Figure 15, during a first time slot when light source 52 is ON, the multiplier is "+1". The output of photodetector 56 is multiplied or scaled

by the multiplier parameter (middle trace). Therefore, the output of detector 56 is maintained in a positive polarity state, and is represented diagrammatically as the combination of AL_1 , and SL_1 . During the next time slot, when light source 52 is OFF, the multiplier is “-1”. During this time slot, the output of detector 56 corresponds solely to the ambient light. The resulting product is of a negative polarity, and is designated AL_2 in Figure 15. Over the course of a preselected interval (“time constant”), designated in the lower trace of Figure 15 as “TC”, the area under the curve is added by microcontroller 26 having due regard for the indicated polarity. The ambient light terms (*i.e.*, $AL_1, AL_2, AL_3, AL_4, \dots, AL_8$) cancel out or, in other words, net out to “zero”. Since the scaler is always “+1” when light source 52 is ON, the accumulated value resulting from the “addition” operation is a function only of the scattered light derived from sample volume 30 due to the illumination thereof by light source 52 (*i.e.*, the sum of SL_1, SL_2, \dots, SL_4). The magnitude of the accumulated scattered light is then correlated to predetermined data, and a measure of visibility is determined thereby. For example, the time constant TC, when used to detect fog, may be selected to be between about 10-60 seconds, and may be up to several minutes.

However, in accordance with the present invention, raindrops (or snowflakes) can be analyzed (*i.e.*, detected) by shortening the time constant TC, which may be selected to be between about 10-20 milliseconds, up to about 100 milliseconds. Individual readings (*i.e.*, one reading is the accumulated value over one time constant TC) compared with each, for example, over a relatively long period of time relative to the selected time constant (*i.e.*, a detection interval), such as one minute, if widely fluctuating, are indicative of raindrops or snowflakes. In contrast, if each of the individual readings show little variation in magnitude (*i.e.*, smooth), then what is being detected is likely fog.

Preferably, whether a dedicated sensor 35 is used, or whether precipitation (rain or snow) is determined parametrically by shortening the time constant as described above, preferably at least two, and most preferably at least three of such sensors 35 (or sensor head assembly 28 when precipitation is detected parametrically) are used to minimize false detections.

5 Use of a plurality of sensors is also preferred for fog detection as well. False signals, caused by many reasons other than fog or rain (or snow), can be significantly reduced using two sensors simultaneously. For example, sensor head 28 may be employed in both a right and a left fog lamp assembly, as shown diagrammatically in Figure 16.

Referring now to Figures 7 and 8, a housing 124 is shown having a removable
10 sensor head 100 and an electronic module 126. Electronic module 126 may have different variations. Preferably, electronic module 126 contains many of the features of Figure 2 such as a micro controller 26, a memory 32 and a communications link 40. Also in some applications electronic module contains algorithms to determine the true fog occurrence from such data provided by an atmospheric pressure sensor 34, a temperature sensor 36, a humidity sensor 38.
15 The sensors may be coupled to each fog sensor. To reduce cost and avoid redundancy, however, one or all sensors may be located in a central location if a group of visibility sensors are used in a single system, for example, along a highway.

Bottom surface 120 of removable sensor head 100 is preferably flush with bottom
surface 128 of housing 124. For applications, where the visibility sensor will be mounted to a
20 moving vehicle, providing bottom surface 120 of sensor head 100 flush with bottom surface 128 of housing 124 does not disturb the laminar flow near openings 54 and 58.

Removable sensor head 100 may be snap fit within housing 124. A mechanical fastening device 130 may also be used to secure removable sensor head 100 within housing 124.

Mechanical fastening device 130 may, for example, be used in conjunction with screws or other fasteners to secure sensor head 100 within housing 124. The particular mechanical fastening device 130 is preferably relatively easy to disassembly and reassembly to facilitate replacement of sensor head 100.

5 Electronic module 126 may also be designed to be easily removed from within housing 124. In the practical sense, sensor head 100 is more likely to be replaced or serviced. Electronic module 126 may be coupled to an external power supply through a connector 132. Connector 132 may also be used to couple electronic module 126 to a remote display 134. Display 134 may also be coupled through a central computer or host controller. Remote display
10 134 may be a warning signal or an audible signal. Remote display 134 may provide an indication as to the distance of visibility. Display may be a visual indicator, an audible indicator or a combination of the two. If the fog sensor is coupled to a vehicle, the visual indicator may be incorporated into an instrument panel or a heads-up display. The audible indicator may be a buzzer or be coupled to the audio system of the vehicle.

15 A gasket 136 may be used between removable sensor head 100 and housing 124 to prevent infiltration of moisture into housing 124. Likewise, connector 132 may be a sealed connector to prevent water from entering housing 124.

 Referring now to Figure 8, a heater 138 may be coupled adjacent to first hollow opening 58 and second hollow opening 54. By placing heater 138 near openings 54 and 58, frost
20 is prevented from building up around either opening. If frost forms on the edge of either opening, the accuracy of the detector system may be affected.

In operation, removable sensor head 100 has thus been made easy to remove and replace from housing 124. To replace removable sensor head 100, mechanical fastening device 130 releases removable sensor head 100. Connectors 113 and 114 are disconnected.

To connect a replacement sensor head, connectors 113 and 114 are connected to removable sensor head 100. Mechanical fastening device 130 is coupled to the replacement sensor head 100. The calibration data from calibration memory 116 is then communicated to micro controller 26. The calibration data was stored within calibration memory 116 during manufacture of the sensor head.

Referring now to Figures 9 and 10, the removable sensor head configuration is particularly suitable for implementation within an automotive vehicle. This feature may be included as an after-market application or as original equipment. One manner for implementing a removable sensor head 100 into an automobile is to place removable sensor head 100 into a rear view mirror housing 140. Removable sensor head 100 is preferably placed behind mirror 142 and directed in a downward position. Bottom surface 120 of sensor head 110 is preferably flush with bottom 144 of rear view mirror housing 140. In this manner, the laminar flow of air around mirror housing 140 is least disturbed.

Electronic module 126 may also be incorporated within rear view mirror housing 140. However, electronic module 126 may easily be incorporated into the interior of the automotive vehicle. By placing electronic module 126 within the interior of the automotive vehicle, the electronics are not subjected to the harsh weather conditions and thus may increase the accuracy and life of electronic module 126.

It is desirable to include shutters 122 in an automotive application. It is desirable to close shutters 122 during a car wash to prevent soap residue from building on the light detector

or light source. By providing shutters 122, the life of sensor head 100 may be increased. Shutters 122 may also be applied to a highway sign application.

Referring now to Figure 11, an automotive vehicle 146 has a roof 148. A removable sensor head 100 is shown coupled near the rear end of roof 148. Sensor head 100 may be positioned to reduce wind resistance. Electronic module 126 may be placed in many areas of vehicle including within the interior of the vehicle adjacent to display unit 134 with appropriate wiring. Display unit 134 and electronic module 126 may, for example, be mounted to a rear view mirror within the vehicle.

Electronic module 126 may also be coupled to vehicle battery 150 which provides power for the entire detector system 10.

Sensor head 10 may be removable or fixed when included in an automotive vehicle. Sensor head 10 may, for example, be placed in the trim around the rear window of the vehicle. In such a manner, sensor head 100 becomes unobtrusive.

Referring now to Figures 12, 13 and 14, removable sensor head 100 may be detachable from automotive vehicle 146. By providing a detachable housing 152, visibility detector system 10 is particularly suited for after-market automotive applications. Detachable housing 152 preferably has magnets 150 suitable for coupling detachable housing 152 to a steel component such as roof 148 or a vehicle door 155.

Removable sensor head 100 may be removed from and coupled to detachable housing 152 as described above. As is best shown in Figures 13 and 14, the housing 152 may have legs 156. Legs 156 have magnets 150 therein for attachment to the automotive vehicle.

As shown in Figure 13, sample volume 30 may be between detachable housing 152 and the exterior automotive vehicle 146.

As shown in Figure 14, sample volume 30 may be directed away from automotive vehicle 146.

For an after-market application, an automotive vehicle owner merely couples the detachable housing 152 to the outside of automotive vehicle 146. Display device 132 and electronic module 134 may, for example, be clipped to a rear view mirror within the passenger compartment of automotive vehicle 146. Electronic module 126 may, for example, be powered through the cigar lighter of the automotive vehicle which is coupled to vehicle battery 150. One cable having a plurality of wires may be used to couple detachable housing 152 and removable sensor head 100 therein to electronic module 126.

In operation, a sensor head for an automotive vehicle may be used to activate the fog lights that are commonly found on the front of vehicles (and the rear of vehicles in Europe). Such a system may work as follows: once the saturation detects that fog is likely, the shutters 122 are opened; if fog is detected, the fog lights of the vehicle may then be illuminated.

Figure 16 shows exemplary vehicle 20 including a first and a second combination visibility sensor/fog lamp apparatus 200. Apparatus 200, in one embodiment, is an integral unit including the functionality of the above-described visibility sensor with the illumination functionality of a conventional fog lamp assembly. As shown in Figure 16, apparatus 200 may be disposed in a front bumper fascia of vehicle 20.

An automotive fog sensor according to this invention is characterized by a no window/no lens approach, an optimal airflow design, may include an optional shutter, and may be deployed as a 2 or 3 unit system for double or triple redundancy, respectively.

The no window/no lens approach eliminates window surface contamination. Optimal airflow design minimizes air turbulence, produces an air-curtain to minimize IR

LED/photo-detector contamination, and may use “filtered” air for the IR LED/photo-detector chamber. The optional shutter may be (i) activated by a “fog prediction filter” using humidity/temperature sensors; (ii) activated by a gear position (closed at neutral/park); or (iii) activated by a rain or precipitation detector (closed in the rain). Double/triple redundancy in the system (*e.g.*, sensor installed in both fog lamps like as shown in Figure 16) enhances reliability.

The embodiments illustrated in Figures 17-18, and Figures 19-20 will be referred to hereinafter as “look-forward” embodiments, inasmuch as the optically sensitive volume 30 is “forward” of the apparatus, relative to the direction of travel of the vehicle. Figures 17 and 18 show a first embodiment of apparatus 200, which includes a unit housing assembly 210, a lamp assembly 212, and a visibility sensor head assembly 214. As illustrated in Figure 18, apparatus 200 may include one or more electrical connections to electronic module 126, to thereby access the functionality of the electronic module 126, which is illustrated and described in connection with, for example, in Figure 2. As described above, and in the Background, a problem with conventional visibility sensors involves contamination of the light source/photo-detector and/or surfaces or structures (“windows”) through which the illumination light and the signal light must pass. To address this problem, and in accordance with the present invention, apparatus 200 includes an improved sensor enclosure configured for contamination reduction.

With continued reference to Figures 17 and 18, unit housing assembly 210 includes a plurality of relatively thin-walled structures 216₁, 216₂, 216₃, and 216₄. The thin-walled structures may comprise conventional and well-known materials.

Lamp assembly 212 is configured to produce illumination in response to an excitation signal, and may generally comprise conventional and well-known components and

materials. Lamp assembly 212 may include a reflector 218, a bulb 220, a lens or other light transmissive material 222, and an electrical connection 224 for connecting bulb 220 to a source of electrical power such as may be controlled by microcontroller 26 (*i.e.*, the excitation signal) and wherein the electrical power may be supplied by power source 76.

5 Sensor head assembly 214 includes a sensor enclosure 226 having a plurality of relatively thin-walled structures (“walls”) 228₁, 228₂, 228₃, and 228₄. Walls 228_i (where *i* = 1 to 4) define a first optical port 230 having a first opening 232, and walls 228_i further define a second optical port 234 having a second opening 236. Optical port 230 is a volume bounded in-part by wall 228₂ on the top, and wall 228₄ on the right (with reference to Figure 17), while optical port
10 234 is bounded in-part on the left by wall 228₄, and wall 228₂ on the top. First optical port 230 is optically isolated from second optical port 234 primarily by intervening wall 228₄. Sensor enclosure 226 further includes an exit opening 238, a first deflector 240 having a first aperture 242 and a second aperture 244, and a second deflector 246.

 Light source 52, and photodetector 56 are located in respective relatively
15 “concealed” positions within first optical port 230, and second optical port 234. “Concealed” in this context means positions that are difficult for contaminants (such as moisture, water, dust, etc.) to reach. In the illustrated embodiment, sensor enclosure 226 and light source 52 (disposed in first optical port 230) are configured to emit a light beam through first aperture 242 and first opening 232 to illuminate sample volume 30 located outside apparatus 200. Likewise, in the
20 illustrated embodiment, enclosure 226 and light detector 56 (disposed in second optical port 234) are configured to detect light through second aperture 244 and second opening 236. Detector 56 generates an output signal in response thereto indicative of the amount of light scattered from particles contained in the sample volume 30 (after the signal is “filtered”--as described above to

remove contributions of ambient light). As illustrated, openings 232 and 236 are located on a first side of deflector 240, while light source 52 and photodetector 56 are located on a second side opposite the first side of deflector 240. Inasmuch as openings 232 and 236 are in direct communication with the ambient environment--the source of contaminants--the foregoing arrangement (*i.e.*, use of deflectors and use of "concealed" positions) provides a barrier reducing or minimizing the entry of dust, water or other contaminants. In addition, as the vehicle moves in a forward direction, respective air flows occur along the paths indicated by arrows designated 248 in the drawings. Dust, water, or other contaminants in the air will pass through the sensor enclosure 226 along the air flow path. This flow-through action reduces the likelihood that the surfaces of light source 52 and photodetector 56 will become contaminated.

In addition, by selecting a proper air flow path difference between the inside of enclosure 226 relative to the outside of enclosure 226, and, further, by selecting proper sizes for the openings 232, 236 and 238, an air pressure differential can be established. That is, one can make the air pressure adjacent and around light source 52 and photodetector 56 higher than the pressure in the central portion of enclosure 226. This pressure differential feature helps reduce contamination. Basic principles of aerodynamics may be used to make the above selections.

Thus, two features of the above-described configuration combine to keep the surfaces of light source 52 and photodetector 56 clean: (1) a "concealed" position feature wherein the source 52 and photodetector 56 are located in "concealed" positions (*e.g.*, above the apertures, and openings, through which the illumination and receiving light beams pass); and (2) a pressure differential feature wherein the enclosure and deflectors and openings are configured to create suitable air paths to establish a pressure differential to thereby assist in keeping the

surfaces of source 52 and detector 56 clean. With the foregoing implementation, the use of one or more shutters, such as shutters 122 in Figure 6, is optional.

Figures 19 and 20 illustrate a second preferred embodiment of the apparatus shown in Figure 17 and 18, namely apparatus 200'. Apparatus 200' is substantially similar to apparatus 200, except that apparatus 200' does not include second deflector 246, but in lieu thereof includes exit opening 238 that is positioned at a distal end of an air flow channel 250. Apparatus 200' illustrates just one of the plurality of variations and modifications of enclosure 226 possible which are adapted to create air flow path differences to thereby establish the above-described pressure differential arrangement.

Figures 21 and 22 illustrate yet another preferred embodiment, namely apparatus 200''. Apparatus 200'' will be referred to as a "look-down" embodiment wherein the optically sensitive volume 30 is located on the "down" side or downward of the apparatus enclosure, relative to the direction of travel of vehicle 20. Apparatus 200'' includes unit housing 210, lamp assembly 212, and sensor head assembly 214''. Unit housing 210 and lamp assembly 212 may comprise structure and function as described above in connection with the embodiments illustrated in Figures 17-20. Sensor head assembly 214'' includes a sensor enclosure 226'' having a plurality of walls 228₁, 228₂, 228₃, 228₄, and 228₅, that define a first optical port having a first opening and a second optical port having a second opening, as described above in connection with apparatus 200. Enclosure 226'' includes a deflector 240'' having first and second apertures 242, and 244. In the illustrated embodiment, apparatus 200'' creates an air flow path difference that establishes a pressure differential in the same manner and to the same effect as described above in connection with apparatus 200 and 200'. Figure 21 is a bottom view of

Figure 22. In addition, apparatus 200'' includes an air filter 260 configured to filter air for the IR LED 52/photodetector 56 chamber. This is shown in both Figures 21 and 22.

Figures 23 and 24 illustrate still yet another preferred embodiment of the present invention, namely apparatus 200'''. Apparatus 200''' includes a unit housing 210, a lamp assembly 212, and a sensor head assembly 214'''. Unit housing 210, and lamp assembly 212 may comprise structure and function as described above in connection with the embodiments illustrated in Figures 17-22. Apparatus 200''' may be generally cylindrical in shape, and comprise a sensor enclosure 226''' that includes a first deflector 240'', and a second deflector 246''. Walls, including thin walls 256₁, and 256₂, in-part, define first optical port 230, and second optical port 236. First and second openings 232 and 236 are best shown in Figure 23. First deflector 240''' includes first aperture 242'', and second aperture 244'', while second deflector 246''' is illustrated as including third aperture 252, and fourth aperture 254. Apertures 242'', and 252 are, generally, in registry, while apertures 244'' and 254 are, likewise, generally in registry. The foregoing configuration permits light source 52 to generate a light beam to illuminate optically sensitive sample volume 30, while the apertures as described above permit photodetector 56 to receive light therethrough from scattered particles in the optically sensitive sample volume 30. Operation of apparatus is generally the same, in manner and effect, as described above in connection with apparatus 200.

Certain other improvements are shown in Figures 21-22 and 25-28.

In addition to passing air through the sensor enclosure in front of the apertures for IR LED and photodetector (*e.g.*, 242, 244 in Figure 19/20), a small hole is made to the IR LED/photodetector chambers and is covered with an air-filter 260. With this configuration, high pressure air 266 goes through the filter 260 wherein clean air continuously flows in the chambers

to prevent contamination on the surfaces of the LED 52 and detector 56 (as if one were continuously using a vacuum cleaner to clean the surfaces). This is shown in both Figures 21-22 (apparatus 200') and Figures 25-26 (apparatus 200iv).

5 Figures 25-26, in addition, show a support 262, and a shutter 264 installed at opening 236. In addition, there may be provided a second shutter 264 at opening 232. These shutters 264 may be controlled in a manner described hereinbefore to selectively cover the openings and isolate the inside chamber from external environmental factors.

10 Air-flow channels are shown in Figure 27. This channel, which is formed by the under surface of apparatus 200 and the upper surface 270 of bumper portion 268, creates a "steady" air current which works as an "air-curtain" for the openings, keeping external contaminants out.

Figure 28 shows a modularized sensor head unit 100', being configured to be removable relative to enclosure 102', in a manner similar to that described above for removable sensor head 100 and enclosure 102.

15 While the best mode for carrying out the present invention has been described in detail, those familiar with the art to which this invention relates will recognize various alternative designs and embodiments for practicing the invention as defined by the following claim. For example, the humidity, temperature and atmospheric pressure sensors may be replaced by a wind velocity sensors if this invention were to be used to measure visibility in blowing dust.

CLAIMS

1. A visibility sensor assembly comprising:
a housing having a sensor head opening;
a removable sensor head assembly removably coupled to said housing within said
sensor head opening, said sensor head assembly having a sensor enclosure and a connector; and
5 an electronics module coupled to said sensor head through said connector.

2. A visibility sensor assembly as recited in claim 1, wherein said electronics module
is coupled within said housing.

3. A visibility sensor assembly as recited in claim 1, wherein said sensor enclosure
defines a first optical port and a second optical port each having a respective first hollow opening
and a second hollow opening.

4. A visibility sensor assembly as recited in claim 3, wherein said removable sensor
head assembly further comprises:

a first circuit board coupled to said sensor enclosure;
a first connector coupled to said first circuit board;
5 a light source coupled to said first circuit board, said first circuit board positioning
said light source within said first optical port;
a second circuit board coupled to said sensor enclosure;
a second connector coupled to said second circuit board; and

a light detector coupled to said second circuit board, said second circuit board positioning said light detector within said second optical port.

5. A visibility sensor assembly as recited in claim 3, further comprising a first shutter for selectively closing said first hollow opening.

6. A visibility sensor assembly as recited in claim 3, further comprising a second shutter for selectively closing said second hollow opening.

7. A visibility sensor assembly as recited in claim 1, further comprising a heater positioned adjacent to said first hollow opening.

8. A visibility sensor assembly as recited in claim 1, wherein said housing includes a housing bottom surface and said sensor head assembly includes a sensor bottom surface flush with said housing bottom surface.

9. A visibility sensor assembly as recited in claim 1, further comprising a gasket sealing said sensor head opening.

10. A visibility sensor assembly as recited in claim 1, further comprising a magnet coupled within said housing.

11. A visibility sensor assembly as recited in claim 1, wherein said housing is an exterior mirror housing.

12. A visibility sensor assembly as recited in claim 1, further comprising a mechanical fastening device coupling said sensor head assembly to said housing.

13. A visibility sensor for an automotive vehicle comprising:

a housing having a sensor head opening;

a sensor head assembly including a mechanical fastening device configured to removably couple said assembly to said housing within said sensor head opening, said sensor head assembly further including a sensor enclosure having a first opening through which a light source in accordance with an input signal illuminates a sample volume outside said housing and a second opening through which a light detector detects light and generates an output signal indicative of the amount of light scattered from particles in the sample volume, said input signal and said output signal terminating in one or more connectors associated with said sensor head assembly;

means for selectively covering at least one of said first opening and said second opening;

an electronics module coupled to said sensor head assembly through said connector; and

a display electrically coupled to said sensor head assembly, said display coupled within the automotive vehicle.

14. A visibility sensor as recited in claim 13, wherein said electronics module is coupled within said housing.

15. A visibility sensor as recited in claim 13, wherein said electronics module is coupled within said automotive vehicle.

16. A visibility sensor as recited in claim 13, further comprising wherein said covering means includes a first shutter for selectively closing said first opening.

17. A visibility sensor as recited in claim 16 further comprising wherein said covering means further includes a second shutter for selectively closing said second opening.

18. A visibility sensor as recited in claim 13 further comprising a heater positioned adjacent to said first opening.

19. A visibility sensor as recited in claim 13, wherein said housing comprises an exterior rearview mirror housing.

20. A visibility sensor as recited in claim 13, further comprising one or more magnets coupled within said housing.

21. A visibility sensor as recited in claim 13 wherein said covering means is responsive to a closure signal.

22. A visibility sensor as recited in claim 21 further including means for generating said closure signal as a function of at least temperature and humidity so as to open said covering means as the likelihood of fog increases.

23. A visibility sensor as recited in claim 22 wherein said closure signal generating means is further responsive to pressure.

24. A visibility sensor as recited in claim 21 further including means for generating said closure signal when a closure condition exists, said closure condition being one selected from the group consisting of a transmission of said automotive vehicle being in a neutral condition, the transmission being in a park condition, and an engine of said vehicle being in a
5 stopped condition.

25. A visibility sensor as recited in claim 21 wherein said electronics module includes means for generating said input signal as a function of temperature and humidity so that said sample volume is illuminated at a rate corresponding to the likelihood of fog.

26. A visibility sensor as recited in claim 25 wherein said input signal generating means is further responsive to atmospheric pressure.

27. A sensor head assembly for a visibility sensor unit including a housing, said sensor head assembly comprising:

a sensor enclosure having a plurality of walls defining a first optical port and a second optical port, said first optical port having a first opening associated therewith and said second optical port having a second opening associated therewith;

a light source responsive to an input signal and disposed in said first optical port, said light source being configured to emit a light beam along a first optical axis through said first opening to illuminate a sample volume located outside of said head assembly; and,

means for selectively covering at least one of said first opening and said second opening;

a light detector disposed in said second optical port and configured to detect light through said second opening along a second optical axis and generate an output signal in response thereto indicative of the amount of light scattered from particles in the sample volume,

wherein said light source and said light detector are located at respective ends of said first and second optical ports distal from said first and second openings thereof to thereby minimize contamination of said light source and said light detector due to entry of contaminants through said first and second openings.

28. A sensor head assembly as recited in claim 27 wherein said covering means comprises a first shutter configured to selectively cover said first opening and a second shutter configured to selectively cover said second opening.

29. A sensor head assembly as recited in claim 28 wherein said first and second shutters are responsive to a closure signal generated as a function of at least temperature and

humidity so as to open said first and second shutters at a rate increasing as the likelihood of fog increases.

30. A sensor head assembly as recited in claim 27 wherein said input signal and said output signal terminate in one or more connectors, said sensor head assembly further including a mechanical fastening device configured to removably secure said sensor head assembly to said housing.

5

31. An apparatus comprising:

a sensor enclosure having a plurality of walls defining a first optical port having a first opening and a second optical port having a second opening, said enclosure further including an exit opening;

10

a deflector having first and second apertures;

a light source disposed in said first optical port, said light source being configured to emit a light beam through said first aperture and said first opening to illuminate a sample volume located outside of said apparatus;

15

a light detector disposed in said second optical port and configured to detect light through said second aperture and said second opening and generate an output signal in response thereto indicative of the amount of light scattered from particles in the sample volume;

20

said first and second openings being located on a first side of said deflector, said light source and said light detector being located a second side opposite said first side of said deflector; and

wherein said enclosure is configured to allow air to flow therethrough entering said first and second openings and exiting said exit opening.

32. The apparatus of claim 31 wherein said enclosure is further configured such that the air flow occurs substantially on said first side of said deflector.

33. The apparatus of claim 31 wherein said deflector is a first deflector, said apparatus further comprising a second deflector disposed intermediate said first deflector and said exit opening.

34. The apparatus of claim 31 further including:
a lamp assembly; and,
a microcontroller configured to activate said lamp responsive to said output signal.

35. The apparatus of claim 34 wherein said apparatus is configured for installation in an automotive vehicle wherein said first and second openings lie substantially in a first plane and wherein an external airflow due to motion of said vehicle occurs generally in a direction, said sensor enclosure being configured in one of a look-forward mode wherein said direction is
5 substantially perpendicular to said first plane and a look-down mode wherein said direction is substantially parallel to said first plane.

36. The apparatus of claim 35 wherein said one mode is said look-forward mode.

37. The apparatus of claim 31 wherein said first and second ports each include respective air openings, said apparatus further including at least one air filter configured to cover said air openings.

38. The apparatus of claim 36 wherein said enclosure is configured to further include a flow channel adjacent said exit opening.

39. The apparatus of claim 36 wherein said deflector is a first deflector, said apparatus further comprising a second deflector disposed intermediate said first deflector and said exit opening.

40. The apparatus of claim 35 wherein said one mode is said look-down mode.

41. The apparatus of claim 31 further including means for selectively covering at least one of said first and second openings in response to a closure signal.

42. The apparatus of claim 41 further including a microcontroller configured to generate said closure signal upon occurrence of a closure condition selected from the group consisting of a precipitation condition, a transmission of an automotive vehicle associated with said apparatus being in a neutral or park condition, an engine of the vehicle being in a stopped condition, and when a likelihood of fog existing exceeds a predetermined level.

5

43. An apparatus comprising:

a sensor enclosure having a plurality of walls defining a first optical port having a first opening and a second optical port having a second opening, said enclosure further including an exit opening;

5 a deflector having first and second apertures;

a light source disposed in said first optical port, said light source being configured to emit a light beam through said first aperture and said exit opening to illuminate a sample volume located outside of said apparatus;

10 a light detector disposed in said second optical port and configured to detect light through said second aperture and said exit opening and generate an output signal in response thereto indicative of the amount of light scattered from particles in the sample volume;

15 said first and second openings being located on a first side of said deflector, said light source and said light detector being located a second side opposite said first side of said deflector; and

wherein said enclosure is configured to allow air to flow therethrough entering said first and second openings and exiting said exit opening.

44. The apparatus of claim 43 further including a lamp assembly.

45. An apparatus comprising:

a sensor enclosure having a plurality of walls defining a first optical port having a first opening and a second optical port having a second opening;

a light source disposed in said first optical port, said light source being configured to emit a light beam through said first opening to illuminate a sample volume located outside of said apparatus;

a light detector disposed in said second optical port and configured to detect light through said second opening and generate a first output signal in response thereto indicative of the amount of light scattered from particles in the sample volume;

means for selectively covering at least one of said first opening and said second opening;

a first precipitation sensor configured to detect a condition selected from the group consisting of a rain condition and a snow condition and generate a closure signal

in responsive thereto, said closure signal operative to cause said covering means to cover said first and second openings; and,

an electronic module responsive to said first output signal configured to generate a second output signal indicative of the presence of a visibility impairment.

46. The apparatus of claim 45 further comprising a second precipitation sensor.

47. The apparatus of claim 45 wherein said electronic module includes a microcontroller configured to analyze said output signal and generate in response thereto a precipitation signal indicative of the presence of at least one of rain and snow.

48. The apparatus of claim 47 wherein said microcontroller is further configured to generate said precipitation signal in accordance with a predetermined time constant parameter and a predetermined accumulating interval parameter.

49. The apparatus of claim 48 wherein said microcontroller is further configured to generate said precipitation signal in accordance with a variation parameter associated with said output signal.

50. The apparatus of claim 47 further comprising a second sensor enclosure having a second light source and second light detector.

51. The apparatus of claim 49 wherein said microcontroller is further configured to generate said closure signal when said precipitation signal is generated.

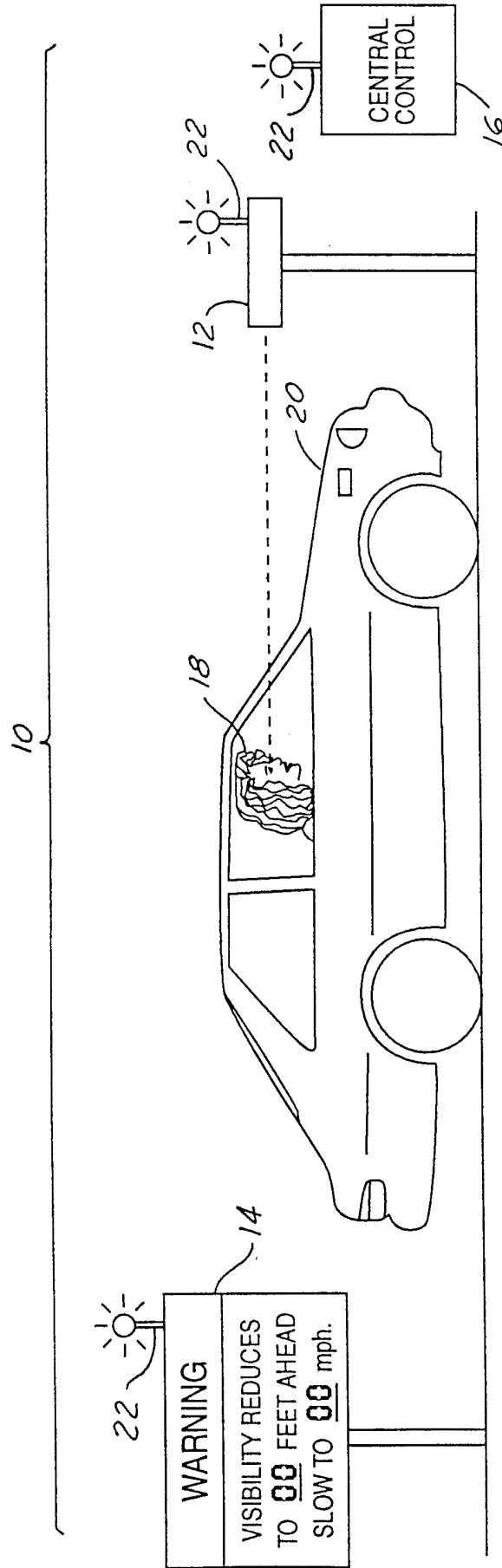

FIG. 1

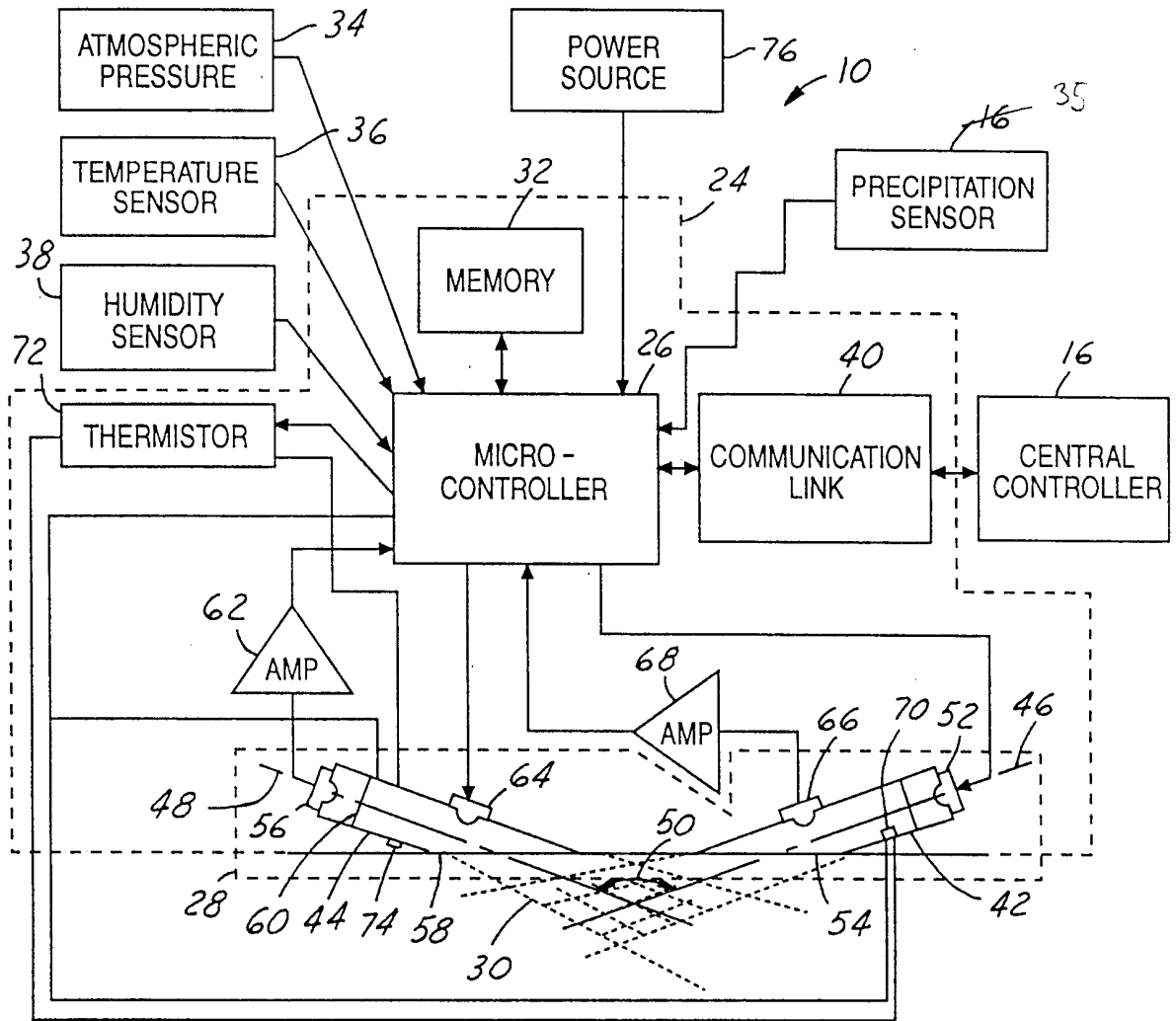

FIG. 2

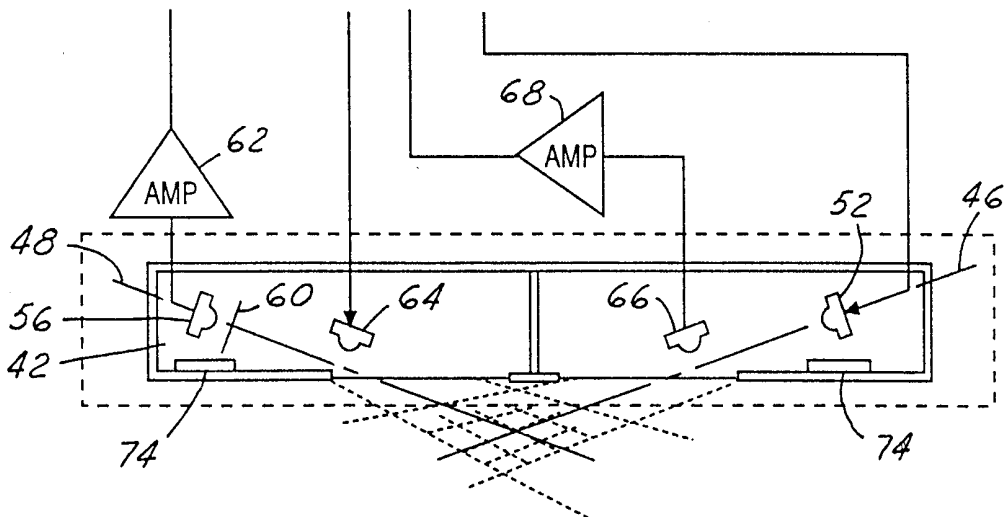

FIG. 3

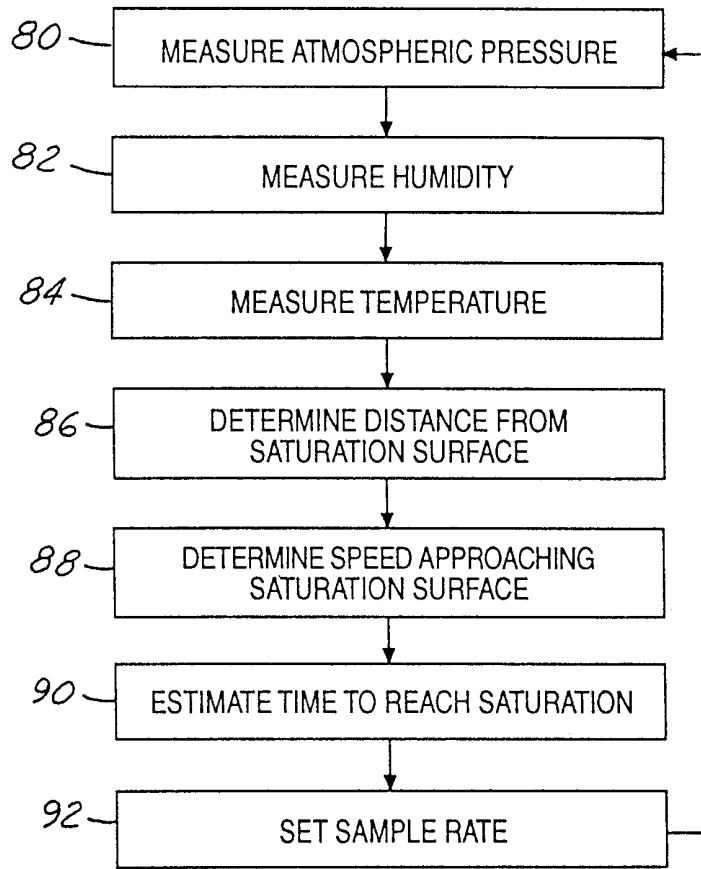

FIG. 4

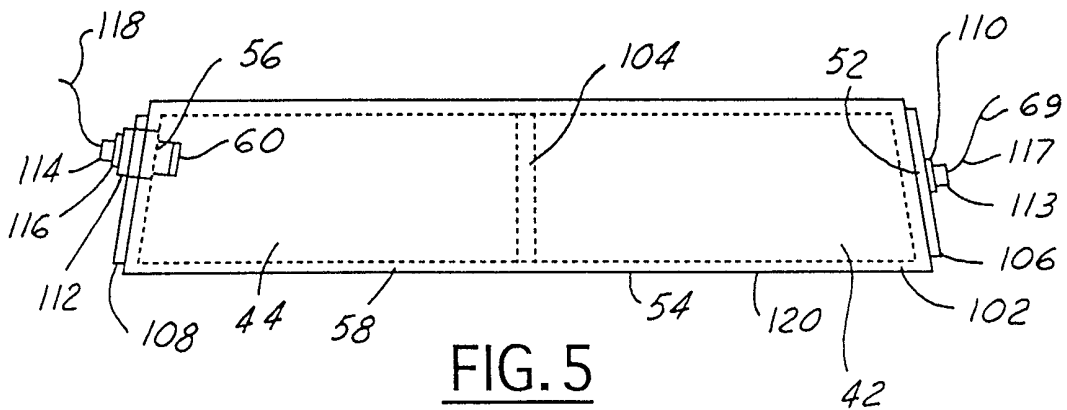
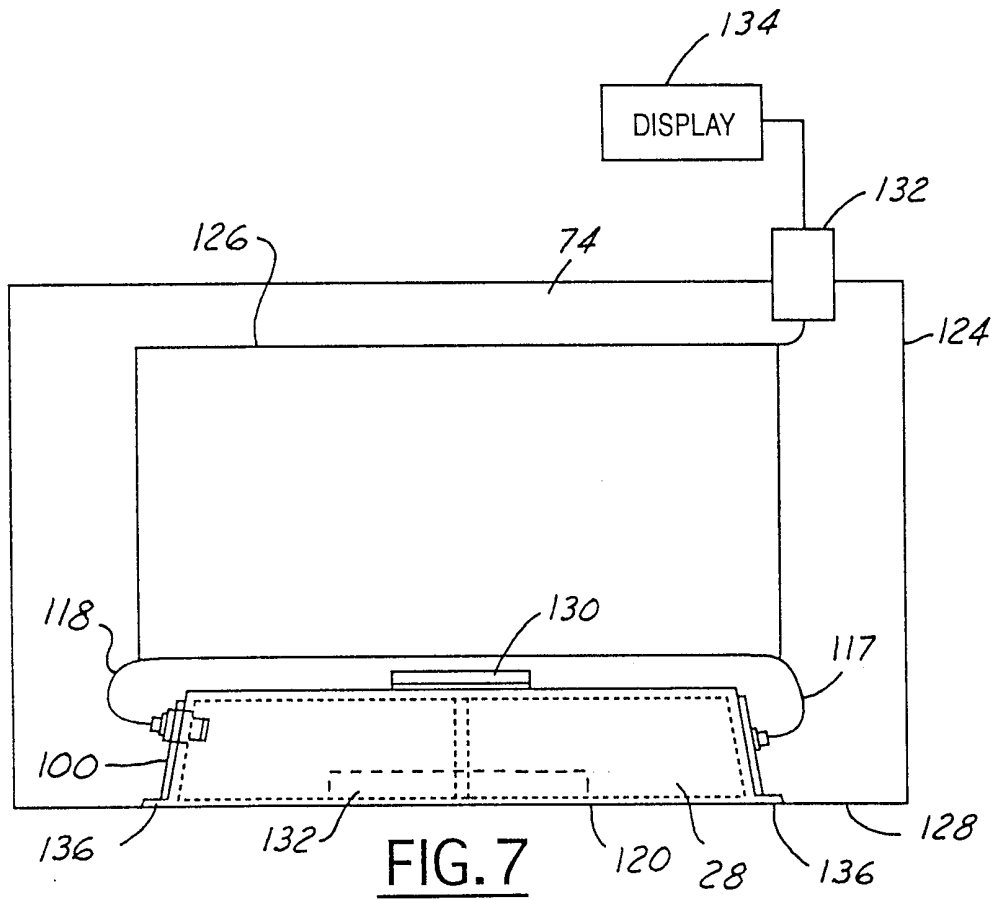
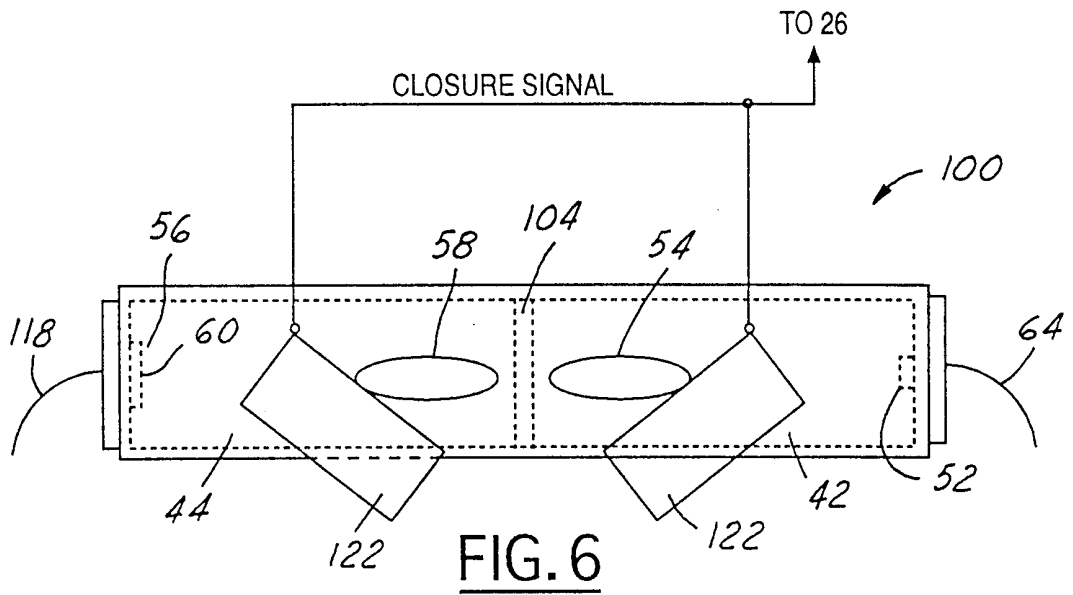

FIG. 5



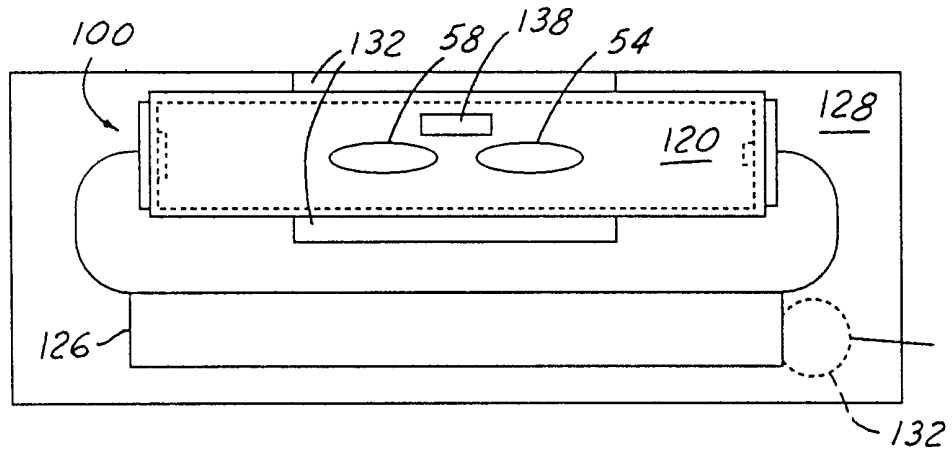

FIG. 8

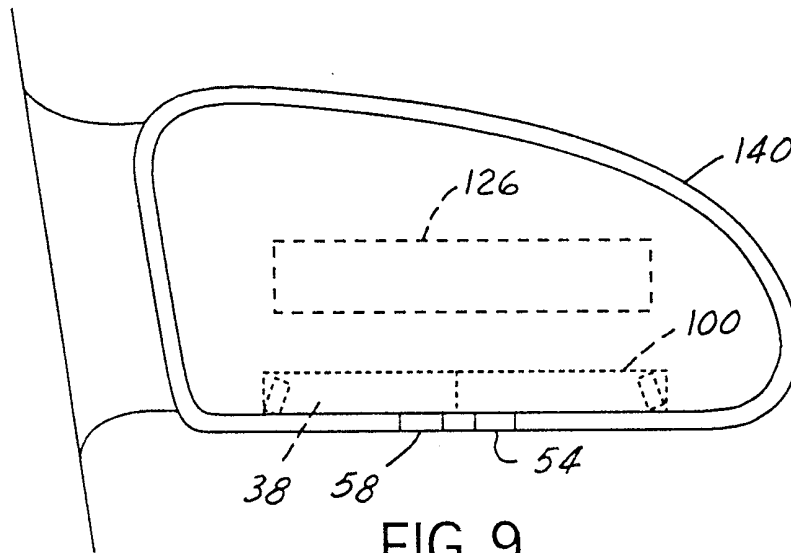

FIG. 9

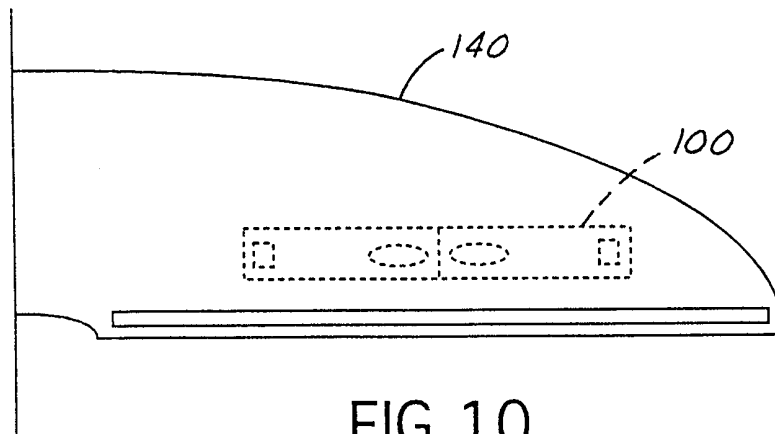

FIG. 10

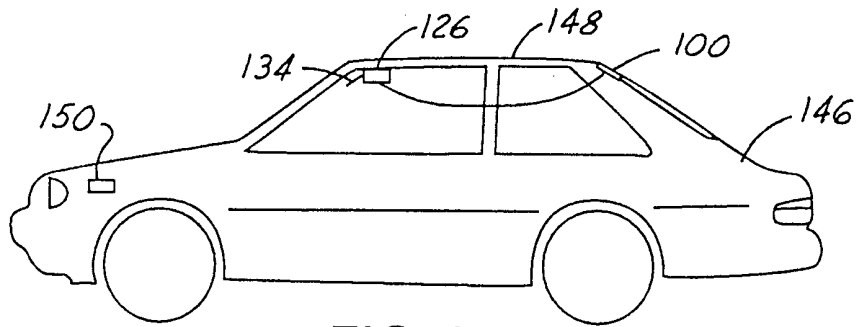

FIG. 11

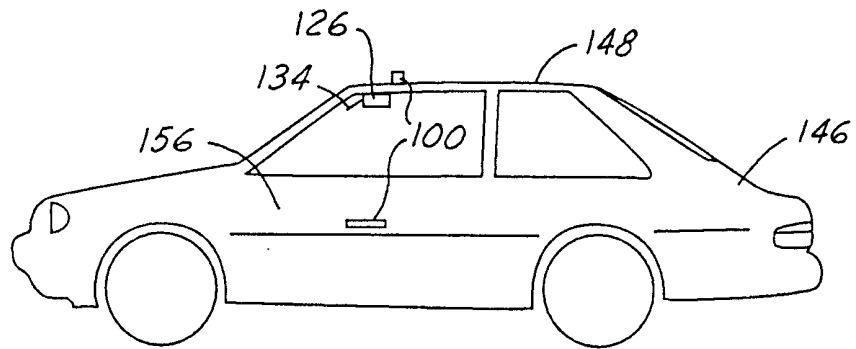

FIG. 12

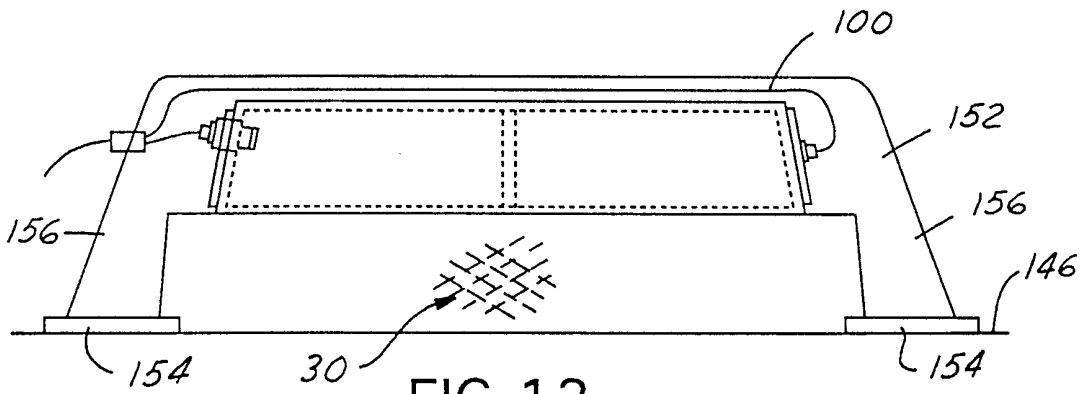

FIG. 13

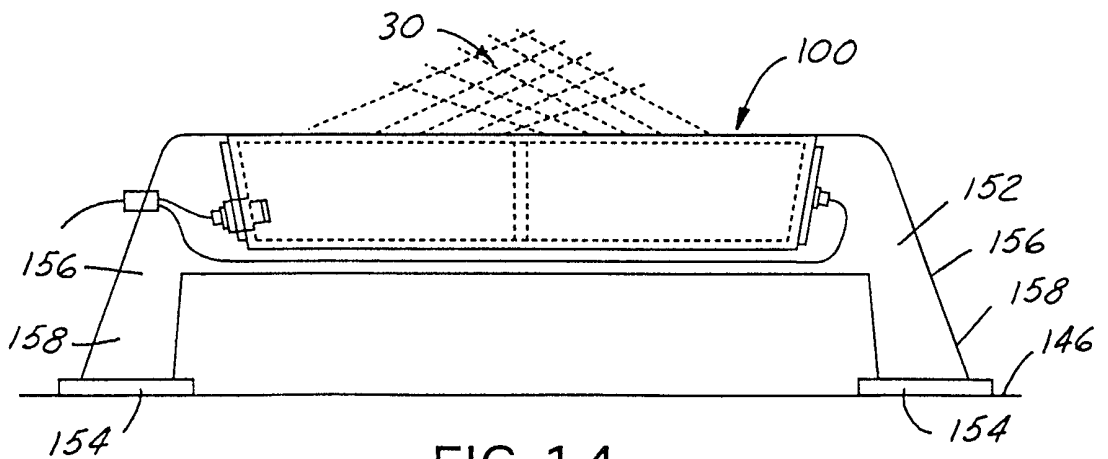

FIG. 14

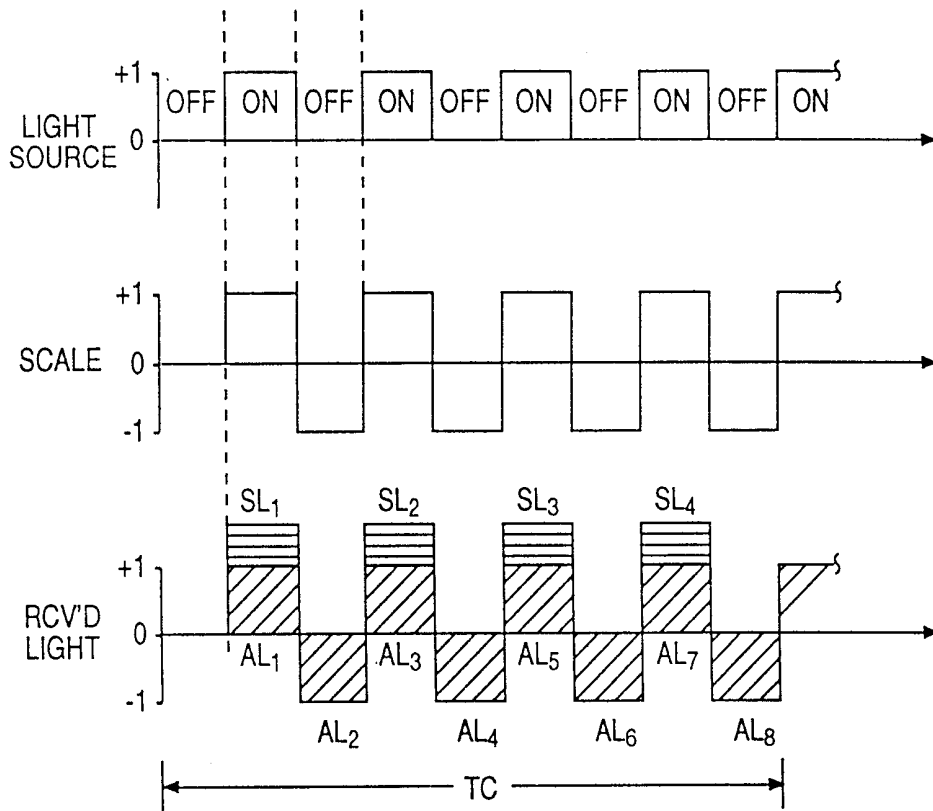

FIG. 15

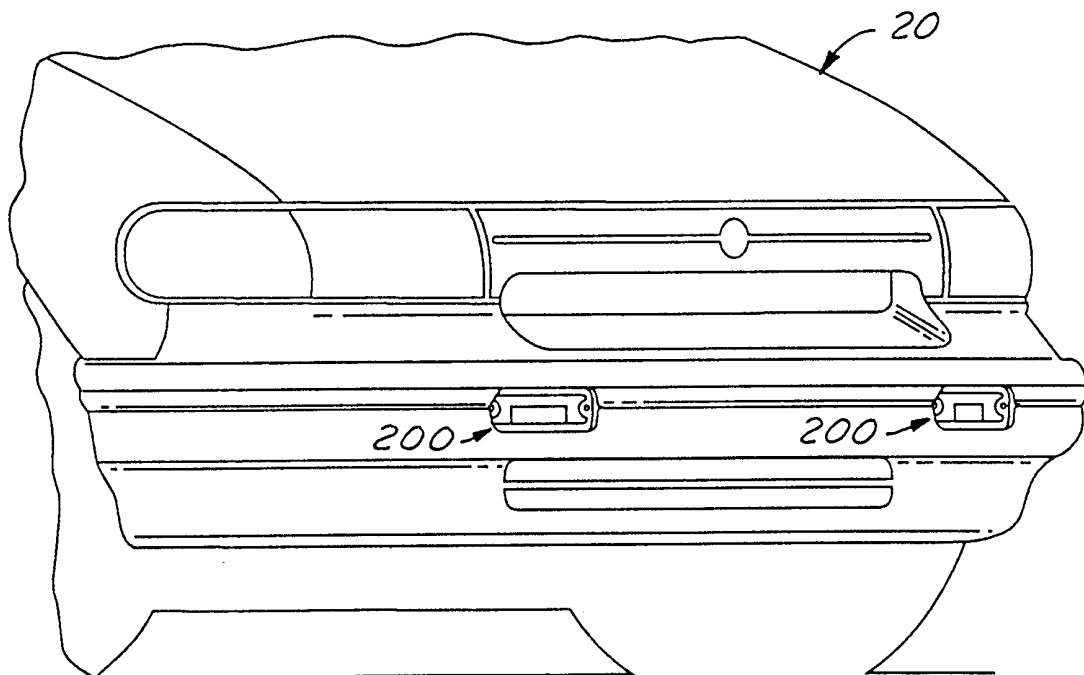

FIG. 16

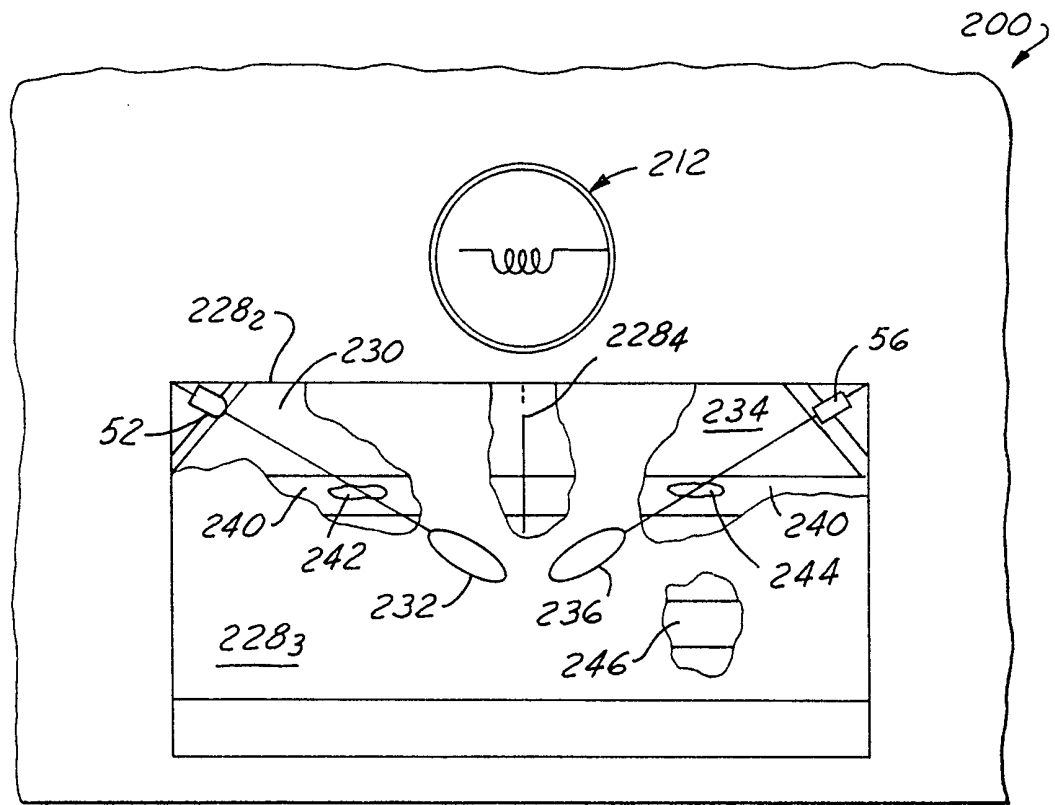

FIG. 17

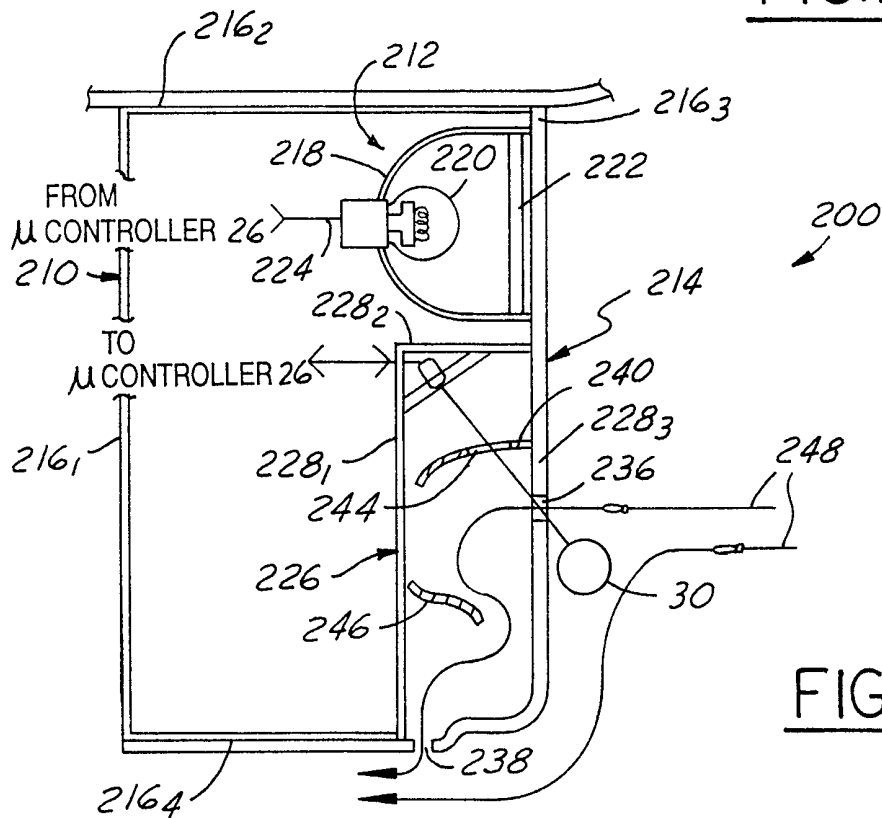

FIG. 18

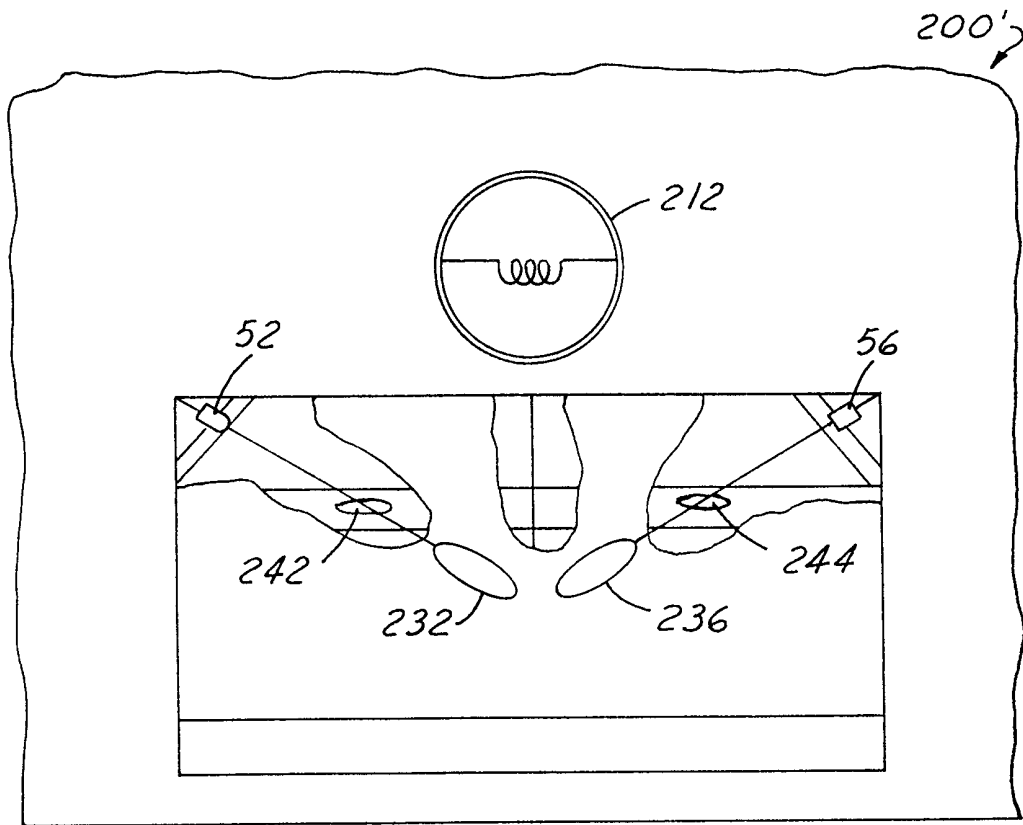

FIG. 19

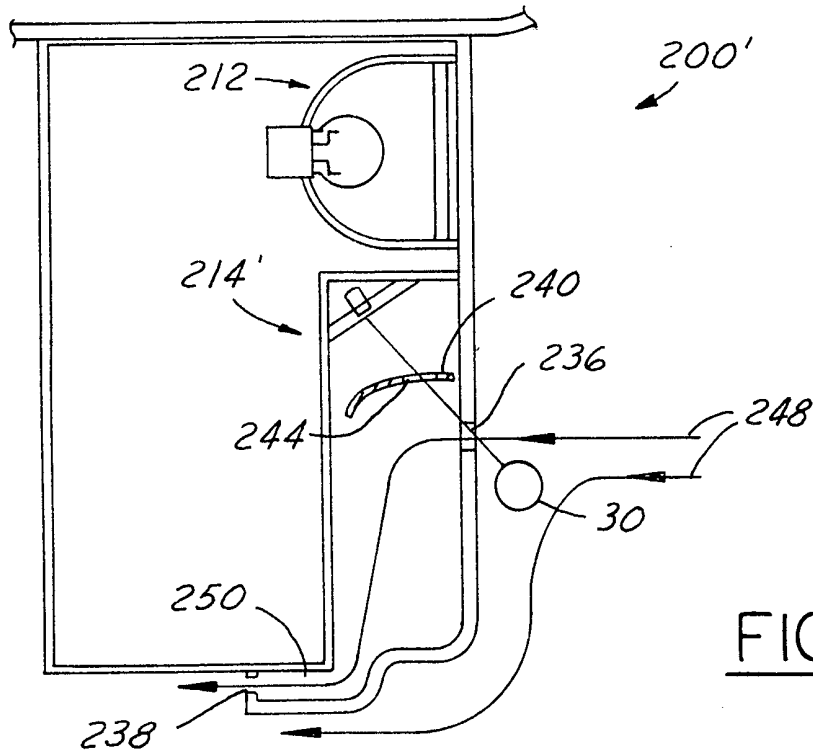

FIG. 20

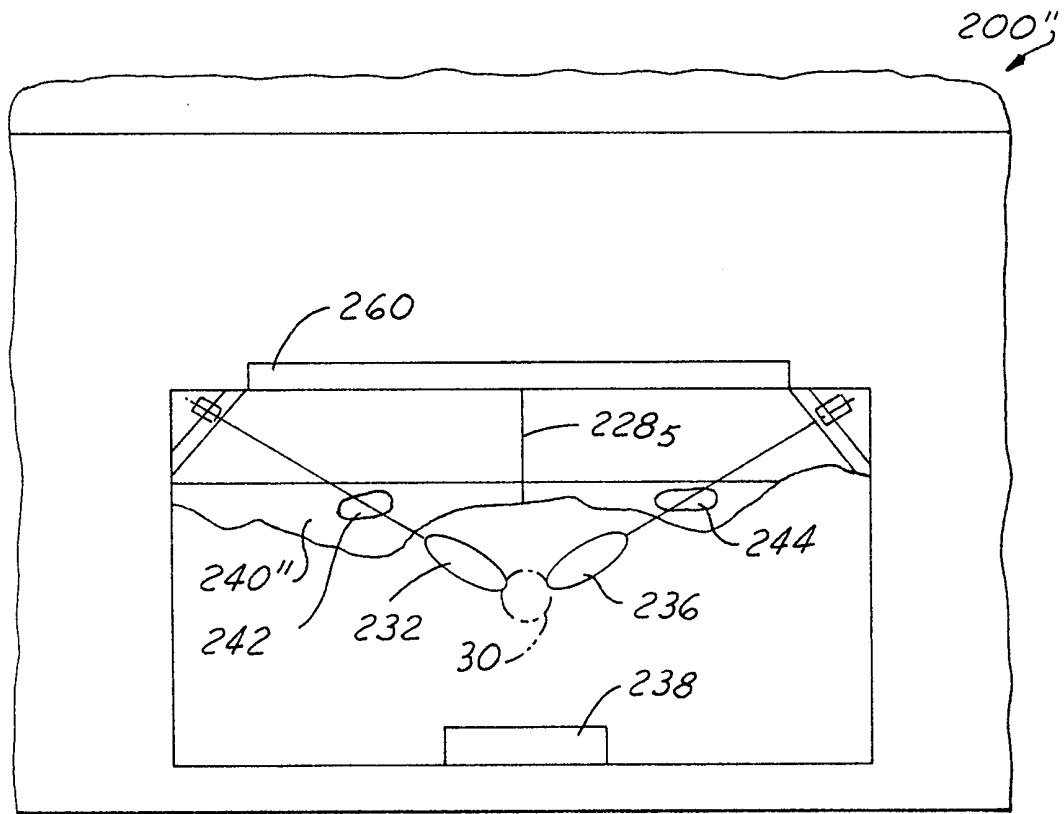

FIG. 21

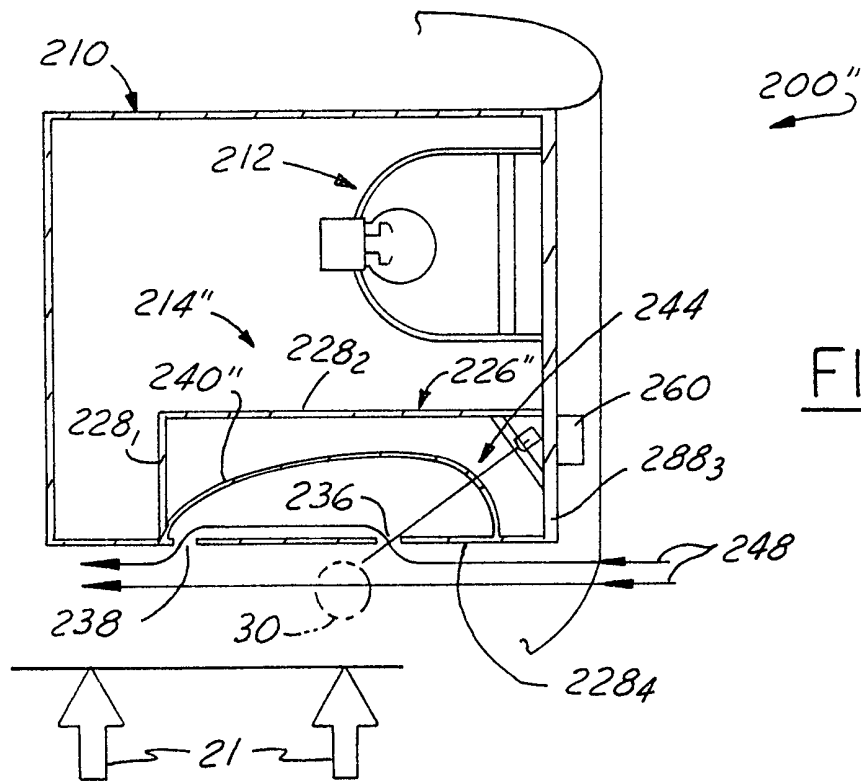

FIG. 22

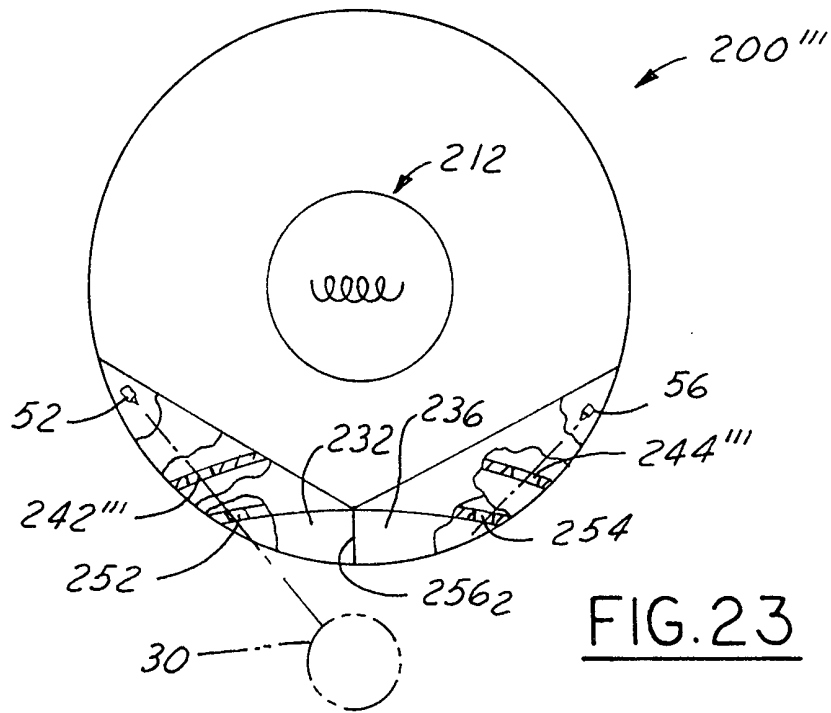

FIG. 23

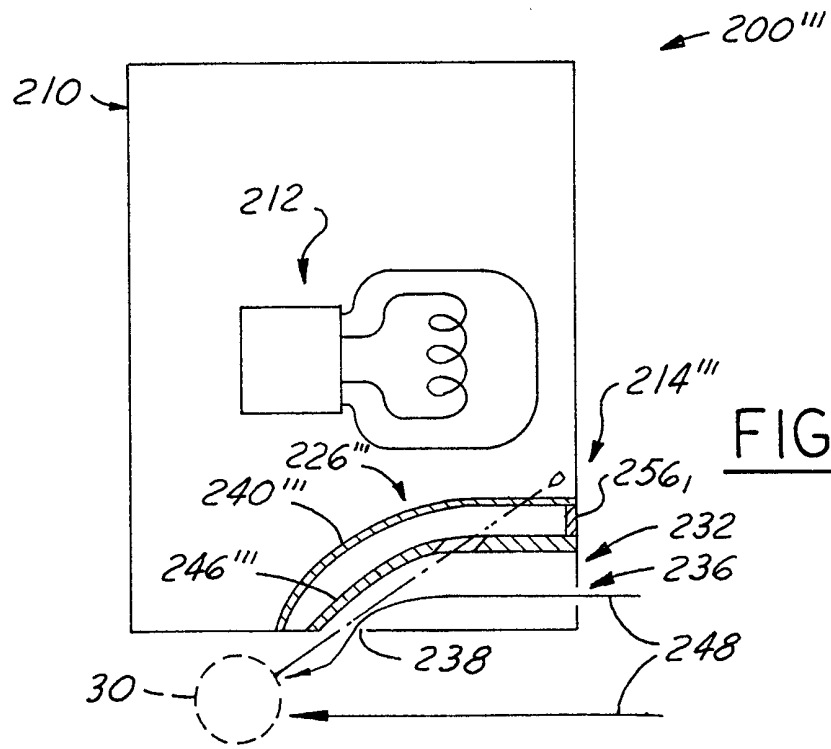

FIG. 24

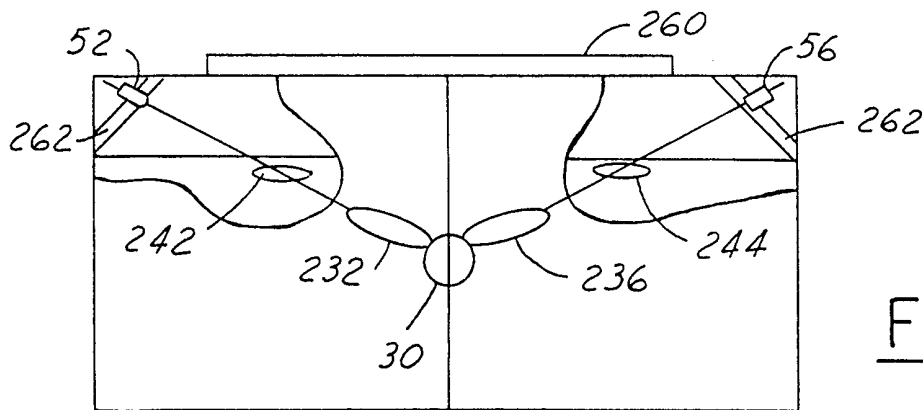

FIG. 25

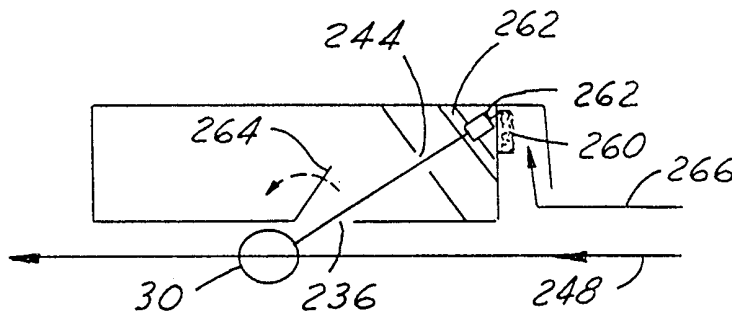

FIG. 26

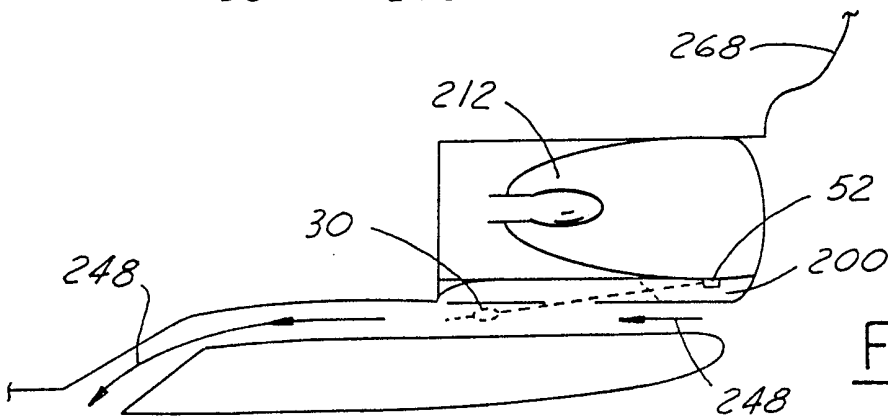

FIG. 27

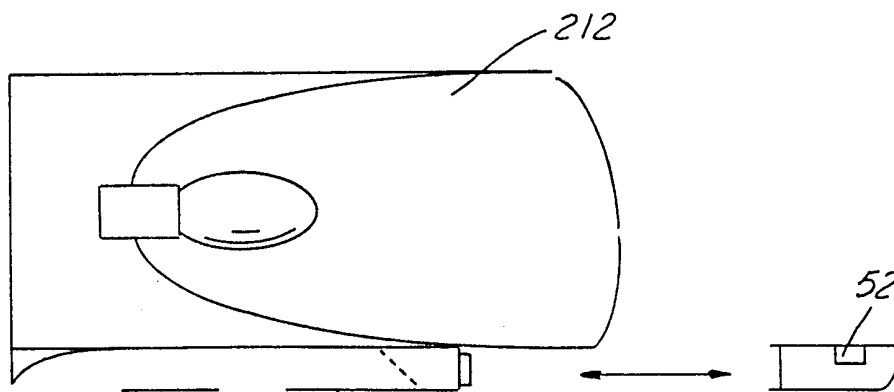

FIG. 28

INTERNATIONAL SEARCH REPORT

International application No.
PCT/US99/07135

A. CLASSIFICATION OF SUBJECT MATTER
 IPC(6) :B60Q 1/02; G08B 21/00
 US CL : 340/425.5, 601, 602; 307/10.8; 315/82, 156; 362/74, 80, 83.1
 According to International Patent Classification (IPC) or to both national classification and IPC

B. FIELDS SEARCHED
 Minimum documentation searched (classification system followed by classification symbols)
 U.S. : 340/425.5, 601, 602; 307/10.8; 315/82, 156; 362/74, 80, 83.1

Documentation searched other than minimum documentation to the extent that such documents are included in the fields searched

Electronic data base consulted during the international search (name of data base and, where practicable, search terms used)

C. DOCUMENTS CONSIDERED TO BE RELEVANT

| Category* | Citation of document, with indication, where appropriate, of the relevant passages | Relevant to claim No. |
|-----------|--|-----------------------|
| | Please See Continuation of Second Sheet. | |

Further documents are listed in the continuation of Box C. See patent family annex.

| | |
|---|--|
| * Special categories of cited documents: | *T* later document published after the international filing date or priority date and not in conflict with the application but cited to understand the principle or theory underlying the invention |
| *A* document defining the general state of the art which is not considered to be of particular relevance | *X* document of particular relevance; the claimed invention cannot be considered novel or cannot be considered to involve an inventive step when the document is taken alone |
| *E* earlier document published on or after the international filing date | *Y* document of particular relevance; the claimed invention cannot be considered to involve an inventive step when the document is combined with one or more other such documents, such combination being obvious to a person skilled in the art |
| *L* document which may throw doubts on priority claim(s) or which is cited to establish the publication date of another citation or other special reason (as specified) | * & * document member of the same patent family |
| *O* document referring to an oral disclosure, use, exhibition or other means | |
| *I* document published prior to the international filing date but later than the priority date claimed | |

| | |
|--|--|
| Date of the actual completion of the international search 21 MAY 1999 | Date of mailing of the international search report 08 JUL 1999 |
|--|--|

| | |
|---|---|
| Name and mailing address of the ISA/US Commissioner of Patents and Trademarks Box PCT Washington, D.C. 20231 Facsimile No. (703) 305-3230 | Authorized officer <i>James R. Matthews</i> JEFFERY A. HOFSSASS Telephone No. (703) 305-4717 |
|---|---|

INTERNATIONAL SEARCH REPORT

International application No.
PCT/US99/07135

| C (Continuation). DOCUMENTS CONSIDERED TO BE RELEVANT | | |
|---|---|-----------------------------|
| Category* | Citation of document, with indication, where appropriate, of the relevant passages | Relevant to claim No. |
| X ----- Y | US 5,349,267 A (BRASSIER et al) 20 September 1994, col. 1, lines 6-9, col. 2, lines 42-45, col. 5, lines 15-57, col. 7, lines 24-41. | 1-4 and 12 ----- 5-11 |
| Y | US 5,138,150 A (DUNCAN) 11 August 1992, col. 1, lines 57-67, col. 3, lines 42-68 and col. 4, lines 1-37. | 5 and 6 |
| Y | US 5,347,387 A (RICE) 13 September 1994, col. 11, lines 21-33 and col. 12, lines 51-58. | 7 |
| Y | US 4,807,096 A (SKOGLER et al) 21 February 1989, col. 1, lines 65-68, col. 2, lines 1-21, col. 6, lines 11-68 and col. 7, lines 1-16. | 8-11 |
| A | US 4,931,767 A (ALBRECHT et al) 5 June 1990, col. 1, lines 8-14, col. 2, lines 15-68, col. 3, lines 1-17 and 33-65. | 13-51 |