

(19) World Intellectual Property Organization
International Bureau



(43) International Publication Date
29 October 2009 (29.10.2009)

PCT

(10) International Publication Number
WO 2009/131860 A1

- (51) **International Patent Classification:**
H01R 13/641 (2006.01) *H01R 13/436* (2006.01)
- (21) **International Application Number:**
PCT/US2009/040356
- (22) **International Filing Date:**
13 April 2009 (13.04.2009)
- (25) **Filing Language:** English
- (26) **Publication Language:** English
- (30) **Priority Data:**
080079874 25 April 2008 (25.04.2008) EP
- (71) **Applicant (for all designated States except US):**
MOLEX INCORPORATED [US/US]; 2222 Wellington Court, Lisle, IL 60532 (US).
- (72) **Inventors; and**
(75) **Inventors/Applicants (for US only):** **BOUCHAN, Christophe** [FR/FR]; 10, Rue Des Chataigniers, F-91160 Longjumeau (FR). **DECHELETTE, Patrick** [FR/FR]; 24, Rue Des Sources, F-92350 Le Plessis Robinson (FR).
- (74) **Agent:** **GOLDEN, Larry, I.**; Molex Incorporated, 2222 Wellington Court, Lisle, IL 60532 (US).

- (81) **Designated States (unless otherwise indicated, for every kind of national protection available):** AE, AG, AL, AM, AO, AT, AU, AZ, BA, BB, BG, BH, BR, BW, BY, BZ, CA, CH, CN, CO, CR, CU, CZ, DE, DK, DM, DO, DZ, EC, EE, EG, ES, FI, GB, GD, GE, GH, GM, GT, HN, HR, HU, ID, IL, IN, IS, JP, KE, KG, KM, KN, KP, KR, KZ, LA, LC, LK, LR, LS, LT, LU, LY, MA, MD, ME, MG, MK, MN, MW, MX, MY, MZ, NA, NG, NI, NO, NZ, OM, PG, PH, PL, PT, RO, RS, RU, SC, SD, SE, SG, SK, SL, SM, ST, SV, SY, TJ, TM, TN, TR, TT, TZ, UA, UG, US, UZ, VC, VN, ZA, ZM, ZW.
- (84) **Designated States (unless otherwise indicated, for every kind of regional protection available):** ARIPO (BW, GH, GM, KE, LS, MW, MZ, NA, SD, SL, SZ, TZ, UG, ZM, ZW), Eurasian (AM, AZ, BY, KG, KZ, MD, RU, TJ, TM), European (AT, BE, BG, CH, CY, CZ, DE, DK, EE, ES, FI, FR, GB, GR, HR, HU, IE, IS, IT, LT, LU, LV, MC, MK, MT, NL, NO, PL, PT, RO, SE, SI, SK, TR), OAPI (BF, BJ, CF, CG, CI, CM, GA, GN, GQ, GW, ML, MR, NE, SN, TD, TG).

Published:
— with international search report (Art. 21(3))

(54) **Title:** CONNECTOR WITH TPA POSITION DETECTION

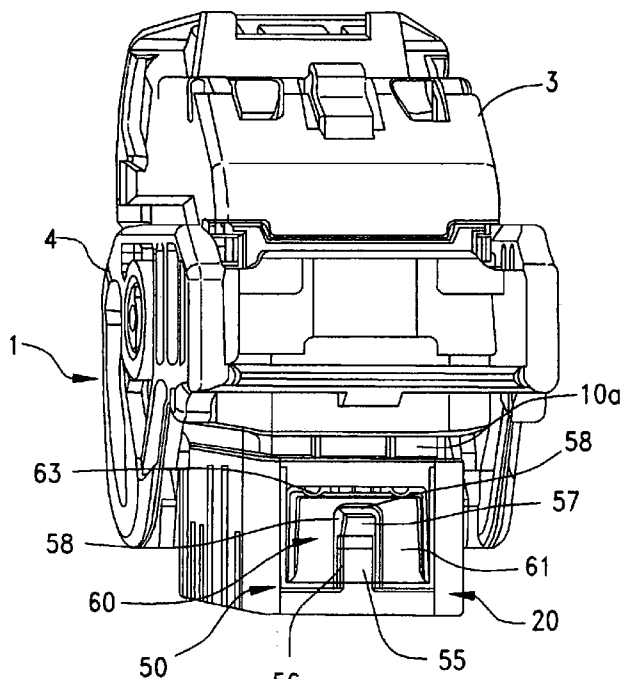

FIG. 1

(57) **Abstract:** A connector with a TPA member for locking the latching elements of the terminals. When one of the terminals is not in its fully inserted position, the TPA member is prevented from reaching its final position which is detected by TPA position detecting means that prevents mating of the connector with the complementary connector.

WO 2009/131860 A1

CONNECTOR WITH TPA POSITION DETECTION

Field of the Invention

The invention relates to a connector that is mateable with a complementary connector and comprises a connector housing, a plurality of terminals and a TPA member
5 for terminal position assurance, and particularly to a connector wherein the terminals are latched in cavities of the connector housing and, when in a fully inserted position, can be locked by the TPA member. Connectors with the terminal position assurance feature are widely used in the automotive sector.

Background of the Invention

Connectors are often delivered in a so-called pre-assembled condition to customers, i.e. the terminals are not fully inserted in the cavities of the connector housing. For final use, it is important that the terminals are fully inserted to be properly seated in their respective cavity formation and that improper seating can be detected easily by the
15 customer.

An electrical connector showing this feature is known from US-A-4,544,220. The connector housing is formed with a front housing part and a backward retainer housing part for the several terminals, the latter having engaging fingers situated radially about passages which the terminals extend through. Each terminal has a notch as a seating
20 portion for the engaging fingers of the retainer housing part and a bearing portion of thicker cross section where the engaging fingers are spread apart when the terminals are inserted into the retainer housing part. If a single terminal is not fully inserted into the retainer, the engaging fingers around the respective passage remain spread apart which can be detected when assembling the connector front housing part which acts as a TPA
25 member and has openings fitting around the engaging fingers when the same engage the seating portions of the terminals. Therefore, if one of the terminals is not properly seated, the front housing part cannot be properly latched with the retainer housing part. Whereas coupling of the connector with the complementary connector is prevented when any of the terminals is not fully inserted in the connector housing, the bearing sections which
30 form beads around the terminals do not allow a small pitch in the arrangement of the terminals, that is, such a connector does not lend itself for miniaturization.

Female connectors each with a secondary lock are known from US 4,944,688 and US 4,973,268. The terminals each have a notch wherein latches of the connector housing

may engage to fix the terminals in their fully inserted positions. The secondary lock has diamond-shaped pockets formed by diagonal wall sections that can lock the latches, if the terminals are correctly seated. If one of the terminals is not fully inserted, the corresponding latch is deflected and forms a stop for the secondary lock that cannot reach
5 its final position. However, a complementary male connector may be mechanically coupled to the secondary lock of the female connector where correct electrical mating of the terminals is not ensured when the secondary lock is not fully inserted. A request exists that connectors should be prevented from being coupled when one of the terminals is not properly seated.

10 A connector having a TPA member is known from EP 0 967 694 A2 and comprises a receptacle connector housing having cantilever latch beams to latch respective terminals in the terminal cavities of the housing, if fully inserted. Otherwise the corresponding latch is flexed outwardly, and the TPA member having support ribs will engage the respective protruding latch and prevent complete insertion of the TPA
15 member. The customer must take care whether this happened, or not, since there is no automatic TPA position detecting means inherent in the construction of the connector. In detail, there is no stop to prevent mechanical coupling of the complementary plug connector on the receptacle connector that has its TPA member not fully inserted. Incomplete insertion of the TPA member will lead to missing contact of the terminals of
20 plug and receptacle connectors.

A connector with a locking TPA member according to the preamble of claim 1 is known from WO 2006/034865 A1. The connector housing comprises a contact carrier module having slot-like cavity formations with recesses to accommodate respective terminals, and latching elements for latching the terminals. The TPA member is a cap that
25 has webs in its interior to enter into the slot-like cavity formations of the connector housing so as to lock the terminals. The TPA member can be properly latched on the connector housing, if all terminals are fully inserted in the contact carrier module and are latched by the latching elements. In order to detect proper seating of the terminals, the TPA member is provided with a double-armed lever having a stop lever arm, the position
30 thereof depends from the latch-position of the TPA member, if preassembled or final assembled. If one of the terminals is not corrected seated, the TPA member cannot be properly latched in the final position, onto the contact carrier module or connector housing, and the stop lever arm forms a stop that precludes mating of the complementary connector. When all terminals are fully inserted in the connector housing, the stop lever

arm of the TPA member can take a depressed position and the TPA member can be latched on the connector housing in the final position, and the connectors can be mated.

A further connector with a locking TPA member is known from WO 2006/108610 A1. The connector housing forms slot-like cavities with terminal receiving chambers, each including a pawl for latching behind a stop on the terminal, and a guiding wall with a raising slope for pushing the terminal against the pawl, when the terminal is inserted in the housing. The TPA member is of box-like construction and includes locking lugs for blocking the respective pawls, once the connector is assembled. There is no TPA position detecting means that forms a stop for preventing mating of connectors that are not correctly assembled.

A still further connector with a locking TPA member is known from FR 2,866,485 comprising a connector housing and a TPA member. The housing has terminal passages provided with pawls for latching the terminals, and the TPA member has fingers to block the pawls when the connector is completely assembled. No TPA position detecting means is provided.

A miniaturized connector is known (EP 1 351 339 A1) comprising a housing with six terminals in two rows, and a cap-shaped retainer with wall portions acting as a TPA member. The retainer has a front wall with six terminal openings and, associated thereto, six jig insertion holes for forcibly resiliently deforming the locking portion of a respective terminal. No probe access opening is provided.

A connector is known (EP 1 753 091 A1) that comprises a connector housing having terminal cavities with latching portions for the terminals, a retainer for locking the terminals and a front mask having terminal insertion openings and jig insertion openings. The front mask can be positioned in a proper position wherein the terminal insertion openings register to the terminal cavities, and shifted transversely to the terminal extending direction into a test position wherein the terminal insertion openings can be used as test openings. The retainer is inserted into a housing opening that extends transversely to the terminal extending direction and is therefore different to a TPA member of box-like construction.

A divided connector is known from EP-A-1 220 371 having resilient locking members. A detecting probe is provided for checking whether the terminals have reached their fully inserted positions.

A connector comprising a housing with cavities and terminal fittings as well as a retainer with terminal insertion openings and jig insertion openings is known from US

2002/187676 A1. A jig is insertable into the jig insertion openings to unlock the locks of the terminals.

Summary of the Invention

5 It is an object of the invention to construct a connector of the kind specified that allows a small pitch distance between the terminals.

 It is another object of the invention to provide a connector of the kind specified with TPA position detecting means indicating whether, or not, the TPA member is correctly positioned on the connector.

10 It is a further object of the invention to provide means that prevents mating of the connectors, when the TPA member is not correctly positioned.

 It is still a further object of the invention to provide a connector of the kind specified that can be mated with the complementary connector without any interference by TPA position detecting means when the connector has been correctly assembled.

15 It is still a further object of the invention to provide a connector of the kind specified that, in an assembled condition of the connector, forms compartments that firmly hold and retain the terminals, even if heavy vibrations occur.

 It is still a further object of the invention to provide a connector of the kind specified that, in case of incomplete insertion of a terminal, does not suffer from an
20 incorrect assembly of the TPA member, even if an excessive force is applied onto the TPA member.

 It is still a further object of the invention to provide a connector of the kind specified that provides connectors comprising probe access openings and extraction tool openings separate from the terminal openings.

25 It is still a further object of the invention to provide a connector of the kind specified that is of a simple design.

 It is still a further object of the invention of the kind specified that can be tested by a probe tool.

30 It is still a further object of the invention of the kind specified that allows to unlock and unlatch the terminals, if desired.

 The invention is defined in the claims.

 The connector of invention includes a connector housing, a plurality of terminals and a TPA member for terminal position assurance. The connector housing includes a plurality of cavity formations, each for receiving a respective one of the terminals. Each

cavity formation has a latching element for latching a respective one of the terminals in a fully inserted position. The TPA member includes blocking elements which, in a final position of the TPA member, cooperate with the latching elements so as to lock the terminals which are in fully inserted positions, and when at least one of the terminals is not in its fully inserted position, the respective latching element cooperates with the TPA member so as to prevent the TPA member from reaching its final position. The connector also includes TPA position detecting means that forms a stop that prevents mechanical coupling of the connector with the complementary connector when the TPA member did not reach its final position.

10 According to the invention, the TPA position detecting means comprises guiding means on the connector housing and at least one spring finger with a stop member on the TPA member. In order to cooperate with the guiding means on the connector housing, each spring finger has at least one boss so as to guide the respective spring finger with its stop member from a stopping position wherein the stop prevents mating, to a final
15 position wherein the stop member is in a unblocking position and mating of the connectors is made possible. Though the connector of invention has a TPA position detecting means, in the case of all terminals have been correctly seated in the connector housing, no interference is met when coupling the connectors together. The connectors can be mated with the usual force on the field of connectors.

20 In a preferred embodiment of the invention, the TPA member is of box-like construction having a hollow in it for encompassing a block-like portion of the connector housing, wherein the terminals are seated. Thus, the TPA member has a frontside wall with openings for male terminals of the complementary connector, a first pair of (larger) lateral sidewalls, a second pair of (smaller) lateral sidewalls, and an open side leading to
25 the hollow for assembly on the connector housing. According to this embodiment of the invention, each sidewall of the second pair of sidewalls has a slot that defines the outlines of a respective spring finger, with a pair of bosses extending into the slot. Thus, the TPA position detecting means is of simple construction: On the side of the TPA member, the TPA position detecting means is made up from wall portions of the TPA member, and on
30 the side of the connector housing, the TPA position detecting means is formed by ribs having an undercut portion, so as to form a guiding groove for the bosses of the spring fingers. At the entry of the guiding groove, a cam is provided that defines the stopping position of the TPA member.

Brief Description of the Drawings

Preferred embodiments are described with reference to the accompanying drawings.

Fig. 1 is a perspective view onto a small lateral side of a connector of invention,

5 Fig. 2 is a perspective view onto a large lateral side of the connector of Fig. 1 in mated condition with a complementary connector,

Fig. 3 is an enlarged view onto guiding means formed on a lower portion of the small lateral side of the connector housing of Fig. 1,

10 Fig. 4 is an enlarged section through a detail in Fig. 2 in a condition of preventing the mating of connectors,

Fig. 5 is a similar view to Fig. 4 for a condition of assembling the TPA member onto the connector housing,

Fig. 6 is a similar view to Fig. 4 for the condition of mating two connectors,

15 Fig. 7 is a part-sectional view through a connector housing showing the insertion of terminals in respective cavities,

Fig. 8 is a similar view to Fig. 7 with all terminals seated in their fully inserted positions,

Fig. 9 is a similar view to Fig. 7 with a TPA member in its locking position,

Fig. 10 is a perspective view onto the underside of the connector housing,

20 Fig. 11 is a perspective view onto the underside of a box-like TPA member,

Fig. 12 is a perspective view into the hollow of the box-like TPA member,

Fig. 13 is an enlarged detail from the interior of the connector showing terminal insertion,

Fig. 14 is a similar view to Fig. 13 showing latching of a terminal,

25 Fig. 15 shows latching of a terminal with a changed view of Fig. 14,

Fig. 16 is a part-sectional view through the connector housing with an extraction tool in action; and

Fig. 17 is an enlarged detail of Fig. 11.

30 Detailed Description

Figs. 1 and 2 show a connector assembly for automotive applications. The assembly includes a first or female connector 1 and a second or male connector 2 complementary to the first connector 1. Connector 1 includes a main housing 10, a TPA member 20 for terminal position assurance, a wire cap 3, a lever 4 and a peripheral seal 5

(Fig. 7). A plurality of conductors 30 (Figs. 7, 8, 9) extend through a seal cover and a
matt seal (not shown) into the connector housing 10 and are terminated with receptacle
terminals 31. These terminals 31 can be mated with plug terminals 6, 7 of the male
connector 2 (Fig. 2). To that end, the lever 4 is provided with a slot 40, and the housing of
5 the second connector 2 is provided with a peg 41 which, when the lever 4 is pivoted,
cooperate to draw the second connector 2 relative to the first connector 1 and bring the
terminals of both connectors together. However, such mating is only possible, if all of the
terminals 31 are properly seated in the connector housing 10.

As best shown in Fig. 10, the connector housing 10 has a slotted front part 10a so
10 as to form parallel walls 15. In the embodiment shown, two outer walls 15 and two inner
walls 15 are provided. One side of each wall 15 comprises recesses 16 to accommodate
the terminals 31 whereas the other side is „empty“. The recesses 16 are separated from
one another by webs extending in inserting direction of the terminals 31 and form cavity
15 formations for these terminals. Empty sides face to one another separated by slots 17. All
slots in the front part 10a are limited by lateral outer walls 18. The recesses 16 of the
middle pair of walls 15 face to one another and include a middle or central cavity 11C,
whereas outer cavities 11A, 11B are formed between the outer walls 15 and outer walls
23 of the TPA member 20. The cavities 11A, 11B and 11C are provided with latching
elements 12 that are set back relative to the free ends of the walls 15.

20 Figs. 7 through 10 show how the terminals 31 are mounted in the recesses 16 of
the slot-like cavities 11 of the connector housing part 10a to be enclosed therein. The
terminals 31a at the right-hand side in Fig. 7 are about to be shifted into their rest
positions which the left-hand side terminals 31 have already reached. As shown, the
terminals 31a slide along straight wall surfaces of the recesses 16 that are parallel to one
25 another and to the insertion or mounting direction of the terminals 31. On the other hand,
the latching elements 12 extend into the space of the recesses 16 and are bent back when
the terminals are inserted as at 12a in Fig. 7. When the terminals 31 reach their fully
inserted positions, the latching elements 12 snap behind respective shoulders 32 of the
terminals 31 so as to fix the terminals in their final positions.

30 The terminals 31 are of channel-like configuration with a U-shaped cross-section
(see Figs. 13, 14), i. e. have side legs 31c, 31d and a connecting leg 31e. One end - the
upper end in Figs. 7-9 and 15 - is fixed to a conductor or cable of a cable harness 30 such
as by crimping. (In Figs. 13, 14, the crimping parts for the conductor are omitted for
reasons of showing the U-shaped cross-section.) Within the channel of each terminal 31,

a contact portion is provided for the respective plug terminal 6 or 7 of the male connector 2. In the embodiment shown, four rows of terminals 31 and three cavities 11A, 11B and 11C are formed. The female terminals 31 form a group A for mating with the male terminals 7 and a group B for mating with the terminals 6 of the complementary connector 2 (Fig. 2). The A group contains ten terminals of smaller type in four rows and the B group two terminals also in four rows. Please note that the cavities 11 are not interrupted by any cross web, and encompass each a plurality of terminals 31. Furthermore, there is no slot separating group A from group B. The latch elements 12 are arranged in rows corresponding to the arrangement and size of the terminals 31 of the groups A and B.

As best shown in Figs. 13-16, each terminal 31 has a shoulder 32 that is formed by tabs from side legs 31c, 31d of the terminal wall. The tabs are bent to form a bridge crossing the channel of the respective terminal 31, that is, wall portions of the terminal form a closed profile at that place. Terminal 31a in Fig. 7 and Figs. 13-15 is about to be inserted into its cavity 11 and by doing so deflects the latching element 12a, which slides over the closed profile at the shoulder 32. When the terminal 31a is further inserted in its cavity 11, that is, shifted downwardly in Fig. 7, the respective latching element 12a snaps behind the shoulder 32 of the respective terminal 31a and fix it to some degree. This is done by the lowermost surface of the latching element 12, or as shown in Figs. 13, 14, by recess surfaces 12r at the free end of each latching element 12.

For the environment in an automotive vehicle, fixation by the latching elements 12 is not deemed sufficient, therefore the TPA member 20 is provided to lock the latching elements 12. The TPA member 20 includes blocking elements 21 which have the form of a web, as shown in Figs. 12 through 15. When a terminal such as 31a is not fully inserted in its cavity, and the latching element 12a is deflected, the blocking element 21 will meet the latching element 12a when trying to fully assemble the TPA member 20 onto the connector housing 10, as is demonstrated in Fig. 7. If however the terminals 31 take their fully inserted positions, as shown in Fig. 8, there is a narrow space 13 behind each latching element 12 wide enough to accommodate the free end of a respective blocking element 21 when the TPA member 20 is shifted into its final position as shown in Fig. 9. The blocking elements 21 are effective to lock the latching elements 12 and, therefore, also the terminals 31 in their respective fully inserted positions.

In the case of an automotive application of the connector, the TPA member 20 is preferably of box-like construction, as shown in Figs. 1, 11 and 12. As such, it has a

bottom or frontside wall 22, a first pair of longer lateral sidewalls 23, a second pair of shorter lateral sidewalls 24 and an open side leading to the hollow interior 25 of the TPA member 20. The blocking elements 21 are arranged in rows 21A, 21B and 21C in the hollow interior 25 of the box-like TPA member and form webs or walls as best shown in Fig. 12. The length of each row or wall 21A, 21B or 21C measured between the shorter sidewalls 24 corresponds to a respective cavity 11A, 11B or 11C. In the area for the male terminals 7, the blocking elements include each a rib 26 and a fin 27, that extend in insertion direction of the terminals. Therefore, the ribs and fins 26, 27 function as a guide for the lateral sides 31c, 31d of the U-shaped terminals 31, particularly the rims thereof, when the TPA member 20 is shifted onto the housing block 10a.

At the level of the shoulder 32, the terminal 31 is of closed profile, so that the latching element 12b in Fig. 13 can slide over a flat surface of the terminal 31b at the shoulder 32 when the terminal 31b is moved into its fully inserted position. The latching elements 12 facing one another for the middle cavity 11C as shown in Figs. 13 and 14 are shaped rotary symmetric to one another and include each a wing 14 for sliding engagement with the outer wall of a respective terminal 31 in the region of the shoulder 32. This construction of the latching elements 12 and the blocking elements 21 with the guiding ribs 26 and fins 27 allow firm holding of the terminals 31 in the cavities 11 of the housing 10 where each cavity 11 is common for all terminals in a row.

The middle or central row 21C of blocking elements 21 show the ribs 26 staggered from one to the other side of the web formed by the blocking elements. Furthermore, the upper end surfaces 26a of the ribs 26 are inclined to one another in V-shape as best seen in Figs. 13-15. When a latching element 12a is deflected by virtue of a terminal 31a not being fully inserted, as shown in Figs. 7, 14 and 15, it takes a stop position with its blocking element 21, and the associated rib 26 with its inclined end surface 26a offers a further stop surface so that the latching element 12a cannot slip beyond the element 21 when the TPA member 20 is pressed upwardly in Figs. 7 and 14, 15. Furthermore, the ribs 26 and fins 27 form holding surfaces for the legs 31c, 31d of the terminals 31 which are basically U-shaped in cross section. The slots between the ribs 26 and the fins 27 are useful to fix the legs 31c, 31d of the U-shaped terminals 31. For the middle row 21C of blocking elements 21, there are two rows of terminals 31 and two rows of latching elements 12.

The connector housing part 10a may be of a block-like construction (Fig. 10) that is made up of $2n$ parallel walls 15 ($n = 1, 2, 3 \dots$). Each wall 15 is provided with a number

of recesses 16 for accommodating respective terminals 31. The outer walls 15 are facing the respective inner sides of the larger lateral walls 23 of the TPA member, when the connector 1 has been assembled. The inner walls 15 are facing one another and include the (or each) middle cavity 11. Each outer wall 15 is facing one inner wall 15 to include a narrow empty space 17 therebetween for purpose of material savings and guiding ribs 22a of the TPA member 20 (Figs. 7-9). This construction allows dense packaging of the terminals 31 with no cross-extending walls of the main housing 10 between adjacent terminals in a row.

As was explained in the preceding description, the TPA member 20 may take a final position as shown in Fig. 9, when all terminals 31 are fully inserted, and an intermediate position, when anyone (31a) of the terminals is not fully inserted (Fig. 7). The connector of invention includes TPA position detecting means 50 that is explained with the help of Figs. 3 through 6 and 10 through 12. The TPA position detecting means 50 is made up of two main components, namely guiding means 51 (Figs. 3-6) on each small lateral side of the connector housing part 10a, and each a spring finger 55 (Figs. 1, 4, 5, 6, 11, 12) formed on each small lateral side 24 of the TPA member 20. Guiding means 51 include a pair of parallel ribs 52 that extend along the small lateral side 18 of the connector housing part 10a, each having an undercut 52a facing one another so as to form a guiding groove 53 therebetween. At the entry side of the groove 53, a cam 54 is provided. The spring finger 55 is part of the TPA member 20 and made up from wall portions of the smaller lateral side 24 (Figs. 1, 11 and 12). An U-shaped slot 56 in the wall of the box-shaped TPA member 20 separates the spring finger 55 from the TPA member wall leaving a bridge that connects the spring finger with the TPA member wall. The spring finger 55 is provided with a stop element 57 and a pair of bosses 58 that extend into the slot 56. At the level of the bosses 58, the width of the spring finger corresponds to the width w of the groove 53 (Fig. 3). The bosses 58 may slip into and along the respective slots offered by the undercut portions 52a.

In the intermediate position of the TPA member 20 (Figs. 7 and 8), the spring finger 55 takes a position shown in Fig. 4, that is, the inner body surface of the spring finger 55 rests upon the cam 54, and the bosses 58 are clear off the slots 52a. In this situation, the stop element 57 prevents shifting of the connector 2 into its mating position. Thus, the spring finger 57 „detects“ the TPA intermediate position and, therefore, a terminal 31a not fully inserted.

When the terminals 31 are fully inserted, as shown in Fig. 8, the TPA member 20 can be moved into its final position. Fig. 5 shows the start of this movement. The spring finger 55 has an inward bias so that the bosses 58 enter into the groove 53, and the spring fingers 55 are bent inwardly. With the further movement of the TPA member 20, the bosses 58 get into the slots 52a as shown in Fig. 6. The spring fingers 55 are fully bent inwardly when the TPA member 20 reaches its final position. As shown, the stop element 57 is fully retracted and does not offer any interference to the second complementary connector 2 when the same is mated with the first connector 1.

TPA latching means 60 are provided on the TPA member 20 and the connector housing part 10a, respectively, to latch the TPA member in its final position onto the connector housing 10. The TPA latching means 60 include each a flexible tongue 61 provided with dogs 62 (Fig. 12) on the TPA member and catches 65 (Fig. 3) on the smaller lateral side 18 of the connector housing part 10a. The latching tongue 61 is made up from wall portions of the TPA member 20, separated from the main wall portions by a slot 63. When the TPA member 20 is shifted into its final position, the dogs 62 snap behind the catches 65, and the TPA member is latched onto the connector housing portion 10a.

As shown in Figs. 11, 16 and 17, the front wall 22 of the TPA member 20 is provided with a number of openings, among them openings 71A for the passage of the male terminals 7, opening 71B for the male terminals 6, openings 72 for terminal probing and openings 73 for an extraction tool 75. The openings 71A, 71B, 72 and 73 do not merge with one another. The openings 71A register to the recesses 16 for the female terminals 31 of group A and the openings 71B register to the recesses for the group B terminals. Similarly, the openings 72 register to an outer wall of each respective terminal 31 (see Fig. 9) and openings 73 register along an outer slide surface of each respective terminal 31 (see Fig. 16). Size and shape of the openings 71A, 71B, 72 and 73 are made different to one another in order to avoid mistakes when mating connectors or using the probe or the extraction tool. Particularly, the openings 73 have a basically triangular shape or L- or T-shape with one side larger than the sides of the square openings 71A or 71B, or the diameter of the circular probe openings 72. Accordingly, the cross-sectional dimensions of the extraction tool 75 are bigger than the dimensions of the passages 71A for the male terminals 7. The terminals 31 are shaped and arranged such that electrical terminal probing can be done through openings 72 without touching the contact portion of the terminal, which is inside the legs 31c, 31d of a respective terminal 31. Similarly,

when the TPA member 20 is pulled into the position shown in Fig. 8, where the spaces 13 are clear from the blocking elements 21, the extraction tool 75 (Fig. 16) lifts the latch 12 without touching the terminal contact area of terminal 31 as best seen in Fig. 16.

5 Thereupon, the terminal so unlatched can be extracted by pulling on the appropriate terminal conductor or by pushing onto the appropriate terminal 31.

The front wall 22 of TPA member 20 has further openings 74 (Fig. 11) for an extraction tool (not shown) for bending back the spring fingers 55 and/or the flexible tongue 61 for removing the TPA member 20 from the connector housing 10.

10 It now can be understood that the objects named in the specification introduction can be fulfilled, namely that a small pitch distance between the terminals can be kept, that correct positioning of the TPA member can be detected, that in case of incorrect positioning of the TPA member, the connectors are prevented from mating, and that in case of correct positioning of the TPA member, the connector can be mated without any interference.

15 The embodiments described can be modified without departing from the scope of the claims.

CLAIMS

1. A connector mateable with a complementary connector, comprising:
a connector housing,
5 a plurality of terminals, and
a TPA member for terminal position assurance, the connector housing including
a plurality of cavity formations, each for receiving a respective one of the
terminals,
a latching element being provided for each cavity formation for latching a
10 respective one of the terminals in a fully inserted position,
TPA latching means provided on the TPA member and the connector housing,
respectively, to latch the TPA member in its final position onto the connector housing,
the TPA member including
locking elements which, in the final position of the TPA member, cooperate with
15 the latching elements so as to lock the terminals which are in fully inserted positions, and
when at least one of the terminals is not in its fully inserted position, the
respective latching element cooperates with the TPA member so as to prevent the TPA
member from reaching its final position,
the connector also including TPA position detecting means that forms a stop that
20 prevents mating of the connectors when the TPA member is in an intermediate position,
characterized in that
the TPA latching means is arranged separated from the TPA positions detecting
means,
the TPA position detecting means comprises:
25 guiding means forming a guiding groove on the housing, and
at least one spring finger having an inward bias,
wherein the spring finger includes:
a stop element for the complementary connector and
at least one boss for cooperation with the guiding groove of the guiding means,
30 so as to guide the boss of the spring finger into and along the guiding groove, and
when a terminal is not fully inserted, the TPA member with its stop element takes a
stopping position wherein the stop element prevents mating, and
when all terminals are fully inserted, shifting of the TPA member into its final
position is possible so that the stop element is in an unblocking position so as to enable

mating of the connectors.

2. The connector of claim 1, wherein the TPA member is of box-like construction having a hollow in it and comprising a frontside wall with openings for male terminals of the complementary connector, a first pair of lateral sidewalls, a second pair of lateral sidewalls and an open side for assembly on the connector housing, each sidewall of the second pair having a slot that defines the outlines of a respective spring finger with a pair of bosses extending into each slot.

3. The connector of claim 2, wherein the connector housing has a block-like portion corresponding in shape to the hollow of the TPA member, the block-like portion on its outer side comprising a pair of parallel ribs with the guiding groove therebetween, and a cam arranged at an entry side of the guiding groove, the ribs having an undercut portion and together with the guiding groove form guideways so that the pair of bosses of each spring finger are guided along the guideways when the TPA member is shifted into its final position.

4. The connector of claim 3, wherein the cam at the entry side of the guiding groove, in cooperation with the spring finger body, defines the stopping position of the TPA member.

5. The connector of claim 1, wherein the TPA latching means include a flexible tongue provided with dogs and formed from wall portions of the TPA member, and catches on the connector housing.

6. The connector of claims 5, wherein each lateral sidewall of the second pair of lateral sidewalls comprises a second slot so as to form the flexible tongue from wall portions of the second pair of lateral sidewalls.

7. The connector of any of claims 6, wherein the frontside wall of the TPA member, close to each second pair of lateral sidewalls, comprises openings for entry of an extraction tool so as to unlatch the TPA member from engagement with the connector housing.

8. The connector of claim 1, wherein the blocking elements of the TPA member form walls comprising ribs extending therefrom, each rib having an inclined end surface facing a respective latching element for engaging the same when such latching element is deflected by virtue of a terminal not fully inserted.

5

9. The connector of claim 8, wherein the terminals are of U-shaped configuration having side legs and wherein the blocking elements comprise fins that, together with the ribs form slots therebetween to guide the side legs of the terminals in their fully inserted positions.

10

10. The connector of claim 9, wherein slot-like cavities are formed between parallel walls of the housing block-like portion and towards each lateral sidewall of the first pair of sidewalls, each wall being provided with a row of recesses for accommodating the respective terminals, and wherein the latching elements and the blocking elements extend in the slot-like cavities from opposite sides of the cavities.

15

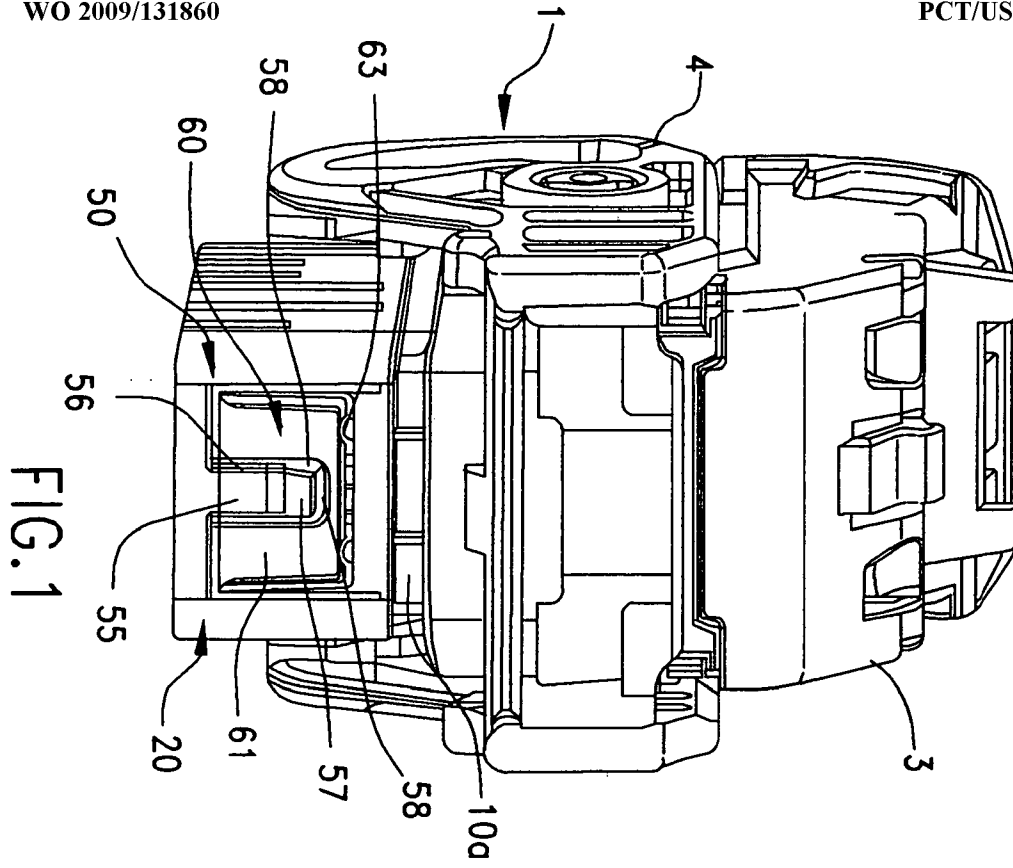

FIG. 1

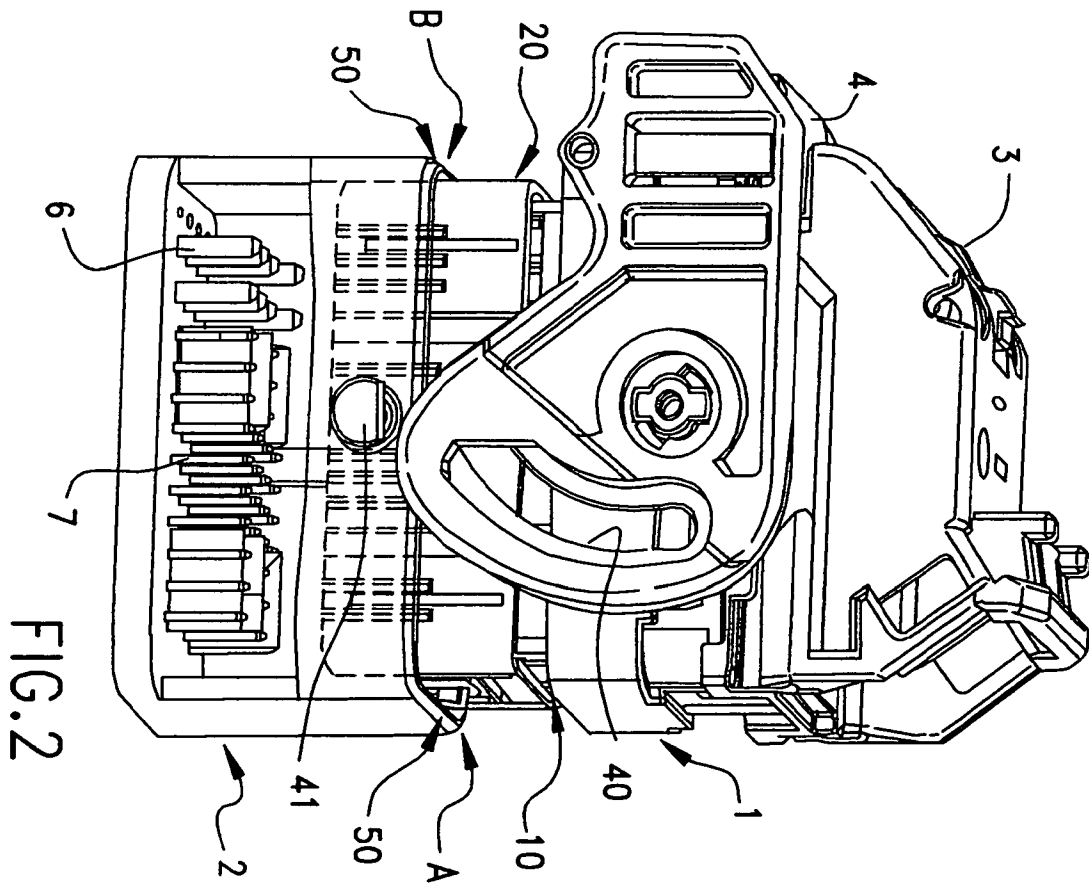
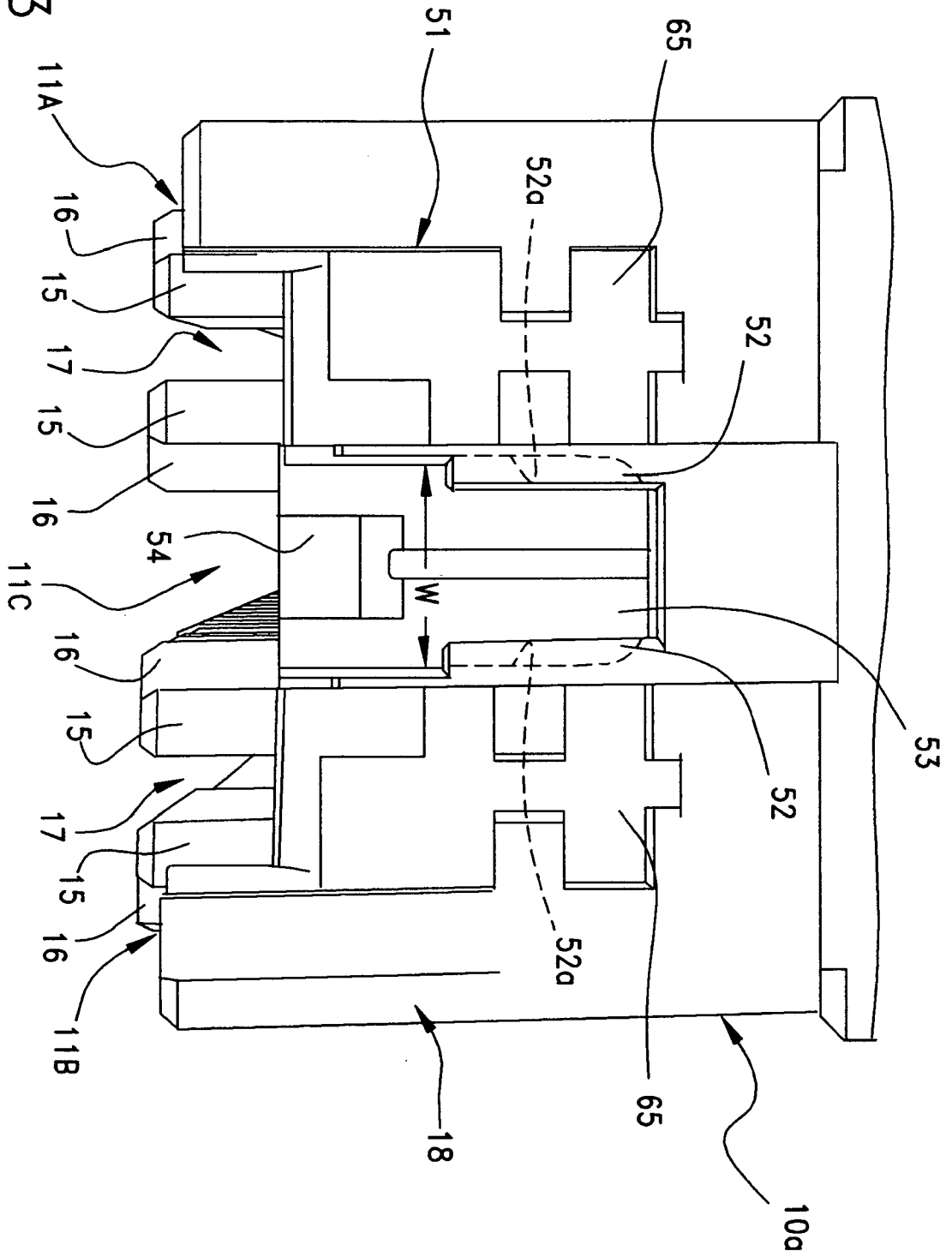

FIG. 2

1/9

FIG. 3



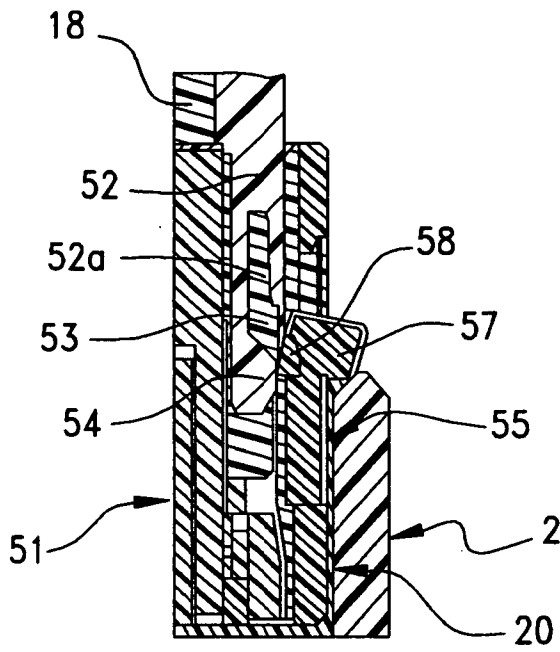

FIG. 4

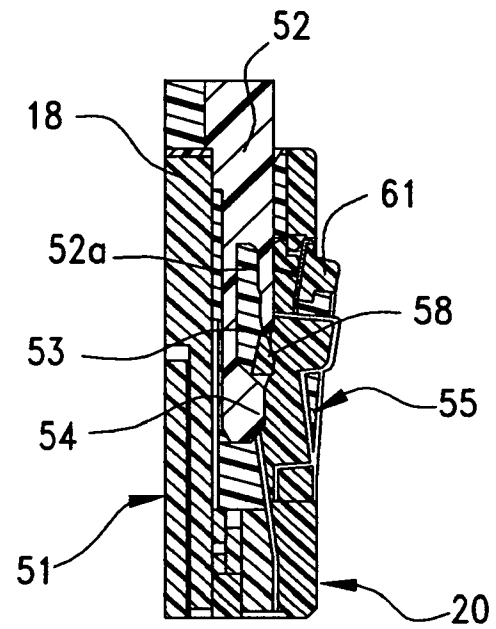

FIG. 5

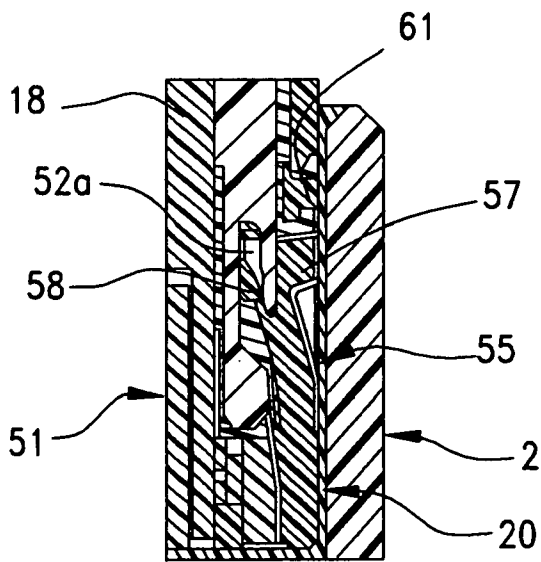

FIG. 6

4/9

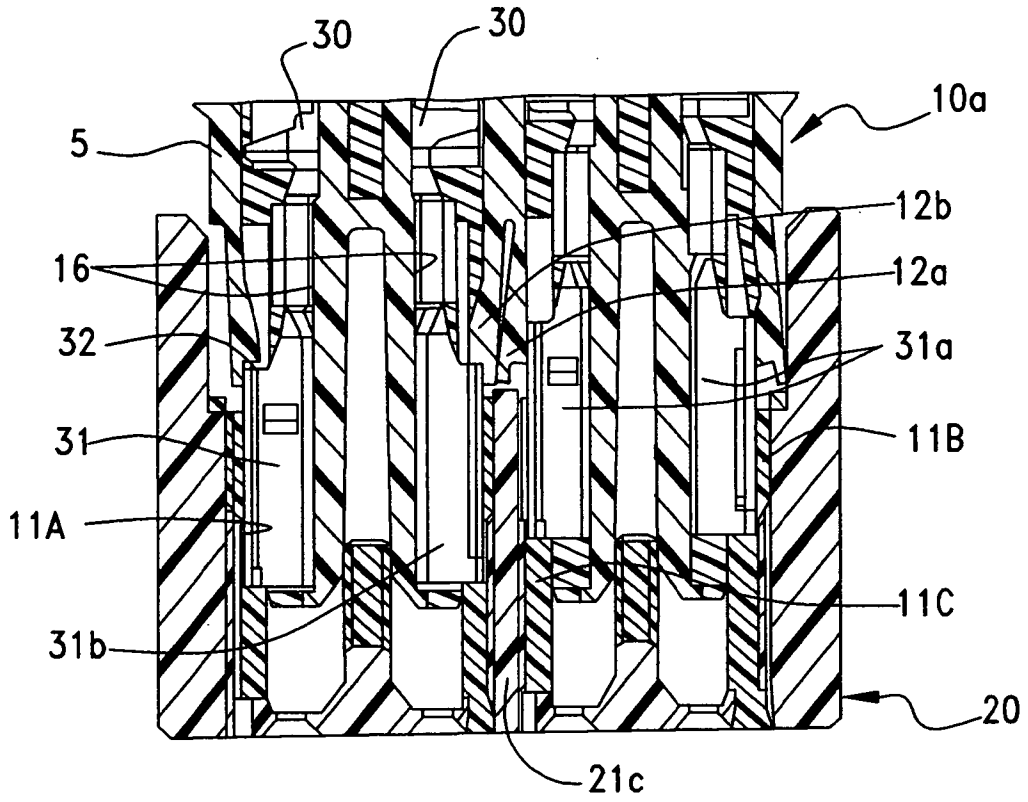

FIG. 7

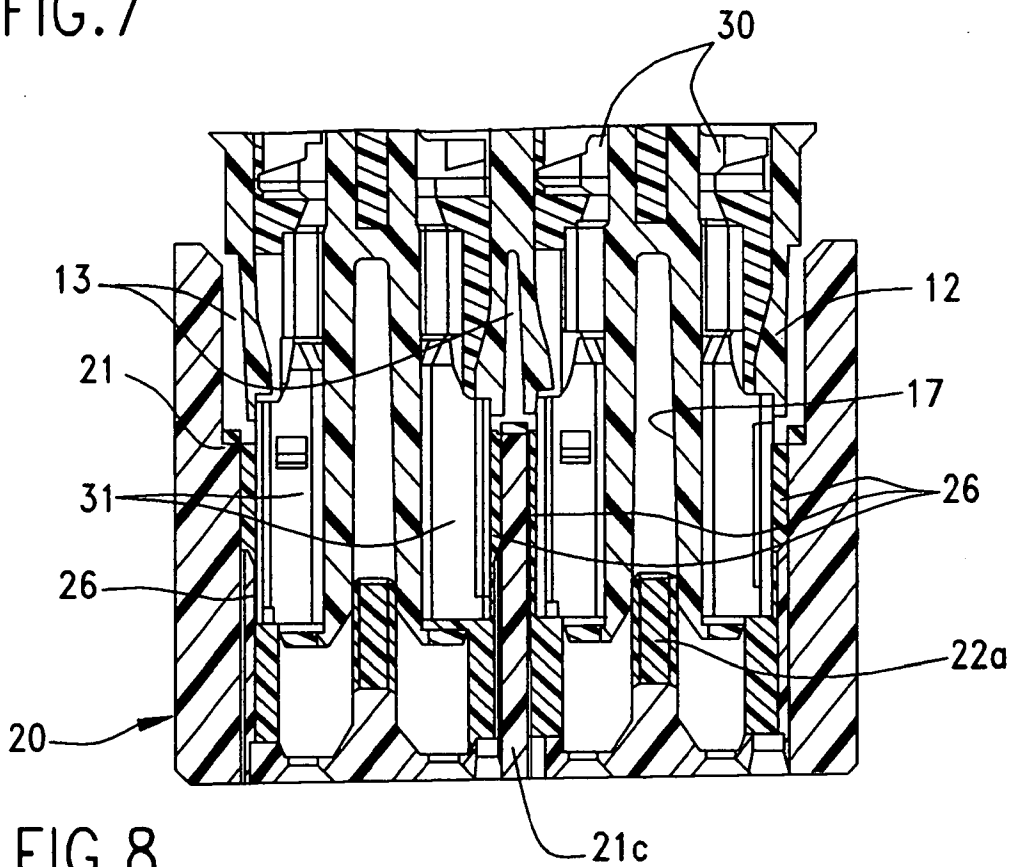
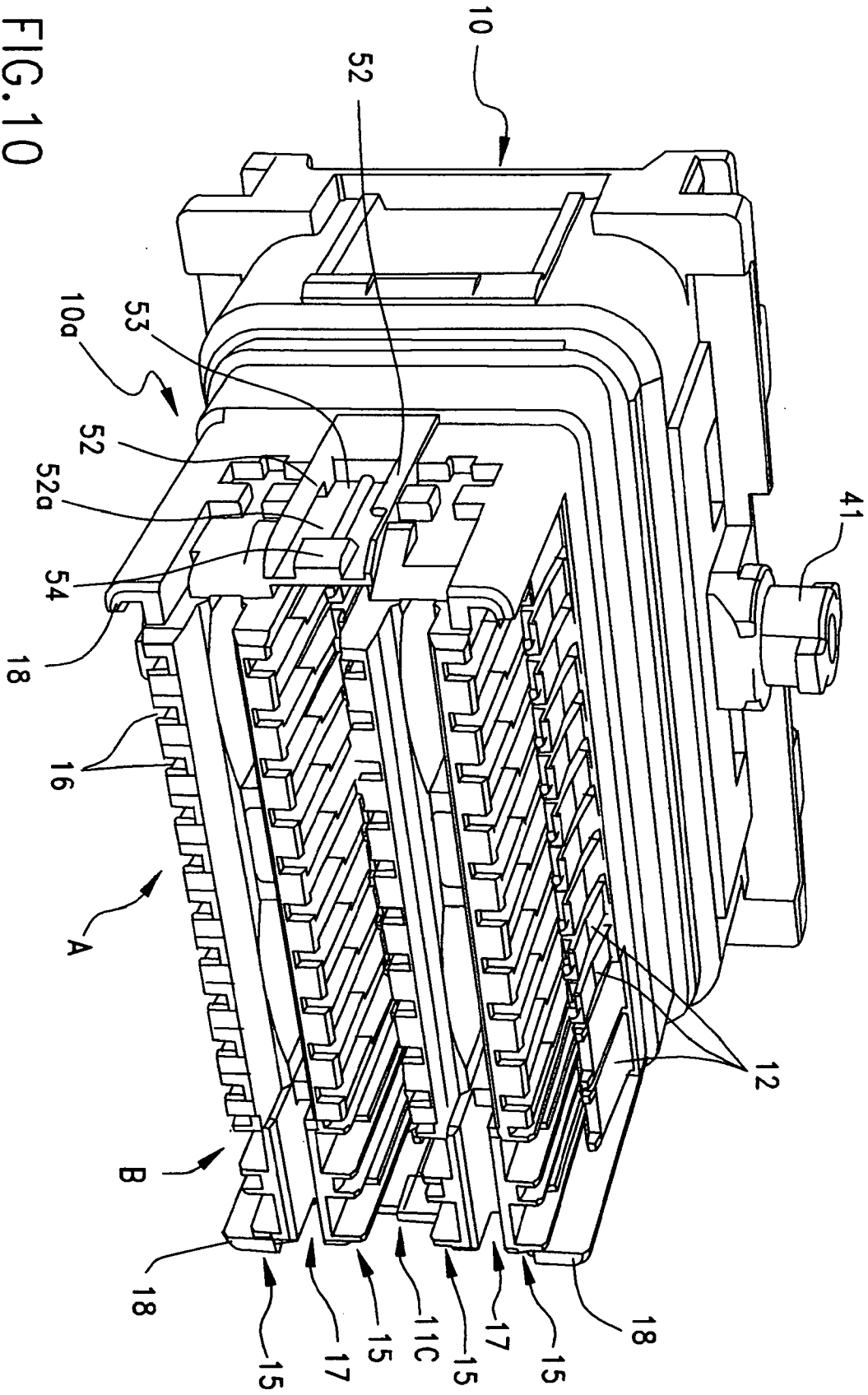

FIG. 8

FIG. 10



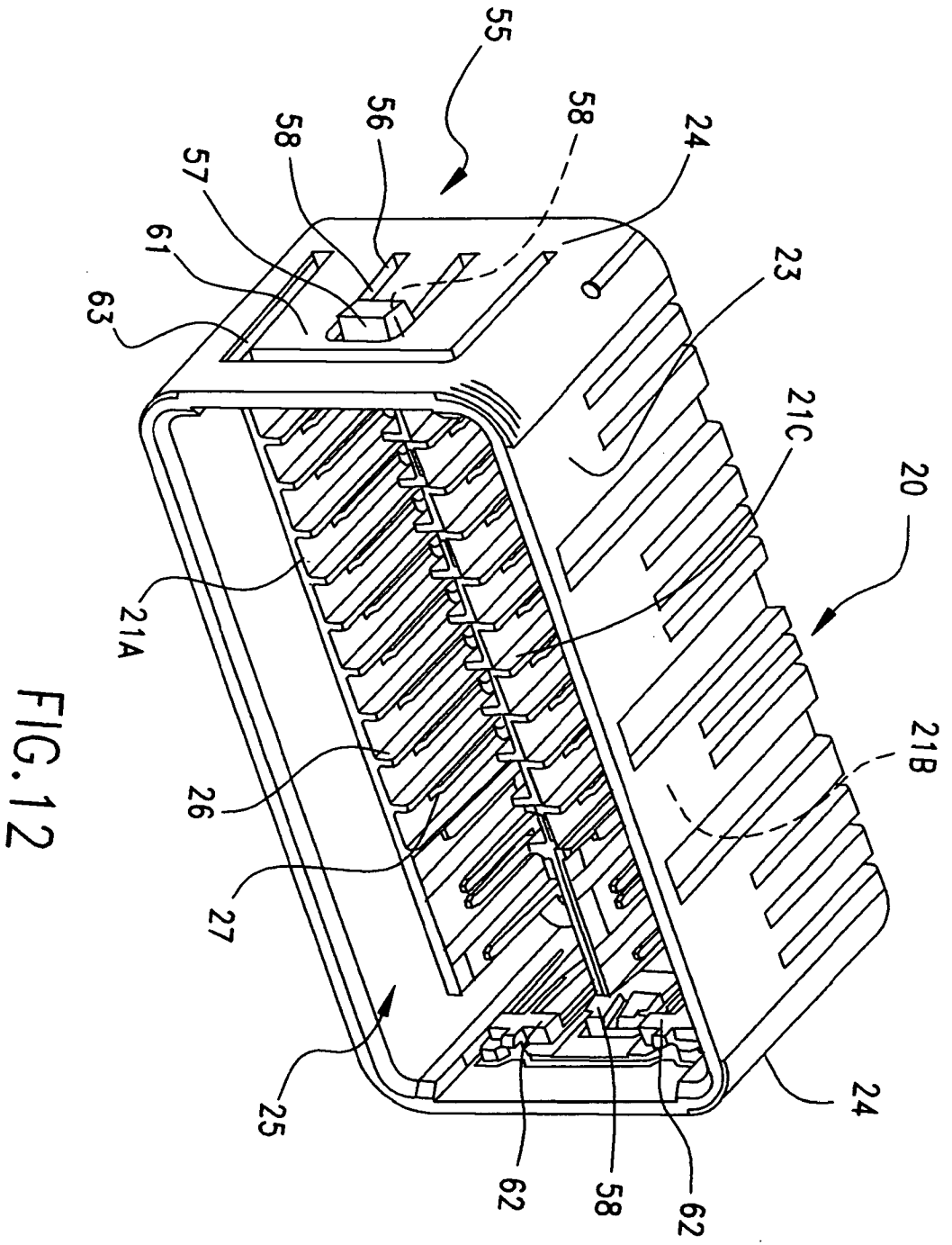

FIG. 12

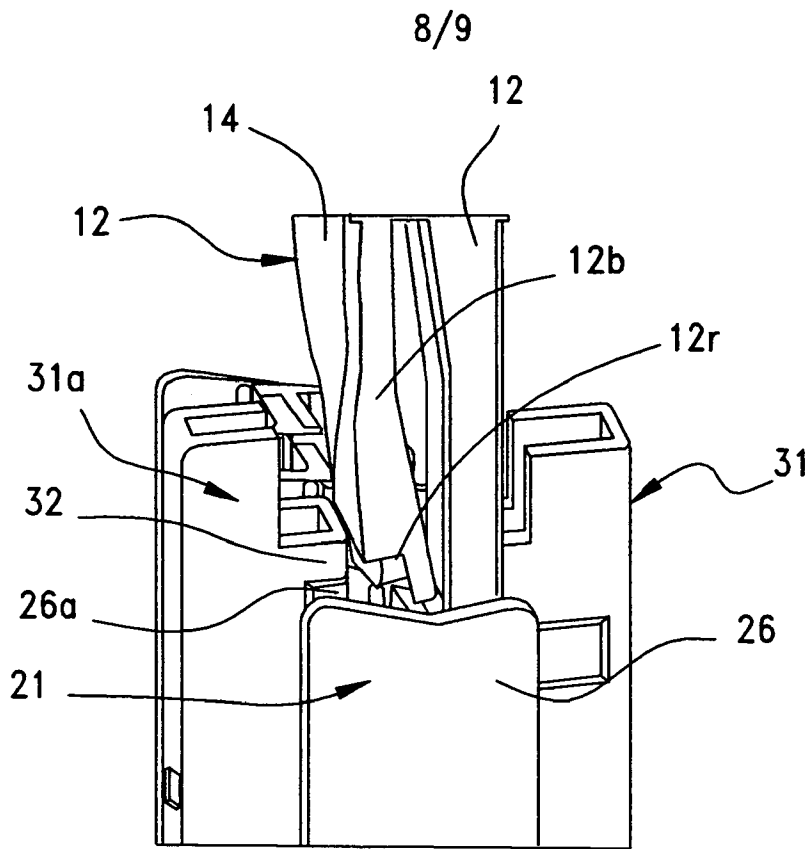

FIG. 13

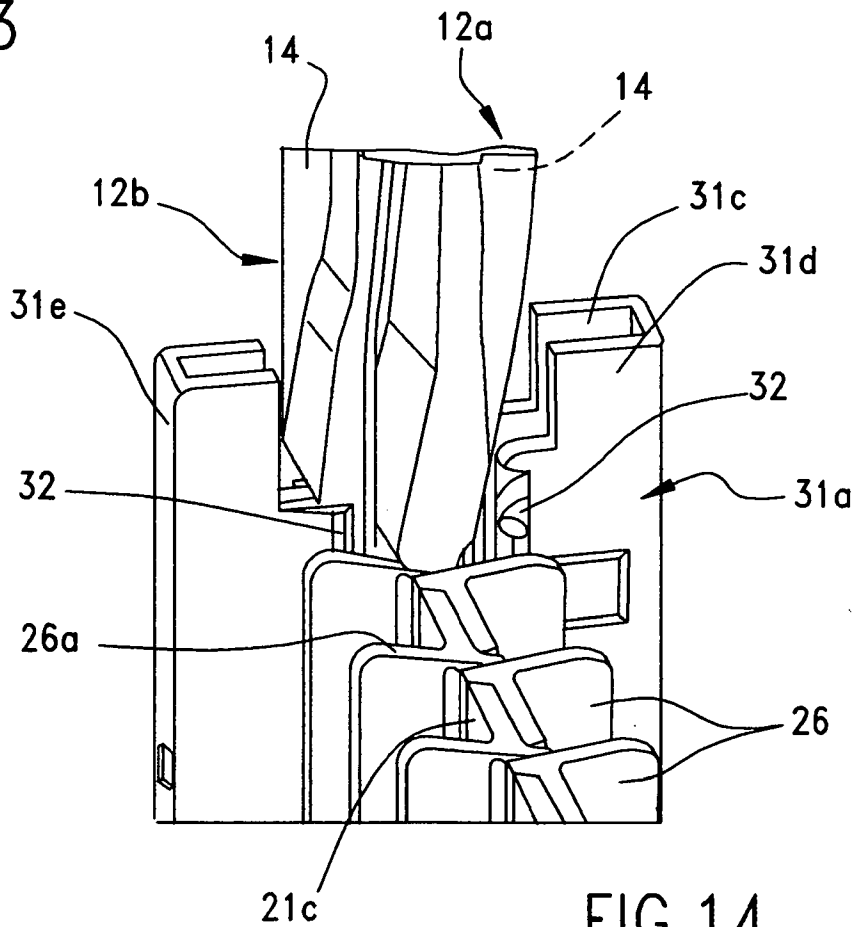

FIG. 14

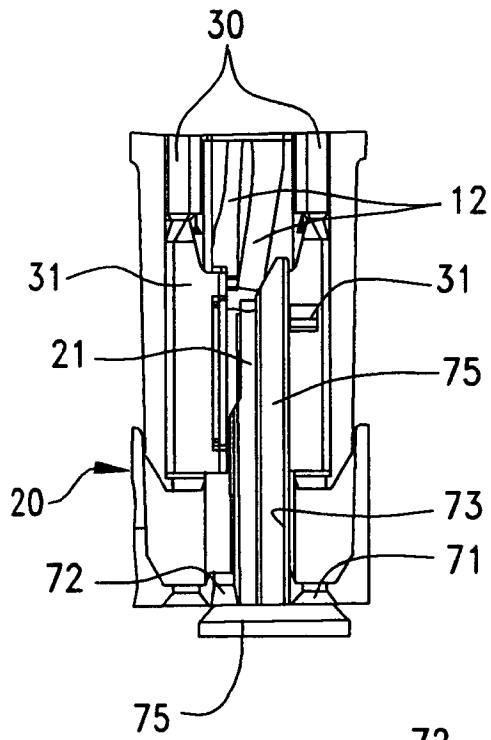
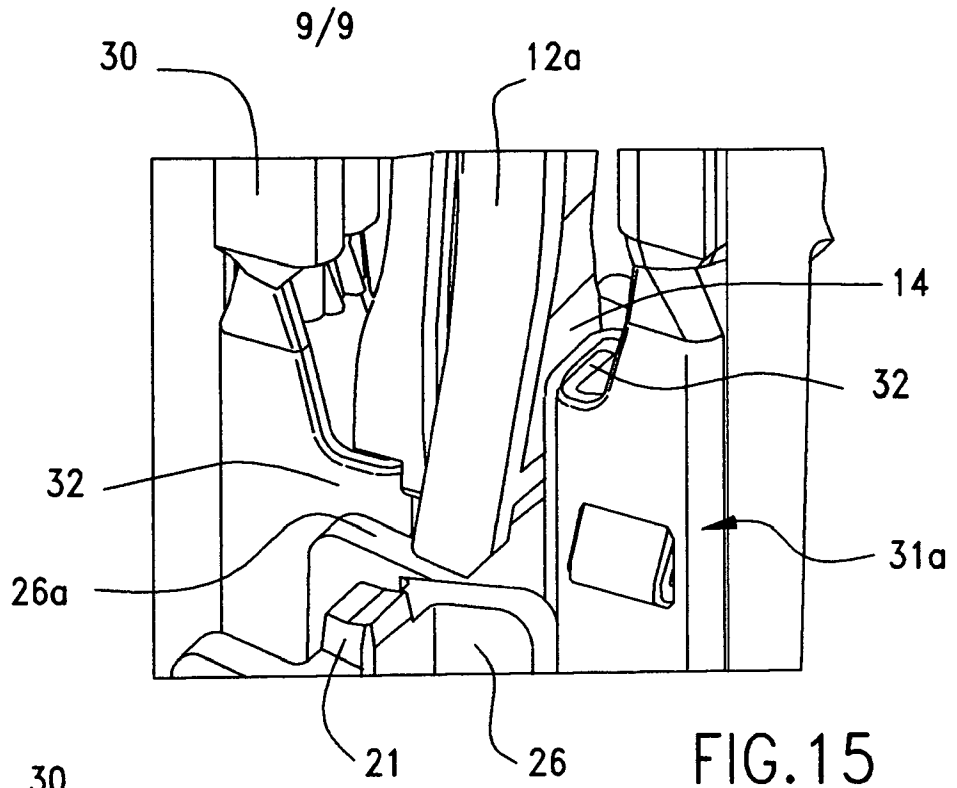
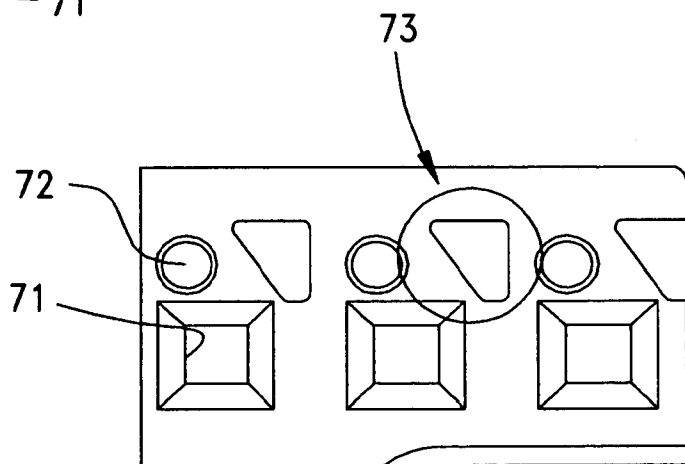

FIG. 17



INTERNATIONAL SEARCH REPORT

International application No
PCT/US2009/040356

A. CLASSIFICATION OF SUBJECT MATTER INV. H01R13/641 H01R13/436		
According to International Patent Classification (IPC) or to both national classification and IPC		
B. FIELDS SEARCHED		
Minimum documentation searched (classification system followed by classification symbols) H01R		
Documentation searched other than minimum documentation to the extent that such documents are included in the fields searched		
Electronic data base consulted during the international search (name of data base and, where practical, search terms used) EPO-Internal		
C. DOCUMENTS CONSIDERED TO BE RELEVANT		
Category*	Citation of document, with indication, where appropriate, of the relevant passages	Relevant to claim No.
X	WO 2006/034865 A (FRAMATOME CONNECTORS INT [FR]; CHAZOTTES FREDERIC [FR]; CASSES CLAUDE) 6 April 2006 (2006-04-06) cited in the application the whole document	1-10
A	EP 1 009 065 A (SUMITOMO WIRING SYSTEMS [JP]) 14 June 2000 (2000-06-14) paragraph [0048]; figure 1314	1
A	WO 2006/108610 A (FRAMATOME CONNECTORS INT [FR]; CHAZOTTES FREDERIC [FR]; CAMPFORT CHRIS) 19 October 2006 (2006-10-19) cited in the application abstract; figures 1-5	1
-/--		
<input checked="" type="checkbox"/> Further documents are listed in the continuation of Box C.		
<input checked="" type="checkbox"/> See patent family annex.		
* Special categories of cited documents :		
A document defining the general state of the art which is not considered to be of particular relevance *E* earlier document but published on or after the international filing date *L* document which may throw doubts on priority claim(s) or which is cited to establish the publication date of another citation or other special reason (as specified) *O* document referring to an oral disclosure, use, exhibition or other means *P* document published prior to the international filing date but later than the priority date claimed	*T* later document published after the international filing date or priority date and not in conflict with the application but cited to understand the principle or theory underlying the invention *X* document of particular relevance; the claimed invention cannot be considered novel or cannot be considered to involve an inventive step when the document is taken alone *Y* document of particular relevance; the claimed invention cannot be considered to involve an inventive step when the document is combined with one or more other such documents, such combination being obvious to a person skilled in the art. *&* document member of the same patent family	
Date of the actual completion of the international search <p style="text-align: center; font-weight: bold;">20 May 2009</p>	Date of mailing of the international search report <p style="text-align: center; font-weight: bold;">29/05/2009</p>	
Name and mailing address of the ISA/ European Patent Office, P.B. 5818 Patentlaan 2 NL - 2230 HV Rijswijk Tel. (+31-70) 340-2040, Fax: (+31-70) 340-3016	Authorized officer <p style="text-align: center; font-weight: bold;">Jiménez, Jesús</p>	

INTERNATIONAL SEARCH REPORT

International application No PCT/US2009/040356

C(Continuation). DOCUMENTS CONSIDERED TO BE RELEVANT		
Category*	Citation of document, with indication, where appropriate, of the relevant passages	Relevant to claim No.
A	US 4 973 268 A (SMITH ALBERT R [US] ET AL) 27 November 1990 (1990-11-27) cited in the application column 6, line 51 - column 7, line 25; figures 6-8	1
A	US 2004/132352 A1 (WARD BOBBY GENE [US] ET AL) 8 July 2004 (2004-07-08) abstract; figure 6	1

INTERNATIONAL SEARCH REPORT

Information on patent family members

International application No PCT/US2009/040356

Patent document cited in search report	A	Publication date	Patent family member(s)	Publication date
WO 2006034865	A	06-04-2006	CN 101032058	05-09-2007
			EP 1800372	27-06-2007
			FR 2875957	31-03-2006
			JP 2008515154	08-05-2008
			KR 20070051373	17-05-2007
			US 2008070441	20-03-2008
EP 1009065	A	14-06-2000	DE 69902863	17-10-2002
			DE 69902863	28-05-2003
			JP 3864592	10-01-2007
			JP 2000173709	23-06-2000
			US 6155888	05-12-2000
WO 2006108610	A	19-10-2006	CN 101208838	25-06-2008
			JP 2008536278	04-09-2008
			KR 20070122537	31-12-2007
			US 2009042434	12-02-2009
US 4973268	A	27-11-1990	NONE	
US 2004132352	A1	08-07-2004	NONE	