

(No Model.)

C. E. BILLINGS.
HAND VISE.

No. 525,311.

Patented Aug. 28, 1894.

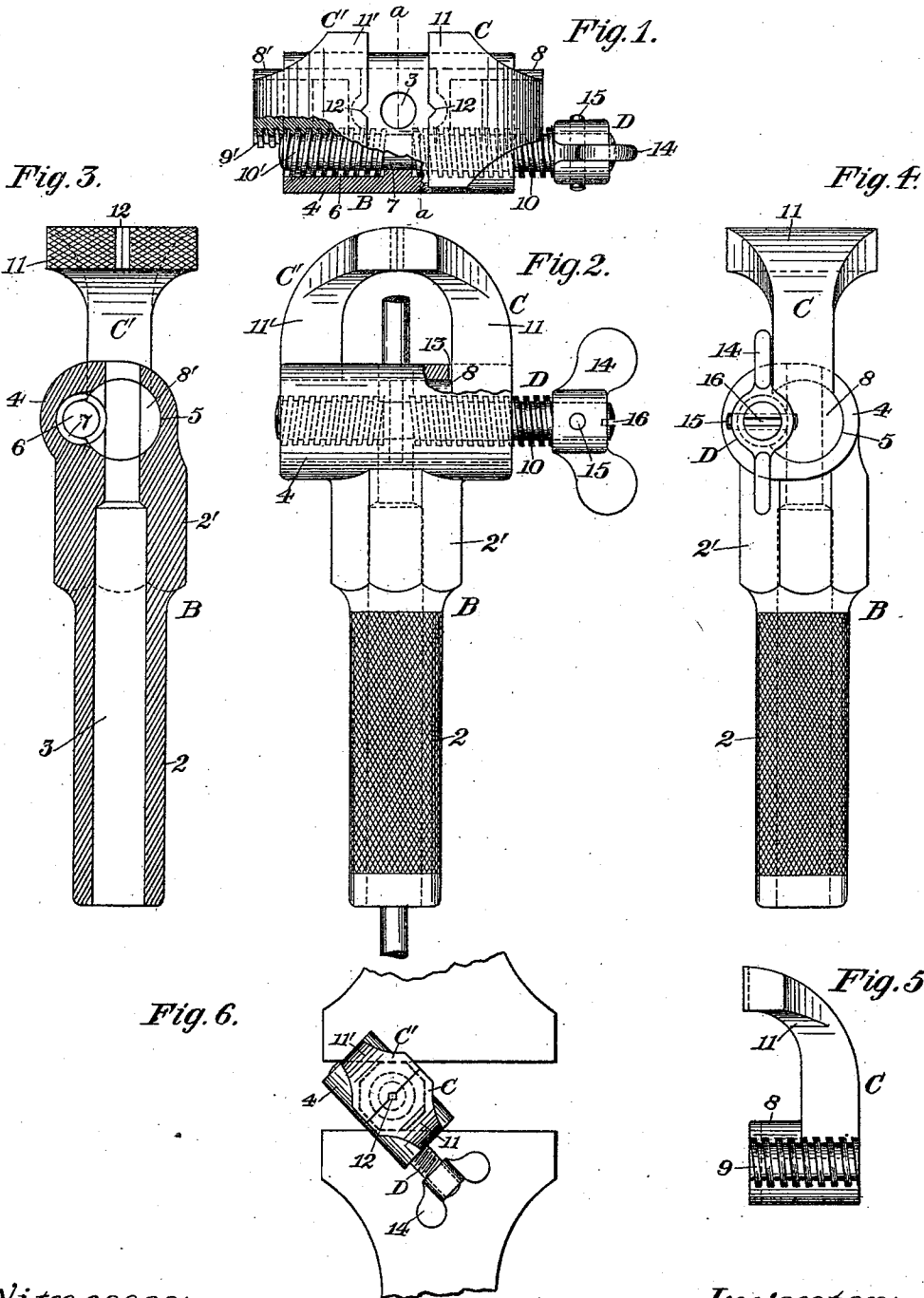

Witnesses:

S. L. Edwards Jr.
Fred. J. Dole.

Inventor:

Charles E. Billings.
By his Attorney,

F. W. Richards

UNITED STATES PATENT OFFICE.

CHARLES E. BILLINGS, OF HARTFORD, CONNECTICUT.

HAND-VISE.

SPECIFICATION forming part of Letters Patent No. 525,311, dated August 28, 1894.

Application filed April 6, 1894. Serial No. 506,571. (No model.)

To all whom it may concern:

Be it known that I, CHARLES E. BILLINGS, a citizen of the United States, residing at Hartford, in the county of Hartford and State of Connecticut, have invented certain new and useful Improvements in Hand-Vises, of which the following is a specification.

This invention relates to that class of vises known as "hand-vises;" the objects of the invention being to furnish a strong, durable and efficient hand-vise especially adapted for jewelers' and tool-makers' use for holding rods, small tools or tool-blanks, and analogous articles, and to so construct and organize the parts of the hand-vise that the work-grasping jaws will have a positive opening and closing movement in parallel lines, and whereby the parts may be readily assembled and disassembled, and also to provide means whereby the hand-vise may be firmly held between the jaws of a bench-vise at various angles with relation to a given line bisecting the work held by the jaws of said vise.

In the drawings accompanying and forming a part of this specification, Figure 1 is a plan view, partially in section, of a hand-vise constructed and organized in accordance with my invention, the jaws of the hand-vise being shown partially open. Fig. 2 is a side elevation, partially in section, of the hand-vise, the jaws thereof being shown as closed. Fig. 3 is a longitudinal section of the same, taken in line *a-a*, Fig. 1, looking toward the left-hand in said figure, the jaw-operating screw being removed. Fig. 4 is a front elevation of said hand-vise. Fig. 5 is a detail, in side elevation, of one of the work-grasping jaws. Fig. 6 is a plan view of the hand-vise, on a smaller scale, showing the manner of clamping the same at an angle between the jaws of a bench-vise, a portion only of the jaws of the bench-vise being shown.

Similar characters designate like parts in all the figures.

My invention, in the preferred form thereof herein shown and described, consists of a hand-vise comprising a longitudinally-recessed body, or handle-portion, having a head recessed in alignment with, but at right angles to, the recess of the body-portion, to

form a slide-way for the work-grasping jaws; two oppositely-disposed work-grasping jaws supported for parallel sliding movement in the slide-way of the head, and an adjusting-screw in engagement with said jaws at one side thereof and at one side of the recess in the handle or body-portion, as will be hereinafter more fully described.

In the preferred form thereof herein shown, the body-portion, B, of the vise consists of a handle, 2, which is centrally bored its entire length, as shown at 3, (see Fig. 3,) and a transversely-disposed head, 4, which is longitudinally bored, as shown at 5, in axial alignment with, but at right angles to, the bore 3 of the handle, which bore 5 forms a slide-way for the shanks 8 and 8' of the work-grasping jaws C and C'. Formed at one side of and in parallelism with the axis of the bore 5 of the head, is a substantially semi-circular bore, 6, open at one side thereof, as shown in Fig. 3, said bore being counter-bored from each end to form a screw-retaining shoulder, 7, at the middle portion thereof. This bore 6 constitutes a shouldered bearing for the jaw-operating screw D, the construction and operation of which will be more fully hereinafter explained.

The jaw-actuator D is herein shown as a screw of the right-and-left handed type, it having a right-handed thread, 10, at one end, and a left-handed thread, 10', at the opposite end, coinciding with and adapted for engaging with the similar threads 9 and 9' in the side-faces of the jaws C and C', a space being left between the adjacent ends of the threads 10 and 10' of the adjusting-screw D to receive the shoulder 7 which prevents longitudinal movement of the screw when the parts are assembled.

The work-grasping jaws are herein shown as comprising the cylindrical shank-portions 8 and 8', respectively, adapted for fitting the slide-way in the head 4 and screw-threaded at the outer sides thereof, as shown in Fig. 5, and the upwardly and inwardly projecting work-grasping arms 11 and 11' notched at their inner adjacent faces, as shown at 12, to form the "bite" to prevent lateral movement of the article held between the jaws.

The shanks 8 and 8' of the jaws C and C' (which shanks are in the nature of slides and are adapted to closely fit the slide-way 5 of the head 4), have substantially semi-circular screw-threaded bearings, 9 and 9', formed at one side thereof contiguous to the bearing 6 of the head 4, the diameters of the bearings 9 and 9' coinciding with the diameter of the bearing 6, as will be clearly apparent by reference to Fig. 3 of the drawings.

To permit the opening and closing movement of the work-grasping jaws, and still secure the greatest durability and rigidity to the head-portion 4 of the vise, said head is grooved or slotted transversely at the side adjacent to the work-grasping jaws a portion of its length from each end thereof, as shown at 13, most clearly in Fig. 2, leaving a bridge-wall or strengthening-wall at the central portion of the head between the guiding-grooves 13, said guiding-grooves being of sufficient length, however, to permit the complete closing of the jaws.

The adjusting-screw is provided at one end with a thumb-piece, 14, which is removably secured thereto by means of a pin, 15, as clearly shown in said Fig. 2.

To enable the hand-vise to be clamped between the jaws of a bench-vise at different angles, the handle 2 of said vise, adjacent to the head 4, is of octagonal cross-section, as shown at 2', which permits the vise to be placed between the jaws and clamped in four different positions, as will be understood by reference to Fig. 6 of the drawings.

In assembling the parts, assuming the thumb-piece 14 to be removed from the screw, and the jaws C and C' removed from the head 4, the adjusting-screw D is extended longitudinally into the bore 5 of the head, after which, by a lateral movement, it is seated in the bearing 6 at one side of said bore, with the shoulder 7 of the head bearing between the adjacent ends of the screw-threads 10 and 10' thereof; the work-grasping jaws are then placed in position with their slides or shanks 8 and 8' in position to enter the bore 5 and with their screw-threads in meshing engagement with the screw-threads of the adjusting-screw D, after which the adjusting-screw is turned by means of a screw-driver extended into a notch, 16, formed in one end thereof, until the shanks of the jaws are extended into the slide-way 5 of the head; the thumb-piece 14 is then secured to the end of the adjusting-screw D; this completes the operation of assembling the parts of the vise.

In Fig. 2 of the drawings, a piece of material is shown extended through the handle and head of the vise, to illustrate the manner of handling long pieces of work.

Having thus described my invention, I claim—

1. A hand-vise comprising a longitudinally and transversely bored body-portion, a pair

of oppositely-disposed jaws supported for sliding movement in the transverse bore of the body-portion, and an adjusting device for said jaws located at one side of and out of vertical alignment with the two said bores of the body-portion, substantially as described and for the purpose set forth.

2. A hand-vise comprising a longitudinally and transversely bored body-portion, two oppositely-disposed work-grasping jaws supported for sliding movement in the transverse bore of the body-portion, and a screw located at one side of, and engaging the side edges of said jaws out of vertical alignment with said bores of the body-portion, and adapted for simultaneously moving the two jaws toward or from each other in parallel lines, substantially as described and for the purpose set forth.

3. A hand-vise comprising a longitudinally-bored body-portion having a transversely-disposed head with a slide-way formed there-through in alignment with, but at right angles to, the longitudinal bore of the body-portion, two oppositely-disposed work-grasping jaws having shanks to fit the slide-way in the head of the body-portion, one of said jaws having a right-handed screw-thread formed in the periphery of its shank, and the other of said jaws having a left-handed screw-thread formed in the periphery of its shank, and a right-and-left handed screw in engagement with the right-and-left handed screw-threads of the jaws, and which screw is supported in a bearing located at one side of the slide-way and is adapted for simultaneously moving the two jaws toward or from each other, substantially as described and for the purpose set forth.

4. In a hand-vise, in combination, a body-portion comprising a longitudinally-bored handle having a transversely-disposed head with a slide-way therein in alignment with the bore of the handle but at right angles thereto, and having a substantially semi-circular screw-receiving bearing at one side of, and in alignment with the axis of the slide-way, two work-grasping jaws supported for sliding movement in the slide-way and each having a semi-circular screw-threaded groove at one side thereof, a screw seated in the bearing of the head at one side of the slide-way and having screw-threads in engagement with the screw-threads of the jaws and constructed to simultaneously move said jaws toward or from each other, and means for preventing longitudinal displacement of the screw, substantially as described and for the purpose set forth.

5. In a hand-vise, in combination, a longitudinally-bored body-portion, the head of which has a transverse slide-way and a shouldered semi-circular bearing formed at one side of said slide-way, a pair of work-grasping jaws supported for sliding movement in the slide-way and having, one a right-hand,

and the other a left-hand screw-thread formed
in the periphery thereof, a jaw-actuator con-
sisting of a right-and-left handed screw sup-
ported in a bearing in the head and engaging
5 the right-and-left handed screw-threads of the
jaws, and a thumb-piece in connection with
said actuator for turning the same to simul-

taneously move said jaws toward or from each
other, substantially as described and for the
purpose set forth.

CHARLES E. BILLINGS:

Witnesses:

CHARLES E. JOHNSON,
FRED. J. DOLE.