

(19)



Europäisches Patentamt

European Patent Office

Office européen des brevets



(11)

EP 0 555 935 B1

(12)

EUROPEAN PATENT SPECIFICATION

(45) Date of publication and mention
of the grant of the patent:

12.06.1996 Bulletin 1996/24

(51) Int. Cl.⁶: **A47F 3/06, A47F 5/00**

(21) Application number: **93200400.5**

(22) Date of filing: **12.02.1993**

(54) **Take-out basket rack**

Ausgabebehälterregal

Etagère de conteneur du distribution

(84) Designated Contracting States:
BE DE DK ES FR GB IT NL PT SE

(30) Priority: **14.02.1992 NL 9200278**

(43) Date of publication of application:
18.08.1993 Bulletin 1993/33

(73) Proprietor: **Sara Lee/DE N.V.**
NL-3532 AA Utrecht (NL)

(72) Inventor: **Jansen, Tino**
NL-5641 PE Eindhoven (NL)

(74) Representative: **Smulders, Theodorus A.H.J., Ir. et
al**

**Vereenigde Octroibureaux
Nieuwe Parklaan 97
2587 BN 's-Gravenhage (NL)**

(56) References cited:

**WO-A-88/10083
FR-A- 2 412 290
US-A- 5 026 129**

**DE-U- 8 515 351
US-A- 3 471 209**

EP 0 555 935 B1

Note: Within nine months from the publication of the mention of the grant of the European patent, any person may give notice to the European Patent Office of opposition to the European patent granted. Notice of opposition shall be filed in a written reasoned statement. It shall not be deemed to have been filed until the opposition fee has been paid. (Art. 99(1) European Patent Convention).

Description

The invention relates to a rack having take-out baskets or similar display/take-out containers for merchandise in a retail business, in particular a self-service shop.

Known display/take-out shelves for merchandise items such as nuts packed in bags or pouches, or fragile merchandise items packed under inclusion of air, such as crisps and the like, are often baskets made from bar grating material, either in shallow drawer form or in the form of a deep box having a filling opening at the top and an inclined bottom, with a take-out opening provided in the front wall at the bottom end facing the consumer. In accordance with the "first-in, first-out" principle, only those merchandise items are accessible to the consumer that were first placed into the basket, and the other merchandise items present in the basket are protected against undesired manipulation and damage.

Shallow drawer-shaped baskets are usually arranged one closely below the other and it is desired that they can be pulled out in turns so that they can be filled. In particular in the case of deep take-out baskets, arranged at a higher level, the take-out portion is still within the consumer's reach, however, it is desired that the basket can temporarily be moved to a lower level so that it can be filled. To enable displacement between a higher position against the rear wall and between the mounting columns of a rack, and a lower filling position in front of the rack, known take-out baskets are suspended from a tilting lever system via which a basket can be moved in upright position between the high level and the low level.

German Gebrauchsmuster 8515351 discloses a rack comprising shallow display/take-out containers having inclined bottoms, which, via a rail construction, are slidably extendible and retractable on opposite sides in inclined supports extending from rack columns, wherein stopping means are present for limiting the lower, extended position, while the upper, retracted position can be fixed by a lock operable from the front of the container, and wherein tension springs are provided between the front side of the container and the rack.

A drawback of this known apparatus is that the tension springs and the lock are arranged under the flat bottom in the central portion of the basket, which may impede the shifting of the merchandise over the bottom of a subjacent container.

The object of the invention is to provide a rack having display/take-out containers of the type described, having a displacement construction which is simple and takes up little space, not requiring any complicated tilting lever systems which take up much space, and wherein the above-mentioned drawback of the construction disclosed in the Gebrauchsmuster is avoided.

To this end, a rack having take-out baskets or similar display/take-out containers for merchandise in a retail business, in particular a self-service shop, wherein at least one basket is constructed as a drawer- or box-shaped container having an inclined bottom, the mer-

chandise items present in the basket are accessible to the consumer at the end of the bottom facing the consumer and the basket can be displaced along rails arranged at the side portions of the basket, between an upper position located against the rear wall and between mounting columns of the rack, and a bottom filling position located in front of the rack and limited by stopping means, is characterized according to the invention in that on each side of the basket, in a space below an inclined wall forming a transition between the bottom and a side wall, an assembly of the rails and a rod rotatably journaled parallel to the rails is connected to the basket, the stopping means are arranged at the rod and at the rails, and the stopping means of the rod, by rotation of the rod, can be caused to cooperate with the stopping means of the rails for defining at any rate the upper and lower positions, respectively, of the basket.

Particularly in the case of flat, shallow baskets, mounted at relatively low levels at a slight inclination directly above each other, accommodating the rails and the lock construction designed as a rotary rod in spaces formed below the side portions of the bottom has the advantage that the basket bottoms do not have any projecting parts at the underside, which impede the shifting of the merchandise items in a subjacent basket or render it difficult for a filled basket to be retracted.

In the case of deep baskets, which are usually arranged at a high level so as to utilize the space at the top of a rack for storing merchandise, and which must therefore be lowered at a relatively steep incline to be filled without necessitating the use of steps and the like, the vertical forces are considerable, also because of the great weight of the basket contents, so that lifting and lowering the basket requires much strength.

In this connection, the assemblies of the rails and rods can be supplemented with a tension spring, which, according to the invention, is likewise arranged in the space below a wall forming a transition between the bottom and a side wall.

To further explain the invention, a practical example of the take-out basket rack will now be described, by way of example only, with reference to the drawings.

Figure 1 is a detail side view of the guide system of a take-out basket;

Figure 2 is a top plan view of the detail of Figure 1 taken on line II-II in Figure 1;

Figure 3 is an end view of the detail of Figure 1 taken on line III-III in Figure 1;

Figure 4 is a schematic detail side view of an alternative manner of mounting the basket with the guide system on a rack column;

Figure 5 is a front view of the telescopic supporting beam which is part of the mounting system according to Figure 4; and

Figure 6 is a perspective view of a push construction for pushing rows of packed merchandise items towards the take-out end.

According to the drawings, a basket produced from bar grating material is mounted on columns of a display rack by means of a guide assembly 4 which is parallel to the inclined basket bottom 3. In the embodiment shown, the guide assembly is accommodated in spaces 5

located below inclined walls 6 which form a transition between the bottom 3 and upright side walls 7 of the basket. The guide assembly 4 comprises rails 8, known per se, of which a stationary portion 9 is connected to the rack 2 and a movable part 10 is connected to the basket 1 via a section 11. Mounted on section 11 are laterally projecting supports 12, wherein a rod 14 is journalled so as to be rotatable about its axis. Rod 14 carries stopping means in the form of lugs 15.

A section 16, connected to the stationary portion 9 of the rails or directly to the rack 2, comprises stopping means in the form of bent-out lugs 17, the rotation of rod 14, which comprises an end hook 14a for gripping, allowing stopping lugs 15 of the rod to be swung between a downward position as shown in Figures 1 and 2, wherein stopping lugs 17 of section 16 prevent rod 14 from moving and thereby prevent basket 1 from moving downwards, and a horizontal position, in which rod 14 and consequently also the basket are capable of moving downwards. This downward movement is limited by lug 15 at the rear end of rod 14 abutting against lug 17 at the front end of section 16.

In the embodiment of the guide means 4 as shown, a tube 18 is mounted on support 12 at the end of guide means 4 by a screw 19. Accommodated in tube 18 is a helical spring 20 having its rear end mounted on the column 2 at 21.

In Figures 1 and 2 it can be seen that basket 1 is provided with an awning-shaped top front wall 22. Between this wall 22 and a low bottom front wall 23, the products offered for sale, schematically indicated in the drawing as bags 24 with food, are within the consumer's reach. The awning-shaped top front wall is dimensioned such that a stock of bags 24 is stored at the top of basket 1 and bags 24 slide on automatically as a single layer over basket bottom 3 upon removal of the foremost bags lying on the bottom.

Now follows a description of the displacement of basket 1 from a high position, in which the rear wall of the basket is located between columns of the rack 2, to a low position, in which the basket is located in front of the rack and is more readily accessible for filling and the like.

For enabling a downward movement, rod 14 is gripped at the end hook 14a and rotated over 90° such that downwardly extending stopping lugs 15 are swung laterally and move beyond the reach of stopping lugs 17 which are stationarily connected to the fixed portion of the rack. Now, the basket can be lowered while being guided, a part of the weight of the basket and the contents thereof being taken up by spring 20. When rod 14 is rotated reversely, the abutment of rear lug 15 against lug 17 prevents further downward movement and via

these lugs the weight of the basket is taken up in the stationary portion of the apparatus.

When the basket is to be shifted upwards again, the rod is rotated again and the basket is pushed upwards, spring 22 contributing to the upward movement. The high position is locked by rotating the rod back to the position shown in the drawing.

Figures 4 and 5 show an alternative manner of mounting a take-out basket, which may be of the type discussed with reference to Figures 1-3, on a display rack having parallel columns 2.

The problem with such display racks is that the columns often do not have the exact interspace intended, i.e., the space between two successive columns may vary slightly.

In the manner of suspending take-out baskets as shown in Figure 1, where the stationary portion 9 of the extendible rail assemblies 8, 9 is always connected to a rack column, such deviations from the intended interspaces of the rack columns may cause problems.

According to Figure 4, a supporting beam 25, extending along the bottom edge of the rear wall of the basket, is used for the connection between a rack column and the stationary rail portion 9 or any other portion that is also connected to a take-out basket.

Supporting beam 25 comprises two telescopic tube sections 26, 27, of rectangular design in the embodiment shown, at the free ends thereof provided with hooks 28, through which the supporting beam and the take-out basket mounted thereon can be suspended from two rack columns 2. Because the two supporting beam portions 26, 27 are telescopic, being for instance extensible by about 3 centimetres, small deviations from the intended distance between two successive rack columns can be compensated.

In Figure 6, a push element 29 is shown that can be used advantageously in a take-out basket of the type set forth in the present application, particularly so when the basket has a bottom of grating bars inclined towards the take-out end.

For pushing the rows of packed merchandise items, for instance bags of peanuts, towards the front side or take-out side, it is known to pre-load such push elements towards the take-out end of the basket. In strongly inclined baskets, this pre-load can be realized by gravity or by using a push or pull spring of the helical spring type.

Such helical springs, of which at least one should be present in each push element, take up space in the bottom zone of a basket. Further, a helical spring, in released condition, has a considerable length in relation to the effective spring travel. Consequently, if a push element is to be loaded throughout its path along the bottom, the helical spring must not be arranged in front of or behind the push element in its bottom path, but beside or below the push element. In that case, the spring force must be transmitted to the push element via a wire or the like and a bend pulley.

In the embodiment according to Figure 6, the push element 29 is pre-loaded by a spring in the form of a self-

coiling helical spring 31. In the released, coiled condition, this spring takes up very little space and can be mounted directly between the push element 29 and a fixed point at the basket bottom 3 so as to be operative in the bottom surface.

In the embodiment shown, helical spring 31 is accommodated in push element 29 and fixed at the front edge of the basket bottom at a beam 32.

Both in the coiled condition and in the extended condition, helical spring 31 hardly takes up any space and hence does not form any obstacle to packages 24 present in a basket or in a subjacent basket.

In the take-out basket rack according to the invention, end hooks 14a of rods 14 at the take-out side of baskets 1 can be covered by caps 33, indicated in Figure 1. Thus, the basket is prevented from being unlocked accidentally and sliding downwards.

Claims

1. A rack having take-out baskets or similar display/take-out containers for merchandise in a retail business, in particular a self-service shop, in which at least one basket (1) is constructed as a drawer- or box-shaped container having an inclined bottom (3), the merchandise items (24) present in the basket (1) are accessible to the consumer at the end of the bottom facing the consumer and the basket (1) can be displaced along rails (8, 9) arranged at the side portions of the basket (1), between an upper position in which the rear wall of the basket (1) is located between mounting columns of a rack (2), and a bottom filling position in which the basket (1) is located in front of the rack (2) and limited by stopping means (15, 17), characterized in that on each side of the basket (1), in a space (5) below an inclined wall (6) forming a transition between the bottom (3) and a side wall (7), an assembly of the rails (8, 9) and a rod (14) rotatably journaled parallel to the rails construction is connected to the basket (1), the stopping means (15, 17) are arranged at the rod (14) and at the rails (8, 9), and the stopping means (15) of the rod (14), by rotation of the rod (14), can be caused to cooperate with the stopping means (17) of the rails (8, 9) for defining the upper and lower positions, respectively, of the basket (1).
2. A rack according to claim 1, in which tension springs (20) are connected, at one end, to the basket (1) and, at the other, to the rack columns (2), characterized in that for each assembly of rails (8, 9) and a rod (14), a tension spring (20) is arranged in said space (5).
3. A rack according to claim 1 or 2, characterized in that for the connection between a rack column (2) and the stationary rail portion (9) or any other portion also connected to a take-out basket, use is made of a supporting beam (25), extending along the bottom

edge of the rear wall of the basket (1) and comprising two telescopic tube sections (26, 27), said supporting beam (25) being provided, at the free ends thereof, with hooks (28) permitting the supporting beam (25) and the take-out basket (1) mounted thereon to be suspended from two rack columns (2).

4. A rack according to any one of the preceding claims, in which push elements (29) are capable of being slid over the basket bottom (3) over the bottom bars (30) and spring means (31) are present for pushing rows of packed merchandise items (24) toward the take-out side of the basket (1), characterized in that the spring means are formed by a self-coiling helical spring (31), mounted directly between the push element (29) and a fixed point (32) at the front edge of the basket bottom (3) so as to be operative in the bottom surface (3).
5. A rack according to any one of the preceding claims, characterized in that the end hook (14a) of the rod (14) being part of the basket lock, is covered by a cap (33).

Patentansprüche

1. Regal mit Ausgabebehältern oder ähnlichen Schau/Ausgabefächern für Waren in einem Ladengeschäft, insbesondere einem Selbstbedienungsgeschäft, wobei mindestens ein Behälter (1) als schubladen- oder kastenförmiges Fach mit einem geneigten Boden (3) ausgebildet ist, wobei in dem Behälter (1) vorhandene Artikel (24) für den Verbraucher an dem dem Verbraucher zugewandten Ende des Bodens zugänglich sind und der Behälter (1) über an den Seitenteilen des Behälters (1) angeordnete Schienen (8, 9) zwischen einer oberen Stellung, in der die Rückwand des Behälters (1) sich zwischen Montageholmen eines Regals (2) befindet, und einer unteren Füllstellung, in der der Behälter (1) sich vor dem Regal (2) befindet und die durch Anschlagmittel (15, 17) begrenzt ist, verschiebbar ist, dadurch gekennzeichnet, daß an jeder Seite des Behälters (1) in einem Raum (5) unter einer einen Übergang zwischen dem Boden (3) und einer Seitenwand (7) bildenden geneigten Wand (6) eine Kombination der Schienen (8, 9) und einer parallel zu der Schienenkonstruktion drehbar gelagerten Stange (14) mit dem Behälter (1) verbunden ist, wobei die Anschlagmittel (15, 17) bei der Stange (14) und den Schienen (8, 9) angeordnet sind und die Anschlagmittel (15) der Stange (14) durch Drehung der Stange (14) zur Zusammenarbeit mit den Anschlagmitteln (17) der Schienen (8, 9) gebracht werden können, um wenigstens die obere bzw. untere Stellung des Behälters (1) zu bestimmen.
2. Regal nach Anspruch 1, wobei Zugfedern (20) einerseits mit dem Behälter (1) und andererseits mit den

Regalholmen (2) verbunden sind, dadurch gekennzeichnet, daß für jede Kombination von Schienen (8, 9) und einer Stange (14) eine Zugfeder (20) in dem genannten Raum (5) angeordnet ist.

3. Regal nach Anspruch 1 oder 2, dadurch gekennzeichnet, daß für die Verbindung zwischen einem Regalholm (2) und dem ortsfesten Schienenteil (9) oder einem anderen Teil, der auch mit einem Ausgabehälter verbunden ist, ein Tragbalken (25) verwendet ist, der sich an dem unteren Rand der Rückwand des Behälters (1) entlang erstreckt und zwei teleskopische Rohrprofile (26, 27) aufweist, welcher Tragbalken (25) an seinen freien Enden mit Haken (28) versehen ist, um den Tragbalken (25) und den daran befestigten Ausgabehälter (1) an zwei Regalholmen (2) aufhängen zu können.
4. Regal nach einem der vorhergehenden Ansprüche, wobei über den Behälterboden (3) Schubelemente (29) über die Bodenstäbe (30) verschiebbar sind und Federmittel (31) vorgesehen sind, um Reihen verpackter Waren (24) in Richtung auf die Ausgabeseite des Behälters (1) zu schieben, dadurch gekennzeichnet, daß die Federmittel durch eine sich selbst aufwickelnde Spiralfeder (31) gebildet sind, die in der Bodenfläche (3) wirksam unmittelbar zwischen dem Schubelement (29) und einem festen Punkt (32) bei dem vorderen Rand des Behälterbodens (3) angeordnet ist.
5. Regal nach einem der vorhergehenden Ansprüche, dadurch gekennzeichnet, daß der Endhaken (14a) der Stange (14), der Teil der Behälterverriegelung ist, durch eine Kappe (33) abgeschirmt ist.

Revendications

1. Etagère munie de paniers à extraire ou de récipients à extraire/présentoirs similaires pour des marchandises dans un magasin de détail, en particulier un self-service, dans laquelle au moins un panier (1) est construit comme un récipient en forme de tiroir ou de boîte possédant un fond incliné (3), les marchandises (24) présentes dans le panier (1) étant accessibles au consommateur à l'extrémité du fond tournée vers le consommateur et le panier (1) pouvant être déplacé le long de rails (8, 9) disposés sur les parties latérales du panier (1) entre une position supérieure dans laquelle la paroi postérieure du panier est située entre les colonnes de montage d'une étagère (2) et une position de remplissage du fond dans laquelle le panier (1) est situé à l'avant de l'étagère (2) et arrêté par des moyens de butée (15, 17), caractérisée en ce que, de chaque côté du panier (1), dans un espace (5) sous une paroi inclinée (6) formant une transition entre le fond (3) et une paroi latérale (7), un ensemble formé des rails (8, 9) et d'une tige (14), montée sur tourillon à rotation en parallèle à la construction de rails, est raccordé au panier (1), les moyens de butée (15, 17) étant disposés sur la tige (14) et sur les rails (8, 9) et les moyens de butée (15) de la tige (14), par rotation de la tige (14), pouvant être amenés à coopérer avec les moyens de butée (17) des rails (8, 9) pour définir les positions supérieure et inférieure respectives du panier (1).
2. Etagère selon la revendication 1 dans laquelle des ressorts de rappel (20) sont raccordés, à une extrémité, au panier (1) et, à l'autre extrémité, à la colonne de l'étagère (2), caractérisée en ce que, pour chacun des ensembles des rails (8, 9) et d'une tige (14), un ressort de rappel (20) est disposé dans ledit espace (5).
3. Etagère selon l'une des revendications 1 ou 2, caractérisée en ce que, pour la fixation entre une colonne d'étagère (2) et la partie fixe du rail (9) ou toute autre partie également raccordée au panier à extraire, est utilisé un profilé de support (25) s'étendant le long du bord du fond de la paroi postérieure du panier (1) et comprenant deux sections en tubes télescopiques (26, 27), ledit faisceau de support (25) étant doté à ses extrémités de crochets (28) permettant au profilé de support (25) et au panier à extraire (1) qui est fixé sur celui-ci d'être suspendus à deux colonnes de l'étagère (2).
4. Etagère selon l'une quelconque des revendications précédentes, dans laquelle des éléments poussoirs (29) sont capables de coulisser sur le fond du panier (3) au-dessus des barres de fond (30) et des moyens à ressort (31) sont présents pour pousser des rangées de marchandises emballées (24) vers le côté d'extraction du panier (1), caractérisée en ce que les moyens à ressort sont formés par un ressort hélicoïdal à boudin (31), monté directement entre l'élément poussoir (29) et un point fixe (32) sur le bord frontal du fond du panier (3) de manière à être opérationnel sur la surface du fond (3).
5. Etagère selon l'une quelconque des revendications précédentes, caractérisée en ce que le crochet d'extrémité (14a) de la tige (14) faisant partie du dispositif de verrouillage du panier est recouvert par un cache (33).

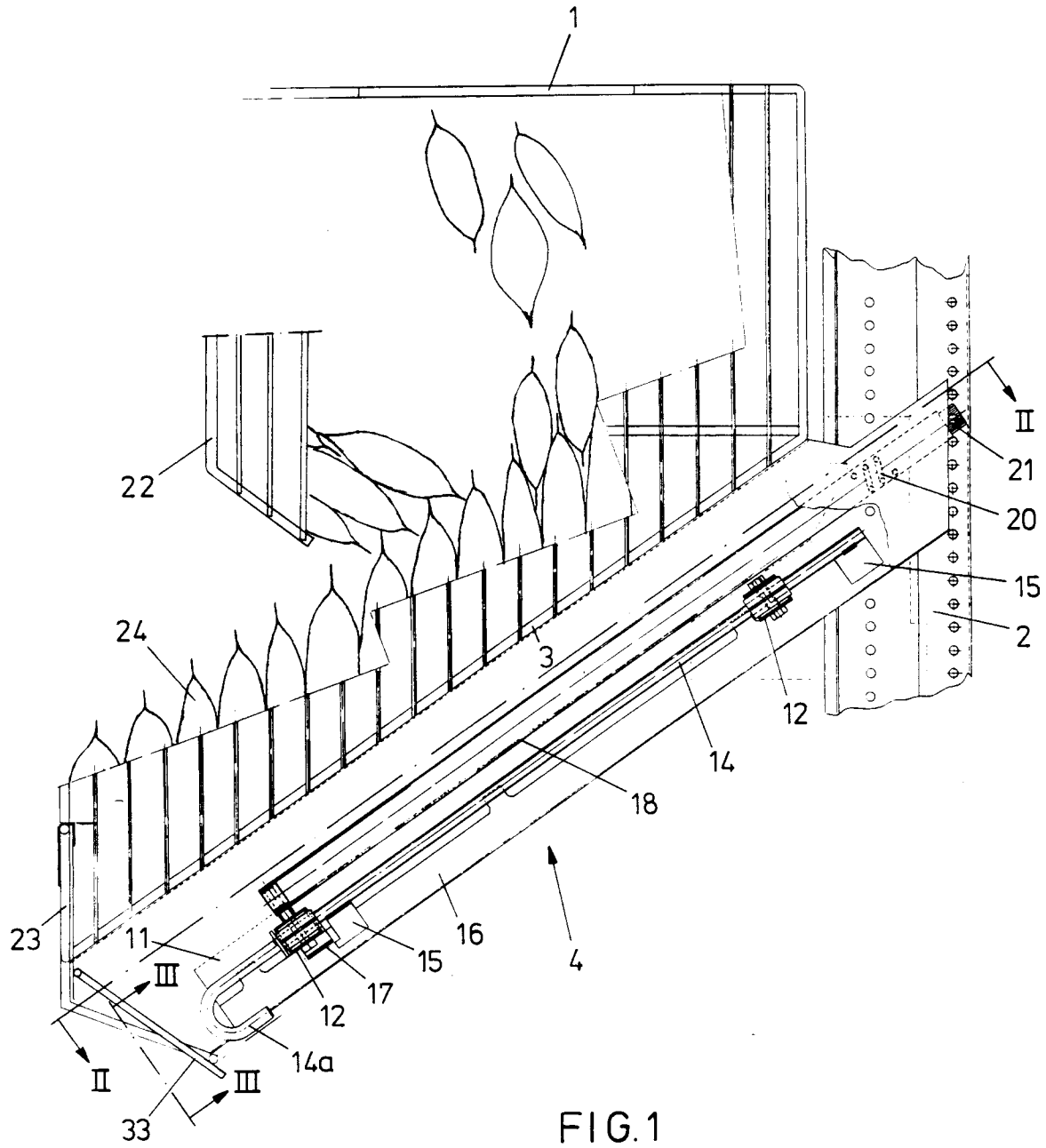

FIG.1

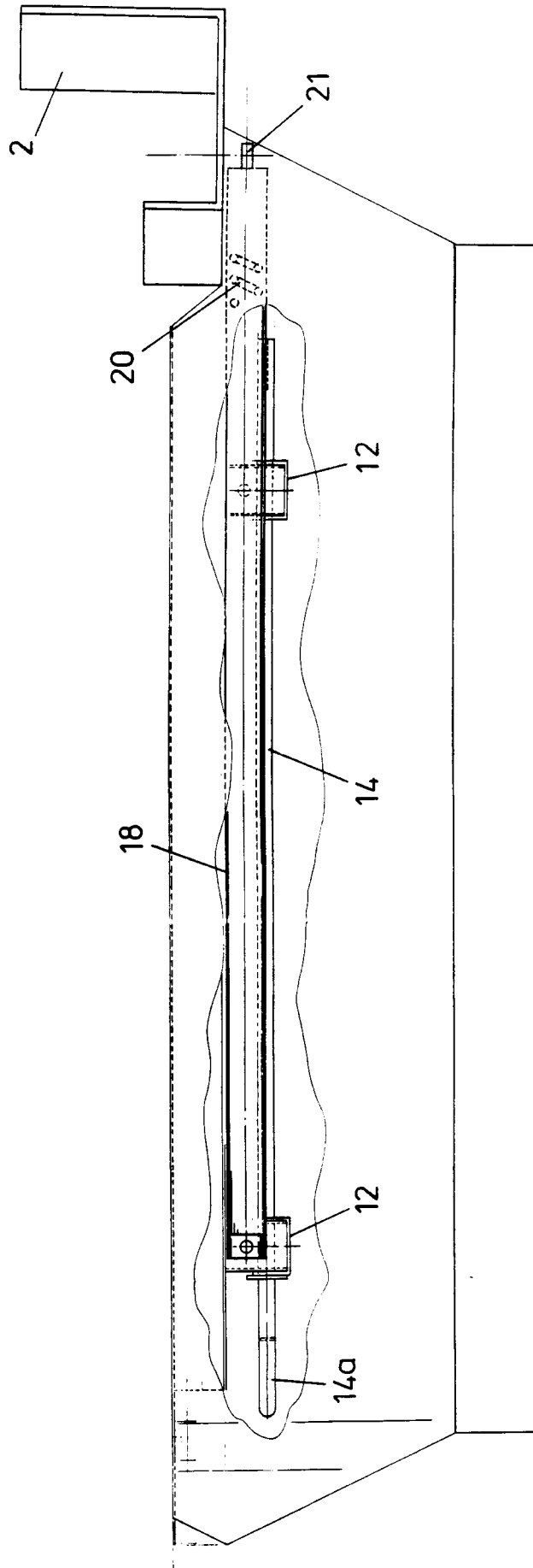

FIG. 2

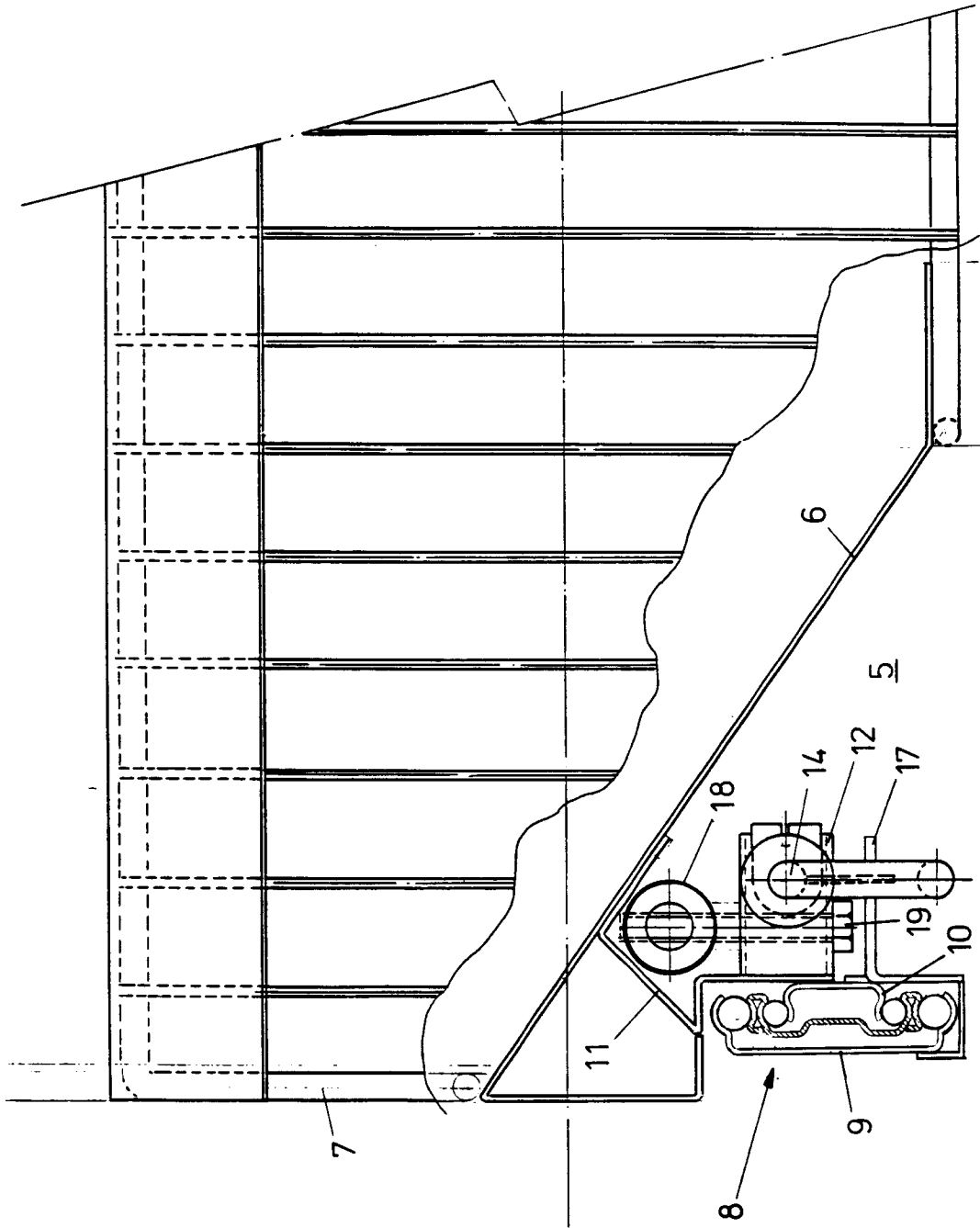

FIG. 3

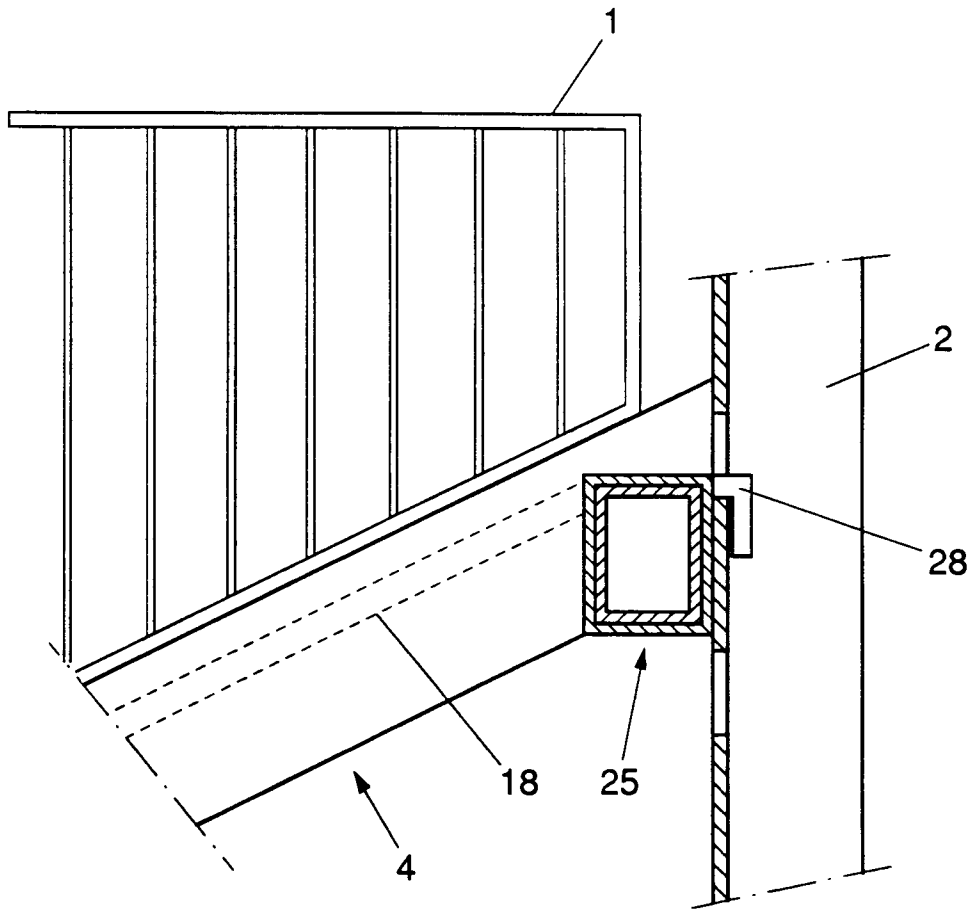

FIG. 4

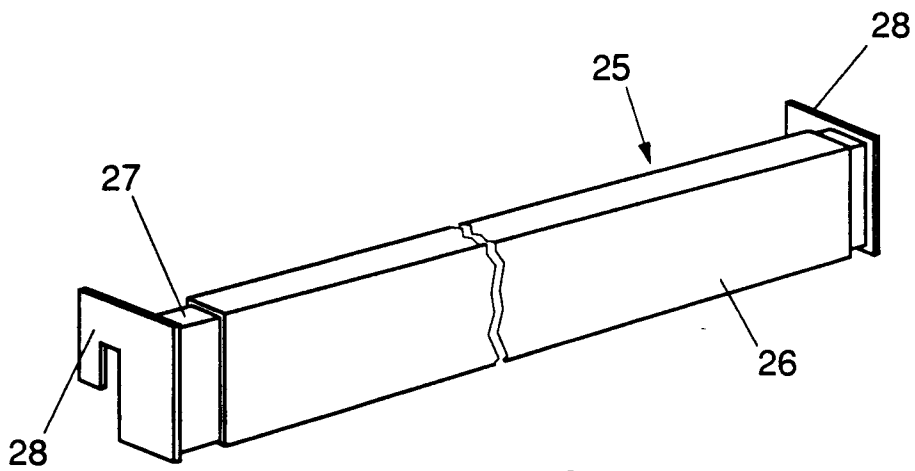

FIG. 5

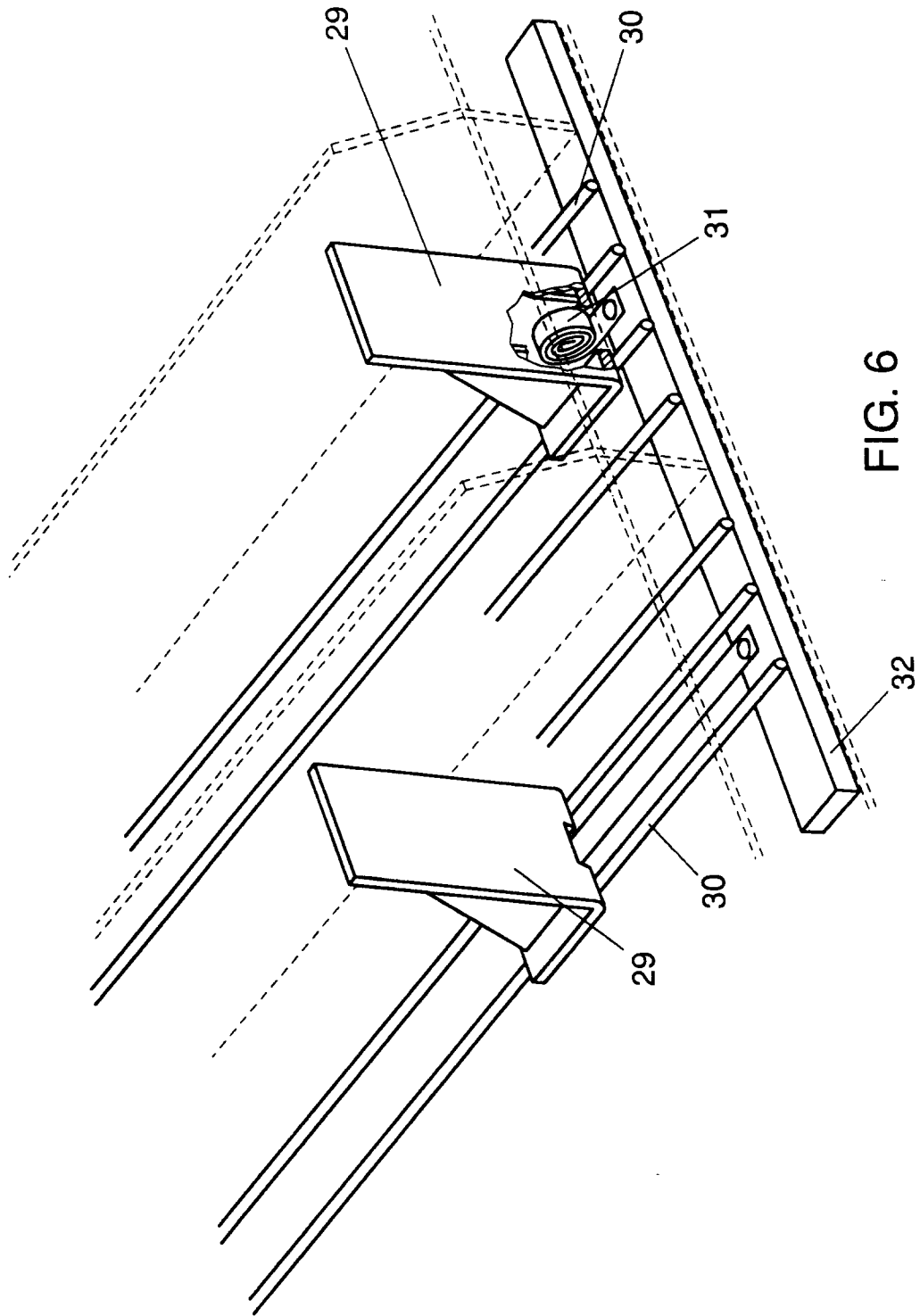

FIG. 6