

Sept. 19, 1961

S. EISEN
WEAVING MACHINE

3,000,403

Filed Jan. 13, 1960

3 Sheets-Sheet 1

Fig. 1

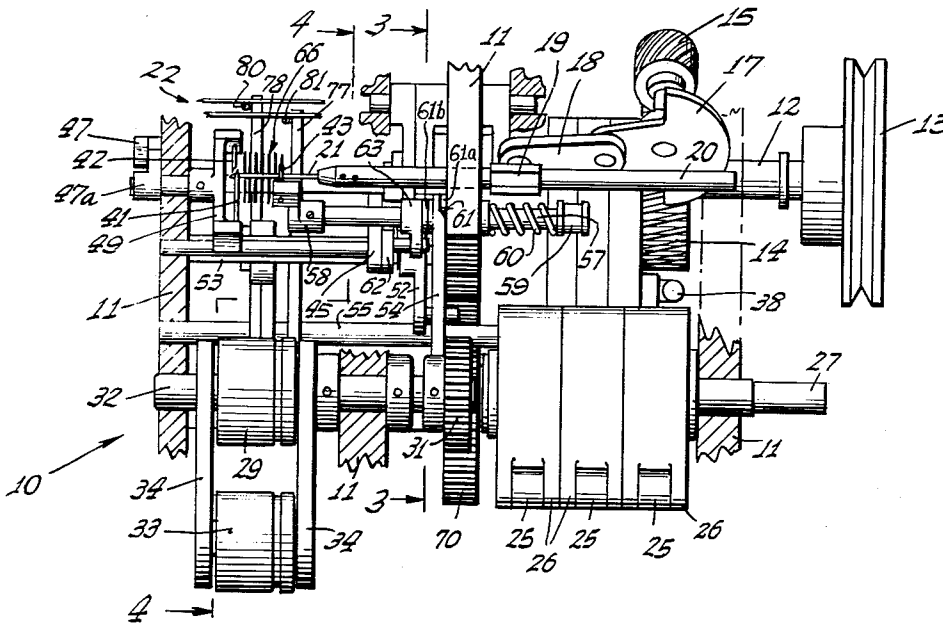
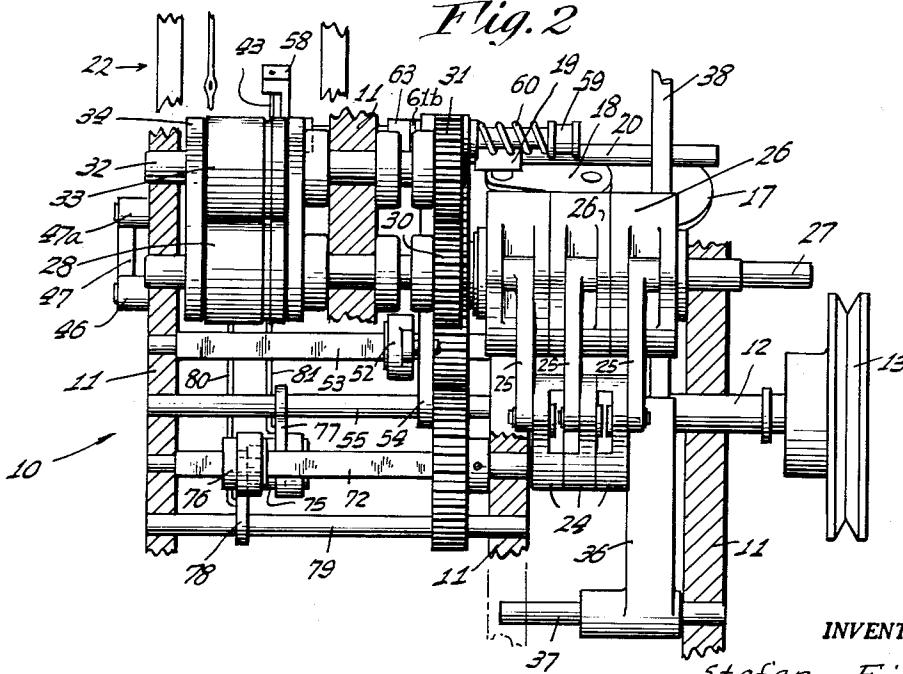

Fig. 2



INVENTOR.

BY Stefan Eisen

Johnson and Kline
ATTORNEYS

Sept. 19, 1961

S. EISEN
WEAVING MACHINE

3,000,403

Filed Jan. 13, 1960

3 Sheets-Sheet 2

Fig. 3

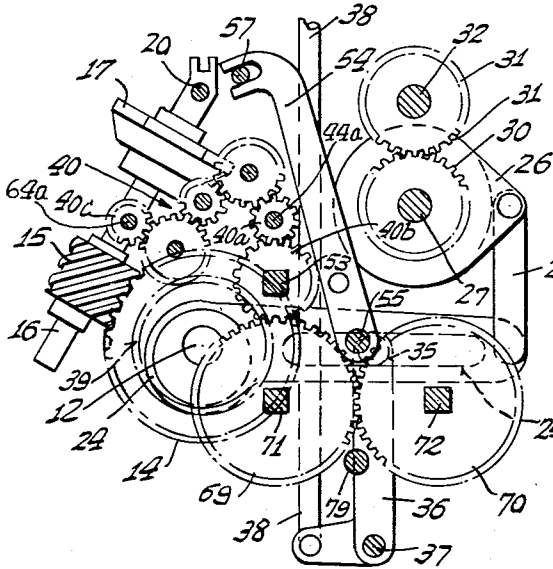

Fig. 5

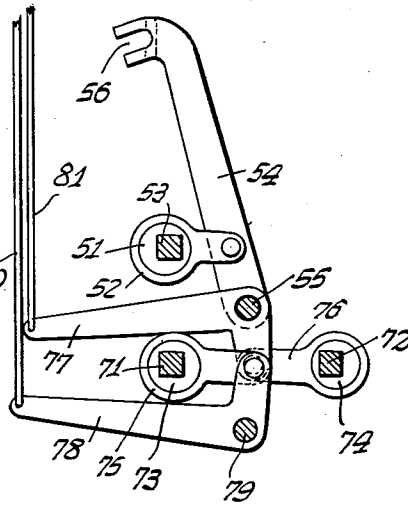

Fig. 4

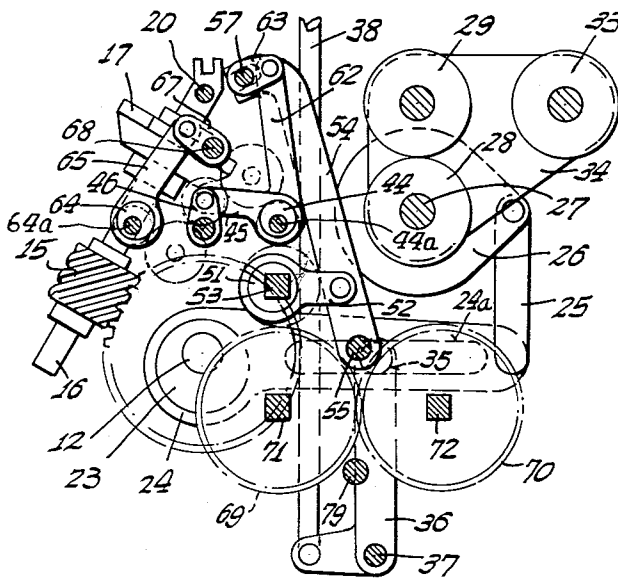

Fig. 6

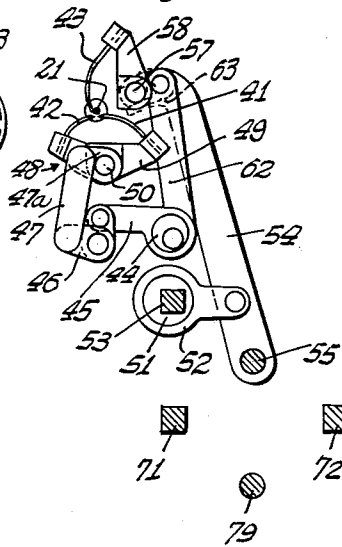
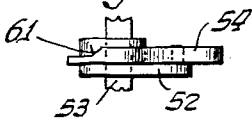

Fig. 7



INVENTOR.
Stefan Eisen
BY
Johnson and Kline
ATTORNEYS

Sept. 19, 1961

S. EISEN

3,000,403

WEAVING MACHINE

Filed Jan. 13, 1960

3 Sheets-Sheet 3

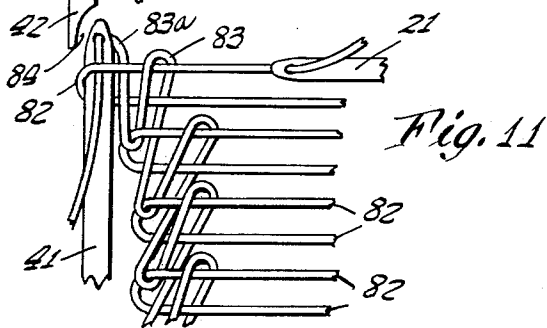
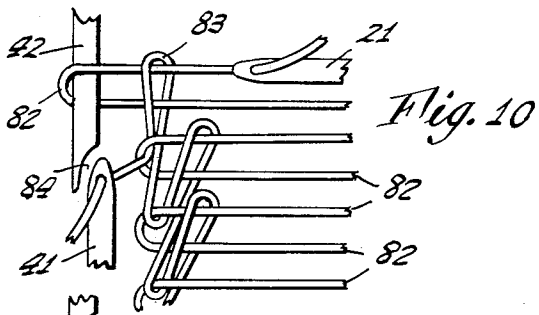
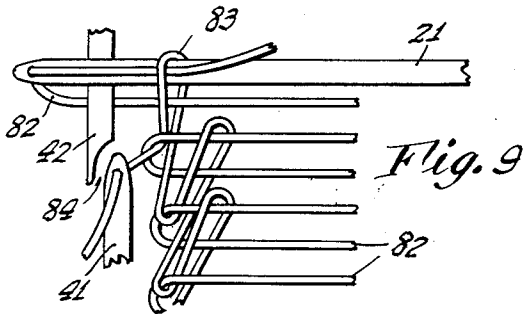
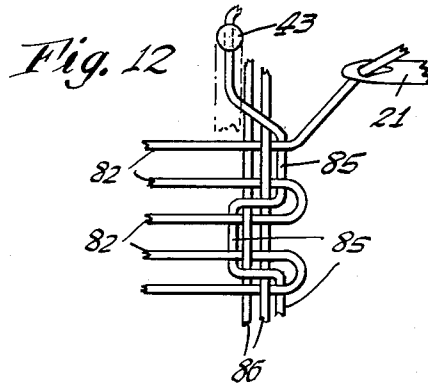
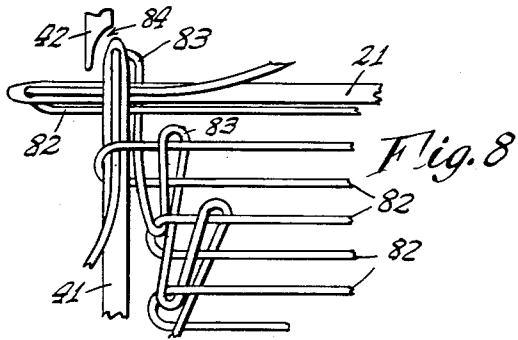

INVENTOR.
Stefan Eisen
BY
Johnson and Kline
ATTORNEYS

1

3,000,403

WEAVING MACHINE

Stefan Eisen, St. Hyacinthe, Quebec, Canada, assignor to Bridgeport Fabrics, Inc., Bridgeport, Conn., a corporation of Connecticut

Filed Jan. 13, 1960, Ser. No. 2,141

17 Claims. (Cl. 139-124)

This invention relates to looms for weaving narrow fabrics or the like. More specifically, it pertains to the loom mechanism for weaving the far and near selvages of the fabric.

An object of the invention is to provide in a loom, of the type wherein a weft thread in the form of a filling thread loop is inserted through the warps by a single needle being projected and withdrawn through the shed, a mechanism for weaving the far and near selvages so that the resulting fabric will not run, ravel or otherwise come apart when it is cut.

According to the invention, this object is achieved, with respect to the far selvedge, by providing means for passing a loop of locking thread through a loop of the filling thread and thereafter over the next following loop of filling thread.

The weaving of the near selvedge is achieved, according to the invention, by providing means for forming parallel laterally spaced loops of crossover thread along the near side of the shed, as the loops of filling thread are deposited therein, for receiving individual loops of the filling thread, the crossover loops being adapted to be wrapped around their respective filling thread loops as their insertion in the shed is completed.

It is another object of the invention to provide a mechanism for weaving a far selvedge which includes a curved needle adjacent the far side of the shed adapted to place a loop of locking thread over the weft carrying needle and a looper for picking up the loop of the weft or filling thread and depositing it on the curved needle so that a loop of locking thread is pushed therethrough to be extended over the next following loop of filling thread.

Yet, another object of the invention is to provide a mechanism for weaving the far selvedge wherein the curved locking thread needle and the looper are operated in predetermined timed relationship with respect to the filling thread needle.

It is also an object of the invention to provide a mechanism for weaving the near selvedge which includes a needle cooperating with a filling thread carrying needle for forming a loop of crossover thread in the shed through which the filling thread is passed as it is deposited in the shed, the crossover needle being adapted to wrap the loop of crossover thread around the loop of filling thread after it is completely deposited in the shed and thereafter being laterally shifted to form another loop of crossover thread in spaced parallel relation to the first loop thereof for receiving the next following loop of filling thread to be inserted in the shed.

It is also an object of the invention to provide a mechanism for weaving the near selvedge wherein the crossover needle is operated in predetermined timed relationship to the operation of the weft carrying needle.

It is further an object of the invention to provide a loom having a mechanism for weaving the far and near selvages of a fabric wherein the cooperating needle elements are all operated from a main drive shaft in predetermined timed relationship.

Other objects and advantages of the invention will be apparent from the specification and claims when considered in connection with the attached sheets of drawings illustrating one form of the invention, wherein like characters represent like parts and in which:

2

FIGURE 1 is a plan view of a loom embodying the present invention;

FIG. 2 is a front elevational view of the loom of FIG. 1;

FIG. 3 is a cross-sectional view taken in the direction of the arrows 3-3 in FIG. 1;

FIG. 4 is a cross-sectional view taken in the direction of the arrows 4-4 in FIG. 1;

FIG. 5 is a fragmentary view of the harness operating mechanism of the loom of FIG. 1 and a partial view of the mechanism for operating the crossover needle;

FIG. 6 is a fragmentary view of the mechanism for weaving the far and near selvages of a fabric as embodied in the loom of FIG. 1;

FIG. 7 is a fragmentary view of a portion of the mechanism for laterally shifting the crossover needle;

FIGS. 8 through 11 are diagrammatic illustrations showing the consecutive steps in the weaving of the far selvedge as achieved by the loom of FIGS. 1 through 7; and

FIG. 12 is a diagrammatic illustration showing steps of weaving the near selvedge as achieved by the loom of FIGS. 1 through 7.

Referring now to the drawings, and FIGS. 1 through 7 in particular, a loom 10 for weaving narrow fabrics or the like is shown having a frame 11 and a main drive shaft 12, rotatably supported thereby. The main drive shaft 12, which may be driven from any source of power (not shown) through a belt (also not shown) and a pulley 13 carried by the drive shaft, drives a helical gear 14 which engages a worm gear 15 to rotate a shaft 16 carrying a fly wheel 17. The fly wheel 17 is connected through a link 18 to a slide 19 carried by a reciprocable rod 20 having a straight needle 21 connected thereto. The straight needle 21, which is adapted to carry a filling thread or weft yarn rapidly back and forth through a shed formed by shed forming means 22 of conventional type that are operated in timed relation to the operation of the loom, as hereinafter described, is reciprocated with the rod 20 by the main drive shaft acting through the helical gear 14, worm gear 15, shaft 16, fly wheel 17 and link 18.

The drive shaft 12 mounts three eccentrics 23 having individual housings 24 which are adapted, on rotation of the main drive shaft and the eccentrics 23, to transmit a rocking motion through links 25 to a plurality of friction clutches 26 of any type known to the art. The friction clutches 26, which are here shown as three in number, are of such a character that they rotate the shaft 27 and material transport rolls 28 and 29 in one direction at a constant pitch, thereby defining and controlling the number of picks per inch of the woven fabric. As shown most clearly in FIGS. 3 and 4, the shaft 27 carries a gear 30, that engages a gear 31 carried by a shaft 32 which mounts the roll 29, for rotating the shaft 32 in the opposite direction from shaft 27, thus, causing rolls 28 and 29 to rotate in opposite directions and produce a pinch feed. A material guide roll 33 is rotatably mounted on the take-up roll frame 34 as is conventional in the art.

According to the invention, the movement of the transport rolls 28 and 29 may be adjusted to provide for a greater or lesser number of picks per inch of material by shortening or lengthening the throw of the housings, respectively, as they impart movement to the clutches. As shown in FIGS. 3 and 4, the housings 24 for the eccentrics 23 are provided with elongate slots 24a for slidably receiving a pin 35 carried by an end of a bell crank 36, which is pivotally mounted on a shaft 37 in the frame 11 of the loom. An adjusting handle 38 is connected to the other end of the bell crank for pivoting it around shaft 37. In order to adjust and regulate the

number of picks per inch of material, the handle 38 is moved up or down, as desired, to lengthen or shorten the effective length of the housing 24 and thereby increase or decrease the distance the transport rolls move. It will be understood that the greater the travel imparted to the material by each operation of the transport rolls the less will be the number of picks per inch of material and conversely the shorter the travel of the material the greater will be the number of picks per inch.

Referring again to main drive shaft 12, a gear 39 (see FIG. 3) carried thereby drives a gear train assembly 40, which operates a plurality of eccentrics driven off the opposite ends of the assembly and moves them in timed cooperative relation. The eccentrics, as will be hereinafter explained, control the operation of a locking thread needle 41, looper 42 and crossover needle 43 and move them in timed cooperative relation with respect to the straight filling thread carrying needle 21.

As shown most clearly in FIGS. 3 through 7, an eccentric 44 having a housing 45 is connected at one side of the gear train assembly 40 and is driven by the gear 40a thereof mounted on a common shaft 44a. The operation of the eccentric 44 imparts a back and forth or rocking movement to the housing 45 which in turn is imparted to a crank 46. This rocking movement is then transmitted through a link 47 and a crank 47a to a locking needle and looper assembly 48 to reciprocate locking needle 41 and looper 42 in timed relation with the operation of straight needle 21 as it is reciprocated through the shed by the main drive shaft 12. As will be seen in FIG. 6, the locking thread needle and looper, which are each curved and travel in identical but opposed arcuate paths, are mounted on a rocker 49 in fixed relation relative to one another for cooperative operation as will be hereinafter explained and the link 47 is so connected to the rocker through crank 47a that the rocker is pivoted back and forth about shaft 50 to impart oscillating movement to the locking thread needle and looper.

An eccentric 51 having a housing 52 is also connected at the same side of gear train assembly 40 as is eccentric 44 and is driven through a square shaft 53 by the gear 40b of the assembly. The housing 52 of eccentric 51 is connected to a spring loaded arm 54 pivotally mounted on a shaft 55 carried by the frame 11 of the loom. The arm, which is provided with a relatively deep fork at its upper end, as at 56, is adapted to rotatably receive a shaft 57 disposed normal thereto and to move back and forth while maintaining the shaft in the fork. The shaft 57 has connected at one end thereof the mount 58 for the crossover needle 43 and the other end of the shaft extends through a portion of the frame 11 of the loom and has a washer or the like 59 forming a stop or abutment for a spring 60 which is mounted on the shaft and seats against the frame of the loom. Directing our attention now particularly to FIG. 7, it will be seen that the arm 54 is formed at its forked end, or that portion thereof which receives shaft 57, with a bevel or cam follower portion 61 which is adapted, on the arm 54 being rocked back and forth by eccentric housing 52, to engage a cam 61a which may be in the form of a bushing inserted in the frame 11 to serve as a bearing for shaft 57, for camming the arm and consequently the shaft 57 to the left, as seen in FIG. 1, against the force of spring 60, such movement of the arm serving a purpose to be hereinafter described. The movement of arm 54 to the left is communicated to the shaft 57 through thrust bearings 61b disposed between the arm and a member 63, in the form of a crank, connected to the shaft.

The eccentric 44, which has been heretofore described with respect to the operation of the locking thread needle and looper assembly 48, is provided with a second housing 62 which operates the crank 63 connected to crossover needle shaft 57 and serves to move the crossover needle 43 and the mount 58 thereof up and down in timed relation with the operation of filling thread carrying needle

21. It should here be noted that crank 63 will serve as an abutment to arm 54 when the latter is laterally shifted against spring 60 by the camming action heretofore described.

At this point it is noted that the crossover needle 43 is radially oscillated as the result of the movement imparted thereto from eccentric 44 through housing 62 and is shifted laterally back and forth as the result of the cam and spring action on shaft 57. The combined oscillating and lateral movement imparted to the crossover needle moves it in an elliptical path, as will be readily understood by those conversant with the weaving and sewing machine arts and will serve a purpose to be hereinafter more fully described.

The gear train assembly 40 has connected at the side thereof directed away from eccentrics 44 and 51 an eccentric 64 which is driven by the gear 40c of the assembly mounted on a common shaft 64a. The eccentric 64, which has a movement similar to the movement of eccentric 44 but with its frequency reversed, is provided with a housing 65 that transmits movement to the beat-up blades 66 (see FIG. 1) through a crank 67 and a beat-up blade shaft 68. As will be readily understood by those conversant with the weaving art, the beat-up blades are adapted to set the filling thread or weft in place prior to the harnesses changing position in the formation of the next shed.

The movement of the gear train assembly 40 is further taken up by meshing spur gears 69 and 70 which have a predetermined ratio and are driven by the engagement of spur gear 69 with gear 40b of the assembly. The spur gears 69 and 70 drive square shafts 71 and 72 which in turn drive eccentrics 73 and 74 that operate the harnesses or shed forming means 22. The square shafts are utilized to facilitate the precise timing of the harness motion. The eccentrics 73 and 74, as will be most clearly seen in FIG. 5, are provided, respectively, with housings 75 and 76 which move in a similar manner but with their frequencies reversed. The housings 75 and 76 operate bell cranks 77 and 78 which are pivoted respectively, on shafts 55 and 79. The bell cranks, as will be understood, shift the harnesses 22 up and down to form consecutive sheds through operating rods 80 and 81, the alternating up and down movements of the rods being controlled by the reversed position of the bell cranks 77 and 78. While in the illustrated form of the invention only two harnesses and operating means are shown and the spur gears depicted are of identical size, it will be understood that any desired number of harnesses may be utilized and the gearing means changed or appropriate cams inserted in the loom to facilitate weaving material having any desired pattern.

Referring now to FIGS. 8 through 11 for a description of a cycle in the operation of loom 10, as it relates to the formation of the far selvedge of the woven material, it will be seen that the straight filling thread needle 21 is projected into the shed formed by the shed forming means 22 from the near side thereof and carries a loop of filling thread 82 through the shed depositing it therein. While moving the loop of filling thread across the shed, the straight filling thread needle 21 passes through a loop of locking thread 83 carried by the curved locking thread needle 41 at a position adjacent and parallel to the far selvedge and carries the loop of filling thread with it (see FIG. 8). After the straight needle 21 has picked up the loop 83 of locking thread and just prior to the needle 21 being withdrawn from the shed for completion of the insertion of the loop of filling thread therein, the rocking of the locking thread needle and looper assembly 48 carries the looper 42 through the loop of filling thread 82 (see FIG. 9) thereby preventing displacement of the loop as straight needle 21 is withdrawn from the shed. Thereafter, as filling thread needle 21 clears the shed and beat-up blades 66 set the filling or weft thread loop 82 in place and the

harnesses change the shed for the next filling loop to be inserted by the straight needle 21, the needle looper 42, as a result of its travelling in the same arc as locking thread needle 41, transfers the loop 82 of filling thread carried thereby onto the locking thread needle 41 so that a loop 83a of locking thread is passed therethrough (see FIGS. 10 and 11). After the loop 82 of filling thread has been disposed on locking thread needle 41 and the loop 83a of locking thread has been pushed therethrough, the mechanism is in position to commence the next cycle of operation. After straight needle 21 is projected through the shed in the new cycle and has picked up the loop 83a of locking thread, and as the looper 42 moves into position to pick up the new loop of filling thread, the first loop of filling thread which is being carried by the locking thread needle 41 slips therefrom and passes between the tip of the locking thread needle and the tip of the looper. It will be seen that looper 42 is so constructed as to provide clearance as at 84 for the filling thread loop to be cast off the locking thread needle.

In FIG. 12 a cycle in the operation of the loom 10, as it relates to the weaving of the near selvedge is illustrated. As shown, a loop of crossover thread 85 carried by the crossover needle 43, which as afore-described is movable radially and laterally to define an elliptical path of travel, is formed parallel the near side of the shed and large enough to permit the straight filling thread carrying needle 21 to be projected therethrough as it deposits the loop of filling thread 82 in the shed. After the straight needle 21 is withdrawn from the shed and the loop of filling thread has been deposited therein, the crossover needle 43 will complete one elliptical path, wrapping the loop of crossover thread 85 previously formed, around the filling thread inserted in the shed by the needle 21 and thereafter will form another loop of crossover thread parallel to the first loop and laterally spaced therefrom at a predetermined distance defined by the camming action on crossover arm 54. It should here be understood that the movement of the woven material through the loom will cause the parallel spaced loops of crossover thread to fall substantially longitudinally one behind the other. According to the invention, one loop of crossover thread will be formed each time a loop of filling thread is deposited in the shed and consecutive crossover loops will be laterally spaced and parallel. By means of the lateral spacing between consecutive loops of crossover thread, one or a plurality of warp threads 86 may be locked in the near selvedge or a cord or other material may be woven into the near selvedge to achieve strengthening of the material or any fancy patterns desired.

Thus, among others, the several objects and advantages of the invention as aforementioned are achieved. Obviously numerous changes in the structure may be resorted to without departing from the spirit of the invention as defined by the claims.

I claim:

1. In a loom having shed-forming means; a mechanism for weaving the far and near selvages, said mechanism comprising means for carrying a loop of filling thread from the near side of said shed through said shed and depositing it therein, means for forming a loop of crossover thread adjacent the near side of said shed through which said loop of filling thread is passed as it is deposited in said shed, means for depositing a loop of locking thread on said filling thread carrying means adjacent the far side of said shed as the loop of filling thread is deposited therein, means adjacent the far side of said shed for picking up the loop of filling thread before the filling thread carrying means is withdrawn from said shed and depositing said loop of filling thread on said means for depositing said locking thread so that a loop of locking thread is passed therethrough, means for withdrawing said filling thread carrying means from said

shed, means for wrapping said loop of crossover thread around said loop of filling thread after said latter loop has been completely deposited in said shed and said means for carrying said filling thread has been withdrawn therefrom, means for forming a second loop of said crossover thread in a plane spaced from and beside said first loop thereof for receiving the next loop of filling thread and means for casting the first loop of filling thread off the means for depositing said locking thread when the means for picking up the loop of filling thread picks up the said second loop of filling thread deposited in said shed.

2. In a loom having shed-forming means; a mechanism for weaving the far selvedge, said mechanism comprising means for carrying a loop of filling thread through said shed and depositing it therein, means for depositing a loop of locking thread on said filling thread carrying means adjacent the far side of said shed as the loop of filling thread is deposited therein, means adjacent the far side of said shed for picking up the loop of filling thread before the filling thread carrying means is withdrawn from said shed and depositing said loop on said means for depositing said locking thread so that a loop of locking thread is passed therethrough and means for casting the filling thread loop off the means for depositing said locking thread loop when the means for picking up the loop of filling thread picks up the next loop thereof deposited in said shed.

3. In a loom having shed-forming means; a mechanism for weaving the near selvedge, said mechanism comprising means for carrying a loop of filling thread from the near side of said shed through said shed and depositing it therein, means for forming a loop of crossover thread adjacent the near side of said shed through which a complete loop of filling thread is received as it is deposited in said shed, and means for forming a second loop of said crossover thread in a parallel plane spaced from and beside said first loop thereof for receiving the next complete loop of filling thread.

4. In a loom having shed-forming means; a mechanism for weaving the far selvedge, said mechanism comprising a straight needle having an eye for carrying a filling thread positioned at the near side of said shed, means for projecting and withdrawing said straight needle transversely through said shed for depositing a loop of filling thread therein, a locking thread needle having an eye for carrying a locking thread movably mounted adjacent the far side of said shed, means for moving said locking thread needle for depositing a loop of locking thread on said straight needle as said straight needle is projected through said shed and said loop of filling thread is deposited therein, a needle-looper mounted for movement adjacent the far side of said shed, means for moving said needle-looper for picking up the loop of filling thread before said straight needle is withdrawn from said shed and depositing said loop of filling thread on said locking thread needle so that a loop of locking thread is passed therethrough and means for casting the filling thread loop off said locking thread needle when said needle-looper picks up the next loop of filling thread deposited in said shed by said straight needle.

5. In a loom having shed-forming means; a mechanism for weaving the far selvedge, said mechanism comprising a straight needle having an eye for carrying a filling thread positioned at the near side of said shed, means for projecting and withdrawing said straight needle transversely through said shed for depositing a loop of filling thread therein, a locking thread needle having an eye for carrying a locking thread movably mounted adjacent the far side of said shed, means for moving said locking thread needle for depositing a loop of locking thread on said straight needle as said straight needle is projected through said shed and said loop of filling thread is deposited therein, a needle-looper mounted for movement in the same plane as said locking thread needle and in

7

the opposite direction, means for moving said needle-looper for picking up the loop of filling thread before said straight needle is withdrawn from said shed and depositing said loop of filling thread on said locking thread needle so that a loop of locking thread is passed therethrough and means for casting the filling thread loop off said locking thread needle when said needle-looper picks up the next loop of filling thread deposited in said shed by said straight needle.

6. In a loom having shed-forming means; a mechanism for weaving the far selvage, said mechanism comprising a straight needle having an eye for carrying a filling thread positioned at the near side of said shed, means for projecting and withdrawing said straight needle transversely through said shed for depositing a loop of filling thread therein, a curved locking thread needle having an eye for carrying a locking thread pivotally mounted for movement in an arc adjacent and parallel to the far side of said shed, means for moving said curved needle in said arc for depositing a loop of locking thread on said straight needle as said straight needle is projected through said shed and said loop of filling thread is deposited therein, a needle-looper mounted for movement adjacent the far side of said shed and in a direction opposed to the path of said curved needle, means for moving said needle-looper for picking up the loop of filling thread before said straight needle is withdrawn from said shed and depositing said loop of filling thread on said curved needle so that a loop of locking thread is passed therethrough and means for casting the filling loop off said curved needle when said needle-looper picks up the next loop of filling thread deposited in said shed by said straight needle.

7. In a loom having shed-forming means; a mechanism for weaving the far selvage, said mechanism comprising a straight needle having an eye for carrying a filling thread positioned at the near side of said shed, means for projecting and withdrawing said straight needle transversely through said shed for depositing a loop of filling thread therein, a curved locking thread needle having an eye for carrying a locking thread pivotally mounted for movement in an arc adjacent and parallel to the far side of said shed, means for moving said curved needle in said arc for depositing a loop of locking thread on said straight needle as said straight needle is projected through said shed and said loop of filling thread is deposited therein, a curved needle-looper pivotally mounted for movement in the same arc as said curved needle and in a direction opposed to the path of said curved needle, means for moving said needle-looper in said arc for picking up the loop of filling thread before said straight needle is withdrawn from said shed and depositing said loop of filling thread on said curved needle so that a loop of locking thread is passed therethrough and means for casting the filling loop off said curved needle when said needle-looper picks up the next loop of filling thread deposited in said shed by said straight needle.

8. In a loom having a main drive shaft and shed-forming means; a mechanism for weaving the far selvage, said mechanism comprising a straight needle having an eye for carrying a filling thread positioned at the near side of said shed, means for connecting said straight needle to said main drive shaft to be driven thereby for projecting and withdrawing said straight needle transversely through said shed for depositing a loop of filling thread therein, a curved locking thread needle having an eye for carrying a locking thread pivotally mounted for movement in an arc parallel to the far side of said shed, means for connecting said curved needle to said main drive shaft for moving said curved needle in said arc in predetermined timed relation to the operation of said straight needle for depositing a loop of locking thread on said straight needle as said straight needle is projected through said shed and said loop of filling thread is deposited therein, a curved needle-looper pivotally mounted for movement in the same arc as said curved needle and

8

in a direction opposed to the path of said curved needle, means for connecting said needle-looper to said main drive shaft for moving said needle-looper in said arc simultaneously with said curved needle for picking up the loop of filling thread before said straight needle is withdrawn from said shed and depositing said loop of filling thread on said curved needle so that a loop of locking thread is passed therethrough and means for casting the filling loop off said curved needle when said needle-looper picks up the next loop of filling thread deposited in said shed by said straight needle.

9. The invention as defined in claim 8, in which said curved locking thread needle and said needle-looper are carried by a rocking member pivotally mounted parallel and adjacent to the far side of said shed, and in which the means for moving said curved needle and said needle-looper in timed relation to the operation of said straight needle comprises means eccentrically connecting said rocking member to said main drive shaft to be rocked thereby.

10. In a loom having shed-forming means; a mechanism for weaving the far selvage, said mechanism comprising a straight needle having an eye in the free end thereof for carrying a filling thread positioned at the near side of said shed, means for projecting and withdrawing said straight needle transversely through said shed for depositing a loop of filling thread therein, a curved locking thread needle having an eye in the free end thereof for carrying a locking thread pivotally mounted for movement in an arc parallel to the far side of said shed, means for moving said curved needle in said arc for depositing a loop of locking thread on said straight needle as said straight needle is projected through said shed and said loop of filling thread is deposited therein, a curved needle-looper pivotally mounted for movement in the same arc as said curved needle and in the opposite direction and having the leading end thereof overlying the free end of said curved needle, and means for moving said needle-looper in an arc for picking up the loop of filling thread before said straight needle is withdrawn from said shed and depositing said loop of filling thread on said curved needle so that a loop of locking thread is passed therethrough, said curved needle casting off said loop of filling thread when said needle-looper picks up the next loop of filling thread deposited in said shed by said straight needle.

11. The invention as defined in claim 10, in which the leading edge of said needle-looper is undercut to facilitate the casting off of said loop of filling thread from said curved locking thread needle.

12. In a loom having shed-forming means; a mechanism for weaving the near selvage, said mechanism comprising a straight needle having an eye for carrying a filling thread positioned at the near side of said shed, means for projecting and withdrawing said straight needle transversely through said shed for depositing a loop of filling thread therein, a crossover needle having an eye for carrying a crossover thread mounted adjacent the near side of said shed, means for passing said crossover needle through said shed for providing a loop of crossover thread through which a complete loop of filling thread is received as it is deposited in said shed and said straight needle is withdrawn and means for moving said crossover needle so that the next crossover loop passed through said shed is formed in a plane parallel to and spaced from the first loop thereof for receiving the next complete loop of filling thread.

13. In a loom having shed-forming means; a mechanism for weaving the near selvage, said mechanism comprising a straight needle having an eye for carrying a filling thread positioned at the near side of said shed, means for projecting and withdrawing said straight needle transversely through said shed for depositing a loop of filling thread therein, a crossover needle having an eye for carrying a crossover thread mounted adjacent the

9

near side of said shed, means for passing said crossover needle through said shed transversely of the path of travel of said straight needle for providing a loop of crossover thread through which a complete loop of filling thread is received as it is deposited in said shed and said straight needle is withdrawn and means for moving said crossover needle so that the next crossover loop passed through said shed is formed in a plane parallel to and spaced from the first loop thereof for receiving the next complete loop of filling thread.

14. In a loom having shed-forming means; a mechanism for weaving the near selvage, said mechanism comprising a straight needle having an eye for carrying a filling thread positioned at the near side of said shed, means for projecting and withdrawing said straight needle transversely through said shed for depositing a loop of filling thread therein, a curved crossover needle having an eye for carrying a crossover thread pivotally mounted adjacent the near side of said shed, means for passing said crossover needle through said shed transversely of the path of travel of said straight needle for providing a loop of crossover thread through which a complete loop of filling thread is received as it is deposited in said shed and said straight needle is withdrawn and means for laterally moving said crossover needle so that the next crossover loop passed through said shed is formed in a plane parallel to and spaced from the first loop thereof for receiving the next complete loop of filling thread.

15. In a loom having a main drive shaft and shed-forming means; a mechanism for weaving the near selvage, said mechanism comprising a straight needle having an eye for carrying a filling thread positioned at the near side of said shed, means for connecting said straight needle to said main drive shaft to be driven thereby for projecting and withdrawing said straight needle transversely through said shed for depositing a loop of filling thread therein, a curved crossover needle having an eye for carrying a crossover thread pivotally mounted adjacent the near side of said shed, means eccentrically connected to said main drive shaft for moving said crossover needle back and forth through said shed transversely

10

of the path of travel of said straight needle in predetermined timed relation to the operation of said straight needle for providing a loop of crossover thread through which a complete loop of filling thread is received as it is deposited in said shed and said straight needle is withdrawn and means eccentrically connected to said main drive shaft for laterally moving said crossover needle in timed relation to the operation of said straight needle so that the next crossover loop passed through said shed is formed in a plane parallel to and spaced from the first loop thereof for receiving the next complete loop of filling thread.

16. The invention as defined in claim 15, wherein said curved crossover needle is carried by a rotatable shaft, and in which said means for moving said needle back and forth through said shed comprise a crank arm connected to said shaft for rotating the same and eccentric means connecting said crank arm to said main drive shaft for rocking the same to rotate said shaft and move said crossover needle in timed relation to the operation of said straight needle.

17. The invention as defined in claim 16, in which said shaft for carrying said crossover needle is axially movable, and in which said means for laterally moving said crossover needle comprises means for camming said shaft for axially moving the same and eccentric means connecting said cam means to said main drive shaft for operating said cam means and laterally shifting said crossover needle in timed relation to the operation of said straight needle.

References Cited in the file of this patent

UNITED STATES PATENTS

862,056	Dalkranian	July 30, 1907
2,561,416	Robinson	July 24, 1951
2,742,932	Libby	Apr. 24, 1956
2,777,470	Vallaguzza	Jan. 15, 1957

FOREIGN PATENTS

142,555	Germany	June 27, 1902
---------	---------	---------------