

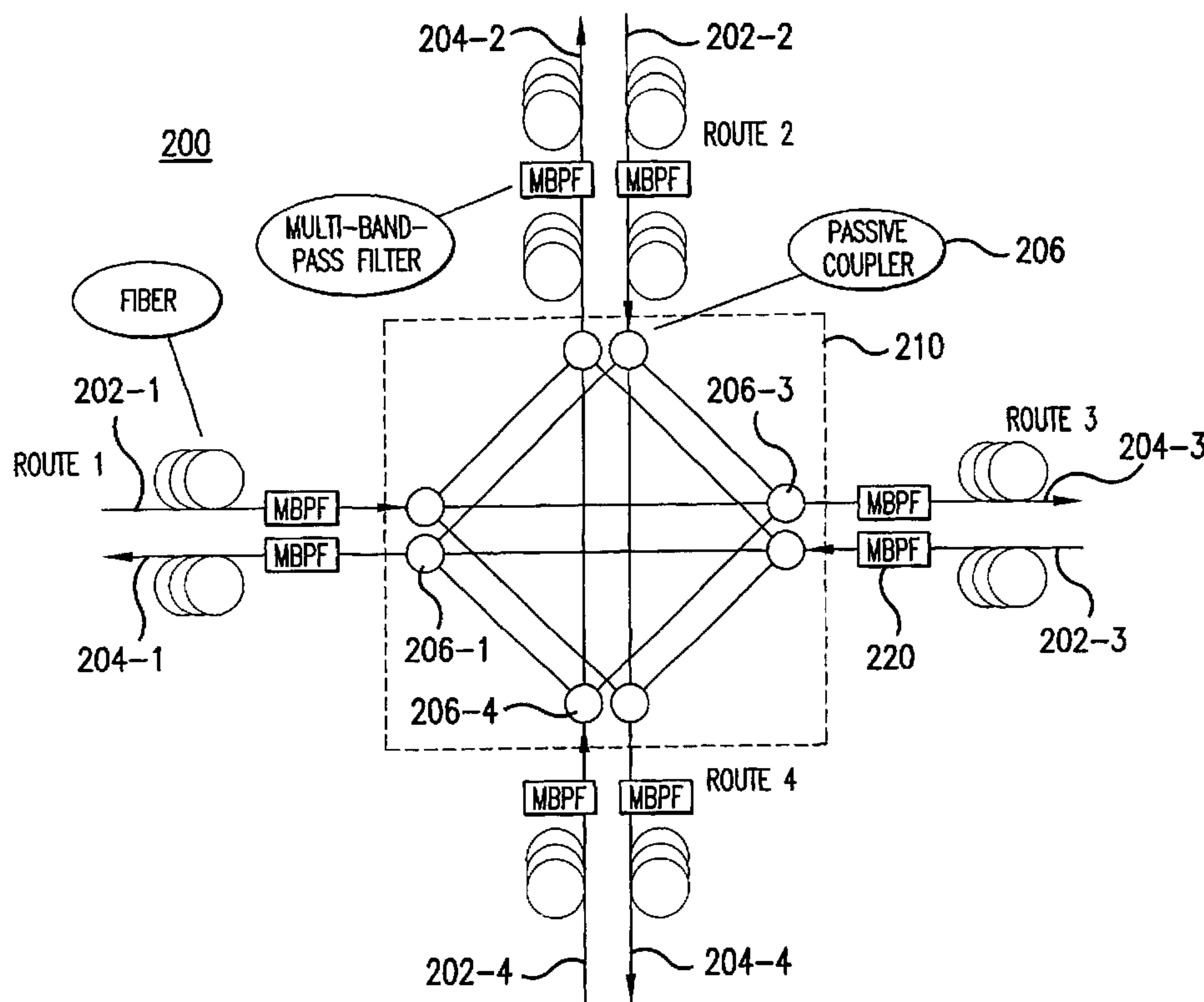

(86) Date de dépôt PCT/PCT Filing Date: 2003/09/16
 (87) Date publication PCT/PCT Publication Date: 2004/03/25
 (85) Entrée phase nationale/National Entry: 2005/03/15
 (86) N° demande PCT/PCT Application No.: US 2003/028757
 (87) N° publication PCT/PCT Publication No.: 2004/025330
 (30) Priorité/Priority: 2002/09/16 (60/411,007) US

(51) Cl.Int.⁷/Int.Cl.⁷ G02B 6/28
 (71) Demandeur/Applicant:
CIENA CORPORATION, US
 (72) Inventeurs/Inventors:
FRANKEL, MICHAEL Y., US;
BERTHOLD, JOSEPH, US
 (74) Agent: KIRBY EADES GALE BAKER

(54) Titre : BRASSEUR OPTIQUE ET PROCEDE ASSOCIE
 (54) Title: OPTICAL CROSS CONNECT APPARATUS AND METHOD



(57) Abrégé/Abstract:

A new architecture is proposed for making optical cross connect (200) in wavelength division multiplexed networks. The value of optical networks incorporating all-optical cross connects (210) is typically associated with being able to selectively route individual channel wavelengths through several network nodes without performing optical-electrical and electrical-optical conversion. From a network perspective, most work on the optical cross connect architectures (210, 202, 204, 220) have been concentrated on the highest possible capability for the cross-connect itself. The problem with considering optical cross connect architectures (210) in isolation without attention to the rest of the network may lead to unnecessarily complicated hardware. In the proposed architecture, considers the network as a whole and significant cost reductions as well as complexity reductions are realized.

(12) INTERNATIONAL APPLICATION PUBLISHED UNDER THE PATENT COOPERATION TREATY (PCT)

(19) World Intellectual Property
Organization
International Bureau



(43) International Publication Date
25 March 2004 (25.03.2004)

PCT

(10) International Publication Number
WO 2004/025330 A3

- (51) International Patent Classification⁷: **G02B 6/28**
- (21) International Application Number:
PCT/US2003/028757
- (22) International Filing Date:
16 September 2003 (16.09.2003)
- (25) Filing Language: English
- (26) Publication Language: English
- (30) Priority Data:
60/411,007 16 September 2002 (16.09.2002) US
- (71) Applicant: **CIENA CORPORATION** [US/US]; Legal Department, 1201 Winterson Road, Linthicum, MD 21090 (US).
- (72) Inventors: **FRANKEL, Michael, Y.**; 7221 Brookfalls Terrace, Baltimore, MD 21209 (US). **BERTHOLD, Joseph**; 1201 Winterson Road, Linthicum, MD 21090 (US).
- (74) Agent: **CAMMARATA, Michael, R.**; Birch, Stewart, Kolasch & Birch, LLP, P.O. Box 747, Falls Church, VA 22040-0747 (US).
- (81) Designated States (*national*): AE, AG, AL, AM, AT, AU, AZ, BA, BB, BG, BR, BY, BZ, CA, CH, CN, CO, CR, CU, CZ, DE, DK, DM, DZ, EC, EE, EG, ES, FI, GB, GD, GE, GH, GM, HR, HU, ID, IL, IN, IS, JP, KE, KG, KP, KR, KZ, LC, LK, LR, LS, LT, LU, LV, MA, MD, MG, MK, MN, MW, MX, MZ, NI, NO, NZ, OM, PG, PH, PL, PT, RO, RU, SC, SD, SE, SG, SK, SL, SY, TJ, TM, TN, TR, TT, TZ, UA, UG, UZ, VC, VN, YU, ZA, ZM, ZW.
- (84) Designated States (*regional*): ARIPO patent (GH, GM, KE, LS, MW, MZ, SD, SL, SZ, TZ, UG, ZM, ZW), Eurasian patent (AM, AZ, BY, KG, KZ, MD, RU, TJ, TM), European patent (AT, BE, BG, CH, CY, CZ, DE, DK, EE, ES, FI, FR, GB, GR, HU, IE, IT, LU, MC, NL, PT, RO, SE, SI, SK, TR), OAPI patent (BF, BJ, CF, CG, CI, CM, GA, GN, GQ, GW, ML, MR, NE, SN, TD, TG).
- Published:**
— with international search report
— before the expiration of the time limit for amending the claims and to be republished in the event of receipt of amendments
- (88) Date of publication of the international search report:
19 August 2004

[Continued on next page]

(54) Title: OPTICAL CROSS CONNECT APPARATUS AND METHOD

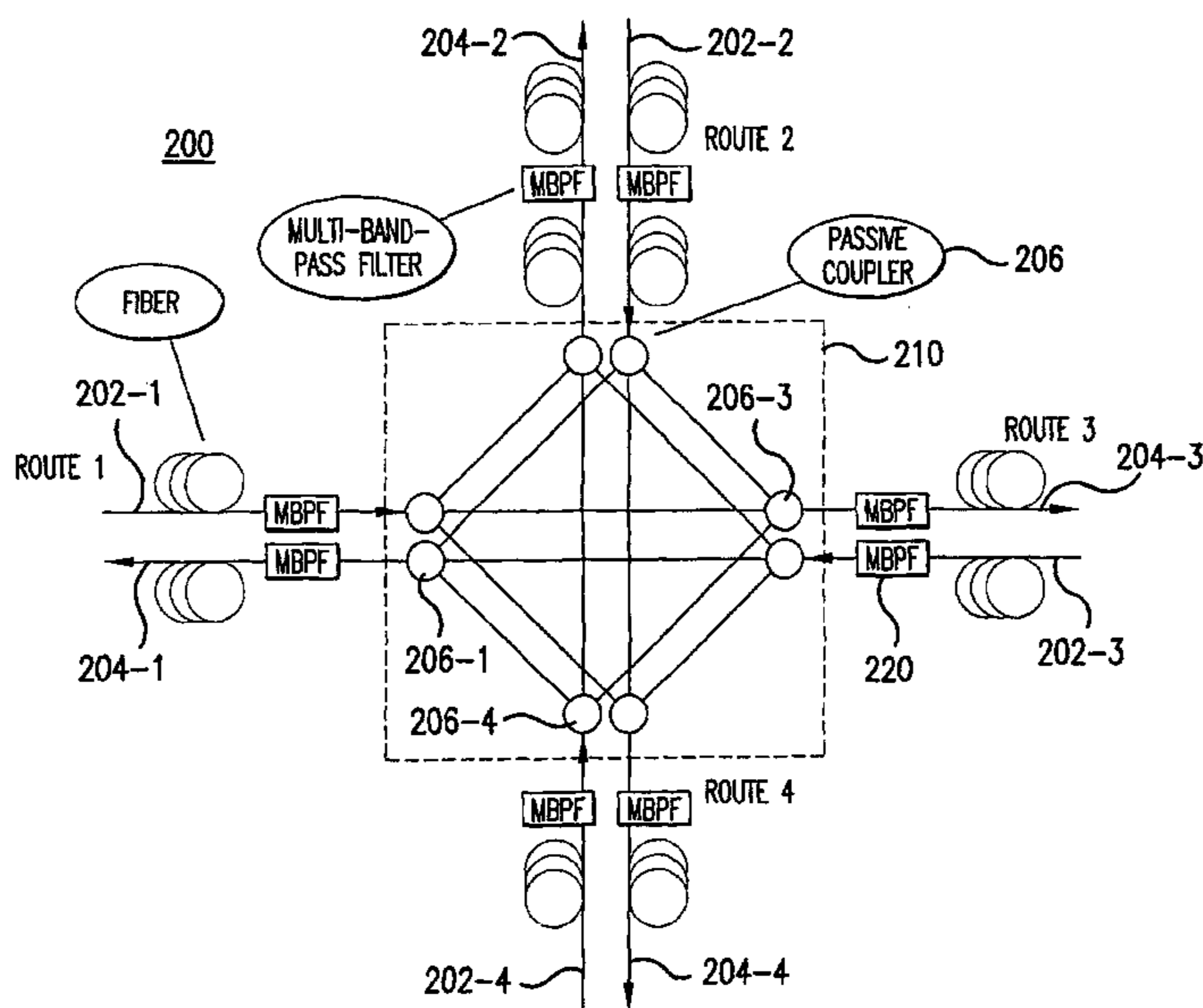

(57) **Abstract:** A new architecture is proposed for making optical cross connect (200) in wavelength division multiplexed networks. The value of optical networks incorporating all-optical cross connects (210) is typically associated with being able to selectively route individual channel wavelengths through several network nodes without performing optical-electrical and electrical-optical conversion. From a network perspective, most work on the optical cross connect architectures (210, 202, 204, 220) have been concentrated on the highest possible capability for the cross-connect itself. The problem with considering optical cross connect architectures (210) in isolation without attention to the rest of the network may lead to unnecessarily complicated hardware. In the proposed architecture, considers the network as a whole and significant cost reductions as well as complexity reductions are realized.

WO 2004/025330 A3



For two-letter codes and other abbreviations, refer to the "Guidance Notes on Codes and Abbreviations" appearing at the beginning of each regular issue of the PCT Gazette.

OPTICAL CROSS CONNECT APPARATUS AND METHOD

PROVISIONAL APPLICATION

The present application claims priority under 35 U.S.C. § 120 of a
5 provisional application 60/411,007 filed on September 16, 2002, the
entirety of which is hereby incorporated by reference.

FIELD OF THE INVENTION

The field of the invention generally relates to optical cross connects,
10 methods of forming optical cross connects, and related optical networking
architectures and methods. More particularly, the invention relates to a
new architecture and method for an optical cross connect that is
particularly useful in wavelength division multiplexed networks.

15 BACKGROUND OF THE INVENTION

The value of optical networks incorporating all-optical cross connects
(OCC) is typically associated with being able to selectively route individual
channel wavelengths through several network nodes without performing
optical-electrical and electrical-optical conversion.

20 From a network perspective, most research on the OCC architectures
have been concentrated on the highest possible capability for the cross-
connect itself. For example, switch architectures with single wavelength
granularity and fully non-blocking capability are considered indispensable
to optical networks and have, therefore, been a subject of intense research.
25 The term "non-blocking" refers to an ability of the optical switch to direct

any spectral input to any output without precluding (or "blocking") any of the possible connections for other spectral inputs and outputs.

Typical OCC designs include:

- 5 (i). a spectral DEMUX on each input fiber, followed by a space-division switch, followed by a MUX or combiner to direct the selectively-switched wavelengths to output fibers;
- (ii). a passive splitter after each input fiber, an optical filter on each split path, a space-division switch, followed by a combiner to direct filtered and selectively switched wavelengths to output
10 fibers; and
- (iii). a passive splitter after each input fiber, a filter on each split path, and a combiner to direct filtered wavelengths to output
15 fibers.

Figure 1 illustrates a conventional "broadcast and select" OCC apparatus 100 of architecture of (iii) as described. In particular, Figure 1
15 illustrates a fully non-blocking OCC. In this OCC architecture, $N*(N-1)$ filters are required for cross-connecting N diverse routes.

The conventional OCC apparatus 100 includes a plurality of optical inputs 102 a plurality of optical outputs 104. The conventional OCC
20 apparatus 100 apparatus also includes local cross-connect 110 used for cross connecting the optical inputs 102 and outputs 104 so that optical signals flowing into the optical inputs 102 are directed to the appropriate optical outputs 104.

The local cross-connect 110 itself includes a plurality of optical
25 couplers 106 and a plurality of optical filters 120 optically placed between

each connected pair of optical couplers 106. As seen, depending on the placement, each optical coupler 106 performs one of two functions - splitting the incoming optical signal for outputting to other optical coupler or combining optical signals from other optical couplers and outputting the
5 outgoing optical signal.

In the example shown in Figure 1, there are 4 diverse routes. Cross-connecting the 4 routes requires 12 optical filters. Increasing the route by one to total 5 requires eight additional filters to total 20. In short, the fabric of the conventional OCC architecture requires $N*(N-1)$ filters. In other
10 words, the increase is quadratic.

Generally, the conventional OCC architectures have optical signal flows that may be described as follows:

- (1) split the incoming optical signal;
- (2) perform optical filtering and/or switching; and
- 15 (3) recombine optical signals into output filters.

This is shown in Figure 1 where there is an optical filter 120 after each split and before each recombine. Such design necessarily constrains the OCC to an effectively "localized" architecture since the optical processing is sandwiched between the splitter and combiner functions. Localization
20 occurs when all of the optical switch components are required to be located at a single physical location in the network.

This localization, while perhaps enabling to maximize the capability of the OCC node itself, may not be required or needed for the network, which the OCC node is a part of, as a whole. Further, it may lead to unnecessarily

complicated hardware and connections that make up the network, thereby increasing its cost.

BRIEF DESCRIPTION OF THE DRAWINGS

5 Features of the present invention will become more fully understood to those skilled in the art from the detailed description given hereinbelow with reference to the drawings, which are given by way of illustrations only and thus are not limitative of the invention, wherein:

10 Figure 1 is a block diagram illustrating a conventional optical cross connect architecture;

Figure 2 is a block diagram illustrating an optical cross connect architecture according to an embodiment of the present invention;

Figure 3 is a block diagram illustrating an optically cross-connected fiber ring network according to an embodiment of the present invention;

15 Figure 4 is a block diagram illustrating a mesh-type optical cross connect network according to an embodiment of the present invention;

20 Figure 5 is a series of illustrations demonstrating how the multi-band-pass filter count drops as model network's transport system capacity increases by applying an embodiment of a technique of the present invention;

Figure 6 is a series of illustrations demonstrating how the multi-band-pass filter count drops as an actual example network's transport system capacity increases by applying an embodiment of a technique of the present invention;

Figures 7a-b are block diagrams illustrating different embodiments of multi-band-pass filters according to the present invention; and

Figure 8 illustrates a method of cross-connecting a plurality of optical inputs and outputs according to an embodiment of the present invention.

5

DETAILED DESCRIPTION

For simplicity and illustrative purposes, the principles of the present invention are described by referring mainly to exemplary embodiments thereof. The same reference numbers and symbols in different drawings identify the same or similar elements. Also, the following detailed description does not limit the invention. The scope of the invention is defined by the claims and equivalents thereof.

The expression “optically communicates” as used herein refers to any connection, coupling, link or the like by which optical signals carried by one optical element are imparted to the “communicating element.” Such “optically communicating” devices are not necessarily directly connected to one another and may be separated by intermediate optical components and/or devices. Likewise, the expressions “connection”, “operative connection”, and “optically placed” as used herein are relative terms and do not necessarily require a direct physical connection.

In general, an aspect of the present invention may be described having optical flows in different sequence as compared to the conventional optical cross-connection apparatus as follows:

- (1) optical filtering one or more input optical signals, while still keeping filtered signal in a single transmission medium;

25

- (2) cross-connecting between one or more inputs and one or more outputs; and
- (3) optical filtering one or more output optical signals.

The cross connecting may be performed in a spectrally transparent
5 manner. This process "localizes" only the cross-connection function and the
optical filtering may be removed from the cross-connect. The optical filtering
may be performed at the apparatus itself, by other nodes in the network, or
not at all. Because the optical filtering is not constrained to the OCC, the
filtering functionality becomes "distributed" on the network. The entire
10 network may be considered to thereby increase efficiency and performance
and reduce complications and costs.

Figure 2 is a block diagram illustrating an optical cross-connect
apparatus 200 according to an embodiment of the present invention. As
shown, the optical cross-connect apparatus 200 may include a plurality of
15 optical inputs 202-n, a plurality of optical outputs 204-n, an OCC 210
provided between the plurality optical inputs 202-n and outputs 204-n, and
a plurality of optical filters 220 provided outside of the OCC 210. In this
instance, n is from 1 to 4 for each of the routes, but it should be understood
that the number of routes is not so limited.

20 By providing the optical filters 220 outside of the OCC 210, only the
cross-connection function is localized as noted above. The example in
Figure 2 shows that between each optical input 202-n and the OCC 210 and
also between each optical output 204-n and the OCC 210, an optical filter
220 is optically placed. Thus, Figure 2 is an example of optical filtering (or

processing) taking place within the optical cross-connect apparatus 200 itself.

However, it is to be understood that the optical cross-connect apparatus 200 is not so limited. While Figure 2 illustrates so, it is not
5 necessary that an optical filter 220 be optically connected to each and every optical input 202-n and output 204-n within the apparatus. Indeed, it is not necessary to have any optical filters within the apparatus 200 at all. As indicated above, optical filtering may be performed by other nodes in the network (i.e. "distributed") or not at all.

10 The OCC 210 may be spectrally transparent. In other words, the OCC 210 itself does not perform any spectrum (wavelength) blocking functions. If blocking functions are desired or required, they may be performed by appropriately placing one or more optical filters 220, either within the apparatus 200 or within the network outside of the apparatus 200.

15 The OCC 210 may include a plurality of optical couplers 206-m appropriately placed and connected to perform optical splitting and combining functions so that optical signals may be directed as desired. One or more of the optical couplers 206-m may be passive optical couplers. It is to be noted that m is 1 to the actual number of couplers within the OCC 210
20 (in this instance, 8) to uniquely identify each coupler. For brevity and for ease of explanation, not all optical couplers are so numbered.

Also, one or more of the optical filters 220 may be a multi-band-pass type filter 700a as shown in Figure 7a. As shown, the multi-band-pass filter (MBPF) 700a receives as optical input a spectrum of wavelengths
25 represented by the symbol λ . These wavelengths may be viewed as a single

optical channel or bands of optical channels where each channel is capable of carrying separate optical information. The MBPF 700a blocks a subset of the channels and outputs the remainder (or complementary set) of the channels of the spectrum. Figure 7b illustrates a reconfigurable MBPF (RMBPF) 700b wherein the particular channel or channels blocked may be chosen through control signals. A description of a particular type of RMBPF may be found in a provisional application ___/___,___, Attorney Docket 4450-0403P, filed on August 4, 2003 by the common Assignee of the present application and is hereby incorporated by reference in its entirety.

When the optical filtering function takes place outside the optical cross-connect fabric such as shown in Figure 2, the maximum number of optical filters required is $2*N$ for cross-connecting N diverse routes. In other words, the increase is order N , i.e. linear. This makes increasing the number of routes for a cross-connect more practical, which in turn enables more cost-effective and capable networks to be designed.

A method of cross-connecting the plurality of optical inputs 202-n and plurality of optical outputs 204-n may be described as follows. Figure 8 illustrates an embodiment of such a method. As shown, the method 800 may include a step 810 of providing an optical cross-connect between a plurality of optical inputs. The method 800 may also include a step 820 of optically filtering at least one optical channel of an optical signal flowing into at least one of the inputs or flowing out of at least one of the outputs or both. The optical cross-connect may be spectrally transparent and filtering may be channel or band-pass filtering.

An embodiment of the optical cross-connect apparatus may be described as follows. Referring back to Figure 2, it is noted that the optical cross-connect 210 forms paths between the optical inputs 202-n and outputs 204-n. For example, the optical couplers 206-4 and 206-3 enables
5 a path (or connection) to be formed between the optical input 202-4 and the optical output 204-3. Likewise, the optical couplers 206-4 and 206-1 enables another path to be formed between the optical input 202-4 and the optical output 204-3. In the example illustrated in Figure 2, a path is formed between each optical input 202-n and each optical output 204-n.
10 However, it is not necessary that a path be formed for each and every pair of optical inputs 202-n and outputs 204-n.

Also in the example illustrated in Figure 2, the plurality of optical filter 220 is provided outside the cross-connect 210 such that each path is filtered at its input and output. However, it is not necessary that each path be
15 filtered at both input and output. Indeed, it is not necessary that any of the paths within the apparatus 200 be filtered at all. This is because optical filtering may be performed by other nodes in the network or not at all. If it is desired that each path be filtered within the apparatus 200, either the input of the path or the output of the path or both may be filtered.

20 Figure 3 is a block diagram illustrating an optically cross-connected fiber ring network 300 according to an embodiment of the present invention.

Subsequent description refers to single wavelengths (λ_1 , λ_2 , etc.) for ease of explanation, but it is to be understood that the same could be taken as specific wavelength bundles or bands.

The network 300 may include an outer ring 302 and an inner ring 304. The outer ring 302 carries optical signals in a clockwise direction and the inner ring 304 carries optical signals in a counter-clockwise direction, but they can be vice versa. The network 300 may also include an optical
5 cross-connect apparatus 310, of the type illustrated in Figure 2. The apparatus 310 enables outer-to-out and inner-to-inner connections. While not shown, it is to be understood that other connections are possible, such as outer-to-inner and inner-to-outer.

If a conventional optical cross-connect apparatus such as illustrated
10 in Figure 1 is used, such a cross-connection would require 12 optical filters for a fully populated OCC resulting in a more complicated hardware. In this embodiment, no optical filters are required at the apparatus 310. The optical filtering may be absorbed or moved to adjacent ring nodes 306 as shown. It may be the case that one or more optical filters 308 are required
15 for other purposes regardless, and this embodiment allows efficient utilization of the existing filters. Of course, the optical cross connect apparatus 310 may also include optical filters as well.

While not explicitly shown in Figure 3, a control component may be included. More specifically, the optical filters 308 may be controlled so as to
20 reconfigurably block/pass desired channel or groups of channels. A conventional service channel, overlay IP network, DCC or other communication means may be used to communicate administrative, maintenance, and control information to further enable such a functionality.

In addition, the embodiment illustrated in Figure 3 supports optically
25 protected intra-ring connections such as λ_1 and λ_3 . The subscripts "w", "p",

and “unp” refer to working, protected, and unprotected wavelength channels, respectively. It should be noted that protected wavelength cannot be reused among rings. For example, λ_{1p} and λ_{3p} are used only in the upper rings and the lower rings, respectively. Unprotected intra-ring
5 connections may reuse wavelengths. For example, λ_{2unp} is used in both upper and lower rings.

The same holds true for inter-ring connections where full optical protection requires that 2 wavelengths be used (λ_4 and λ_5) in this example. Unprotected connection can still be accomplished with a single wavelength.

10 In networks that have wavelength-addressable nodes (i.e. a node that has a unique set of wavelengths associated with it), for example the networks that support laser-wavelength connectivity, the above compromise on wavelength reuse is removed. The bandwidth limitation would be the same regardless of the particular OCC architecture.

15 Figure 4 is a block diagram illustrating a mesh-type optical cross connect network 400 according to an embodiment of the present invention. As shown, the network 400 may include a plurality of optical inputs 402, a plurality of outputs 404, an optical cross-connect 410, a plurality of optical filters 420, and an optical add/drop module (OADM) 430 with its own
20 optical filters 432. As connected, route 1 is part of a linear optical subnetwork. In this example, the OADM 430 includes first and second optical filters 432 optically connected to an optical input 402 and to an optical output 404, respectively.

In this view, the total bandwidth required to be accessible by the
25 optical transport system is the sum of all bandwidth connections.

Conventional OCC require total bandwidth to be maximum of the sum at each route independently. At a first glance, the network 400 may appear to be wasteful when compared to the conventional OCC. However, the following points should be noted:

- 5 1. The bandwidth utilization differences between distributed and conventional architectures decrease as interconnect traffic become more asymmetric.
2. If each bi-directional connection is required to be made with same wavelengths (same channels), conventional OCC is
10 penalized and becomes identical to some embodiments of the present invention.
3. The bandwidth that is not used for route interconnection at an OCC can be still recovered and used for "local" intra-route connections.
- 15 4. As route demand exceeds a single line system capacity, a parallel line system may need to be tuned up. This increases the degree of all nodes along that route by one, thus increasing their complexity. Regardless of the OCC architecture, this
 produces substantial wavelength blocking.

20 Figures 5 and 6 illustrate two example networks that illustrate that optical filtering can be approached in a "distributed" fashion according to various embodiments of the present invention. Rather than consider each OCC node in isolation, optical filter locations are determined based on the total network topology and traffic demands. Thus, optical filtering becomes
25 distributed. These figures illustrate the considerable simplification of OCC

nodes, which thereby reduces network costs. It should be noted that as the line system capacity increases, the network requirement for wavelength reuse decrease, corresponding to a decreased number of required MBPF modules.

5 Referring to Figures 5 and 6, each node in the network is uniquely numbered, and shown by a "*" on the plots. A PATH lists node pairs that have physical connectivity between each other, which is also shown by solid lines on the network plots. A DEMAND lists two node numbers and a total traffic channel demands flowing between these two nodes. It should be
10 noted that physical PATHs and DEMANDs are independent. Circle on the plots indicate nodes that contain optical filters (MBPF). The results illustrate that as the capacity of the optical transmission systems increase, networks need progressively decreasing numbers of optical filters. Generally, optical filters allow for spectral re-use in a network, which is only
15 needed if total network traffic demand exceeds transmission system capacity.

While the invention has been described with reference to the exemplary embodiments thereof, it is to be understood that various modifications may be made to the described embodiments without departing
20 from the spirit and scope of the invention thereof. The terms as descriptions used herein are set forth by way of illustration only and are not intended as limitations.

What is claimed is:

1. An optical cross-connect apparatus (200), comprising:
a plurality of optical inputs (202-n);
a plurality of optical outputs (204-n);
an optical cross-connect (210) provided between said plurality of optical inputs (208) and said plurality of optical outputs (210); and
at least one optical filter (220) provided outside of said cross-connect (210), said at least one optical filter (220) filtering at least one optical channel of an optical signal flowing into at least one of said plurality of optical inputs (208) or filtering at least one optical channel of an optical signal flowing out of at least one of said plurality of optical outputs (210) or both.
2. The optical cross-connect apparatus (200) of claim 1, wherein said optical cross-connect (210) includes:
optical splitters (206-m) optically coupled to said optical inputs (202-n); and
optical combiners (206-m) optically coupled to said optical outputs (204-n),
wherein said optical splitters (206-m) are optically coupled to said optical combiners (206-m) in a broadcast and combine arrangement.
3. The optical cross-connect apparatus (200) of claim 2, wherein each optical input (202-n) is optically coupled to a respective one of said

optical splitters (206-m) and each optical output (204-n) is optically coupled to a respective one of said optical combiners (206-m).

4. The optical cross-connect apparatus (200) of claim 1, wherein there are no optical filters included within said optical cross-connect (210).

5. The optical cross-connect apparatus (200) of claim 1, wherein the optical cross-connect (210) is spectrally transparent.

6. The optical cross-connect apparatus (200) of claim 1, wherein at least one of said plurality of optical filters (220) is a multi-band-pass filter (700a).

7. The optical cross-connect apparatus (200) of claim 1, wherein at least one of said plurality of optical filters (202-n, 212) is a reconfigurable multi-band-pass filter (700b).

8. The optical cross-connect apparatus (200) of claim 1, wherein said optical cross-connect (210) includes a plurality of optical couplers (206).

9. The optical cross-connect apparatus (200) of claim 1, wherein at least one of said plurality of optical couplers (206) is a passive optical coupler.

10. A method for cross connecting a plurality of optical inputs (202-n) and a plurality of optical outputs (204-n), the method comprising:

providing an optical cross-connect (210) between the plurality of optical inputs (202-n) and the plurality of optical outputs (204-n); and

optically filtering at least one optical channel of an optical signal flowing into at least one of said plurality of optical inputs (202-n) or at least one optical channel of an optical signal flowing out of at least one of said plurality of optical outputs (204-n) or both.

11. The method of claim 10, wherein the optical cross-connect (210) is spectrally transparent.

12. The method of claim 10, wherein said optically filtering step includes multi-band-pass filtering at least one optical channel of an optical signal flowing into at least one of said plurality of optical inputs (202-n) or at least one optical channel of an optical signal flowing out of at least one of said plurality of optical outputs (204-n) or both.

13. An optical cross-connect apparatus (200), comprising:
a plurality of optical inputs (202-n);
a plurality of optical outputs (204-n);
an optical cross-connect (210) provided between said plurality of optical inputs (202-n) and said plurality of optical outputs (204-n) such that paths are formed between a subset of said plurality of optical inputs (202-n) and a subset of said plurality of optical outputs (204-n), wherein a path is

defined as a connection between a particular optical input (202-n) and a particular output (204-n); and

at least one optical filter (220) provided outside of said cross-connect (210) such that for at least one path that exists between a particular optical input (202-n) and a particular optical output (204-n), the path's input is filtered or the path's output is filtered or both.

14. The optical cross-connect apparatus (200) of claim 13, wherein said optical cross-connect (210) includes:

optical splitters (206-m) optically coupled to said optical inputs (202-n); and

optical combiners (206-m) optically coupled to said optical outputs (204-n),

wherein said optical splitters (206-m) are optically coupled to said optical combiners (206-m) in a broadcast and combine arrangement.

15. The optical cross-connect apparatus (200) of claim 14, wherein each optical input (202-n) is optically coupled to a respective one of said optical splitters (206-m) and each optical output (204-n) is optically coupled to a respective one of said optical combiners (206-m).

16. The optical cross-connect apparatus (200) of claim 13, wherein there are no optical filters included within said optical cross-connect (210).

17. The optical cross-connect apparatus (200) of claim 13, wherein for each path, the path's input is filtered or the path's output is filtered or both.

18. The optical cross connect apparatus (200) of claim 13, wherein said at least one of said optical filters (220) is a multi-band-pass filter (700a).

19. The optical cross connect apparatus (200) of claim 13, wherein said at least one of said input and output optical filters (220) is a reconfigurable multi-band-pass filter (700b).

20. A fiber ring network (300), comprising:
a first and second outer rings (302) carrying optical signals in a first direction;
a first and second inner rings (304) carrying optical signals in a second direction opposite the first direction; and
an optical cross-connect apparatus (200) as claimed in claim 1 for providing for at least an outer-to-outer connection between the first and second outer rings (302) and an inner-to-inner connection between said first and second inner rings.

21. The fiber ring network (300) of claim 20, wherein there are no optical filters within said optical cross-connect apparatus (200), said network (300) further comprising at least one adjacent ring node (306)

optically placed in a path of one or more of said first and second outer rings (302) and first and second inner rings (304) such that said adjacent ring node performs an optical filtering function.

22. The fiber ring network (300) of claim 21, wherein said adjacent ring node includes a multi-band-pass filter (700a, 700b).

23. A mesh network (400), comprising:
an optical cross-connect apparatus (200) as claimed in claim 1; and
an optical add/drop module (430) optically connected to one of said plurality of optical inputs (402) and to one of said plurality of optical outputs (404).

24. The mesh network (400) of claim 23, wherein the optical add/drop module (430) includes a first and second multi-band-pass filters (432).

25. The mesh network (400) of claim 24, said first and second multi-band-pass filters (432) are optically connected to said one of said plurality of optical inputs (402) and to said one of the plurality of said optical outputs (404), respectively.

26. A method for cross connecting a plurality of optical inputs (202-n) and a plurality of optical outputs (204-n), the method comprising:

localizing a cross-connecting function of an optical cross-connect (210) for cross-connecting the plurality of optical inputs (202-n) and the plurality of optical outputs (204-n); and

external optical filtering with reconfigurable optical filter (220) external to the optical cross-connect (210).

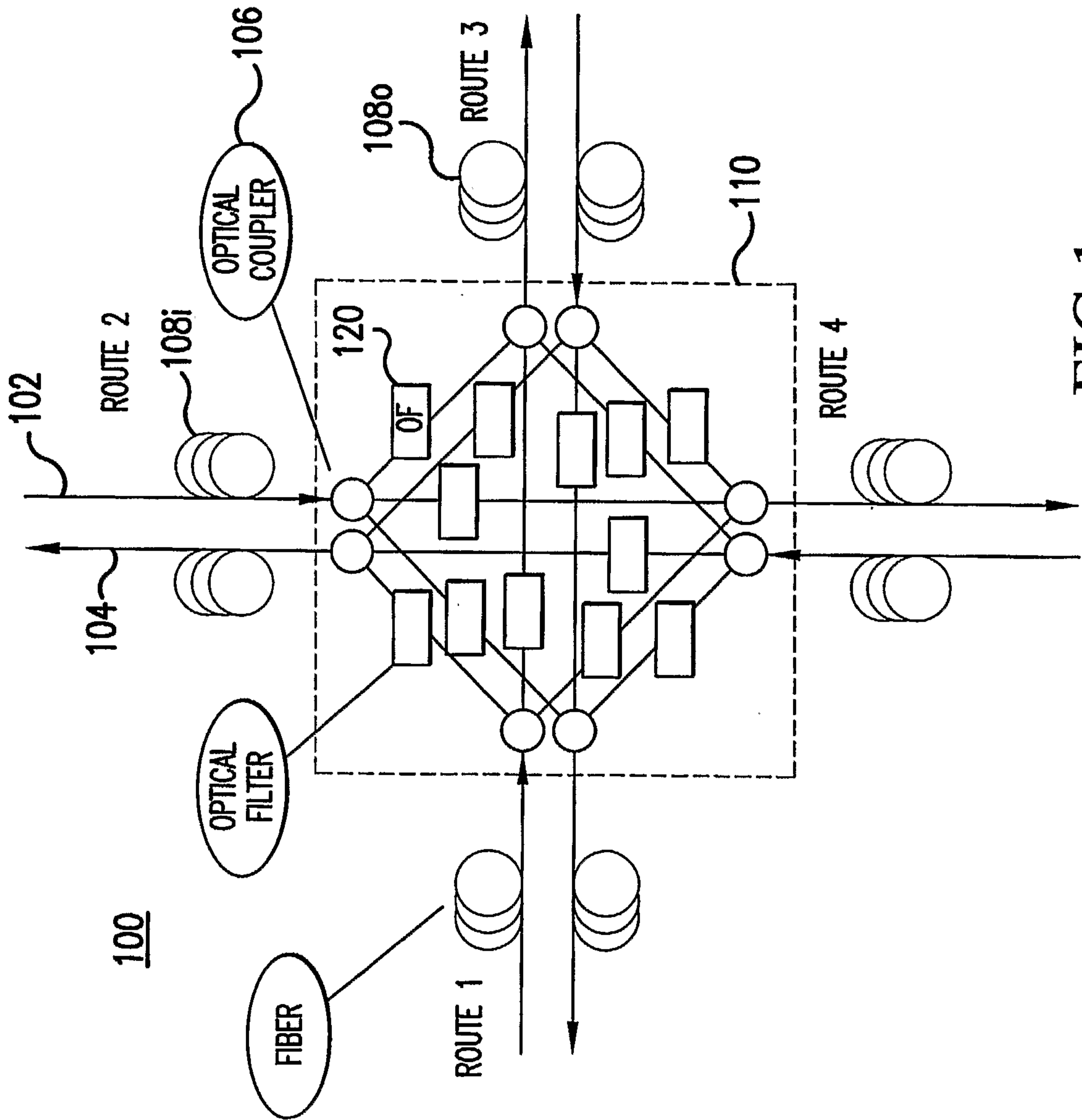

FIG. 1
CONVENTIONAL ART

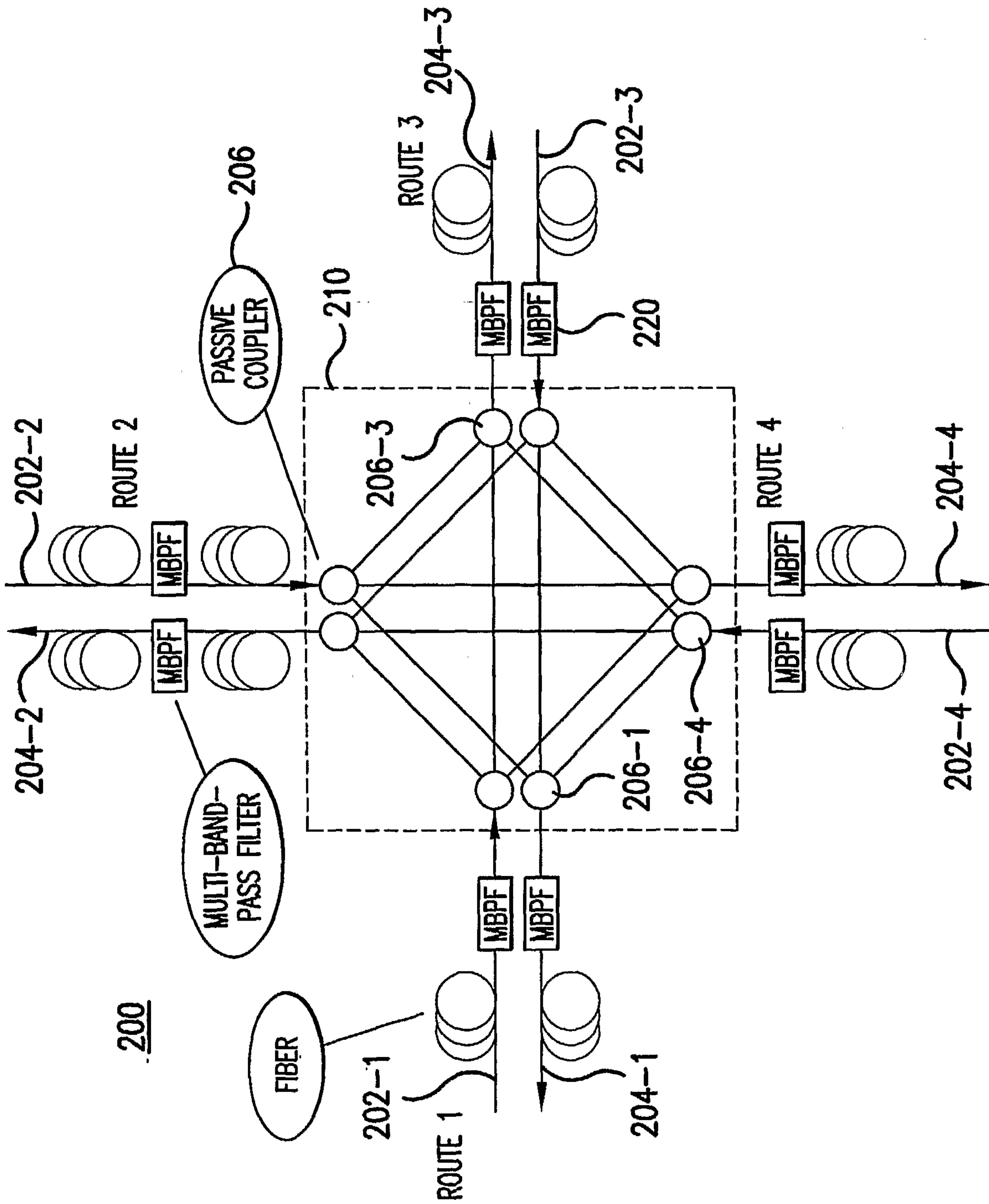

FIG.2

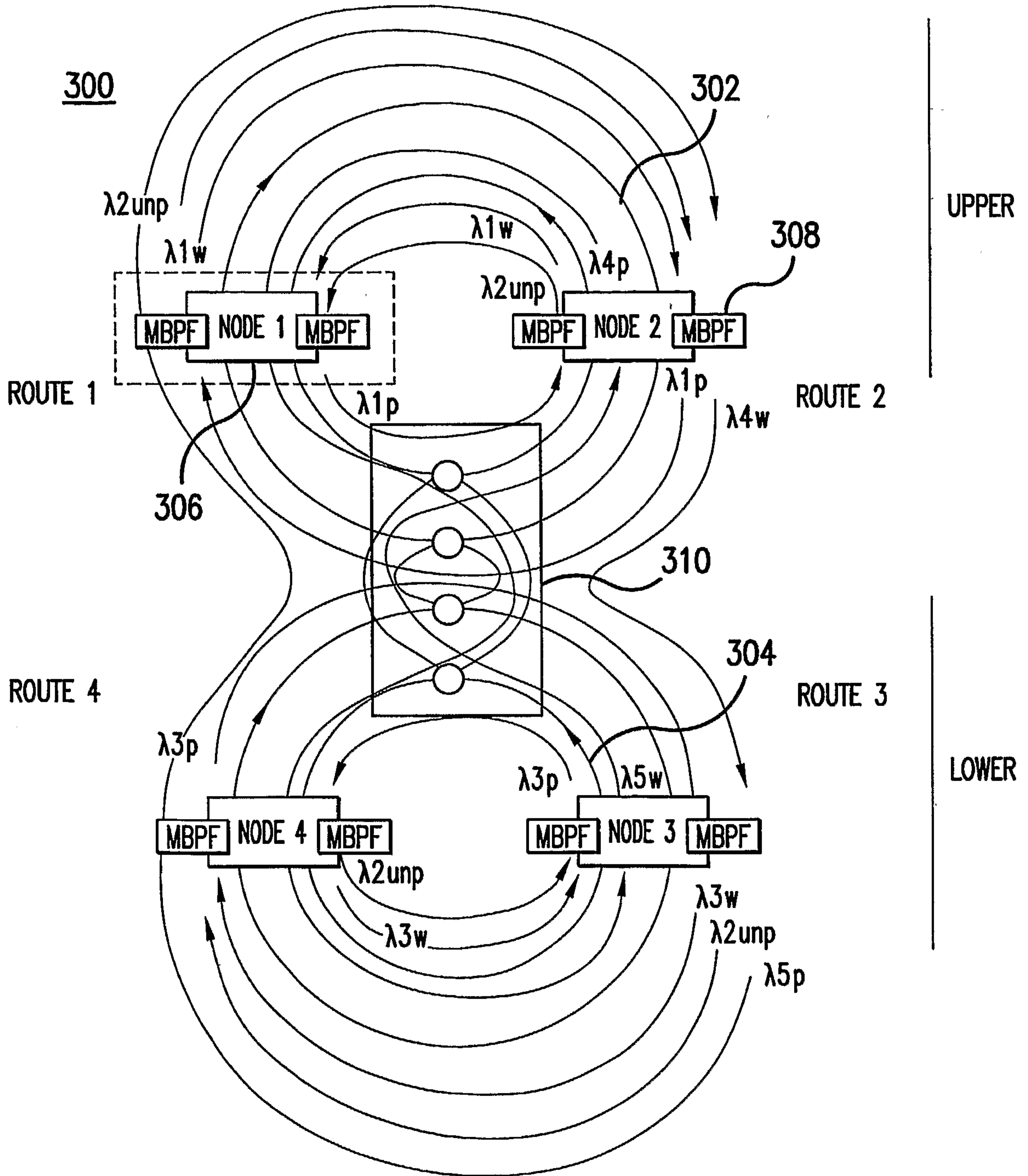

FIG.3

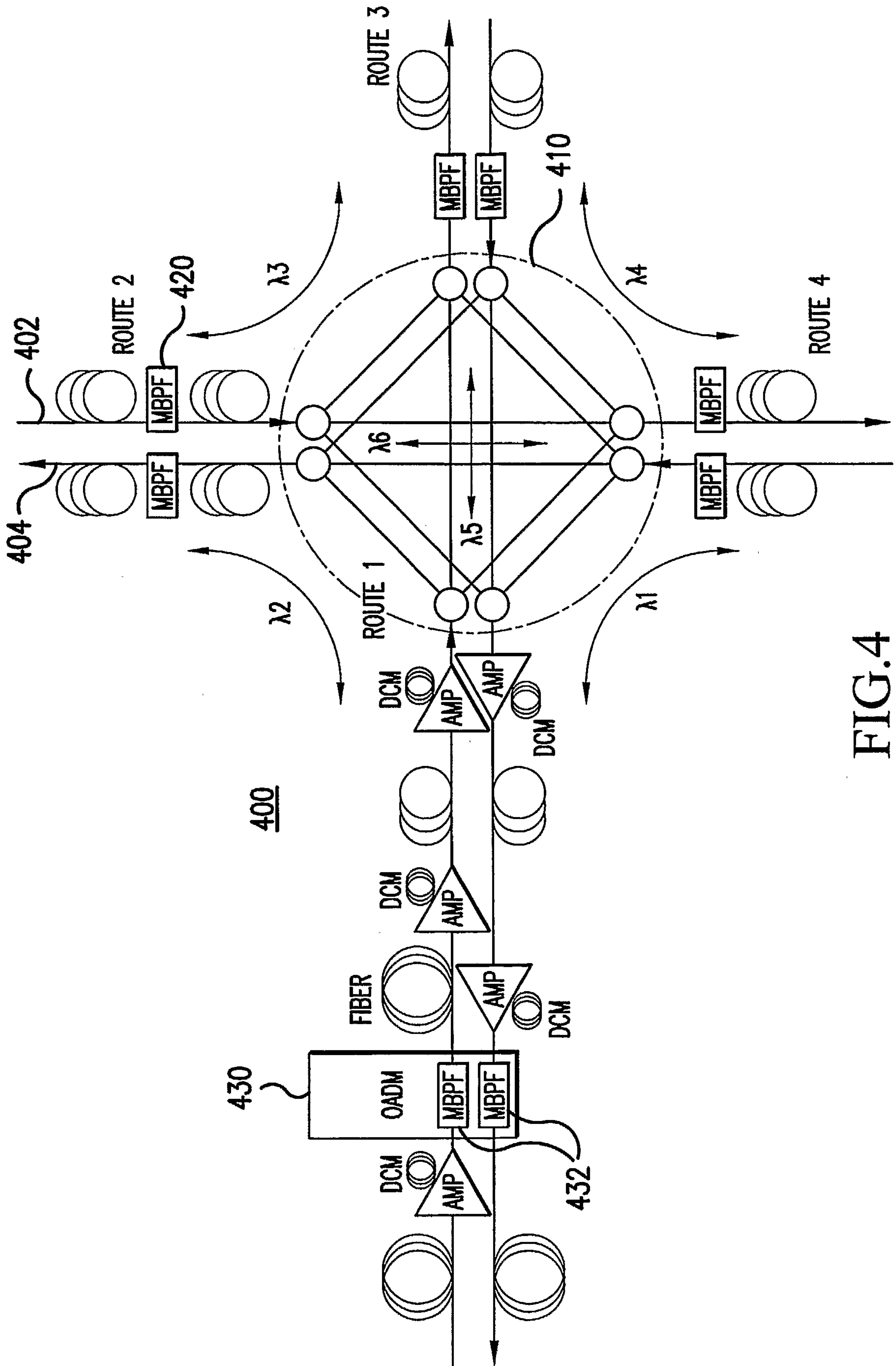

FIG.4

EXAMPLE (MODEL NETWORK)
SHOWS HOW MBPF COUNT DROPS WITH HIGHER SYSTEM CAPACITY

PATH=[1 2
2 3
2 7
3 8
3 4
12 13
7 12
13 18
18 19
18 23
23 24
19 20
17 18];

DEMAND=[1 8 20
2 8 10
2 7 10
2 12 20
2 20 20
17 20 10
13 18 15
12 13 15
12 23 10
18 25 20
13 17 20
13 24 20
7 12 15];

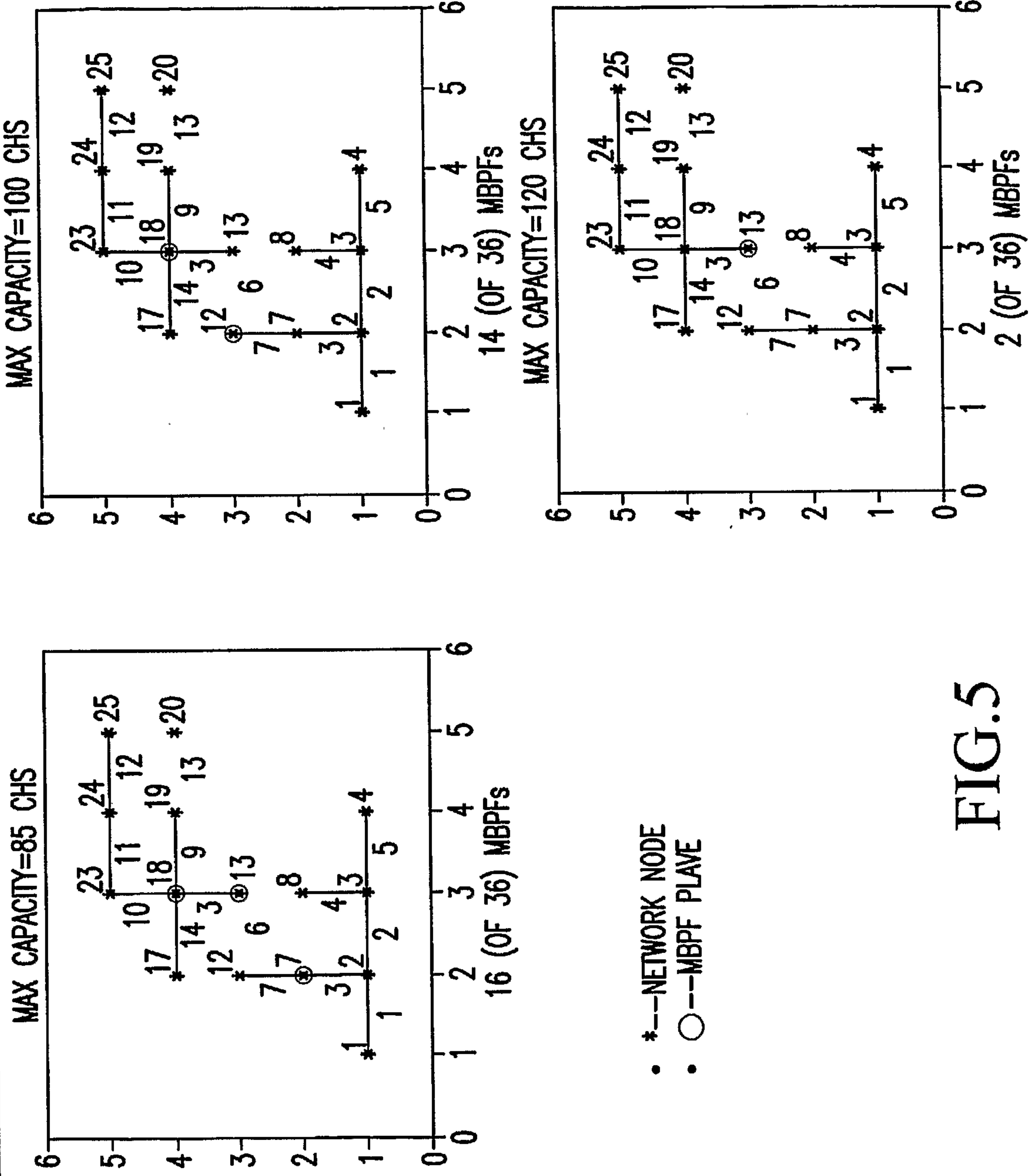
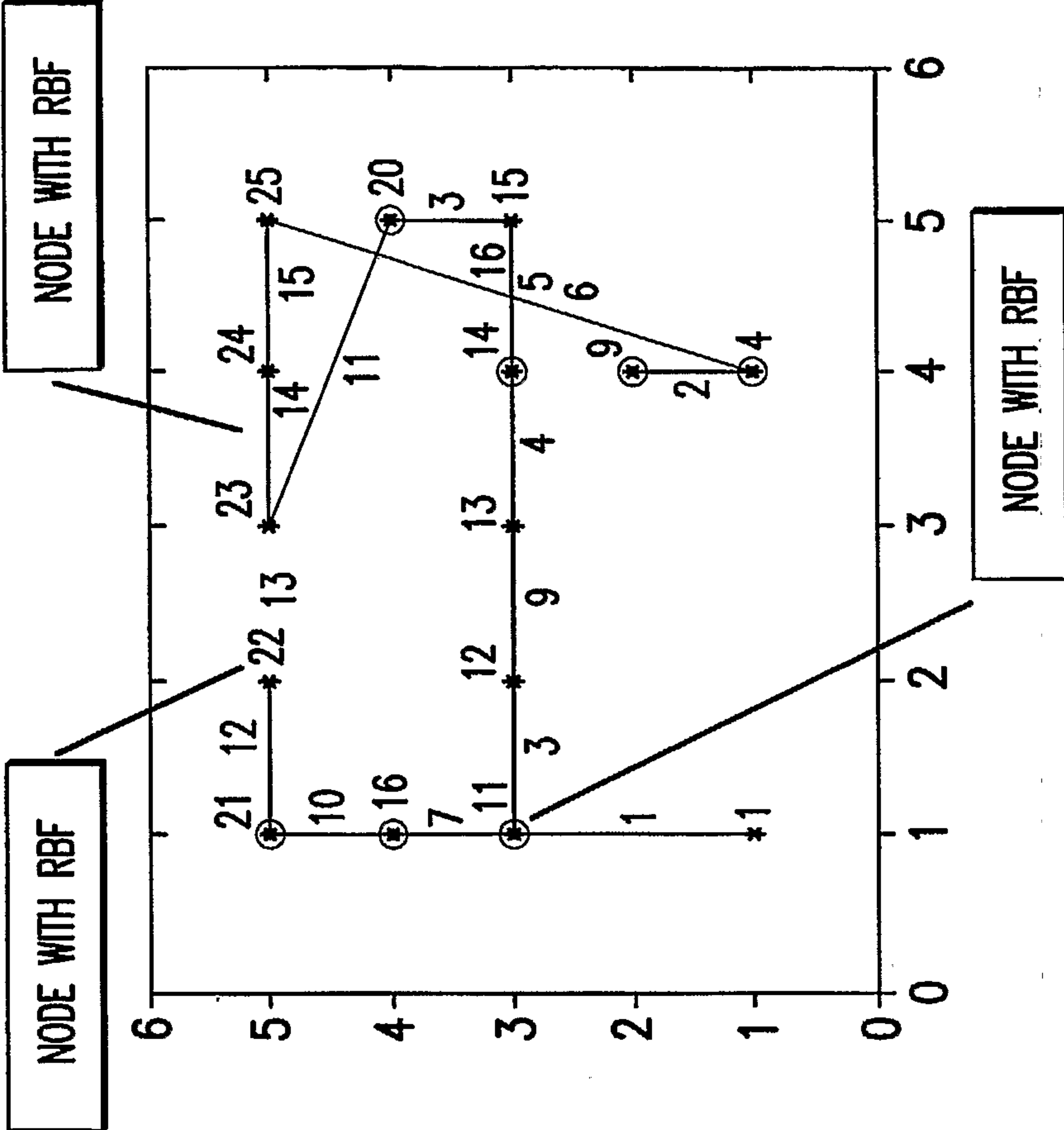

FIG.5

EXAMPLE USING CARRIER SUBNET:
EXT-BAND AMPS, 256 CHS MAX

PATH=	1	4	11	13	14	9	11	15	12	16	20	21	22	23	24	25	4	
DEMAND=	1	11	12	13	14	15	16	21	22	23	20	15	15	9	4	4	23	
	127	49	41	43	45	127	125	58	60	67	69	105	109	6	5	127	49	5



- *---NETWORK NODE
- O---MBPF PLACE
- NOTE: ONLY 18 OUT OF 40 POSSIBLE MBPFs DEPLOYED!

FIG.6

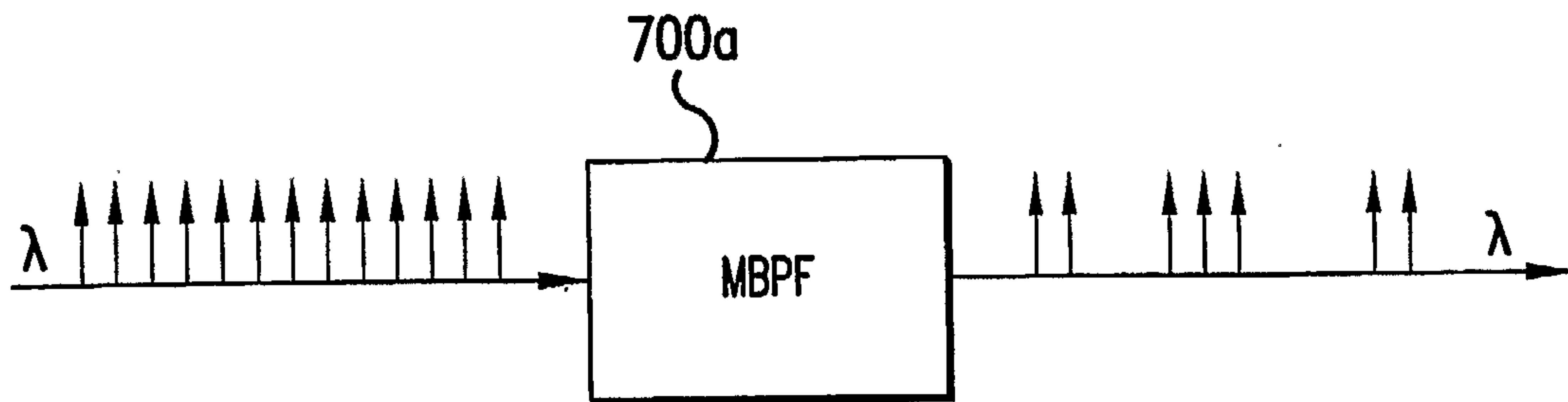

FIG.7a

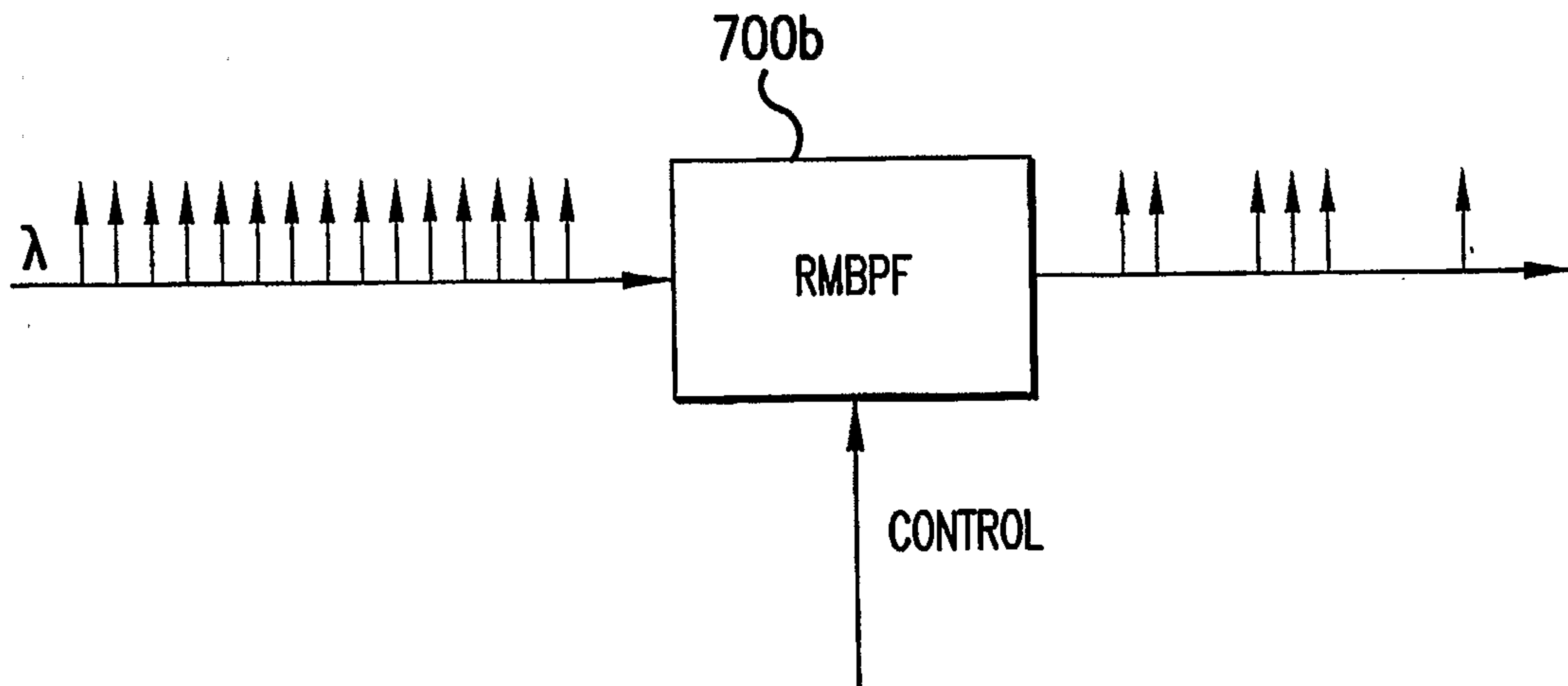

FIG.7b

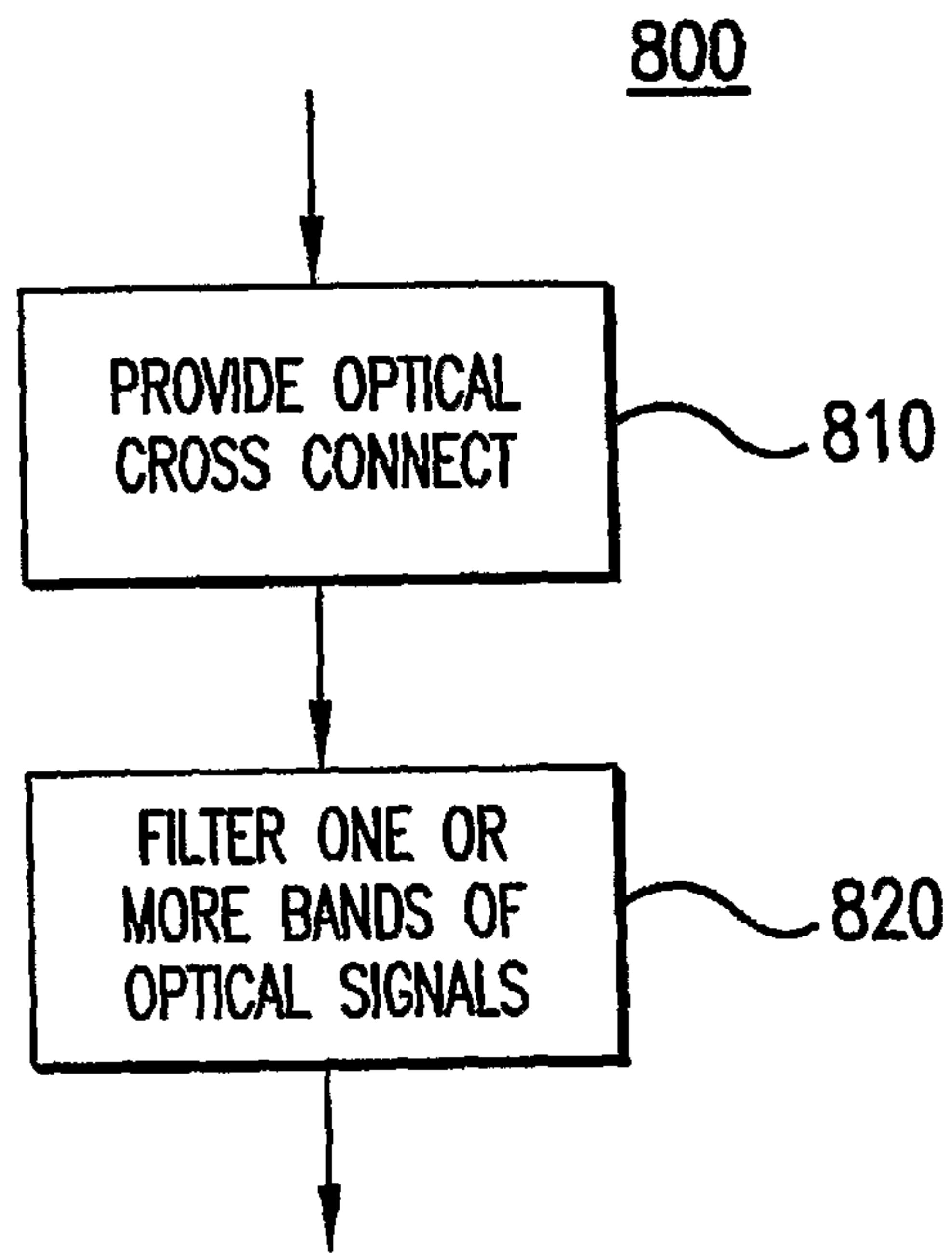

FIG.8

