



- (51) **International Patent Classification:**  

<i>F01B 23/10</i> (2006.01)	<i>F16C 29/02</i> (2006.01)	13/340,538 29 December 2011 (29.12.2011) US
<i>F16J1/08</i> (2006.01)	<i>F02B 63/04</i> (2006.01)	13/340,544 29 December 2011 (29.12.2011) US
<i>F16J 10/04</i> (2006.01)		
- (71) **Applicant:** ETAGEN, INC. [US/US]; 186 Constitution Drive, Menlo Park, California 94025 (US).
- (72) **Inventors:** SVRCEK, Matt; 163 Santiago Avenue, Redwood City, California 94061 (US). LAWLER, John; 45 Lincoln Way, #7, San Francisco, California 94122 (US). MILLER, Shannon; 1821 Hillman Ave, Belmont, California 94002 (US).
- (74) **Agents:** SHVARTS, Alexander et al; 1121 San Antonio Road, Suite B101, Palo Alto, California 94303 (US).
- (81) **Designated States** (*unless otherwise indicated, for every kind of national protection available*): AE, AG, AL, AM,
- (21) **International Application Number:** PCT/US20 12/07 1524
- (22) **International Filing Date:** 21 December 2012 (21.12.2012)
- (25) **Filing Language:** English
- (26) **Publication Language:** English
- (30) **Priority Data:**  

13/340,534	29 December 2011 (29.12.2011)	US
13/340,537	29 December 2011 (29.12.2011)	US

[Continued on nextpage]

(54) **Title:** METHODS AND SYSTEMS FOR MANAGING A CLEARANCE GAP IN A PISTON ENGINE

(57) **Abstract:** A piston engine may include a heat pipe capable of transferring heat away from a portion of the piston engine such as a combustion section. The heat pipe may be included as part of a piston assembly, a cylinder, or both. The heat pipe may be filled with a suitable heat pipe fluid that may undergo a phase change such as, for example, water, ethanol, ammonia, sodium, other fluids or combinations thereof. Boiling and condensing of the fluid within the heat pipe may utilize the latent heat of the fluid during heat transfer. Multiple heat pipes may be used in some instances.

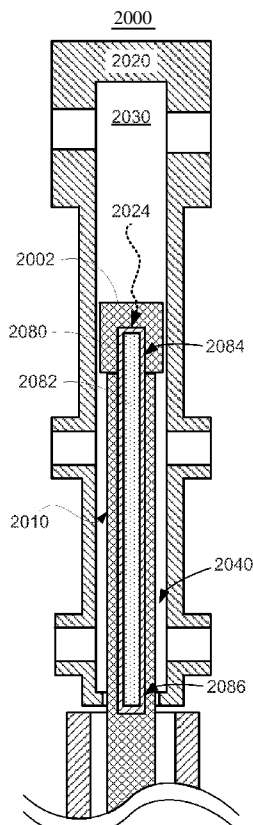

FIG. 20



AO, AT, AU, AZ, BA, BB, BG, BH, BN, BR, BW, BY, BZ, CA, CH, CL, CN, CO, CR, CU, CZ, DE, DK, DM, DO, DZ, EC, EE, EG, ES, FI, GB, GD, GE, GH, GM, GT, HN, HR, HU, ID, IL, IN, IS, JP, KE, KG, KM, KN, KP, KR, KZ, LA, LC, LK, LR, LS, LT, LU, LY, MA, MD, ME, MG, MK, MN, MW, MX, MY, MZ, NA, NG, NI, NO, NZ, OM, PA, PE, PG, PH, PL, PT, QA, RO, RS, RU, RW, SC, SD, SE, SG, SK, SL, SM, ST, SV, SY, TH, TJ, TM, TN, TR, TT, TZ, UA, UG, US, UZ, VC, VN, ZA, ZM, ZW.

**(84) Designated States** (unless otherwise indicated, for every kind of regional protection available): ARIPO (BW, GH, GM, KE, LR, LS, MW, MZ, NA, RW, SD, SL, SZ, TZ,

UG, ZM, ZW), Eurasian (AM, AZ, BY, KG, KZ, RU, TJ, TM), European (AL, AT, BE, BG, CH, CY, CZ, DE, DK, EE, ES, FI, FR, GB, GR, HR, HU, IE, IS, IT, LT, LU, LV, MC, MK, MT, NL, NO, PL, PT, RO, RS, SE, SI, SK, SM, TR), OAPI (BF, BJ, CF, CG, CI, CM, GA, GN, GQ, GW, ML, MR, NE, SN, TD, TG).

**Published:**

- with international search report (Art. 21(3))
- before the expiration of the time limit for amending the claims and to be republished in the event of receipt of amendments (Rule 48.2(h))

5

10

METHODS AND SYSTEMS FOR MANAGING A CLEARANCE GAP IN A PISTON  
ENGINE

15 Background

As an engine's compression ratio is increased, while maintaining a particular bore-to-stroke ratio, the surface to volume ratio at top dead center (TDC) increases, the temperature increases, and the pressure increases. This has three major consequences: 1) heat transfer from the combustion chamber increases, 2) combustion phasing becomes difficult, and 3) friction and mechanical losses increase. Heat transfer increases because the thermal boundary layer becomes a larger fraction of the overall volume as the aspect ratio (i.e., the ratio of the bore diameter to the length of the combustion chamber) at TDC gets smaller. Both combustion phasing and achieving complete combustion present challenges because of the small volume realized at TDC. Increased combustion chamber pressure directly translates to increased forces acting on components of the engine. These large forces may overload both the mechanical linkages within the engine (e.g., piston pin, piston rod, crank shaft) and the pressure-energized rings, thus causing increased friction, wear, and/or failure .

35 A primary challenge associated with linear piston engines is efficiently converting the kinetic energy of a piston to mechanical work and/or electrical energy. The space between the piston and the cylinder wall, referred to herein as a

"clearance gap," is critical in maintaining piston alignment, preventing piston-wall contact and associated friction losses, and controlling gas leakage past the piston (e.g., blow-by) . The clearance gap may be affected by imbalanced forces acting  
5 on the piston, thermally induced expansion or contraction (e.g., solid deformation), changing engine conditions, or other relevant factors. Management of the clearance gap, piston temperature, cylinder temperature, or combinations thereof, may be desired in some applications.

10

#### Summary

In some embodiments, a piston engine may include a piston and cylinder assembly, which may include a fluid bearing in the clearance gap between a bore of a cylinder and a piston  
15 assembly. The piston assembly may be capable of translating axially within the bore, and a piston face may contact a combustion section of the cylinder, facing one end of the cylinder. At least one bearing element may provide a flow of a bearing fluid into the clearance gap between the bore and  
20 the piston assembly to form the fluid bearing. In some embodiments, the bearing element may be a part of the piston assembly, providing a flow of bearing fluid radially outward, and the piston assembly may include fluid passages to direct the bearing fluid. In some embodiments, the bearing element  
25 may be a part of the cylinder, providing a flow of bearing fluid radially inward, and the cylinder may include fluid passages to direct the bearing fluid. A bearing element may include holes, an effusive surface, any other suitable fluid outlet, or any combination thereof to provide the bearing  
30 fluid to the clearance gap.

In some embodiments, a piston engine may include a piston and cylinder assembly including a piston having a self-centering feature, and a cylinder. The piston may be configured to translate axially within a bore of the cylinder.

In some embodiments, the piston may be a part of a piston assembly that translates axially within the bore of the cylinder. The cylinder may include a combustion section capable of containing combustion products. Blow-by gas from the combustion section may flow axially away from the combustion section, past a piston face, through a clearance gap between the piston and the cylinder. The self-centering feature may provide a self-centering force on the piston using the flow of blow-by gas. The self-centering feature may be a step, one or more slotted pockets, a tapered portion, any other suitable feature, or any combination thereof.

In some embodiments, a piston engine may include a piston assembly having one or more heat pipes. The piston assembly may be configured to translate axially within a bore of the cylinder. The cylinder may include a combustion section capable of containing combustion products, and accordingly a piston face of the piston assembly may experience elevated temperatures. In some embodiments, the heat pipe may be in thermal contact with the piston face, and may be capable of transferring heat from the piston face to a heat receptacle. A first portion of the heat pipe may receive heat from the piston face, and a second portion of the heat pipe may transfer the heat to a heat receptacle. The heat pipe may include a fluid such as, for example, water, ethanol, ammonia, or sodium, which may undergo a vapor-liquid phase transition.

In some embodiments, a piston engine may include a cylinder liner configured to be positioned coaxially within a cylinder of a piston engine. The cylinder liner may include an inner face that is capable of forming a clearance gap with a piston assembly that is capable of translating axially within the cylinder liner. The cylinder liner may also include an outer face that interfaces with the cylinder of the piston engine. The interface between the outer face and the cylinder may include a fluid passage that may act as a conduit

for a pressure controlled fluid. The cylinder liner may be configured to radially contract or expand based at least in part on the pressure controlled fluid, and thus the clearance gap may be adjusted.

5 In some embodiments, a piston engine may include one or more fluid passages configured to provide localized, selective, fast-response, or otherwise controlled heating or cooling to a cylinder. A flow rate, temperature, pressure, or combination thereof of a fluid supplied to the fluid passages  
10 may be adjusted by a control system to control a temperature of the piston engine. In some embodiments, a cylinder may include one or more localized heating sources such as, for example, one or more electric heaters, which may be controlled by a control system to provide localized heating.

15 In some embodiments, a clearance gap between a coaxial piston assembly and a cylinder of a piston engine may be controlled. At least one indicator such as for example, temperature, pressure, a work interaction, and/or other suitable indicators of the clearance gap may be detected using  
20 one or more sensors. A control response may be determined by processing equipment based at least in part on the indicator. The processing equipment may use a control interface to provide a control signal to at least one auxiliary system of the piston engine based at least in part on the control  
25 response. At least one auxiliary system may adjust the clearance gap based at least in part on the control signal.

#### Brief Description of the Figures

The above and other features of the present disclosure,  
30 its nature and various advantages will be more apparent upon consideration of the following detailed description, taken in conjunction with the accompanying drawings in which:

**FIG. 1** shows a cross-section view of an illustrative piston engine with a piston assembly, a gas spring, and an

integrated linear electromagnetic machine (LEM) included as part of the cylinder, in accordance with some embodiments of the present disclosure;

**FIG. 2** shows a cross-section view of an illustrative piston engine with a piston assembly, a gas spring, and an integrated linear electromagnetic machine (LEM), in accordance with some embodiments of the present disclosure;

**FIG. 3** shows a cross-section view of an illustrative piston engine with a piston assembly having two pistons, a separate gas spring, and an integrated LEM, in accordance with some embodiments of the present disclosure;

**FIG. 4** shows a cross-section view of an illustrative piston engine with two piston assemblies, separated gas springs, and two integrated LEMs, in accordance with some embodiments of the present disclosure;

**FIG. 5** shows a perspective view of a portion of an illustrative piston assembly with a self-centering feature, in accordance with some embodiments of the present disclosure;

**FIG. 6** shows a cross-section view of an illustrative piston assembly and cylinder, with blow-by from a combustion section, in accordance with some embodiments of the present disclosure;

**FIG. 7** shows a cross-section view of the illustrative piston assembly and cylinder of **FIG. 6**, in which the piston assembly is out of center, in accordance with some embodiments of the present disclosure;

**FIG. 8** shows a cross-section view of the illustrative piston assembly and cylinder of **FIG. 6**, in which the piston assembly is centered, in accordance with some embodiments of the present disclosure;

**FIG. 9** shows a cross-section view of a portion of an illustrative piston engine with a piston assembly having a feature that may aid in centering the piston assembly, in accordance with some embodiments of the present disclosure;

**FIG. 10** shows a cross-section view of a portion of an illustrative piston engine with a piston assembly having a pocketed self-centering feature, in accordance with some embodiments of the present disclosure;

5 **FIG. 11** shows a cross-section view of a portion of an illustrative piston engine with a piston assembly having a stepped self-centering feature, in accordance with some embodiments of the present disclosure;

10 **FIG. 12** shows a cross-section view of a portion of an illustrative piston engine with a piston assembly having a tapered self-centering feature, in accordance with some embodiments of the present disclosure;

15 **FIG. 13** shows a perspective view of a portion of an illustrative piston assembly with a bearing element having holes, in accordance with some embodiments of the present disclosure;

**FIG. 14** shows a perspective view of a portion of an illustrative piston assembly with a porous bearing element, in accordance with some embodiments of the present disclosure;

20 **FIG. 15** shows a cross-section view of an illustrative piston assembly, with a fluid bearing fed through the piston assembly, in accordance with some embodiments of the present disclosure;

25 **FIG. 16** shows a cross-section view of an illustrative piston assembly and cylinder, with a fluid bearing fed through the piston assembly, in accordance with some embodiments of the present disclosure;

30 **FIG. 17** shows a cross-section view of an illustrative piston assembly and cylinder, with a fluid bearing fed through the cylinder, in accordance with some embodiments of the present disclosure;

**FIG. 18** shows a cross-section view of an illustrative arrangement of a piston assembly and cylinder, having fluid

bearings and a translator having a fluid passage, in accordance with some embodiments of the present disclosure;

**FIG. 19** shows a cross-section view of an illustrative arrangement of a piston assembly and cylinder, having fluid bearings and a check valve, in accordance with some  
5 embodiments of the present disclosure;

**FIG. 20** shows a cross-section view of an illustrative piston assembly and cylinder, with a heat pipe included as part of the piston assembly, in accordance with some  
10 embodiments of the present disclosure;

**FIG. 21** shows a cross-section view of an illustrative piston assembly with a heat pipe formed by an interior void, in accordance with some embodiments of the present disclosure;

**FIG. 22** shows a cross-section view of an illustrative piston engine having a piston assembly, and a cylinder having coolant passages and heat pipes, in accordance with some  
15 embodiments of the present disclosure;

**FIG. 23** shows a cross-section view of an illustrative piston assembly and cylinder, with a deformable cylinder liner, in accordance with some embodiments of the present  
20 disclosure;

**FIG. 24** shows a cross-section view of the illustrative piston assembly and cylinder of **FIG. 23**, with the deformable cylinder liner undergoing deformation, in accordance with some  
25 embodiments of the present disclosure;

**FIG. 25** shows a cross-section view of an illustrative piston assembly and cylinder, with a sectioned deformable cylinder liner, in accordance with some embodiments of the present disclosure;

**FIG. 26** shows a cross-section view of an illustrative piston engine, with a deformable cylinder liner, in accordance with some embodiments of the present disclosure;

**FIG. 27** shows a cross-section view of a portion of an illustrative piston engine, with localized coolant passages, in accordance with some embodiments of the present disclosure;

**FIG. 28** shows a cross-section view of a portion of an illustrative piston engine, with localized coolant passages, in accordance with some embodiments of the present disclosure;

**FIG. 29** shows a cross-section view of a portion of an illustrative piston engine, with localized heat sources including electric heaters, in accordance with some embodiments of the present disclosure;

**FIG. 30** shows a cross-section view of a portion of an illustrative piston engine, including fluid passages, which may be used for heating, cooling, or both, in accordance with some embodiments of the present disclosure;

**FIG. 31** shows a perspective view of a portion of an illustrative piston assembly having bearing elements and a self-centering feature, in accordance with some embodiments of the present disclosure;

**FIG. 32** shows a cross-section view of an illustrative piston engine with a piston assembly having a bearing element, a heat pipe, and a self-centering feature, and a cylinder having a deformable cylinder liner and coolant passages, in accordance with some embodiments of the present disclosure;

**FIG. 33** is a block diagram of an illustrative control arrangement for a piston engine, in accordance with some embodiments of the present disclosure;

**FIG. 34** is a flow diagram of illustrative steps for adjusting a clearance gap of a piston engine, in accordance with some embodiments of the present disclosure; and

**FIG. 35** is a flow diagram of illustrative steps for adjusting one or more properties of a piston engine, in accordance with some embodiments of the present disclosure.

Detailed Description of the Figures

The present disclosure is directed towards managing the clearance gap and/or other properties of a piston engine. While discussed in the context of free piston engines, the techniques and arrangements disclosed herein can be applied to non-free piston engines, or other suitable mechanical systems. Herein, the term "piston engine" shall refer to both free and non-free piston engines.

A piston engine, operating using any suitable thermodynamic cycle, may include a piston and cylinder assembly to realize displacement work. The piston and cylinder may be separated by a relatively small clearance gap, and the piston translates axially within a bore of the cylinder. In some embodiments, the piston may be included as part of a "piston assembly," which may also include one or more piston seals (e.g., piston rings), bearing elements, frames, piston rods, translators and/or other components, which may be capable of moving in concert as a substantially rigid assembly, at least partially within the bore. The clearance gap may be constant or varied along the radial perimeter of the piston assembly, or component thereof (e.g., the clearance may be described by a thickness value, a profile or field of values, and/or a symmetry metric). The cylinder may include a combustion section, into which oxidizer (e.g., air, vitiated air, oxygen) and fuel (e.g., a gaseous or liquid hydrocarbon fuel) may be supplied separately, or as a pre-mixed mixture, for combustion. Expansion of the hot combustion products causes displacement of the piston. Work may be extracted from the piston's motion using a mechanical linkage (e.g., using a piston rod and crankshaft assembly), an electromagnetic interaction (e.g., using a linear electromagnetic machine (LEM) having a translator and stator as described in the present disclosure), a gas linkage (e.g., using two pistons interacting via an intermediate gas volume), any other suitable work extraction technique, or any

combination thereof. Compression of the air and/or fuel by the piston-cylinder assembly may also be achieved using the motion of the piston. In some embodiments, compression work may be provided by a gas driver, a LEM, or both.

5       **FIGS. 1-4** show illustrative piston engines that may benefit from the teachings of the present disclosure. It will be understood that the teachings of the present disclosure may be applied to any other suitable piston engines in addition to the ones illustrated in the figures and described herein. It  
10 will also be understood that although not illustrated in **FIGS. 1-4**, a piston engine may include one or more subsystems such as, for example, cooling subsystems, air delivery systems, fuel delivery systems, ignition subsystems, exhaust systems, electronic control systems, and/or other suitable subsystems,  
15 and that the phrase "piston engine" may refer to a suitable collection of components and subsystems.

**FIG. 1** shows a cross-section view of an illustrative piston engine **100** with a piston assembly **110**, gas spring **148**, and an integrated linear electromagnetic machine (LEM) **160**, in  
20 accordance with some embodiments of the present disclosure. Piston engine **100** includes a cylinder **140** having a bore **134** and a combustion section **130**, as well as a piston assembly **110**. In the illustrated embodiment, piston assembly **110** includes two piston faces **112**, piston seals **114** and **115**, and  
25 translator **116**. Although not shown in **FIG. 1**, piston assembly **110** may include bearing elements, a piston rod, any other suitable components, or any combination thereof. In the illustrated embodiment, piston assembly **110** is located completely within bore **134** of cylinder **140**, and is configured  
30 to translate substantially along axis **150**. Cylinder **140**, as shown in **FIG. 1**, includes exhaust/injector ports **170** (for removal of exhaust and/or injection of reactants), intake ports **180** (for intake of air and/or air/fuel mixtures), and driver gas ports **190** (for supply and/or removal of driver

gas) . Piston engine 100 may operate using a two-stroke cycle, a four-stroke cycle, any other suitable cycle, or any combination thereof. Impact plate 108 may be included in some embodiments to aid in impact resistance, for example, during  
5 combustion. Valves and/or other fluid components may, but need not, be used with any or all of ports 170, 180, and 190 to control inflows and outflows of fluids to and from piston engine 100.

Cylinder 140 may include portion 132 in which combustion, gas expansion, and exhaust may occur, portion 168 in which  
10 electromagnetic work interactions may occur, and portion 178 in which gas driving and gas springing may occur. Portions 132, 168, and 178 may depend on the configuration of cylinder 140, as well as the position of piston assembly 110 within  
15 bore 134 of cylinder 140. Stator 162, used to extract electromagnetic work from motion of translator 116, may be included as part of cylinder 140, as shown in FIG. 1.

During an expansion stroke of piston assembly 110 within cylinder 140, due to combustion of an oxidizer and fuel in  
20 combustion section 130, translator 116 may translate through stator 162. The motion of translator 116 relative to stator 162 may generate an electrical current, and corresponding electrical work. LEM 160 may include a permanent magnet machine, an induction machine, a switched reluctance machine,  
25 any other suitable electromagnetic machine, or any combination thereof. For example, translator 116 may include a permanent magnet, and stator 162 may include a wire coil which may conduct an induction current generated by the motion of translator 116.

30 **FIG. 2** shows a cross-section view of an illustrative piston engine 200 with a piston assembly 210, gas spring 248, and LEM 260, in accordance with some embodiments of the present disclosure. Piston engine 200 includes a cylinder 240 having a bore 234, piston assembly 210, and a combustion

section 230. In the illustrated embodiment, piston assembly 210 includes piston faces 212, piston seal 214 (e.g., piston rings, sealing surfaces), translator 216, and piston rod 218. Although not shown in FIG. 2, piston assembly 210 may include 5 bearing elements, any other suitable components, or any combination thereof. In the illustrated embodiment, piston assembly 210 is located partially within bore 234 of cylinder 240, and is configured to translate substantially along axis 250. Cylinder 240, as shown in FIG. 2, includes gas seal 242 10 (to reduce or prevent gas leakage while allowing relative piston motion), exhaust/injector ports 270 (for removal of exhaust and/or injection of reactants), intake ports 280 (for intake of air and/or air/fuel mixtures), and driver gas ports 290 (for supply and/or removal of driver gas). Piston engine 15 200 may operate using a two-stroke cycle, a four-stroke cycle, any other suitable cycle, or any combination thereof. Impact plate 208 may be included in some embodiments.

Cylinder 240 may include portion 232 in which combustion, gas expansion, and exhaust may occur, and portion 278 in which 20 gas driving and gas springing may occur. Portion 268 may be included separate from cylinder 240, and may include LEM 260 for which electromagnetic work interactions may occur. Portions 232, 268, and 278 may depend on the configuration of cylinder 240, as well as the position of piston assembly 210 25 within bore 234 of cylinder 240. Stator 262, used to extract electromagnetic work from motion of translator 216, may be, but need not be, separate from cylinder 240, as shown in FIG. 2.

FIG. 3 shows a cross-section view of an illustrative 30 piston engine 300 with a piston assembly 310 having two pistons 311 and 313, a separate gas spring 348, and LEM 360, in accordance with some embodiments of the present disclosure. Piston engine 300 includes cylinders 340 and 341 having bores 334 and 335, respectively, piston assembly 310, and a

combustion section 330. In the illustrated embodiment, piston assembly 310 includes piston faces 312, translator 316, piston seals 314 and 315, and piston rod 318. Although not shown in FIG. 3, piston assembly 310 may include bearing elements, any other suitable components, or any combination thereof. In the illustrated embodiment, piston assembly 310 is located partially within bore 334 of cylinder 340, and partially within bore 335 of cylinder 341, and is configured to translate substantially along axis 350. Cylinder 340, as shown in FIG. 3, includes gas seal 342 (to reduce or prevent gas leakage while allowing relative piston motion), exhaust/injector ports 370 (for removal of exhaust and/or injection of reactants), intake ports 380 (for intake of air and/or air/fuel mixtures), and gas ports 395 (for removal of blow-by, or supply of air). Cylinder 341, as shown in FIG. 3, includes gas seal 343 (to reduce or prevent gas leakage while allowing relative piston motion), driver gas ports 390 (for supply and/or removal of driver gas). Piston engine 300 may operate using a two-stroke cycle, a four-stroke cycle, any other suitable cycle, or any combination thereof. Impact plate 308 may be included in some embodiments.

Cylinder 340 may include portion 332 in which combustion, gas expansion, and exhaust may occur. Cylinder 341 may include portion 378 in which gas driving and gas springing may occur. Portion 368 may be included between cylinders 340 and 341, and may include a LEM for which electromagnetic work interactions may occur. Portions 332, 368, and 378 may depend on the configuration of cylinders 340 and 341, as well as the position of piston assembly 310 within bores 334 and 335 of respective cylinders 340 and 341. Stator 362, used to extract electromagnetic work from motion of translator 316, may be, but need not be, separate from cylinders 340 and 341, as shown in FIG. 3.

**FIG. 4** shows a cross-section view of an illustrative piston engine **400** with two piston assemblies **410** and **411**, separated gas springs **448** and **449**, and two LEMs **460** and **461**, in accordance with some embodiments of the present disclosure.

5 Piston engine **400**, as shown, is substantially equivalent to two piston engines **300**, symmetric about exhaust/injector ports **370**, having a single combustion chamber. It will be understood that other two-piston arrangements may be achieved in accordance with the present disclosure, which may be but

10 need not be symmetric, and that piston engine **400** is an illustrative example.

Further details regarding piston engines such as piston engine **100**, **200**, **300**, and **400**, and their operation and characteristics, are included in Simpson et al. U.S. patent

15 application No. 12/953,270, Simpson et al. U.S. patent application No. 12/953,277, Simpson et al. U.S. patent application No. 13/102,916, and Roelle et al. U.S. patent application No. 13/028,053, all of which are hereby incorporated by reference herein their entireties.

20

[Self-centering Piston]

In some embodiments, a piston may include one or more features which provide self-centering relative to a cylinder of a piston engine.

25 **FIG. 5** shows a perspective view of a portion of an illustrative piston assembly **500** with a self-centering feature **506**, in accordance with some embodiments of the present disclosure. Piston assembly **500** may include piston face **502**, element **504**, self-centering feature **506**, any other suitable

30 components (not shown), or any combination thereof. In some embodiments, self-centering feature **506** may be a part of element **504**. For example, element **504** may be a bearing element (e.g., an aerostatic bearing), and self-centering feature **506** may be a machined step or other suitable feature

in the bearing element. In some embodiments, self-centering feature **506** may be a part of piston face **502**. For example, self-centering feature **506** may be a step, one or more slotted pockets, a tapered portion, or other feature included in piston assembly **500**. In some embodiments, a piston assembly may include one or more features, components, or both, that aid in centering the piston assembly. For example, a piston assembly may include a self-centering feature and a feature that may aid in equalizing the pressure on one or more lateral surfaces of a piston assembly, which may aid in centering of the piston. Although not shown in **FIG. 5**, piston assembly **500** may optionally include a piston rod, a translator, a piston ring, a fluid bearing, any other suitable components, or any combination thereof.

**FIG. 6** shows a cross-section view of an illustrative arrangement **600** of a piston assembly **610** and a cylinder **620**, with blow-by (shown by arrows **640**) from a combustion section **630**, in accordance with some embodiments of the present disclosure. In some embodiments, piston face **602** may contact combustion section **630** (shown illustratively in **FIG. 6**), a gas driver section (not shown in **FIG. 6**), any other suitable section of a piston engine cylinder (not shown), or any combination thereof. Blow-by may flow from combustion section **630** around the piston face **602** and axially along the piston assembly **610**. In some embodiments, interaction of the blow-by and self-centering feature **616** may act to center piston assembly **610**. For example, a pressure distribution may be generated in the clearance gap between piston assembly **610** and cylinder **620** that acts to center piston assembly **610**. Blow-by may be supplied to a clearance gap from a combustion section, gas driver section, or other suitable section, operating at any suitable pressure (e.g., operating at a pressure of 20-800 bar, or other suitable pressure).

**FIG. 7** shows a cross-section view of illustrative piston assembly **610** and cylinder **620**, in which piston assembly **610** is out of center, in accordance with some embodiments of the present disclosure. Center axis **750** of cylinder **620**

5 illustrates the geometric center axis of the bore of cylinder **620**. When piston assembly **610** is off-centered in cylinder **620**, as shown in **FIG. 7**, the pressure field  $P^1(R, \Theta, Z)$ , in cylindrical coordinates relative to the piston assembly, along the lateral sides (i.e., at radius  $R$  which may vary with  $\Theta$  and  $z$ ) of piston assembly **610** may be circumferentially (i.e., in the  $\Theta$  direction) non-uniform at a given axial position  $z$ .

**FIG. 8** shows a cross-section view of illustrative piston assembly **610** and cylinder **620**, in which piston assembly **610** is centered about center axis **750**, in accordance with some 15 embodiments of the present disclosure. When piston assembly **610** is centered in cylinder **620**, as shown in **FIG. 8**, the pressure field  $P_2(R, \Theta, Z)$  of piston assembly **610** may be substantially circumferentially uniform at a given axial position  $z$ . In some embodiments, the pressure field of the 20 centered piston may be non-uniform, but when integrated over the lateral surface of the piston, give a substantially zero resultant force. For example, a piston assembly having slotted pockets may have a non-uniform circumferential pressure field due to the pockets, but may provide a resultant 25 force of zero.

**FIG. 9** shows a cross-section view of a portion of an illustrative piston engine **900** with a piston assembly **910** having a feature **912** that may aid in centering piston assembly **910**, in accordance with some embodiments of the present 30 disclosure. In some embodiments, a feature such as feature **912** may be included along with a self-centering feature (e.g., any of the self-centering features of **FIGS. 10-12**) in a piston assembly. Feature **912**, as illustrated in **FIG. 9**, may include

one or more groove extending around the full circumference of piston assembly **910**, which may aid in equalizing the pressure field in clearance gap **950** of **FIG. 9**. Feature **912** may also act as a straight-through labyrinth seal to reduce the axial flow rate in clearance gap **950**. Although shown illustratively as grooves in **FIG. 9**, any suitable feature or combination of features thereof may be used to aid in centering, in accordance with the present disclosure.

**FIG. 10** shows a cross-section view of a portion of an illustrative piston engine **1000** with a piston assembly **1010** having a pocketed self-centering feature **1012**, with one or more slots **1014**, in accordance with some embodiments of the present disclosure. Self-centering feature **1012** may include one or more pockets each extending partially around the circumference of piston assembly **1010**. Slots **1014** may include one or more slots (e.g., corresponding to the one or more pockets) that may act as a guide for blow-by to flow into the pockets. Although shown as being located on a lateral surface of piston assembly **1010**, in some embodiments, slots may be included in the interior of a piston assembly, and may be fed from any suitable source. For example, self-centering feature **1012** may include three slotted pockets, each centered  $120^\circ$  apart on the circumference and each extending less than  $120^\circ$  along the circumference, and three corresponding slots **1014** that may allow fluid from a relatively high pressure region **1060** to flow into the pockets. Any suitable arrangement of segmented pockets, including any suitable number of pockets, may be used in accordance with the present disclosure.

**FIG. 11** shows a cross-section view of a portion of an illustrative piston engine **1100** with a piston assembly **1110** having a stepped self-centering feature **1112**, in accordance with some embodiments of the present disclosure. Self-centering feature **1112** may include a step extending around the full circumference of piston assembly **1110**. The step may

include any suitable absolute and/or relative dimensions. In an illustrative example, the clearance gap in the step (i.e., relatively nearer to the piston face **1102**) may be on the order of twice the clearance gap at the larger diameter region of the piston assembly. In some embodiments, a piston assembly may include a segmented step, similar to the slotted pocket arrangement of **FIG. 10** but in which the pockets extend through to the piston face **1102**, and accordingly slots need not be included.

**FIG. 12** shows a cross-section view of a portion of an illustrative piston engine **1200** with a piston assembly **1210** having a tapered self-centering feature **1212**, in accordance with some embodiments of the present disclosure. Self-centering feature **1212** may include a tapered portion extending around the full circumference of piston assembly **1210**, in which the diameter at piston face **1202** is relatively contracted. The taper may include any suitable absolute and/or relative dimensions. In an illustrative example, the clearance gap at the small diameter of the taper (i.e., relatively nearer to the piston face **1202**) may be on the order of twice the clearance gap at the larger diameter region of the piston assembly. In some embodiments, a piston assembly may include more than one tapered sections around the circumference, similar to the slotted pocket arrangement of **FIG. 10**, in which the taper extends through to the piston face **1202**.

In some embodiments, any or all of self-centering features **1012**, **1112**, and **1212**, feature **912**, and other suitable self-centering features or other features may be combined. For example, a piston assembly may include a taper, a step, and a series of grooves (e.g., a labyrinth) to provide centering. Self-centering features may be used near a piston face in contact with a combustion section, gas driver section, gas spring section, any other suitable piston face that allows

blow-by gas to flow past the piston face, or any combination thereof. For example, referencing piston engine **300** of **FIG. 3**, self-centering features may be included near any of piston faces **312**.

5

[Non-Contact Bearings]

In some embodiments, a non-contact bearing may be used between a piston and a corresponding cylinder. A non-contact bearing may include, for example, an aerostatic bearing, a hydrostatic bearing, or other suitable non-contact bearing that may be moving or stationary. Non-contact bearings may include a thin film of fluid that separates the piston and cylinder wall, reducing friction and associated work losses. In some embodiments, the use of aerostatic bearings may allow for oil-less operation of the piston and cylinder assembly of a piston engine, and accordingly the piston engine need not require an auxiliary oil system, which may simplify some aspects of the engine architecture. In some embodiments, non-contact bearings may include oil as the bearing fluid. The bearing fluid may include, for example, air, nitrogen, exhaust, oil, liquid water, water vapor, liquid CO<sub>2</sub>, gaseous CO<sub>2</sub>, hydraulic fluid, any other suitable fluid, or any combination thereof. The fluid used in the fluid bearing may be supplied through a piston assembly, a cylinder, or both.

**FIG. 13** shows a perspective view of a portion of an illustrative piston assembly **1300** with a bearing element **1310** having holes **1312**, in accordance with some embodiments of the present disclosure. Holes **1312** may be arranged in a pattern, arranged randomly, or any combination thereof. Holes **1312** may have any suitable dimensions. For example, in some embodiments, holes **1312** may range from thousandths of an inch or less, to an eighth of an inch or larger. In some embodiments, the dimensions of holes **1310** may be selected based on the relative flow restriction or effective area of

25  
30

the holes to one or more other flow restrictions or effective areas. For example, the holes may be sized to provide a flow restriction of the same order as a flow restriction of the exhaust path of the bearing fluid downstream of holes **1310**.

5 As piston assembly **1300** translates in the bore of a suitable cylinder due to forces on piston face **1302**, or other suitable piston face (not shown) of piston assembly **1300**, bearing element may aid in maintaining centering. Fluid may be supplied from any suitable fluid source, as shown by arrow  
10 **1322**, and may be distributed within piston assembly **1300** via internal fluid passages (not shown) to holes **1312**. After exiting holes **1312**, the fluid may flow through the clearance gap, and along at least a portion of piston assembly **1300**. The outward flow of fluid, shown by arrows **1320**, from bearing  
15 element **1310** may aid in preventing and/or reducing piston assembly-cylinder contact.

Although shown as holes in **FIG. 13**, any suitable ports may be used to provide fluid to the clearance gap to act as a fluid bearing. For example, a gap between mating parts may be  
20 used to provide fluid to the clearance gap. In a further example, an orifice in the shape of a ring, extending partially or fully around the circumference of the piston assembly, may be used to provide fluid to the clearance gap. In some embodiments, bearing element **1310** may include ports  
25 sufficiently small (e.g., smaller than the mean free path of the bearing fluid) to permit effusion.

**FIG. 14** shows a perspective view of a portion of an illustrative piston assembly **1400** with a porous bearing element **1410**, in accordance with some embodiments of the  
30 present disclosure. As piston assembly **1400** translates in the bore of a suitable cylinder due to forces on piston face **1402**, or other suitable piston face (not shown) of piston assembly **1400**, bearing element may aid in maintaining centering. Fluid may be supplied from any suitable fluid source, as shown by

arrow 1422, and may be distributed within piston assembly 1400 via internal fluid passages (not shown), and then may flow through void space of any suitable portion of bearing element 1410. Bearing element 1410 may have any suitable porosity and pore size. After exiting the lateral surface of bearing element 1410, the gas may flow through the clearance gap, and along at least a portion of piston assembly 1400. The outward flow of fluid from bearing, as shown by arrows 1420, element 1410 may aid in preventing and/or reducing piston assembly-cylinder contact. Bearing element 1410 may be constructed from any suitable material having porosity that may allow a fluid to flow. For example, a porous bearing element may be constructed from graphite, sintered metal (e.g., iron, steel, bronze), sintered or otherwise porous ceramic (e.g., silicon carbide, alumina, magnesia), any other suitable material sintered or otherwise, or any combination thereof. In some embodiments, bearing element 1410 may have a pore size sufficiently small (e.g., smaller than the mean free path of the bearing fluid) to permit effusion.

**FIG. 15** shows a cross-section view of an illustrative piston assembly 1500, with a fluid bearing 1510 fed through the piston assembly 1500, in accordance with some embodiments of the present disclosure. Piston assembly 1500 may include piston 1502, bearing element 1510, frame 1550, fastener 1590, any other suitable components not shown in **FIG. 15**, or any combination thereof. Piston assembly 1500 may be configured to fit in the bore of a cylinder of a piston engine, and may be configured to translate substantially along an axis on or near the centerline of the bore. Bearing element 1510 includes fluid passages 1560, which may distribute bearing fluid from one or more inlet ports 1512, as shown by arrow 1522, to one or more ports or surfaces to flow radially outwards, as shown by arrows 1520. In some embodiments, bearing element 1510 may include an assembly of multiple

components. In some embodiments, piston 1502 may optionally include a self-centering feature, or other suitable feature (not shown).

5 **FIG. 16** shows a cross-section view of an illustrative piston assembly 1610 and cylinder 1620, with fluid bearing 1612 (e.g., the fluid layer located in the clearance gap originating at least in part from bearing element 1618) fed through the piston assembly 1610, in accordance with some embodiments of the present disclosure. Piston assembly 1610  
10 includes internal passages 1614, which may receive bearing fluid 1616. Bearing element 1618 is the portion of piston assembly 1610 that includes holes or a porous portion from which bearing fluid may flow into fluid bearing 1612. Bearing element 1618 may be an integral part of a piston (as shown in  
15 **FIG. 16**), another portion of piston assembly 1610, a separate component mated to piston assembly 1610 (e.g., by press fitting or mounting with fasteners), have any other suitable arrangement, or any combination thereof. Fluid bearing 1612 may aid in centering piston assembly 1610 about axis 1650,  
20 which represents the center of the bore of cylinder 1620.

**FIG. 17** shows a cross-section view of an illustrative piston assembly 1710 and cylinder 1720, with fluid bearing 1712 fed through the cylinder 1720, in accordance with some embodiments of the present disclosure.  
25 Cylinder 1720 includes internal passages 1714, which may receive bearing fluid 1716. Bearing element 1718 is the portion of cylinder 1720 that includes holes or an effusive surface from which fluid may flow into fluid bearing 1712 in a suitable clearance gap between piston assembly 1710 and  
30 cylinder 1720. Bearing element 1718 may be an integral part of cylinder 1720 (as shown in **FIG. 17**), a separate component mated to cylinder 1720 (e.g., such as an insert or liner), have any other suitable arrangement, or any combination thereof. Fluid bearing 1712 may aid in centering piston

assembly 1710 about axis 1750, which represents the center of the bore of cylinder 1720. In some embodiments, a cylinder may include one or more bearing elements, which may provide bearing fluid to one or more corresponding fluid bearings .

5 For example, in some embodiments, the bore of a cylinder may include multiple bearing elements, each with a separate and controllable fluid source, which may feed bearing fluid into multiple locations in the bore the cylinder.

In some embodiments, blow-by gas may be routed to reduce or prevent flow of blow-by gas in the portion of a clearance gap adjacent to the bearing element. For example, blow-by gas may be routed through the cylinder, piston assembly, or both, so that the flow of blow-by gas does not substantially alter the flow of bearing fluid in the clearance gap. Some alterations of bearing gas flow by other flows such as, for example, blow-by gas, may adversely affect the ability of the bearing fluid to prevent piston-cylinder contact. Routing of the blow-by gas may, for example, allow the bearing fluid exhaust pressure to be relatively far below the fluid feed pressure (e.g., allow a larger pressure drop of the bearing fluid) , which may provide desired flow and bearing characteristics .

**FIG. 18** shows a cross-section view of an illustrative arrangement 1800 of a piston assembly 1810 and cylinder 1820, with bearing elements 1812 and 1813 and a translator 1814 having fluid passage 1875, in accordance with some embodiments of the present disclosure. Piston face 1802 may contact a gas spring (e.g., gas driver section) of arrangement 1800, while piston face 1804 may contact a combustion section of arrangement 1800. Arrangement 1800 may include stator 1815, which may interact electromagnetically with translator 1814.

In the illustrated embodiments, bearing fluid 1874 is supplied to conduit 1870, to which conduit 1872 is connected via seal 1871. Seal 1871, as illustrated in **FIG. 18**, may

allow piston assembly 1810, including conduit 1872, to translate about axis 1850, while maintaining a pressure seal between conduit 1870 and 1872. The interior of conduit 1872 is coupled to fluid passage 1875, located in translator 1814, from which bearing fluid 1874 may flow into passage 1816. Passage 1816 feeds bearing fluid 1874 to bearing elements 1812 and 1813, from which bearing fluid 1874 flows into fluid bearings within a clearance gap between piston assembly 1810 and cylinder 1820. In some embodiments (not shown), conduit 1870, conduit 1872, or both, may be flexible to allow relative motion. For example, in some embodiments (not shown), conduit 1870 may be a flexible hose connected directly to translator 1814 via a suitable hose fitting (e.g., and accordingly conduit 1872 need not be included) .

**FIG. 19** shows a cross-section view of an illustrative arrangement 1900 of a piston assembly 1910 and cylinder 1920, with bearing elements 1912 and 1913 and a valve 1970, in accordance with some embodiments of the present disclosure. Piston face 1902 may contact a gas spring (e.g., gas driver section) of arrangement 1900, while piston face 1904 may contact a combustion section of arrangement 1900. Arrangement 1900 may include stator 1915, which may interact electromagnetically with translator 1914.

In the illustrated embodiments, at least a portion of the fluid of gas spring 1976 is supplied to passage 1916 as bearing fluid via valve 1970 (e.g., as shown by arrow 1974), located in piston face 1902. Valve 1970 may include an active or passive valve, or other suitable ported device, that provide control of fluid flow in one or more directions. For example, valve 1970 may include a reed valve, ball valve, needle valve, ball check valve, diaphragm check valve, a static flow restriction within a conduit providing different resistances for different flow directions, any other suitable valve, an electronic controller or other active positioning

system, any other suitable device, or any combination thereof. Passage 1916 feeds bearing fluid 1974 to bearing elements 1912 and 1913, from which bearing fluid flows into fluid bearings within a clearance gap between piston assembly 1910 and  
5 cylinder 1920. In some embodiments, valve 1970 may be a check valve. Accordingly, as piston assembly 1910 translates along axis 1950, and as fluid is supplied and/or removed from gas spring 1976 via ports 1990 (e.g., which may include one or more valves), the pressure in gas spring 1976 may reach the  
10 cracking pressure, and the fluid may flow through valve 1970 into passage 1916. The cracking pressure of valve 1970 may be any suitable value, and in some embodiments, may be actively adjustable. In some embodiments, valve 1970 may be actively controllable, and the flow in either direction may be  
15 controlled by controlling an orifice or other flow restriction of valve 1970.

In some embodiments, a bearing element may be an integral part of a piston. For example, a piston may have a collection of machined passages and holes that provide bearing fluid to a  
20 clearance gap. In some such embodiments, the piston may, but need not, be a part of a piston assembly. A bearing element may include a graphite element, a metal element with machined features, a sintered metal element, a porous ceramic element, a nonporous ceramic element, any other suitable element of a  
25 suitable material, or any combination thereof.

[Temperature Management of Cylinder and/or Piston]

In some embodiments, the temperature of a piston (or assembly thereof), cylinder, or both may be controlled or  
30 otherwise managed. Temperature management of a piston (or assembly thereof) and/or a cylinder may aid in maintaining or otherwise managing a clearance gap, by managing thermal deformation of one or more components of a piston engine.

In some embodiments, one or more heat pipes may be used to affect heat transfer of a piston assembly. A heat pipe may include a fluid conduit configured to aid in heat transfer to and from, for example, components of a piston engine. The piston face of a piston assembly may experience elevated temperatures due to combustion. The use of a heat pipe may aid in transferring heat away from the piston face, any other suitable portion of a piston assembly, or any other suitable component, to reduce the operating temperature of the component. For example, a heat pipe may transfer heat from a piston face to a heat receptacle such as a bearing element, a clearance gap, a surface of the bore of the cylinder, a piston rod cooled by a coolant, any other suitable heat receptacle, or any combination thereof.

A heat pipe may include a fluid conduit, which may be filled with a suitable fluid such as, for example, water, ethanol, ammonia, sodium, or any other suitable fluid or mixture. The latent heat associated with a phase transition of the fluid is generally much greater than the transfer of sensible energy due to a temperature difference. Additionally, the phase transition of the fluid may occur at a substantially constant or otherwise limited temperature (which may depend on pressure and any impurities present), which may aid in reducing relatively large temperature gradients within the piston engine. The heat pipe may be arranged as part of the piston assembly, in thermal contact with the piston face of the piston assembly. In some embodiments, linear motion of a piston assembly having a heat pipe may aid in transporting the fluid within the heat pipe, thus aiding in heat transfer from a piston face to a relatively cooler portion of the piston engine.

It will be understood that the phrase "thermal contact" between components shall refer to the capability of operative heat transfer between the components. For example, a heat

pipe may be arranged in contact with a piston face, and may transfer heat from the piston face, and thus may be in "direct" thermal contact with the piston face. In a further example, a heat pipe may be in contact with a piston frame, which may be in contact with a piston face, and the heat pipe may transfer heat from the piston frame, which may transfer heat from the piston face, and thus the heat pipe may be in "indirect" thermal contact with the piston face.

**FIG. 20** shows a cross-section view of an illustrative piston assembly **2010** and cylinder **2020**, of piston engine **2000**, with a heat pipe **2080** included as part of the piston assembly, in accordance with some embodiments of the present disclosure. Heat pipe **2080**, which may be a pipe or other fluid conduit, may include fluid **2082**, which may undergo a vapor-liquid phase transition during operation of piston engine **2000**. Heat transfer (shown by arrow **2024**) may occur from combustion section **2030** to piston face **2002** during engine operation. Heat transfer (shown by arrow **2024**) may further occur from piston face **2020** to a portion **2084** of heat pipe **2080**, which may aid in reducing, maintaining, or both, the temperature of piston face **2020**. Heat transfer within heat pipe **2080** may occur from portion **2084** of heat pipe **2080** to portion **2086** of heat pipe **2080**. Portion **2086** may transfer heat to a portion of piston assembly **2010** away from piston face **2002** such as, for example, the end of cylinder **2020** distal to combustion section **2030** and relatively near portion **2086**. For example, heat pipe **2080** may aid in transferring heat **2024** from combustion section **2030** radially outward to a bearing face, the clearance gap and then the cylinder, where it may be further transferred, for example, via coolant in a coolant passage. In a further example, heat pipe **2080** may aid in transferring heat from combustion section **2024** to gas driver section **2040** of cylinder **2020**.

**FIG. 21** shows a cross-section view of an illustrative piston assembly **2100** with a heat pipe **2180** formed by an interior void, in accordance with some embodiments of the present disclosure. Piston assembly **2100** may include piston **2102**, element **2110**, frame **2150**, fastener **2190**, any other suitable components not shown in **FIG. 21**, or any combination thereof. Piston assembly **2100** may be configured to fit in the bore of a cylinder of a piston engine, and may be configured to translate substantially along an axis on or near the centerline of the bore. Element **2110** may include (although not shown) a bearing element (e.g., with bearing passages), piston rings, a frame, any other suitable components, any other suitable features, or any combination thereof. Fluid within heat pipe **2180** may be filled, vented, or otherwise adjusted using port **2182**, which may include a valve (e.g., a check valve, or shut-off valve), plug, or other component. In some embodiments, heat pipe **2180**, with port **2182**, may be capable of being filled, vented, or otherwise adjusted during operation of the piston engine. In some embodiments, heat pipe **2180**, with port **2182**, need not be capable of being filled, vented, or otherwise adjusted during operation of the piston engine, and may accordingly be adjusted while the piston engine is not operating.

In some embodiments, multiple heat pipes may be included on a diameter near the perimeter of a piston assembly to aid in transferring heat from a piston face to a clearance gap and an inner cylinder wall. In an illustrative example, six to twelve heat pipes may be oriented axially, arranged on a diameter near the perimeter of a piston assembly, although any suitable number of heat pipes may be used in such an annular arrangement. In some embodiments, an annular heat pipe may be included in a piston assembly to aid in transferring heat to the clearance gap. For example, an annular void within a

piston assembly may be filled with a suitable fluid and sealed during operation.

**FIG. 22** shows a cross-section view of an illustrative piston engine **2200** having a piston assembly **2210**, and a  
5 cylinder **2220** having coolant passages **2222** and **2238** and heat pipes **2224**, in accordance with some embodiments of the present disclosure. In some embodiments, piston engine **2200** may include coolant passages **2222** to aid in controlling or otherwise limiting the temperatures of one or more components  
10 of piston engine **2200**. Temperature control may also be used to control a size and/or shape of a cylinder bore (e.g., by controlling thermal deformation), which may improve or otherwise adjust blow-by characteristics and/or bearing performance. As shown illustratively in **FIG. 22**, cylinder  
15 **2220** may include internal passages, fed by one or more ports, which may supply and return a coolant fluid, as shown by arrows **2230** and **2234**, and arrows **2232** and **2236**, respectively. As shown, coolant passages **2222** and coolant passages **2238** include annular voids, although any suitable arrangement may  
20 be used in accordance with the present disclosure. In some embodiments, a coolant such as ethylene glycol, propylene glycol, water, alcohol, air, any other suitable fluid, or any combination thereof (e.g., ethylene glycol diluted with water) may be supplied to coolant passages **2222** and **2238**. In some  
25 embodiments (not shown), piston engine **2200** may include a coolant subsystem which may include a pump, radiator, temperature regulator, pressure regulator, fluid handling conduits, any other suitable components, or any combination thereof. In some embodiments, coolant passages **2222** and  
30 coolant passages **2238** may be interconnected within cylinder **2220**, and accordingly may be controlled as a single set of passages. In some embodiments, coolant passages **2222** and coolant passages **2238** need not be interconnected within cylinder **2220**, and may be separately controllable. For

example, in some embodiments, coolant passages **2222** and coolant passages may aid in selectively cooling different zones of cylinder **2220**, and accordingly each zone may be cooled separately. In an illustrative example, a control system may determine that a clearance gap between piston assembly **2210** and cylinder **2220**, when the piston is in combustion section **2270**, is too large. Accordingly, the flow rate of coolant supplied to coolant passages **2222**, relatively nearer to TDC than coolant passages **2238**, may be increased to cool the cylinder and reduce the bore (via thermal contraction), and hence reduce the clearance gap. Any suitable number of separate coolant passages may be used to provide selective cooling, arranged in any suitable configuration, in accordance with the present disclosure. In some embodiments, cylinder **2220** may include one or more heat pipes **2224** to aid in controlling or otherwise limiting the temperatures of one or more components of piston engine **2200**. One or more heat pipes **2224** may be included in any suitable arrangement in cylinder **2220**, and may include any suitable heat pipe fluid. For example, one or more heat pipes **2224** may include multiple heat pipes arranged axially on a diameter centered at the center of the bore of cylinder **2220**. In a further example, one or more heat pipes **2224** may include an annular void within cylinder **2220**. Heat pipe ports **2226** may be used, in some embodiments, to supply, remove, or otherwise control fluid within one or more heat pipes **2224**. For example, heat pipe ports **2226** may include valves, regulators, orifices, any other suitable features or devices, or any combination thereof to control properties of the one or more heat pipes **2224**, or fluid contained therein. In some embodiments, coolant passages **2222** and/or coolant passages **2238** may directly contact (not shown) one or more heat pipes **2224**, and may provide relatively increased heat transfer from the one or more heat pipes **2224**. Although coolant passages

**2222** and **2238** and one or more heat pipes **2224** are shown in **FIG. 22**, some embodiments (not shown in **FIG. 22**) may include either coolant passages and one or more heat pipes, and accordingly need not include both. The use of coolant passages **2222** and **2238** and one or more heat pipes **2224** together may, in some arrangements, provide relatively enhanced heat transfer as compared to the use of either alone. For example, heat may be transferred from the bore of cylinder **2220** to the one or more heat pipes **2224** via the clearance gap, and one or more heat pipes **2224** may transfer at least a portion of this heat to coolant within coolant passages **2222** and/or coolant passages **2238** (e.g., the heat transfer may include conduction through a portion of cylinder **2220**).

In some embodiments, fluid supplied to any of ports **2250** may be used to cool piston assembly **2210**, or portions thereof. For example, heat from a piston face of piston assembly **2210** may be transported to a piston rod of piston assembly **2210**, and fluid supplied to any of ports **2250** may convectively cool a piston rod of piston assembly **2210**.

In some embodiments, fluid bearings may aid in cooling of a piston assembly, cylinder, components thereof, any other suitable components of a piston engine, or any combination thereof. A bearing fluid may be supplied to a bearing element, which may direct the bearing fluid to a suitable clearance gap of a piston-cylinder assembly. The bearing fluid may aid in cooling at least a portion of the piston-cylinder assembly as it flows through the clearance gap. In some embodiments, the bearing fluid may flow substantially away from a combustion section through a clearance gap, and accordingly may carry heat away from the combustion section thus reducing the temperature of one or more components of the piston engine. In some embodiments, convection of bearing fluid through a clearance gap of a piston engine may increase the effective heat transfer rate between a piston face and

another portion of a piston assembly and/or a cylinder. In some embodiments, one or more heat pipes may be included in a piston assembly having a bearing element. The one or more heat pipes may aid in maintaining the bearing element, or a portion of the bearing element thereof, nearly isothermal, which may aid in controlling thermal expansion and associated changes in a clearance gap. In some embodiments, the use of one or more heat pipes, coolant passages, bearing elements, any other suitable components, or any combination thereof, may aid in maintaining or otherwise managing a clearance gap, by managing thermal deformation of one or more components of a piston engine.

[Cylinder Liner]

In some embodiments, a clearance gap between a free piston and a cylinder may be controlled or otherwise managed. In some embodiments, a deformable cylinder liner may be used to adjust the clearance gap by adjusting the bore in which a piston assembly moves. In some embodiments, a liner fluid may be used to apply pressure to the deformable cylinder liner, which may deform based on a pressure difference between the faces of the cylinder liner. Liner fluid may include, for example, water, ethylene glycol, propylene glycol, oil, hydraulic fluid, fuel (e.g., diesel fuel), any other suitable fluid, or any suitable combination thereof.

**FIG. 23** shows a cross-section view of an illustrative piston assembly **2310** and cylinder **2320**, with a deformable cylinder liner **2330**, in accordance with some embodiments of the present disclosure. The interior surface of deformable cylinder liner **2330** may define a bore, in which piston assembly **2310**, or a portion thereof, may translate along axis **2350** at the center of the bore. Passages **2322** may be formed between cylinder **2320** and deformable cylinder liner **2330**, into which a liner fluid may be supplied and/or returned via ports

**2324.** The liner fluid, controlled to a suitable pressure may impart a deforming force to deformable cylinder liner **2330**, allowing the bore to be adjusted accordingly. The clearance gap **2360** between the bore and piston assembly **2310** may

5 accordingly be adjusted by application of the liner fluid at a suitable pressure. Increasing the pressure of the liner fluid (e.g., by supplying liner fluid to passages **2322** via one or more of ports **2324**) may reduce the bore and clearance gap **2360**, while decreasing the pressure of the liner fluid (e.g.,

10 by removing liner fluid from passages **2322** via one or more of ports **2324**) may increase the bore and clearance gap **2360**.

**FIG. 24** shows a cross-section view of the illustrative piston assembly **2310** and cylinder **2320** of **FIG. 23**, with the deformable cylinder liner **2330** undergoing deformation, in

15 accordance with some embodiments of the present disclosure. The liner fluid pressure is larger in passages **2322** as shown in **FIG. 24** relative to that shown in **FIG. 23**, and accordingly clearance gap **2460** is relatively smaller than clearance gap **2360**.

20 **FIG. 25** shows a cross-section view of an illustrative piston assembly **2510** and cylinder **2520**, with a sectioned deformable cylinder liner **2530**, in accordance with some embodiments of the present disclosure. The interior surface of deformable cylinder liner **2530** may define a bore, in which

25 piston assembly **2510**, or a portion thereof, may translate along axis **2550** at the center of the bore. Passages **2522** and **2523** may be formed between cylinder **2520** and deformable cylinder liner **2530**, which may be separated by seal **2532**. A liner fluid may be supplied to and/or returned from passages

30 **2522** and **2523** via ports **2524** and ports **2525**, respectively, which may be, but need not be, isolated from each other. Liner fluid, controlled to a suitable pressure, may impart a deforming force to deformable cylinder liner **2530**, allowing the bore at each section (i.e., the portion of the bore

corresponding to passages **2522** or **2523**) to be adjusted accordingly. In some embodiments, the pressure of the liner fluid may be controlled based at least in part on the pressure within a suitable section of the bore, as the deformation of deformable cylinder liner **2530** may depend on a differential pressure between the liner fluid and the bore. The clearance gap **2560** between the bore and piston assembly **2510** may accordingly be adjusted by application of the liner fluid at a suitable pressure. The clearance gap may vary in the axial direction (i.e., parallel to axis **2550**), because the clearance gap corresponding to each of passages **2522** and **2523** may be adjusted independently. For example, in some embodiments, as piston **2512** travels through a section of deformable cylinder liner **2530**, the clearance gap may be adjusted at that section. Increasing the pressure of the liner fluid (e.g., by supplying liner fluid to passages **2522** and/or **2523** via one or more of respective ports **2524** and/or **2525**) may reduce the bore and clearance gap **2560** at one or more locations, while decreasing the pressure of the liner fluid (e.g., by removing liner fluid from passages **2522** and/or **2523** via one or more of respective ports **2524** and/or **2525**) may increase the bore and clearance gap **2560** at one or more locations .

**FIG. 26** shows a cross-section view of an illustrative piston engine **2600**, with a deformable cylinder liner **2630**, in accordance with some embodiments of the present disclosure. Passages **2622** may be formed between cylinder **2620** and deformable cylinder liner **2630**, into which a liner fluid may be supplied and/or returned via ports **2624**. The liner fluid, controlled to a suitable pressure may impart a deforming force to deformable cylinder liner **2630**, allowing the bore to be adjusted accordingly. In the illustrated embodiment, ports **2626** (e.g., which may provide fuel and/or air, or receive exhaust) may be located outside of deformable cylinder liner **2630** to eliminate the need for ports or other openings in

deformable cylinder liner **2630**. Adjustment of a clearance gap between piston assembly **2610** and deformable cylinder liner **2630** may be achieved by adjustment of the pressure of the liner fluid in passages **2622**.

5 In some embodiments, flow of a liner fluid may be used to provide cooling for a deformable cylinder liner. For example, a pressure-controlled and flow-controlled liner fluid may be used to provide convective heat transfer away from a deformable cylinder liner (e.g., near a combustion section) to  
10 the liner fluid. Cooling with the use of a liner fluid may be used in concert with, or in place of, cooling with the use of coolant passages and/or heat pipes (e.g., as shown in **FIG. 22**).

**FIG. 27** shows a cross-section view (normal to the bore axis) of a portion of an illustrative piston engine **2700**, with localized coolant passages **2752** and **2754**, in accordance with some embodiments of the present disclosure. Cylinder **2720** of piston engine **2700** may include one or more plenums **2722**, which may be coupled to one or more throttles **2724** and one or more  
20 throttles **2726**. In some embodiments, a throttled fluid may flow from one or more plenums **2722** through one or more throttles **2724** into coolant passages **2752**, configured to cool region **2732** (e.g., as shown by the illustrative arrows in coolant passages **2752**). In some embodiments, a throttled  
25 fluid may flow from one or more plenums **2722** through one or more throttles **2726** into coolant passages **2754**, configured to cool region **2734** (e.g., as shown by the illustrative arrows in coolant passages **2754**). One or more throttles **2724** and **2726** may each include a fixed flow restricting orifice, an  
30 adjustable flow restricting orifice, a controllable throttling valve, any other suitable fluid throttling feature, or any combination thereof. The one or more throttles **2724** and **2726** may cause a reduction in the pressure of the throttled fluid, which may also result in a reduction in temperature and/or

enthalpy of the throttled fluid. The reduced fluid temperature and/or enthalpy may enhance heat transfer from a bore of cylinder **2720** (e.g., the illustrated bore configured to house piston assembly **2710**). In some embodiments, coolant passages **2752** and **2754** may include tubular conduits, manifolds, or other flow directing components to provide a flow of throttled fluid from one or more throttles **2724** and **2726** to a localized spatial region of cylinder **2720**, and then return the fluid to a fluid control system (e.g., which may include a return line and a reservoir). Piston engine **2700** may include any suitable number of plenums **2722**, which may be, but need not be, interconnected. For example, plenums **2722** may include multiple plenums, each separately controllable to provide selectable cooling to localized spatial regions of cylinder **2720**. In a further example, plenums **2722** may include a single plenum, which may be coupled to multiple throttles to provide selectable cooling to localized spatial regions of cylinder **2720**. The multiple throttles may be separately controllable, or otherwise have unique flow restricting properties to control cooling of one or more localized spatial regions of cylinder **2720**. In some embodiments, cooling of cylinder **2720** using a throttled fluid may allow control of a cylinder temperature, and a clearance gap between cylinder **2720** and piston assembly **2710**. In some embodiments, direct or indirect measurement of bore geometry (e.g., size, shape or both) may be used to by a control system to control cooling by localized coolant passages **2752** and **2754**. For example, higher operating temperatures may be expected near combustion section **2730**, near TDC, and increased cooling may be provided to region **2732** to limit the temperature field. In a further example, in some circumstances, decreased cooling may be provided to region **2732** to increase the corresponding bore and associated clearance gap. Increases or decreases in cooling may be provided by increasing or decreasing the throttling

action of a throttle, adjusting a throttled fluid's temperature, adjusting a throttled fluid's flow rate, any other suitable adjustment, or any combination thereof. The throttled fluid may include any suitable coolant fluid, which  
5 may be a liquid or a gas. For example, the throttled fluid may include ethylene glycol, propylene glycol, water, alcohol, air, any other suitable fluid, or any combination thereof (e.g., ethylene glycol diluted with water). Cylinder 2720 may include any suitable ports 2770 for supplying or removing  
10 fluid (e.g., air, fuel, exhaust, or combinations thereof) from suitable sections of piston engine 2700.

**FIG. 28** shows a cross-section view (parallel to the bore axis) of a portion of an illustrative piston engine 2800, with localized coolant passages 2826, in accordance with some  
15 embodiments of the present disclosure. Piston engine 2800 may include cylinder 2820 having a plenum 2822. Cylinder 2820 may include a bore configured to house piston assembly 2810, configured to move substantially linearly, in a direction substantially parallel to the vector cross-product of vectors  
20 2850 and 2860. Although shown as an annular plenum in **FIG. 28**, plenum 2822 may include any suitable conduit shape, arranged to provide any suitable flow path. A coolant may flow through throttles 2824, into localized coolant passages 2826 to cool corresponding spatial regions of cylinder 2820.  
25 In the illustrated embodiment, the coolant flows radially inward from throttles 2824 (as shown by the four arrows pointing radially inward in figure **FIG. 28**) and then flows in a direction given by the vector cross-product of vector 2850 with vector 2860 ( $2850 \times 2860$  which is into the plane of **FIG. 28**).  
30 The return flow path of the coolant is not shown in **FIG. 28**, and may include radial, axial, or both, flow paths. In some embodiments, throttles 2824 may create fluid jets in localized fluid passages 2826, which may impinge on a spatial region of cylinder 2820 resulting in relatively increased

convective heat transfer at that region. Although shown as having four, symmetric localized coolant passages **2826** in **FIG. 28**, piston engine **2800** may include any suitable number of localized coolant passages, arranged in any suitable symmetric or asymmetric configuration, at any suitable axial locations, and coupled to any suitable number of plenums or other coolant sources .

**FIG. 29** shows a cross-section view of a portion of an illustrative piston engine **2900**, with localized heat sources including electric heaters **2922**, **2923**, **2924**, **2925**, **2926**, and **2927**, in accordance with some embodiments of the present disclosure. Each of electric heaters **2922**, **2923**, **2924**, **2925**, **2926**, and **2927** may include one or more electric leads used by a suitable control system to control a voltage, current, electric power, or combinations thereof, supplied to the heaters. For example, electric heaters **2922** and **2923** may be used separately or in concert to provide heating to region **2932** near combustion section **2930** (e.g., to increase a clearance gap between cylinder **2920** and piston assembly **2910**) . In a further example, electric heaters **2924**, **2925**, **2926**, and **2927** may be used to heat corresponding regions **2934** and **2936**. Localized heat sources, such as electric heaters, may be used to provide relatively fast thermal control of one or more spatial regions of a cylinder. In some embodiments, direct or indirect measurement of bore geometry (e.g., size, shape or both) may be used to by a control system to control localized heat sources. For example, each of electric heaters **2922**, **2923**, **2924**, **2925**, **2926**, and **2927** may be separately controllable by a control system, in response to a detected temperature, pressure, clearance gap, blow-by property, work interaction, any other suitable indicator, or any combination thereof. Cylinder **2920** may include any suitable ports **2970** for supplying or removing fluid (e.g., air, fuel, exhaust, or

combinations thereof) from suitable sections of piston engine 2900.

**FIG. 30** shows a cross-section view of a portion of an illustrative piston engine 3000, including fluid passages 3022 and 3024, which may be used for heating, cooling, or both, in accordance with some embodiments of the present disclosure. In some embodiments, a heating fluid, cooling fluid, or both, may be supplied to fluid passages 3022 and 3024, which may be, but need not be, interconnected. For example, fluid may be supplied to and removed from fluid passages 3022 and 3024 as shown by the four arrows in **FIG. 30** (e.g., for annular fluid passages having supply and return ports). In some embodiments, fluid passages 3022 and 3024 may be localized heating sources. For example, fluid passages 3022 and 3024 may be separately controllable to provide heating to respective regions 3032 and 3034. Fluid passages 3022 or 3024 may provide heating by acting as a conduit for a heating fluid, which may include, for example, previously heated coolant, exhaust fluid (e.g., hot combustion products from a combustion section), any other suitable heating fluid, or any combination thereof. In some embodiments, fluid passages 3022 and 3024 may be used for both heating and cooling of spatial regions of cylinder 3020. For example, a heating fluid may be supplied to fluid passages 3022 to increase a temperature of region 3032 (e.g., to increase a bore diameter and clearance gap), while a cooling fluid may be supplied to fluid passages 3024 to decrease a temperature of region 3034 (e.g., to decrease a bore diameter and clearance gap). In a further example, a heating fluid or coolant may be supplied to fluid passages 3022 depending on a determination of a control system. Cylinder 3020 may include any suitable ports 3070 for supplying or removing fluid (e.g., air, fuel, exhaust, or combinations thereof) from suitable sections of piston engine 3000.

In some embodiments, a cylinder may be configured to undergo a thermal deformation corresponding to a controlled temperature, or change thereof, of the cylinder, such as, for example, those described in the context of **FIGS. 22 and 27-30**.

5 A controlled temperature, or change thereof, may correspond to a localized spatial region of the cylinder. The use of a coolant, a heating fluid, a throttled fluid, an electric resistance heater, any other suitable component or feature for controlling temperature, or any combination thereof may allow

10 a control system to control one or more properties of a piston engine such as, for example, a clearance gap.

[Combination of Approaches]

In some embodiments, two or more of the foregoing

15 approaches may be combined. Self-centering features, fluid bearings, heat pipes, coolant passages, deformable cylinder liners, and any other suitable component or feature, may be suitably combined in implementing a piston engine, in accordance with the present disclosure.

20 For example, **FIG. 31** shows a perspective view of a portion of an illustrative piston assembly **3100** having seal **3104**, fluid bearing element **3108**, and a self-centering feature **3106**, in accordance with some embodiments of the present disclosure. Piston assembly **3100** may include piston face **3102**, seal **3104**,

25 self-centering feature **3106**, fluid bearing element **3108**, any other suitable components (not shown), or any combination thereof. In some embodiments (as shown), self-centering feature **3106** may be a part of seal **3104**. For example, seal **3104** may include self-centering feature **3106**, which may be a

30 machined step or other suitable feature in the bearing element. In some embodiments (not shown), self-centering feature **3106** may be a part of piston face **3102**. For example, self-centering feature **3106** may be a step, one or more slotted pockets, a tapered portion, or other feature included in

piston assembly **3100**. Gas supplied from any suitable fluid source, may be distributed within piston assembly **3100** via internal fluid passages (not shown), and then may flow through any suitable portion of fluid bearing element **3108** (shown as porous in **FIG. 31**, but any suitable bearing element may be used) .

In a further example, **FIG. 32** shows a cross-section view of an illustrative piston engine **3200** with a piston assembly **3210** having a bearing element **3214**, a heat pipe **3250**, and a self-centering feature **3212**, and a cylinder **3230** having a deformable cylinder liner **3232** and coolant passages **3236**, in accordance with some embodiments of the present disclosure. Piston assembly **3210** may be configured to translate in the bore created by deformable cylinder liner **3232**, with clearance gap **3260**. Application of a liner fluid, controlled to a suitable pressure, may be supplied to passage **3234**, via port **3233**, to adjust clearance gap **3260**. Bearing fluid may be supplied to passages **3218**, and flow out of bearing element **3214** into clearance gap **3260** to aid in centering piston assembly **3210** in the bore. Self-centering feature **3212** may aid in centering piston assembly **3210** in the bore. A suitable coolant may be supplied to coolant passages **3236** in cylinder **3230** to remove heat from cylinder **3230** or portions thereof. Heat pipe **3250**, having fill port **3282**, may aid in transferring heat away from piston face **3202** to another portion of piston assembly **3210**. Ports **3270** may be used to supply oxidizer and/or fuel, supply and/or remove driver gas, or remove exhaust from a section of the cylinder. In some embodiments, a combination of one or more approaches may require one or more additional considerations. For example, in some embodiments, a piston assembly may include a self-centering feature configured to provide a self-centering force using blow-by gas, and a bearing element configured to provide a bearing fluid to a clearance gap. The self-centering

feature thus may require some blow-by gas to flow along the clearance gap to provide the self-centering force. Under some conditions, flow of blow-by gas in the clearance gap may affect the performance of the bearing element by altering the flow pattern of the bearing fluid in the clearance gap.

Accordingly, in some embodiments having a bearing element behind the self-centering feature (relative to the combustion section), blow-by gas may be routed away from the clearance gap after traversing the portion of the clearance gap adjacent to the self-centering feature, but before entering the portion of the clearance gap adjacent to the bearing element.

Further, in some arrangements, a bearing element may include a self-centering feature, and a collection of holes for directing bearing fluid that may extend to the piston face.

Accordingly, in some such embodiments, no routing of the blow-by gas away from the clearance gap need be used. The previous examples may optionally be applied to a gas driver section in addition to or instead of a combustion section.

#### [Control of Clearance Gap and/or Other Properties]

In some embodiments, one or more aspects of the operation of a piston engine may be controlled or otherwise managed to affect a temperature, clearance gap, any other suitable property of the piston engine, or any combination thereof. In some embodiments, controlling a temperature, pressure, or other suitable property of a piston engine may aid in managing a clearance gap of the piston engine. For example, relatively large temperature differences may cause deformation such as expansion of some components of a piston engine, which may affect a clearance gap. Controlling temperature differences and/or temperature fields may aid in reducing deformation, and accordingly may aid in managing the clearance gap. Managing a clearance gap may include managing any other suitable property that may affect a clearance gap.

**FIG. 33** is a block diagram of an illustrative control arrangement **3300** for a piston engine **3340**, in accordance with some embodiments of the present disclosure. A control system **3310** may communicate with one or more sensors **3330** coupled to piston engine **3340**. Control system **3310** may be configured to communicate with auxiliary systems **3320**, which may be used to adjust aspects or properties of piston engine **3340**. In some embodiments, control system **3310** may be configured to interact with a user via user interface system **3350**.

Control system **3310** may include processing equipment **3312**, communications interface **3314**, sensor interface **3316**, control interface **3318**, any other suitable components or modules, or any combination thereof. Control system **3310** may be implemented at least partially in one or more computers, terminals, control stations, handheld devices, modules, any other suitable interface devices, or any combination thereof. In some embodiments, the components of control system **3310** may be communicatively coupled via a communications bus **3311**, as shown in **FIG. 33**. Processing equipment **3312** may include a processor (e.g., a central processing unit), cache, random access memory (RAM), read only memory (ROM), any other suitable components, or any combination thereof that may process information regarding piston engine **3340**, as received by sensor interface **3316** from sensor (s) **3330**. Sensor interface **3316** may include a power supply for supplying power to sensor (s) **3330**, a signal conditioner, a signal pre-processor, any other suitable components, or any combination thereof. For example, sensor interface **3316** may include a filter, an amplifier, a sampler, and an analog to digital converter for conditioning and pre-processing signals from sensor (s) **3330**. Sensor interface **3316** may communicate with sensor (s) **3330** via communicative coupling **3319**, which may be a wired connection (e.g., using IEEE 802.3 ethernet, or universal serial bus interface), wireless coupling (e.g.,

using IEEE 802.11 "Wi-Fi", or Bluetooth), optical coupling, inductive coupling, any other suitable coupling, or any combination thereof. Control system **3310**, and more particularly processing equipment **3312**, may be configured to provide control of piston engine **3340** over relevant time scales. For example, a change in one or more temperatures may be controllable in response to one or more detected engine operating parameters, and the control may be provided on a time scale relevant to operation of the piston engine (e.g., fast enough response to prevent overheating and/or component failure) .

Sensor <sub>(s)</sub> **3330** may include any suitable type of sensor, which may be configured to sense any suitable property or aspect of piston engine **3340**. In some embodiments, sensor <sub>(s)</sub> may include one or more sensors configured to sense an aspect and/or property of a system of auxiliary systems **3320**. In some embodiments, sensor <sub>(s)</sub> **3330** may include a temperature sensor (e.g., a thermocouple, resistance temperature detector, thermistor, or optical temperature sensor) configured to sense the temperature of a component of piston engine **3340**, a fluid introduced to or recovered from piston engine **3340**, or both. In some embodiments, sensor <sub>(s)</sub> **3330** may include one or more pressure sensors (e.g., piezoelectric pressure transducers) configured to sense a pressure within a section of piston engine **3340** (e.g., a combustion section, or gas driver section) , of a fluid introduced to or recovered from piston engine **3340**, or both. In some embodiments, sensor <sub>(s)</sub> **3330** may include one or more force sensors (e.g., piezoelectric force transducers) configured to sense a force within piston engine **3340** such as a tensile, compressive or shear force (e.g., which may indicate a friction force or other relevant force information) . In some embodiments, sensor <sub>(s)</sub> **3330** may include one or more current and/or voltage sensors (e.g., an ammeter and/or voltmeter coupled to a LEM of piston engine **3340**)

configured to sense a voltage, current, work output and/or input (e.g., current multiplied by voltage), any other suitable electrical property of piston engine **3340** and/or auxiliary systems **3320**, or any combination thereof.

5 Control interface **3318** may include a wired connection (e.g., using IEEE 802.3 ethernet, or universal serial bus interface), wireless coupling (e.g., using IEEE 802.11 "Wi-Fi", Bluetooth, or other RF communication protocol), optical coupling, inductive coupling, any other suitable coupling, or  
10 any combination thereof, for communicating with one or more of auxiliary systems **3320**. In some embodiments, control interface **3318** may include a digital to analog converter to provide an analog control signal to any or all of auxiliary systems **3320**.

15 Auxiliary systems **3320** may include a cooling system **3322**, a pressure control system **3324**, a gas driver control system **3326**, and/or any other suitable control system **3328**. Cooling/heating system **3322** may include a pump, fluid reservoir, pressure regulator, bypass, radiator, fluid  
20 conduits, electric power circuitry (e.g., for electric heaters), any other suitable components, or any combination thereof to provide cooling, heating, or both to piston engine **3340**. Pressure control system **3324** may include a pump, compressor, fluid reservoir, pressure regulator, fluid  
25 conduits, any other suitable components, or any combination thereof to supply (and optionally receive) a pressure controlled fluid to piston engine **3340**. Gas driver control system **3326** may include a compressor, gas reservoir, pressure regulator, fluid conduits, any other suitable components, or  
30 any combination thereof to supply (and optionally receive) a driver gas to piston engine **3340**. In some embodiments, other system **3328** may include a valving system such as, for example, a cam-operated system or a solenoid system to supply oxidizer and/or fuel to piston engine **3340**.

User interface **3315** may include a wired connection (e.g., using IEEE 802.3 ethernet, or universal serial bus interface, tip-ring-seal RCA type connection), wireless coupling (e.g., using IEEE 802.11 "Wi-Fi", Infrared, or Bluetooth), optical  
5 coupling, inductive coupling, any other suitable coupling, or any combination thereof, for communicating with one or more of user interface systems **3350**. User interface systems **3350** may include display **3352**, keyboard **3354**, mouse **3356**, audio device **3358**, any other suitable user interface devices, or any  
10 combination thereof. Display **3352** may include a display screen such as, for example, a cathode ray tube screen, a liquid crystal display screen, a light emitting diode display screen, a plasma display screen, any other suitable display screen that may provide graphics, text, images or other  
15 visuals to a user, or any combination of screens thereof. In some embodiments, display **3352** may include a touchscreen, which may provide tactile interaction with a user by, for example, offering one or more soft commands on a display screen. Display **3352** may display any suitable information  
20 regarding piston engine **3340** (e.g., a time series of a property of piston engine **3340**), control system **3310**, auxiliary systems **3320**, user interface system **3350**, any other suitable information, or any combination thereof. Keyboard **3354** may include a QWERTY keyboard, a numeric keypad, any  
25 other suitable collection of hard command buttons, or any combination thereof. Mouse **3356** may include any suitable pointing device that may control a cursor or icon on a graphical user interface displayed on a display screen. Mouse **3356** may include a handheld device (e.g., capable of moving in  
30 two or three dimensions), a touchpad, any other suitable pointing device, or any combination thereof. Audio device **3358** may include a microphone, a speaker, headphones, any other suitable device for providing and/or receiving audio signals, or any combination thereof. For example, audio

device **3358** may include a microphone, and processing equipment **3312** may process audio commands received via user interface **3315** caused by a user speaking into the microphone.

In some embodiments, control system **3310** may be configured to provide manual control, by receiving one or more user inputs. For example, in some embodiments, control system **3310** may override automatic control setting based on sensor feedback, and base a control signal to auxiliary system **3320** on one or more user inputs to user interface system **3350**. In a further example, a user may input a set-point value for one or more control variables (e.g., temperatures, pressures, flow rates, work inputs/outputs, or other variables) and control system **3310** may execute a control algorithm based on the set-point value.

In some embodiments, operating characteristics (i.e., a collection of desired property values of piston engine **3340** or auxiliary systems **3320**) may be pre-defined by a manufacturer, user, or both. For example, particular operating characteristics may be stored in memory of processing equipment **3312**, and may be accessed to provide one or more control signals. In some embodiments, one or more of the operating characteristics may be changed by a user. Arrangement **3300** may be used to maintain, adjust, or otherwise manage those operating characteristics.

**FIG. 34** is a flow diagram **3400** of illustrative steps for adjusting a clearance gap of a piston engine, in accordance with some embodiments of the present disclosure.

Step **3402** may include detecting a clearance gap indicator using sensor (s) **3330**. The clearance gap indicator may be a temperature (e.g., of a coolant, hating fluid, cylinder, piston, or other component, or portion thereof), pressure, force, distance (e.g., a clearance gap), work interaction (e.g., electromagnetic work output), material (e.g., blow-by or property thereof) any other suitable detectable property,

or any combination thereof. Sensor interface **3316** may receive, condition, and/or pre-process the clearance gap indicator from sensor <sup>(s)</sup> **3330**, and output a sensor signal to processing equipment **3312**. In some embodiments, a clearance gap indicator may be stored and correlated to one or more operating conditions of a piston engine. For example, cylinder temperature may be correlated with fuel flow, and stored as a mathematical expression or table. Accordingly, step **3402** may include detecting the one or more operating conditions of the piston engine, and recalling a stored cylinder temperature value, which may be used for further processing .

Step **3404** may include processing equipment **3312** determining a control response based at least in part on the detected clearance gap indicator of step **3402**. Processing equipment **3312** may receive the sensor signal from sensor interface **3316**, and perform one or more processing functions on the sensor signal. Processing functions may include inputting the sensor signal values in an equation or other mathematical expression, using the sensor signal values in a look-up table or other database, any other suitable processing, or any combination thereof. Processing equipment **3312** may determine a control response based on output of the one or more processing functions. For example, a calculated value may be compared to a pre-defined threshold to determine a suitable control response. In a further example, one or more calculated values may inputted into a control algorithm (e.g., a proportional-integral-derivative (PID) control algorithm) , and one or more control signal values may be determined .

Step **3406** may include processing equipment **3312** providing a control signal, based at least in part on the determined control response of step **3404**, to one or more of auxiliary systems **3320**, using control interface **3318**. The control

signal may be an analog signal, a digital signal, or a combination thereof (e.g., an analog signal with a digital timing signal), which may be provided as an electrical signal (e.g., using wired cables), an electromagnetic signal (e.g., using IEEE 802.11 "Wi-Fi", or Bluetooth receivers/transmitters), an optical signal (e.g., using fiber optic cables), inductive signal (e.g., using suitable conductive coils), or other suitable signal type.

Step **3408** may include the one or more of auxiliary systems **3320** that received a control signal at step **3406** adjusting a clearance gap, or other property, of piston engine **3340**. The one or more of auxiliary systems **3320** may adjust a pressure, temperature, flow rate, flow route, current, voltage, electric power, make any other suitable adjustment, or any combination thereof based on the provided control signal. As shown by the dotted arrow in **FIG. 34**, any or all of steps **3402-3408** may be repeated to allow closed-loop control. In some embodiments, an open-loop approach may be used, in which step **3402** may be (but need not be) omitted, and steps **3404-3408** are performed without looping.

In some arrangements, the temperature field of a cylinder and/or piston assembly, or fluid contained therein, of a piston engine may be a primary and convenient indicator of a clearance gap, and the temperature field may accordingly be actively adjusted to adjust the clearance gap. In an illustrative example, step **3402** may include detecting a temperature such as, for example, a cylinder temperature or a coolant temperature (e.g., of coolant provided to coolant passages of a cylinder of a piston engine). Step **3404** may include determining how to adjust the temperature field to maintain or otherwise manage the clearance gap, while step **3406** may include providing the corresponding control signal to the appropriate auxiliary system. For example, a cylinder temperature may be increased by reducing a coolant flow rate,

which may increase a clearance gap via thermal expansion. In a further example, a cylinder temperature may be decreased by increasing a coolant flow rate, which may decrease a clearance gap via thermal contraction. In a further example, the flow of coolant or a heating fluid in more than one set of fluid passages may be adjusted to control the temperature field of zones of a cylinder (e.g., see **FIG. 22**). In reference to the previous examples, a coolant or heating fluid flow may be adjusted by adjusting, for example, a flow control valve, a pump rotation speed, a bypass flow control valve, a pressure regulator, any other suitable control device for controlling a flow rate, or any combination thereof, based on the control signal of step **3406**. In a further illustrative example, step **3402** may include detecting a temperature such as, for example, a temperature of a heat pipe (e.g., the temperature of a heat pipe or heat pipe fluid therein) within a cylinder of a piston engine. Step **3404** may include determining how to adjust the temperature field to maintain or otherwise manage the clearance gap, while step **3406** may include providing the corresponding control signal to the appropriate auxiliary system. For example, a heat pipe temperature may be increased by increasing the pressure of the fluid within the heat pipe (e.g., by adding fluid to the heat pipe, or reducing the volume of the heat pipe), which may increase a clearance gap. In a further example, a heat pipe temperature may be decreased by decreasing a heat pipe pressure (e.g., by removing fluid from the heat pipe, or increasing the volume of the heat pipe), which may decrease a clearance gap. In reference to the previous example, properties of a fluid within a heat pipe (e.g., having a fluid port, or other adjustable feature) may be adjusted by adjusting, for example, a flow control valve, a pressure regulator, a check valve, any other suitable control device for controlling a heat pipe pressure and suitable fluid

port included in the heat pipe, or any combination thereof, based on the control signal of step **3406**.

**FIG. 35** is a flow diagram **3500** of illustrative steps for adjusting one or more properties of a piston engine, in accordance with some embodiments of the present disclosure.

In some embodiments, a clearance gap indicator may be detected using sensor (s) **3330**. Sensor interface **3316** may receive a raw signal from sensor (s) **3330** and provide a sensor signal to processing equipment **3312**. For example, step **3502** may include detecting a cylinder temperature of piston engine **3340** using a temperature sensor such as a thermocouple positioned in contact with or near a portion of the cylinder (e.g., near a combustion section). In some circumstances, increased cylinder temperatures may indicate insufficient cooling which may affect a clearance gap. In a further example, step **3504** may include detecting a piston temperature of piston engine **3340** using a temperature sensor such as a thermocouple positioned in contact with or near a portion of a piston assembly (e.g., near a piston face). In some circumstances, increased piston temperatures may indicate insufficient cooling which may affect a clearance gap. In a further example, step **3506** may include detecting a fluid (e.g., a coolant, a heating fluid, or exhaust, which may be supplied to or recovered from piston engine **3340**) temperature of piston engine **3340** using a temperature sensor such as a thermocouple positioned in contact with or near the fluid (e.g., inserted in a fluid conduit using a suitable measurement port). For example, in some circumstances, increased coolant temperatures may indicate insufficient cooling which may affect a clearance gap. In a further example, step **3507** may include detecting a pressure of a combustion section, a gas driver section, a clearance gap, a coolant, a heating fluid, any other fluid of piston engine **3340**, or any combination thereof using a pressure sensor such

as a piezoelectric transducer positioned in contact with or near the coolant (e.g., inserted in a conduit using a suitable measurement port). In a further example, step **3508** may include detecting friction between components of piston engine **3340** using a force sensor such as a piezoelectric transducer and/or a temperature sensor such as a thermocouple positioned in contact with or near the interface of the components. In some circumstances, an increased effect of friction (e.g., a friction force, or friction-generated heat) may indicate an insufficient clearance gap. In a further example, step **3509** may include detecting one or more properties of a clearance gap of piston engine **3340**. The one or more properties may include a thickness of the clearance gap (e.g., using a proximity sensor such as an induction sensor), asymmetry of the clearance gap (e.g., using multiple proximity sensors such as an induction sensors), blow-by temperature (e.g., using a temperature sensor), blow-by pressure (e.g., using a pressure sensor), blow-by composition (e.g., using a gas sensor such as an optical absorption sensor), and other suitable property, or any combination thereof. In a further example, step **3510** may include detecting a work interaction of piston engine **3340** using an electromagnetic sensor (e.g., a voltmeter, ammeter, or power meter), a pressure transducer (e.g., to detect pressure for calculating a mean effective pressure (MEP) such as indicated MEP, brake MEP, and/or friction MEP), or other suitable sensor, to provide an indication of a clearance gap. In some circumstances, a reduced work output, or increased work input requirements may indicate an insufficient and/or excessive clearance gap.

Step **3512** may include processing equipment **3312** determining a control response based at least in part on any or all of the detected clearance gap indicators of steps **3502**, **3504**, **3506**, **3508**, and **3510**. Processing equipment **3312** may receive the sensor signal from sensor interface **3316**, and

perform one or more processing functions on the sensor signal. Processing functions may include inputting the sensor signal values in an equation or other mathematical expression, using the sensor signal values in a look-up table or other database, any other suitable processing, or any combination thereof. Processing equipment **3312** may determine a control response based on output of the one or more processing functions. For example, a calculated value may be compared to a pre-defined threshold to determine a suitable control response. In a further example, one or more calculated values may be inputted into a control algorithm (e.g., a PID control algorithm), and one or more control signal values may be determined.

Step **3514** may include processing equipment **3312** providing a control signal, based at least in part on the determined control response of step **3512**, to one or more of auxiliary systems **3320**, using control interface **3318**. The control signal may be an analog signal, a digital signal, or a combination thereof (e.g., an analog signal with a digital timing signal), which may be provided as an electrical signal (e.g., using wired cables), an electromagnetic signal (e.g., using IEEE 802.11 "Wi-Fi", or Bluetooth receivers/transmitters), an optical signal (e.g., using fiber optic cables), inductive signal (e.g., using suitable conductive coils), or other suitable signal type.

In some embodiments, the control signal of step **3514** may be received by one or more of auxiliary systems **3320**, which may adjust a clearance gap, or other property, of piston engine **3340**. For example, as shown by step **3516**, the control signal of step **3514** may be received by cooling/heating system **3322**, which may adjust a temperature of a coolant or heating fluid. Cooling/heating system **3322** may include a thermostat or other temperature regulating device, which may adjust a coolant or heating fluid temperature provided to piston engine **3340** at step **3516** according to the control signal. In a

further example, step **3516** may include cooling/heating system **3322** adjusting one or more throttle properties to control a temperature of a throttled fluid. In a further example, as shown by step **3518**, the control signal of step **3514** may be received by cooling/heating system **3322**, which may adjust a flow rate of a coolant or heating fluid. Cooling/heating system **3322** may include a flow regulator (e.g., a metering valve or orifice), which may adjust a flow rate of coolant or heating fluid provided to piston engine **3340** at step **3518** according to the control signal. In a further example, step **3518** may include cooling/heating system **3322** adjusting one or more throttle properties to control a flow rate of a throttled fluid. In a further example, as shown by step **3520**, the control signal of step **3514** may be received by cooling/heating system **3322**, which may adjust a flow route of a coolant or heating fluid at step **3520**. Cooling/heating system **3322** may include one or more valves, throttles, or other flow control devices which may direct and control a flow rate of coolant or heating fluid provided to piston engine **3340** to and/or from one or more fluid passages, according to the control signal. In a further example, as shown by step **3522**, the control signal of step **3514** may be received by pressure control system **3324**, which may adjust one or more properties of a heat pipe at step **3522**. Pressure control system **3324** may include one or more valves and a fluid reservoir, and may adjust the pressure of fluid within a heat pipe of piston engine **3340** (e.g., by supplying or removing fluid from the heat pipe), according to the control signal. In a further example, as shown by step **3524**, the control signal of step **3514** may be received by pressure control system **3324**, which may adjust the pressure and/or flow of a liner fluid to a deformable cylinder liner of piston engine **3340**. Pressure control system **3324** may include one or more valves, pumps, and a fluid reservoir, and may adjust the pressure and/or flow rate of liner fluid, and

accordingly the deformation of the deformable cylinder liner of piston engine **3340** (e.g., by increasing or decreasing pressure in the liner passages) at step **3524**, according to the control signal. In a further example, as shown by step **3526**,  
5 the control signal of step **3514** may be received by other system **3328**, which may adjust one or more properties of piston engine **3340**. Other system **3328** may include any suitable components to achieve the adjustment of the one or more properties of piston engine **3340** at step **3526**, based at least  
10 in part on the control signal. For example, other system **3328** may include power electronics configured to provide electric power to one or more electric resistance heaters embedded in piston engine **3340**, and step **3526** may include adjusting voltage, current, or both supplied to the electric resistance  
15 heaters .

Any of the illustrative steps of flow diagrams **3400-3500** may be combined with other steps, omitted, rearranged, or otherwise altered in accordance with the present disclosure.

The foregoing is merely illustrative of the principles of  
20 this disclosure and various modifications may be made by those skilled in the art without departing from the scope of this disclosure. The above described embodiments are presented for purposes of illustration and not of limitation. The present disclosure also can take many forms other than those  
25 explicitly described herein. Accordingly, it is emphasized that this disclosure is not limited to the explicitly disclosed methods, systems, and apparatuses, but is intended to include variations to and modifications thereof, which are within the spirit of the following claims.

30

What is claimed is:

- 5 1. An assembly configured to translate along an axis of a  
bore of a cylinder of a piston engine, the assembly  
comprising :
- a piston face configured to contact a section of the  
cylinder, the section capable of containing a fluid; and
- 10                   at least one heat pipe in direct or indirect thermal  
contact with the piston face.
2. The assembly of claim 1, wherein a first portion of the  
at least one heat pipe and the piston face are configured to  
15 transfer heat between each other, and wherein a second portion  
of the at least one heat pipe and a heat receptacle are  
configured to transfer heat between each other.
3. The assembly of claim 2, wherein the heat receptacle  
20 comprises at least one of a bearing element, a clearance gap,  
a surface of the bore of the cylinder, and a piston rod.
4. The assembly of claim 1, further comprising a fluid  
contained within the at least one heat pipe.
- 25 5. The assembly of claim 4, wherein the fluid comprises a  
fluid capable of undergoing a liquid/vapor phase transition  
during operation of the piston engine.
- 30 6. The assembly of claim 4, wherein the fluid is selected  
from the group consisting of water, ethanol, ammonia, sodium,  
and any combination thereof.

7. The assembly of claim 4, wherein the at least one heat pipe is capable of being sealed to maintain a constant volume of the fluid contained within the at least one heat pipe.

5 8. The assembly of claim 1, further comprising one or more fluid ports coupled to the at least one heat pipe, wherein the fluid ports allow the fluid to be supplied to or removed from the at least one heat pipe.

10 9. The assembly of claim 1, wherein the at least one heat pipe comprises at least one material selected from the group consisting of copper, aluminum, steel, stainless steel, a nickel alloy, and bronze.

15 10. The assembly of claim 1, further comprising a piston frame, wherein the piston face is rigidly connected to the piston frame, and wherein the at least one heat pipe is rigidly connected to the piston frame.

20 11. The assembly of claim 1, wherein the section comprises at least one of a combustion section and a gas driver section.

12. The assembly of claim 1, further comprising at least one bearing element configured to provide a flow of a bearing  
25 fluid into a clearance gap formed between the assembly and the cylinder .

13. The assembly of claim 12, wherein the bearing element is affixed to the assembly, and wherein the assembly further  
30 comprises a feed passage configured to receive the bearing fluid from a fluid source and to provide the bearing fluid to the bearing element.

14. The assembly of claim 1, wherein the fluid contained in the section comprises a gas, and wherein blow-by gas from the section flows axially away from the section through a clearance gap between the assembly and the cylinder, and  
5 wherein the piston comprises a feature or a component that provides self-centering using a flow of the blow-by gas.

15. The assembly of claim 1, wherein the assembly is configured for oil-less operation.

10

16. A cylinder of a piston engine, the cylinder comprising:  
a bore having an axis, the bore configured to contain a piston that moves along the axis; and  
at least one heat pipe in direct or indirect thermal  
15 contact with the bore.

17. The cylinder of claim 16, wherein a first portion of the at least one heat pipe and the bore are configured to transfer heat between each other, and wherein a second portion of the  
20 at least one heat pipe and a heat receptacle are configured to transfer heat between each other.

18. The cylinder of claim 17, further comprising one or more coolant passages, wherein the heat receptacle comprises a  
25 coolant in the one or more coolant passages.

19. The cylinder of claim 16, further comprising a fluid contained within the at least one heat pipe.

30 20. The cylinder of claim 19, wherein the fluid comprises a fluid capable of undergoing a liquid/vapor phase transition during operation of the piston engine.

21. The cylinder of claim 19, wherein the fluid is selected from the group consisting of water, ethanol, ammonia, sodium, and a combination thereof.

5 22. The cylinder of claim 19, wherein the at least one heat pipe is capable of being sealed to maintain a constant volume of the fluid contained within the at least one heat pipe.

10 23. The cylinder of claim 16, further comprising one or more fluid ports coupled to the at least one heat pipe, wherein the fluid ports allow the fluid to be supplied to or removed from the at least one heat pipe.

15 24. The cylinder of claim 16, wherein the at least one heat pipe comprises at least one material selected from the group consisting of copper, aluminum, steel, stainless steel, a nickel alloy, and bronze.

20 25. The cylinder of claim 16, wherein the at least one heat pipe is arranged annularly about a center axis of the bore, at a diameter larger than the bore diameter.

25 26. The cylinder of claim 16, further comprising at least one bearing element configured to provide a flow of a bearing fluid into a clearance gap formed between the piston and the cylinder .

30 27. The cylinder of claim 26, wherein the bearing element is affixed to the cylinder, and wherein the cylinder further comprises a feed passage configured to receive the bearing fluid from a fluid source and to provide the bearing fluid to the bearing element.

28. The cylinder of claim 26, wherein the bearing element is affixed to the piston, and wherein the piston further comprises a feed passage configured to receive the bearing fluid from a fluid source and to provide the bearing fluid to  
5 the bearing element.

29. The cylinder of claim 16, further comprising a section capable of containing a fluid comprising a gas, wherein blow-by gas from the section flows axially away from the section  
10 through a clearance gap between the piston and the cylinder, and wherein the piston comprises a feature or a component that provides self-centering using a flow of the blow-by gas.

30. The cylinder of claim 16, wherein the cylinder is  
15 configured for oil-less operation.

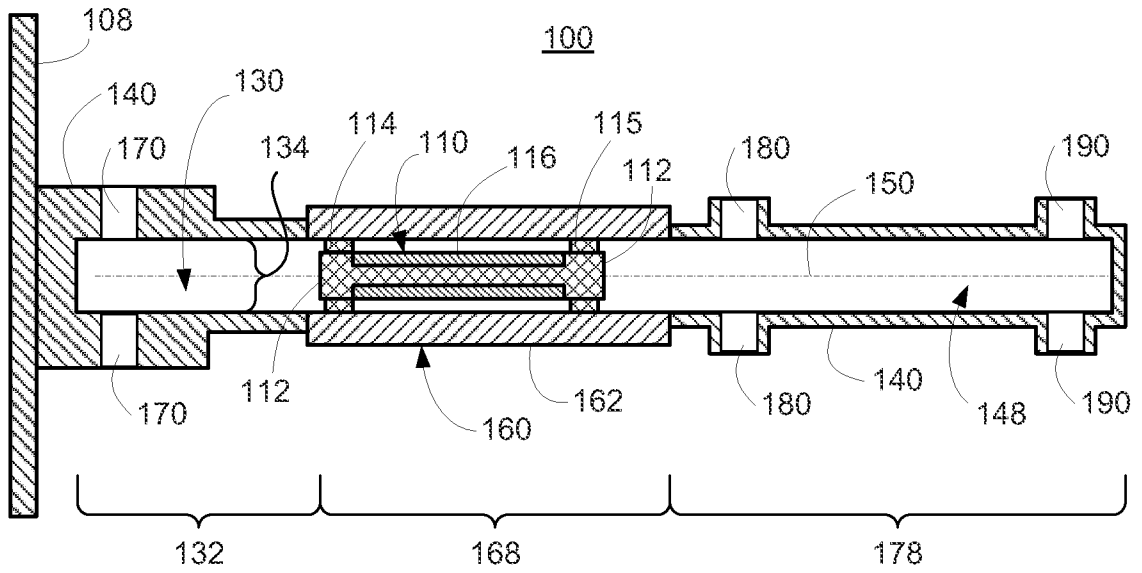

FIG. 1

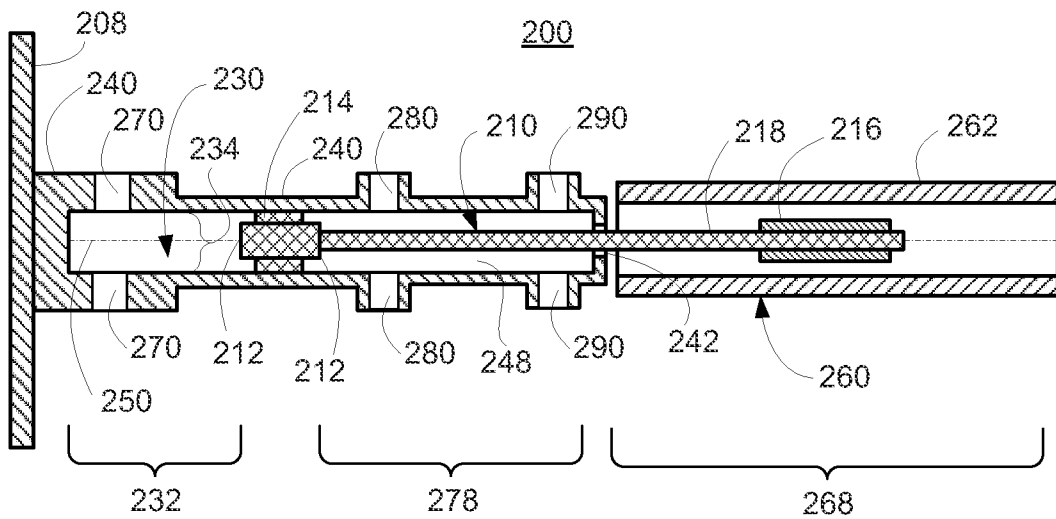

FIG. 2

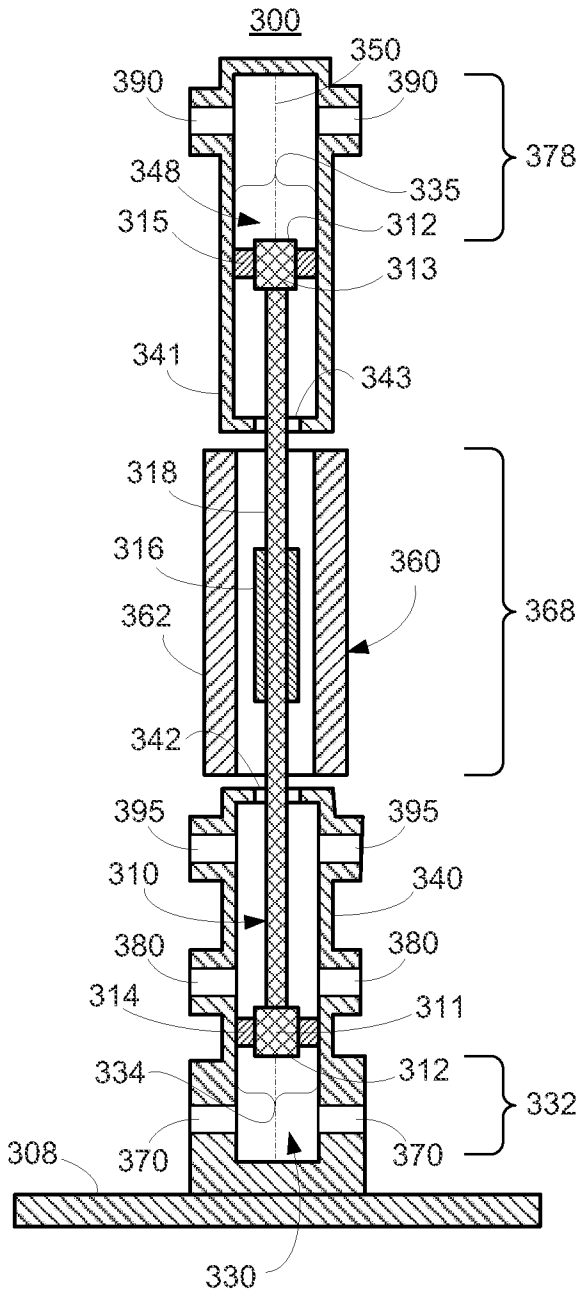

FIG. 3

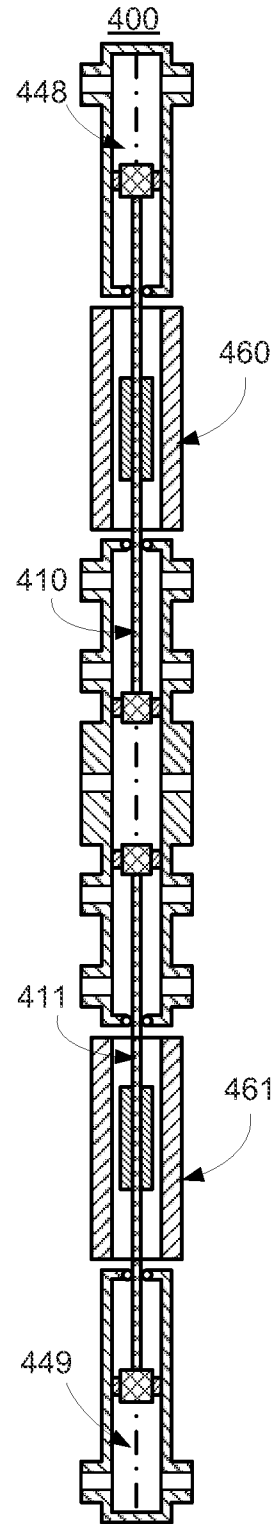

FIG. 4

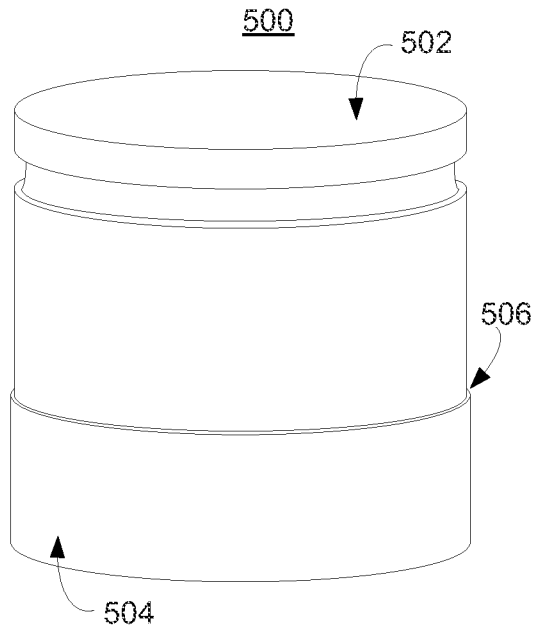

FIG. 5

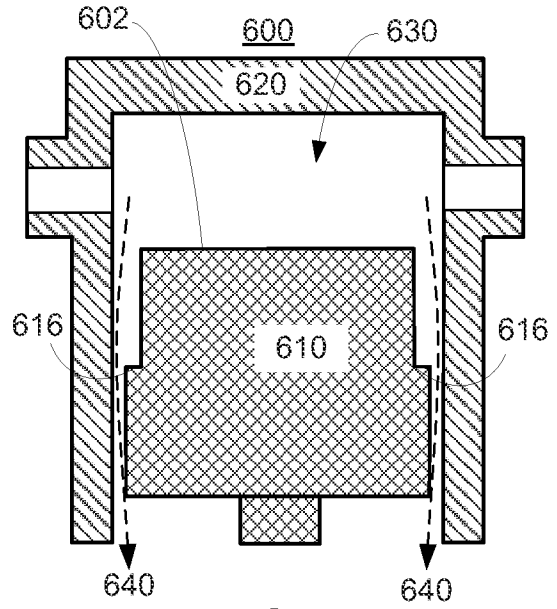

FIG. 6

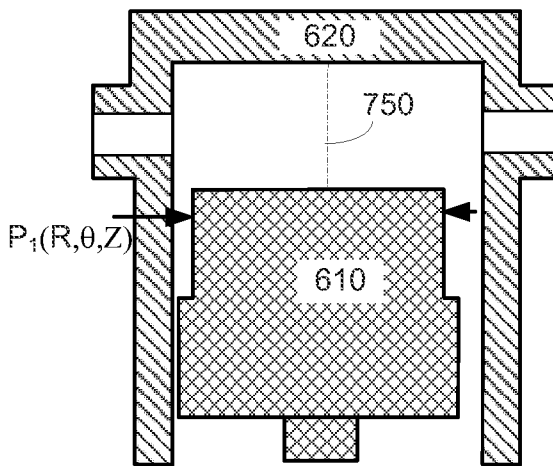

FIG. 7

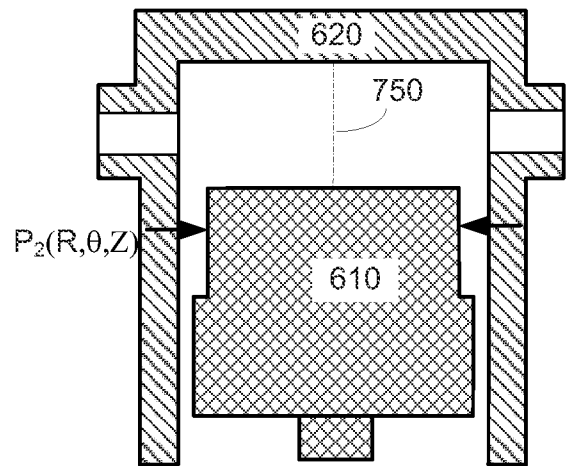

FIG. 8

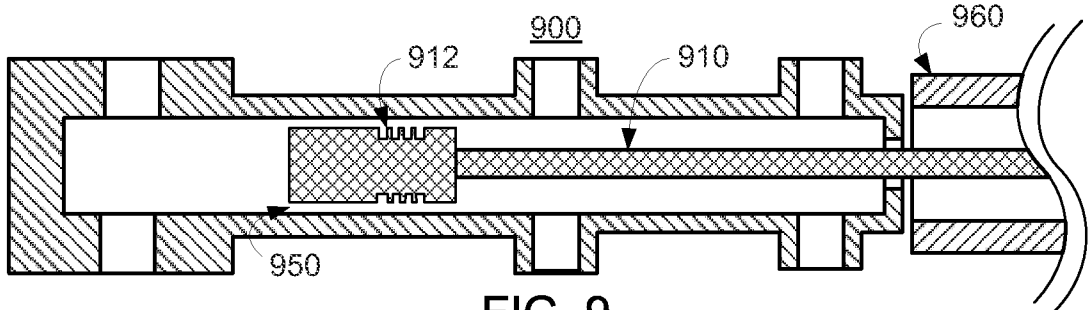

FIG. 9

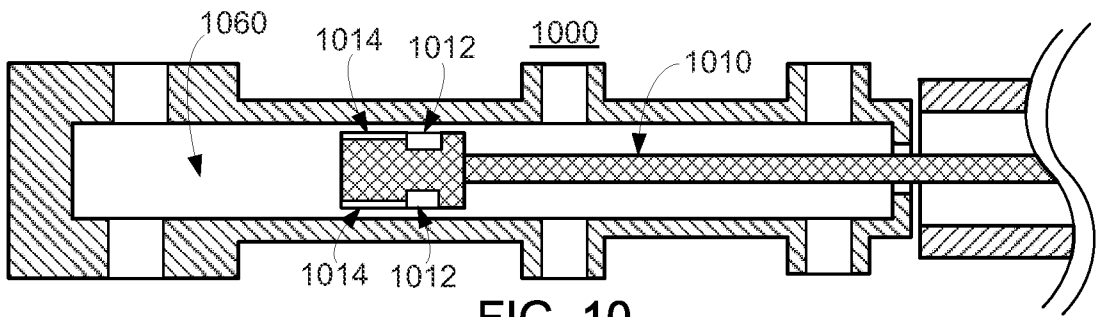

FIG. 10

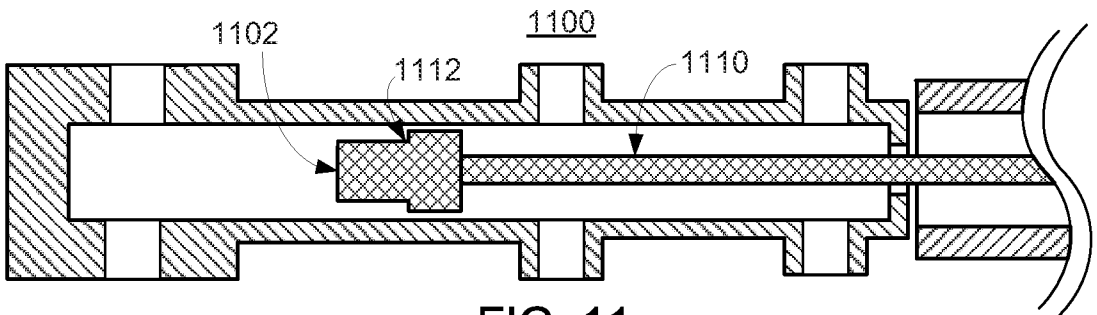

FIG. 11

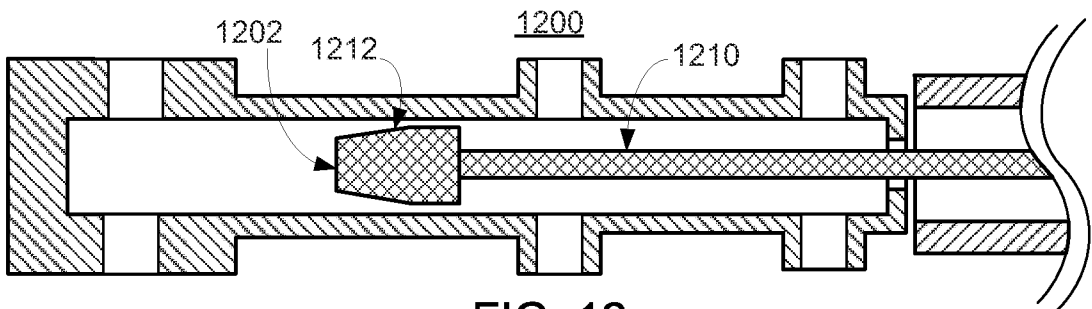

FIG. 12

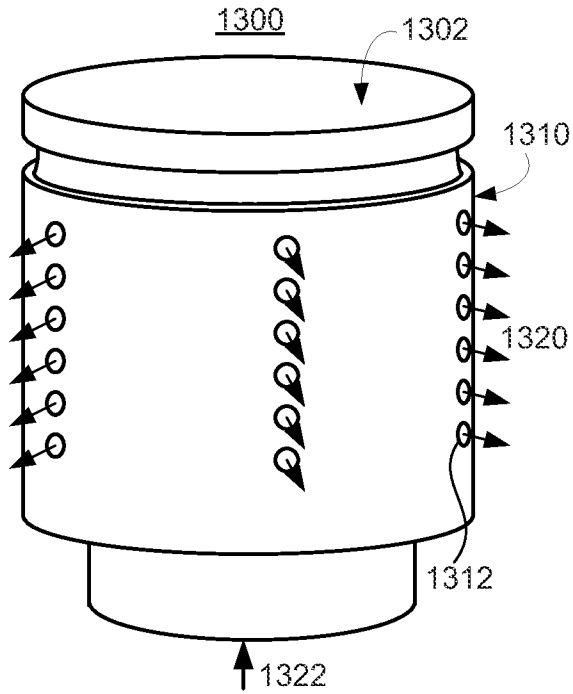

FIG. 13

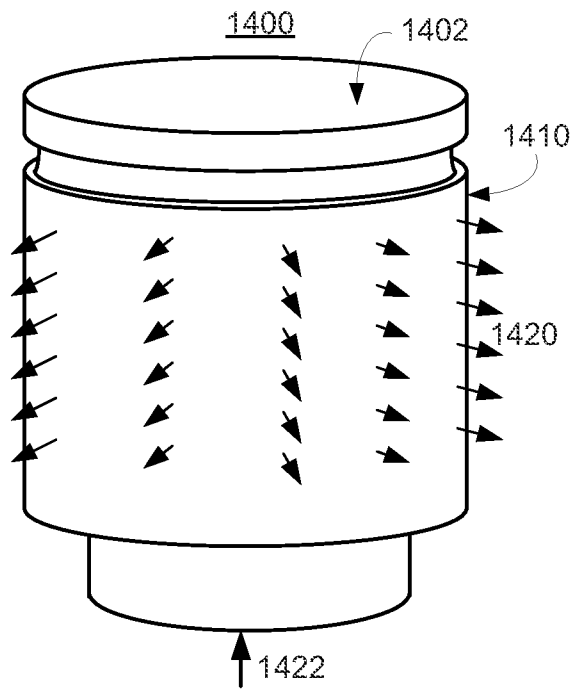

FIG. 14

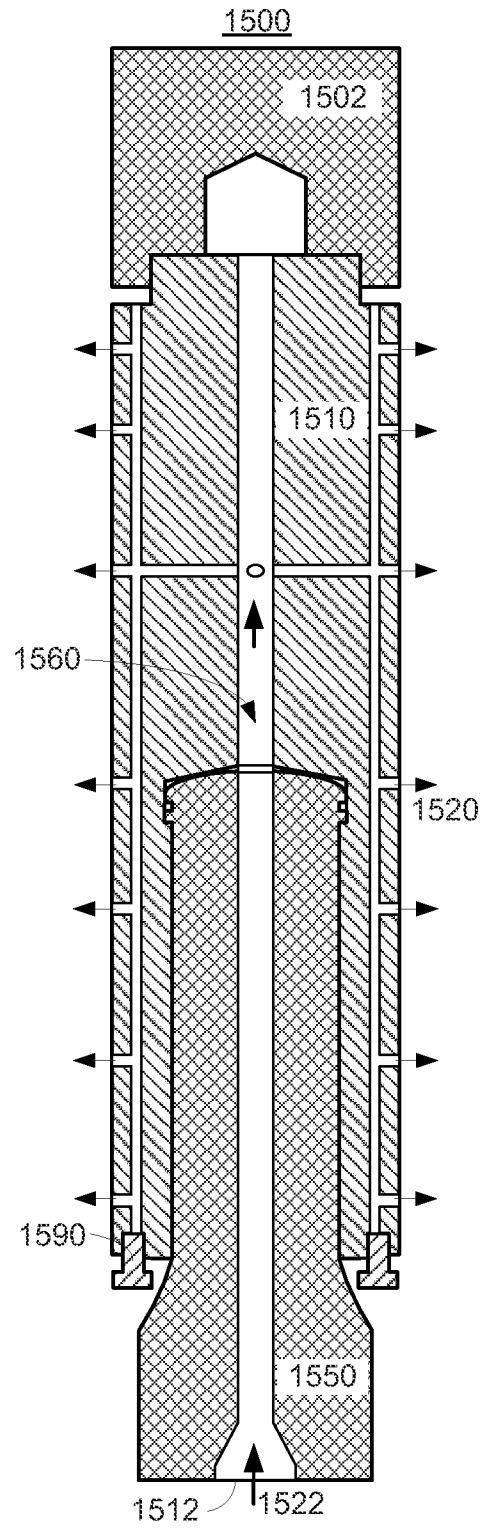

FIG. 15

6/16

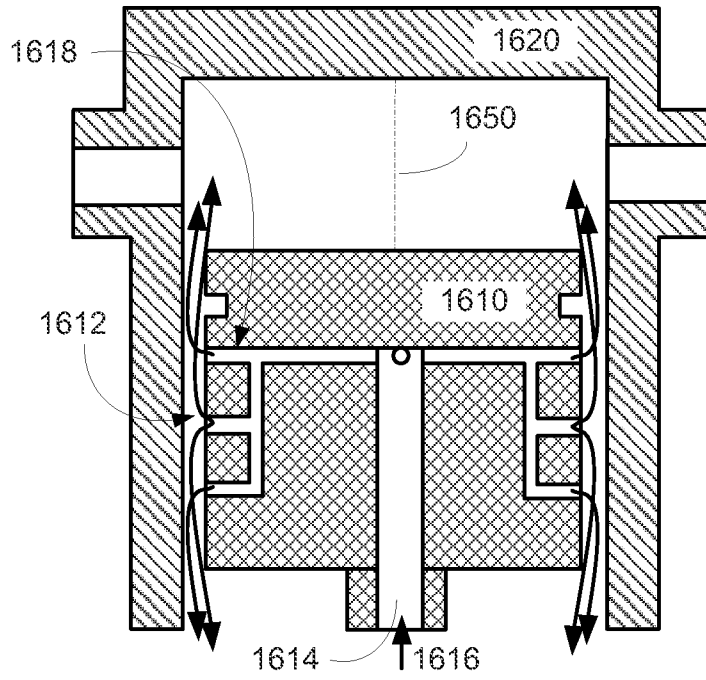

FIG. 16

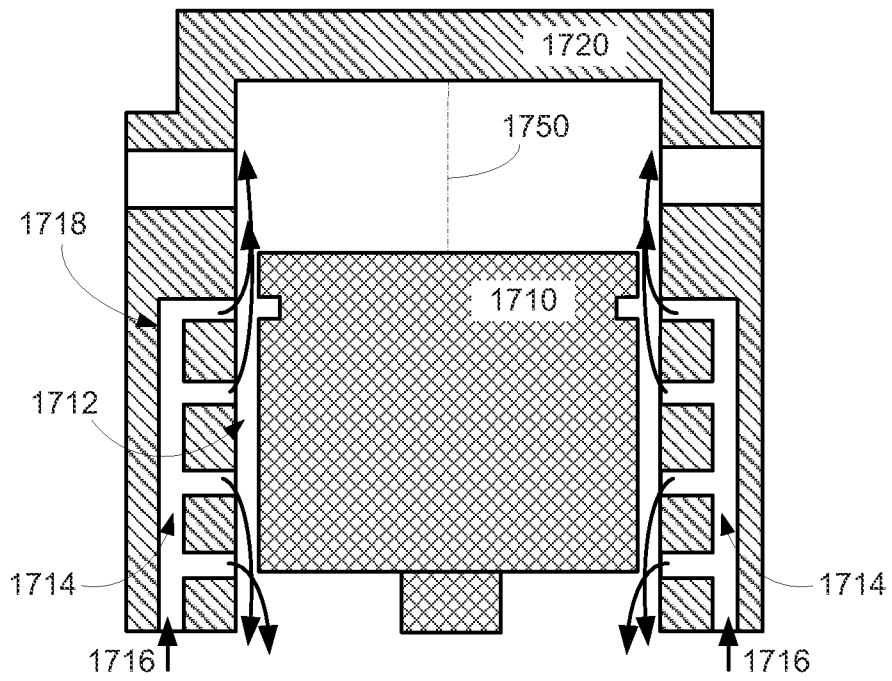

FIG. 17

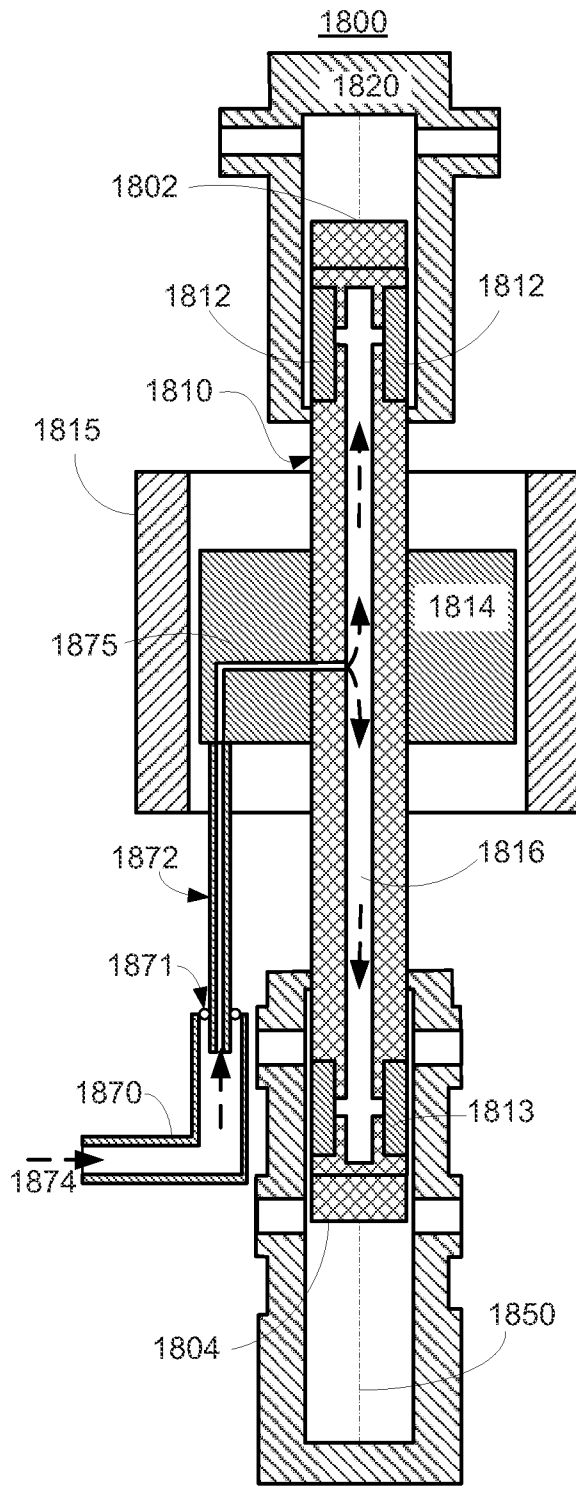

FIG. 18

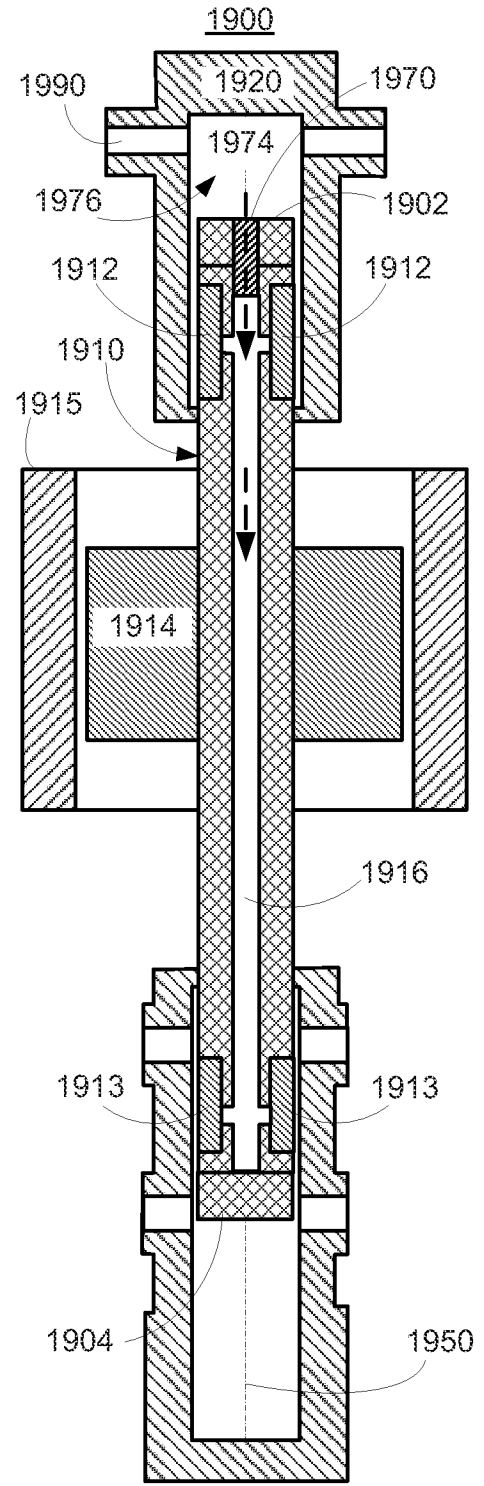

FIG. 19

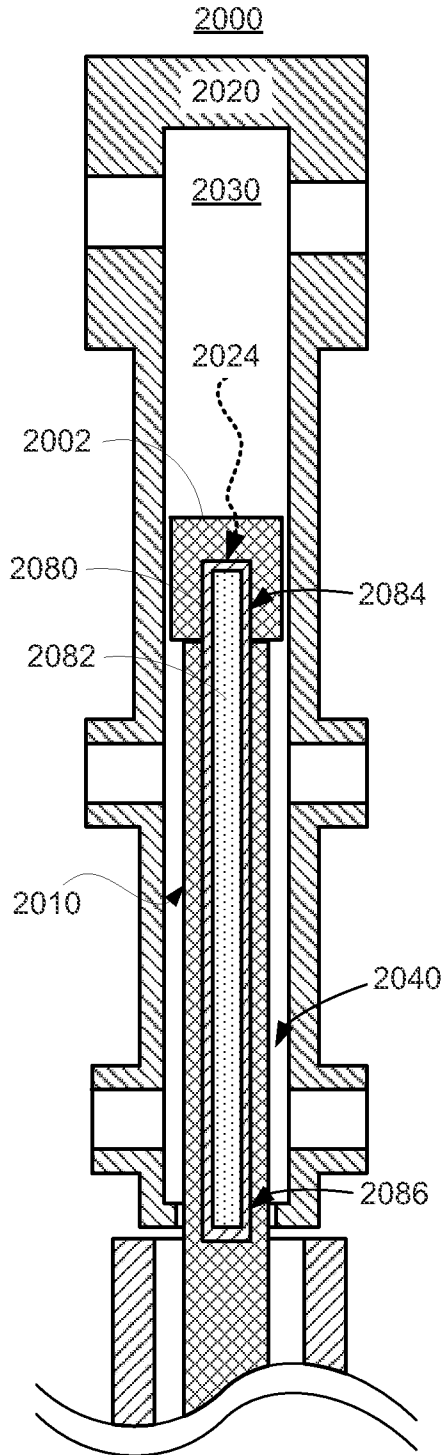

FIG. 20

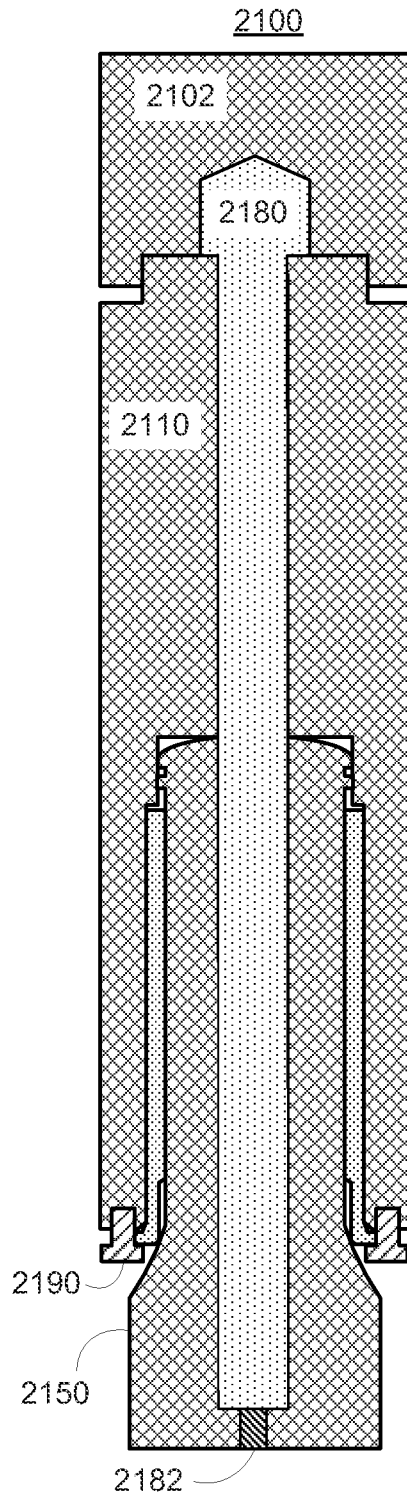

FIG. 21

9/16

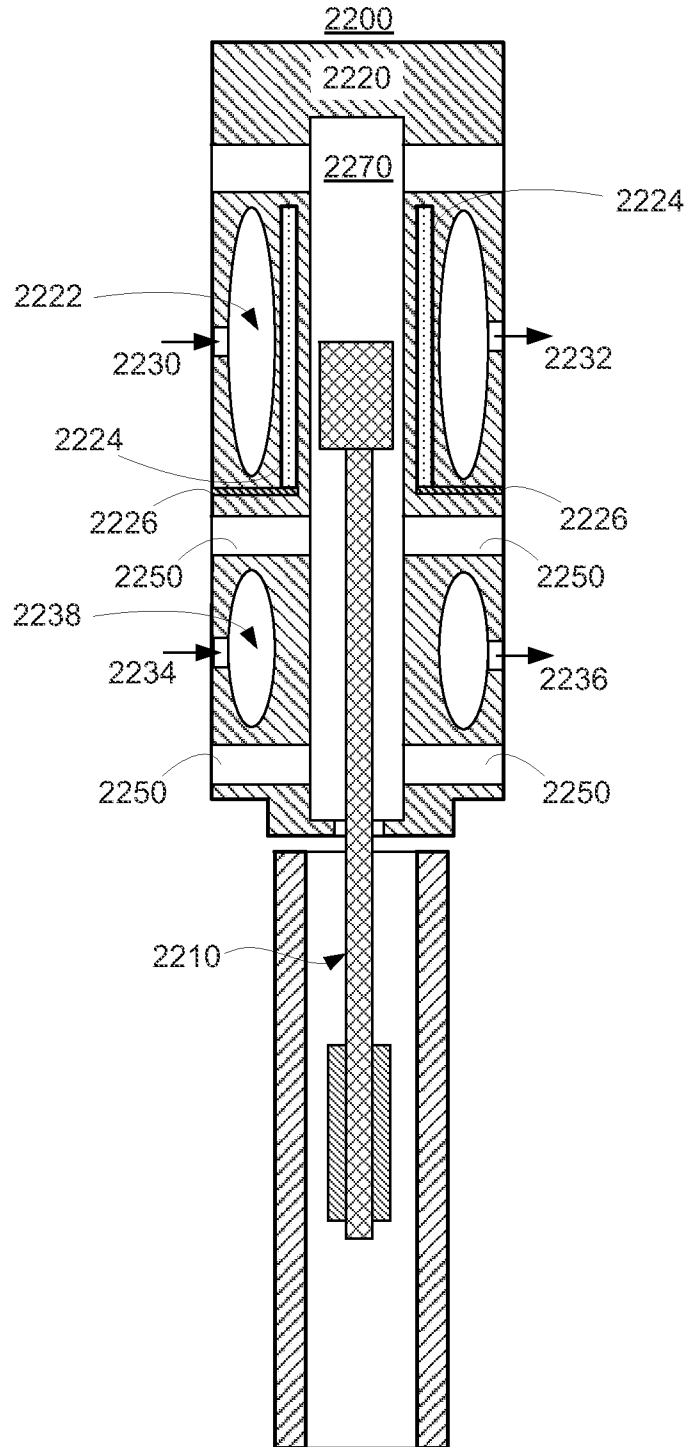

FIG. 22

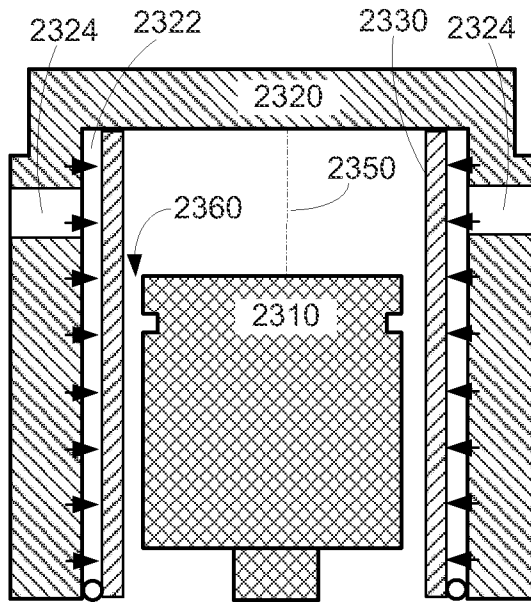

FIG. 23

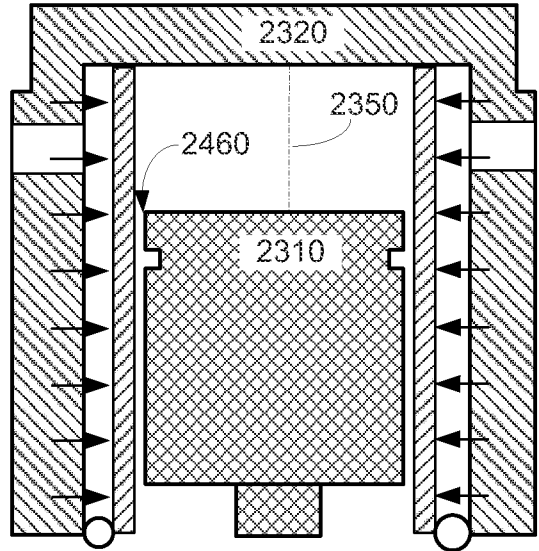

FIG. 24

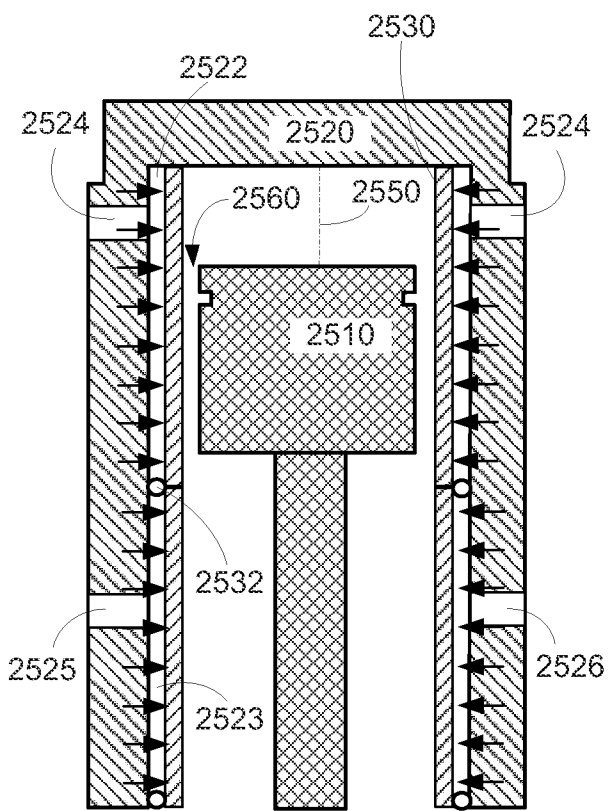

FIG. 25

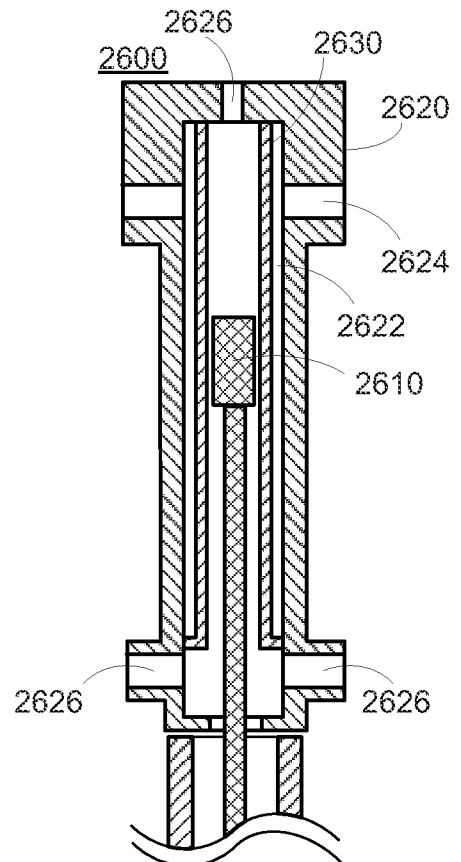

FIG. 26

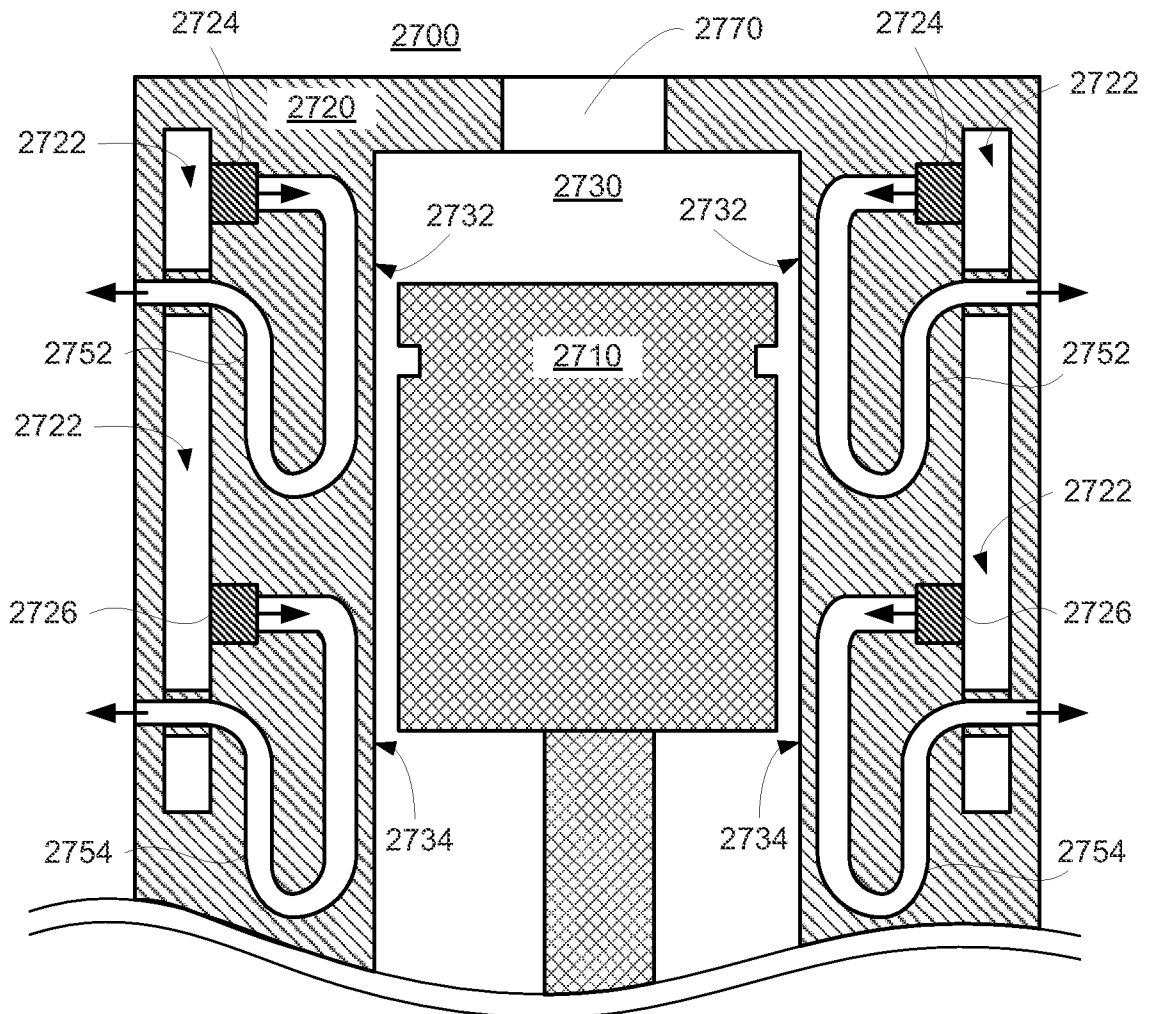

FIG. 27

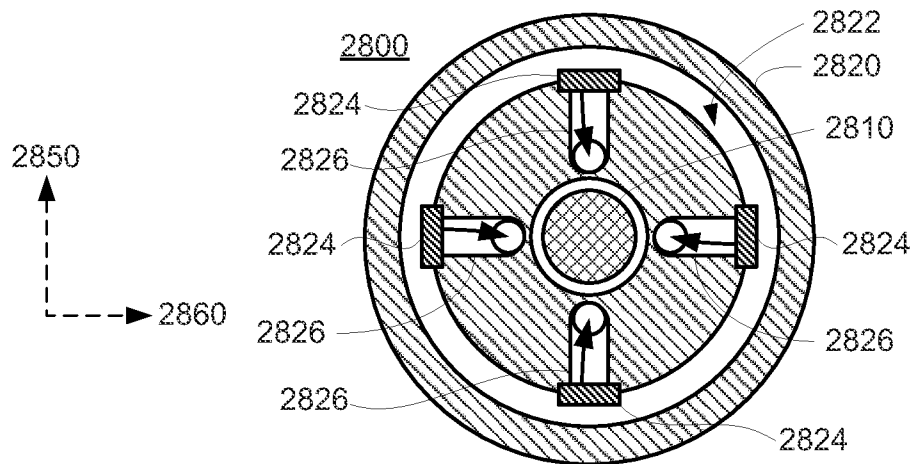

FIG. 28

12/16

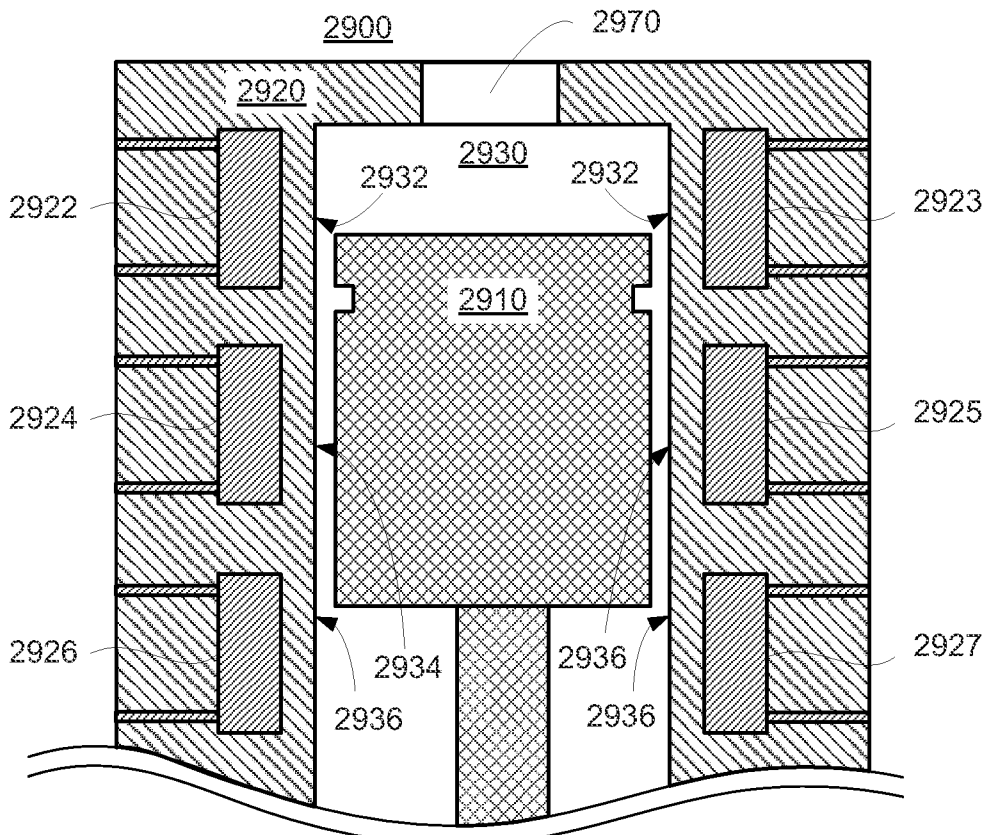

FIG. 29

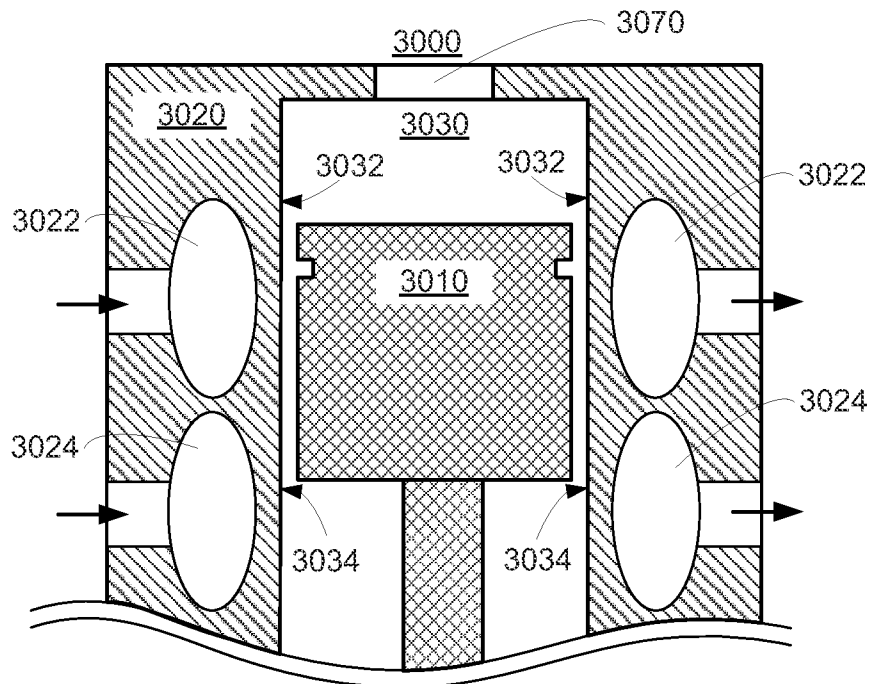

FIG. 30

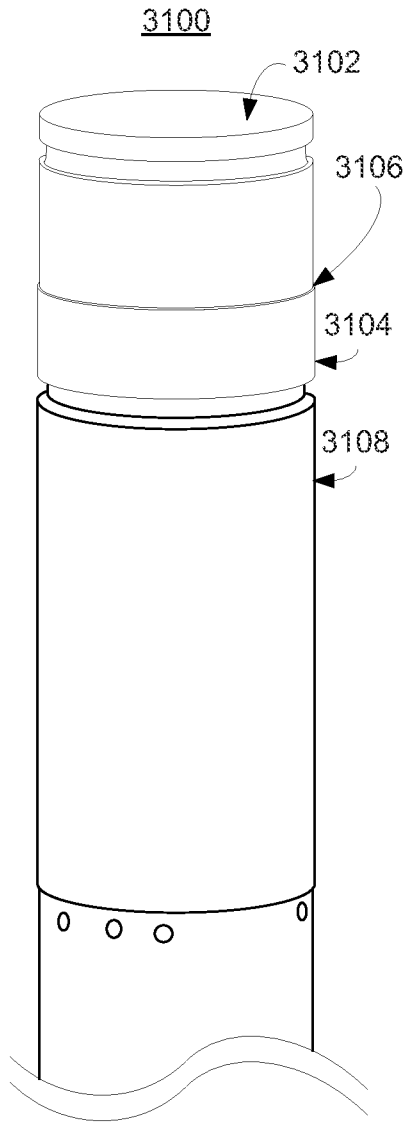

FIG. 31

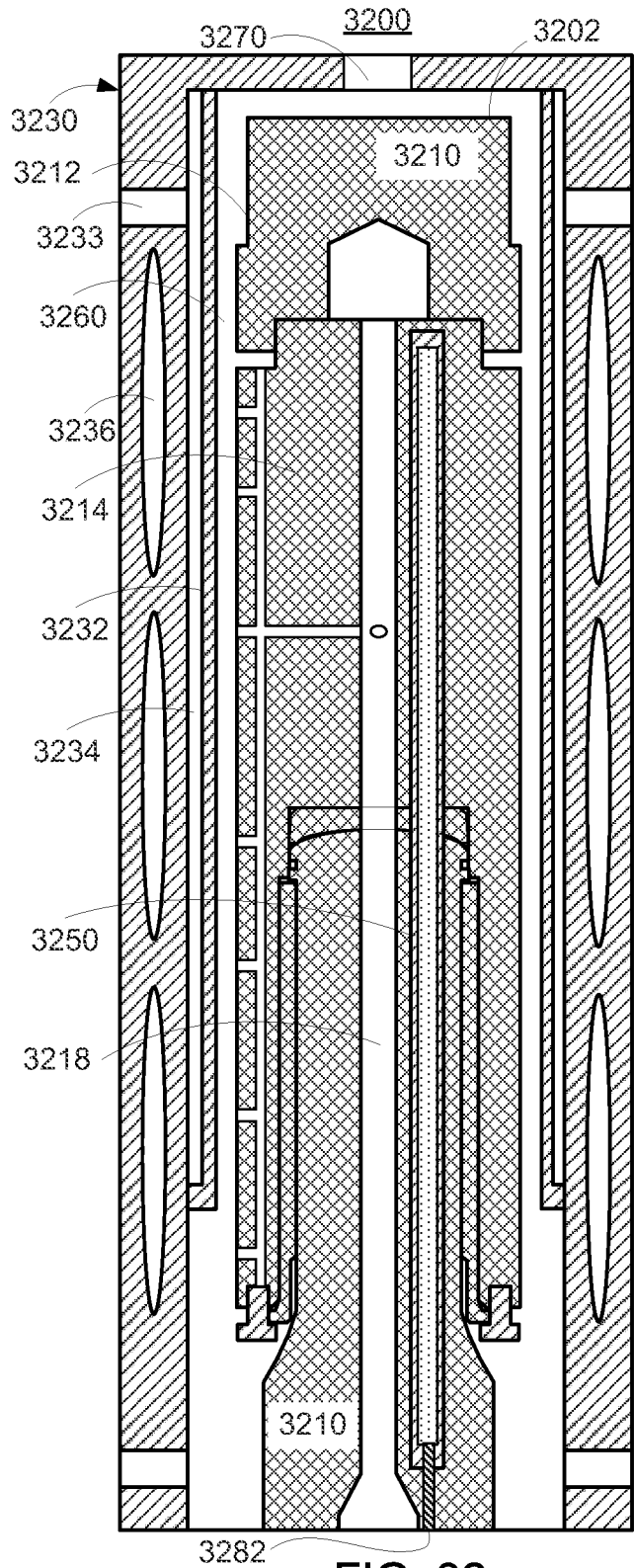

FIG. 32

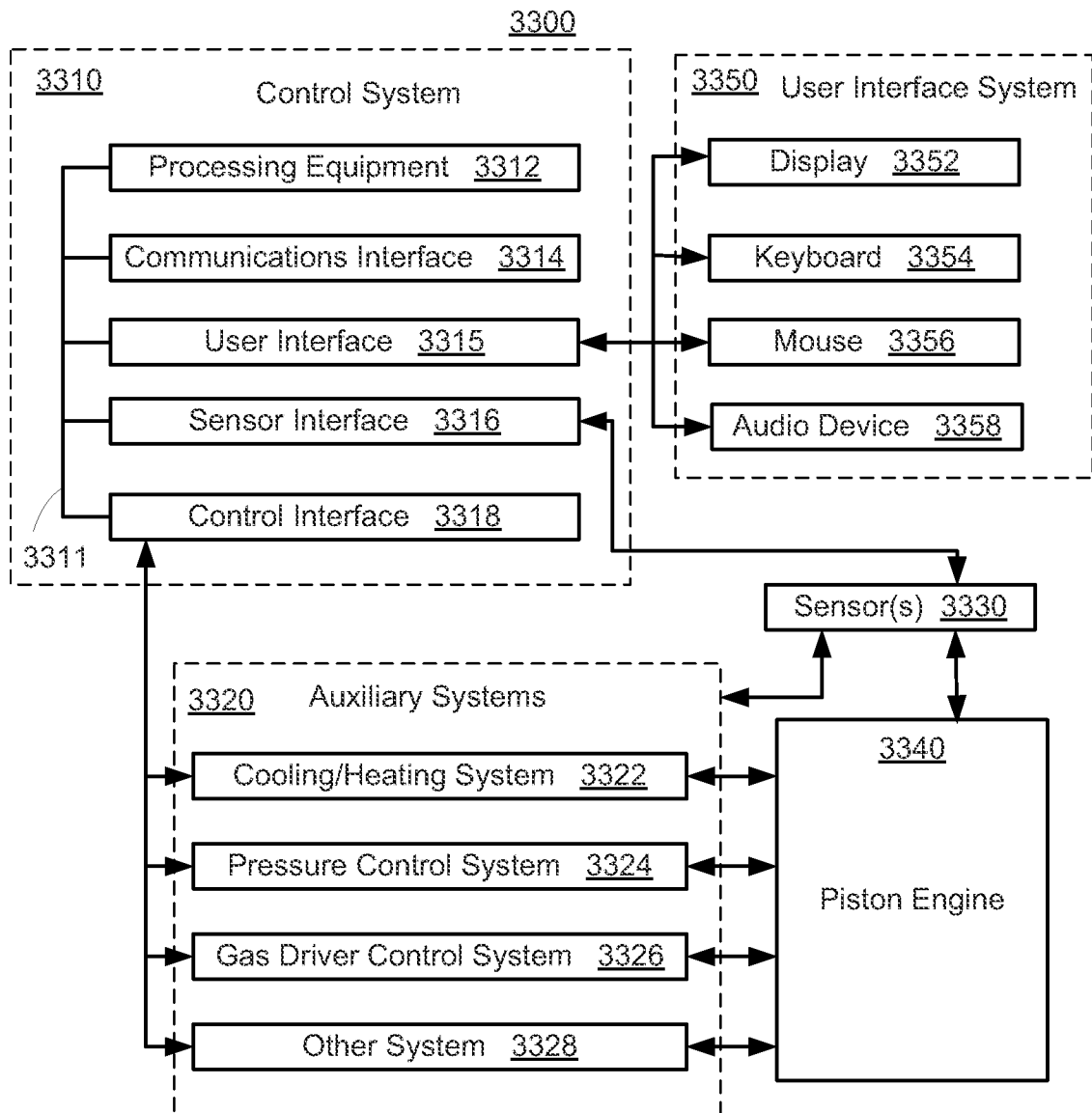

FIG. 33

15/16

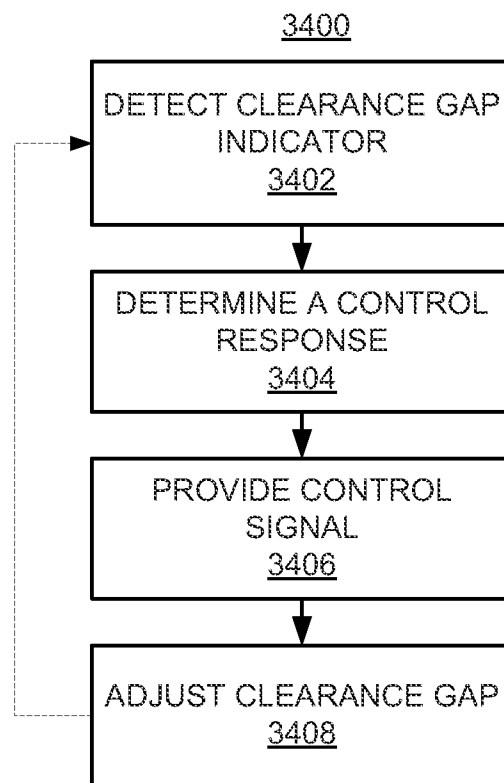

FIG. 34

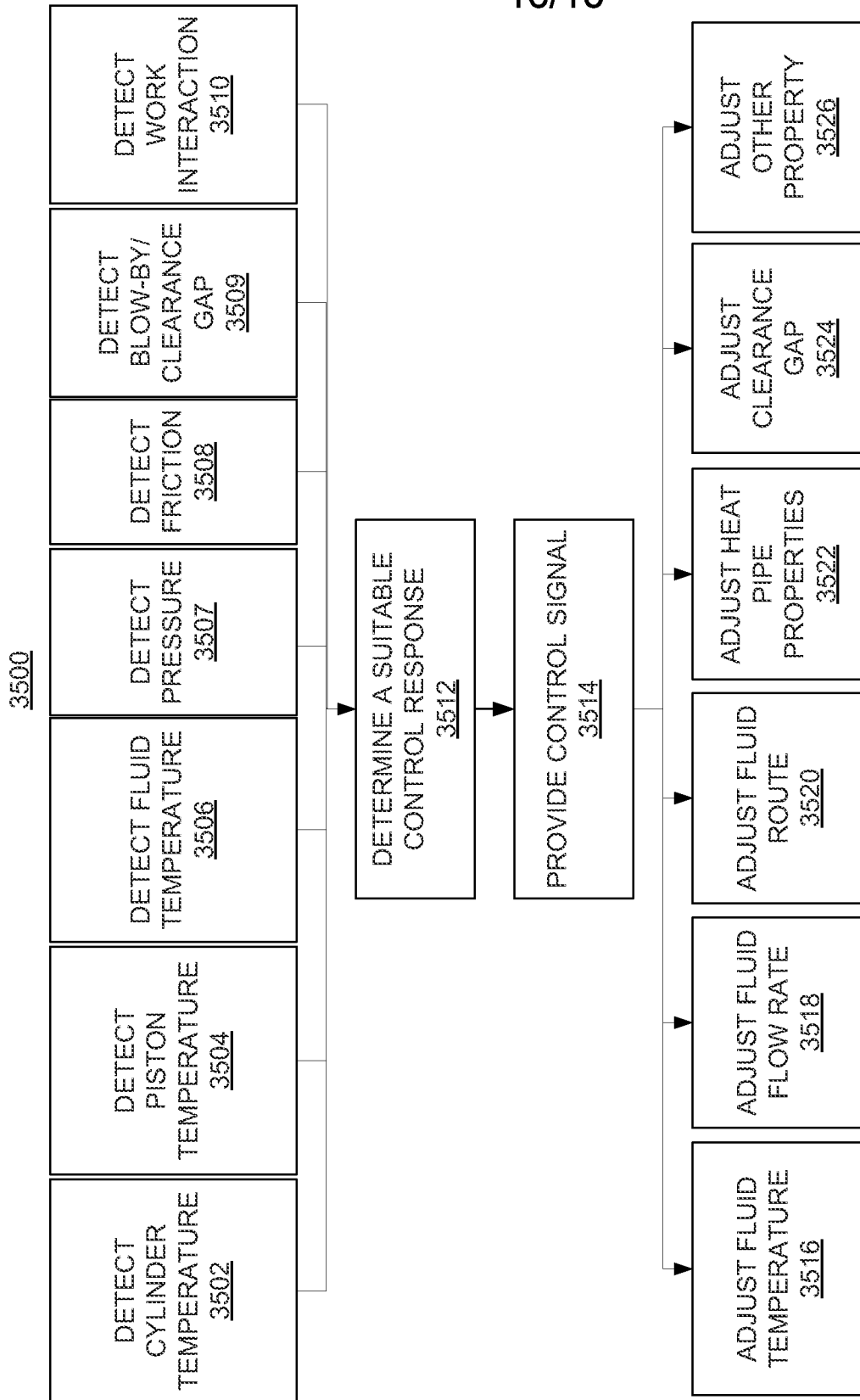

FIG. 35

**INTERNATIONAL SEARCH REPORT**

International application No  
PCT/US2012/071524

A. CLASSIFICATION OF SUBJECT MATTER  
 INV. F01B23/10 F16J1/08 F16J10/04 F16C29/02 F02B63/04  
 ADD.  
 According to International Patent Classification (IPC) or to both national classification and IPC

B. FIELDS SEARCHED  
 Minimum documentation searched (classification system followed by classification symbols)  
 F01B F16J F16C F02B

Documentation searched other than minimum documentation to the extent that such documents are included in the fields searched

Electronic data base consulted during the international search (name of data base and, where practicable, search terms used)  
 EPO-Internal , WPI Data

C. DOCUMENTS CONSIDERED TO BE RELEVANT

Category*	Citation of document, with indication, where appropriate, of the relevant passages	Relevant to claim No.
Y	GB 1 125 524 A (BRITISH OXYGEN CO LTD) 28 August 1968 (1968-08-28) page 2, line 80 - line 88 -----	1-30
Y	US 4 644 851 A (YOUNG NI ELS O [US] ) 24 February 1987 (1987-02-24) abstract -----	1-30
Y	EP 0 330 326 A2 ( FORD MOTOR CO [GB] ; FORD WERKE AG [DE] ; FORD FRANCE [FR] ) 30 August 1989 (1989-08-30) figure 2 -----	1-30
Y	Wo 02/44593 AI (OSKAR F VATTEROTT INC [US] ; VATTEROTT GLADYS EF [US] ; VATTEROTT BRYAN) 6 June 2002 (2002-06-06) abstract -----	1-30
	-/- .	

Further documents are listed in the continuation of Box C.

See patent family annex.

\* Special categories of cited documents :

"A" document defining the general state of the art which is not considered to be of particular relevance	"T" later document published after the international filing date or priority date and not in conflict with the application but cited to understand the principle or theory underlying the invention
"E" earlier application or patent but published on or after the international filing date	"X" document of particular relevance; the claimed invention cannot be considered novel or cannot be considered to involve an inventive step when the document is taken alone
"L" document which may throw doubts on priority claim(s) or which is cited to establish the publication date of another citation or other special reason (as specified)	"Y" document of particular relevance; the claimed invention cannot be considered to involve an inventive step when the document is combined with one or more other such documents, such combination being obvious to a person skilled in the art
"O" document referring to an oral disclosure, use, exhibition or other means	
"P" document published prior to the international filing date but later than the priority date claimed	"&" document member of the same patent family

Date of the actual completion of the international search  16 May 2013	Date of mailing of the international search report  04/06/2013
--	--

Name and mailing address of the ISA/ European Patent Office, P.B. 5818 Patentlaan 2 NL - 2280 HV Rijswijk Tel. (+31-70) 340-2040, Fax: (+31-70) 340-3016	Authorized officer  Yates , John
--	--

## INTERNATIONAL SEARCH REPORT

International application No  
PCT/US2012/071524

C(Continuation). DOCUMENTS CONSIDERED TO BE RELEVANT		
Category*	Citation of document, with indication, where appropriate, of the relevant passages	Relevant to claim No.
Y	US 7 438 027 B1 (HINDERKS MITJA V [US]) 21 October 2008 (2008-10-21) column 21, line 32 - line 33 column 22, line 54 - line 63 -----	1-30
Y	EP 2 357 348 A1 (TOYOTA MOTOR CO LTD [JP]) 17 August 2011 (2011-08-17) paragraph [0025] - paragraph [0027] -----	1-30
X	US 3 956 895 A (NOBLE JACK E ET AL) 18 May 1976 (1976-05-18) abstract -----	1-30
X	JP S59 101565 A (HINO MOTORS LTD) 12 June 1984 (1984-06-12) abstract -----	1-30
X	US 5 454 351 A (CAO YIDING [US] ET AL) 3 October 1995 (1995-10-03) abstract -----	1-30
X	US 6 349 681 B1 (LI CHIN-HSIU [US]) 26 February 2002 (2002-02-26) abstract -----	1-30
X	DE 20 2005 018178 U1 (DOLMAR GMBH [DE]) 23 February 2006 (2006-02-23) abstract -----	1-30
X	CN 101 363 353 A (SHANGHAI LANANG ELECTRONIC TEC [CN]) 11 February 2009 (2009-02-11) claim 1; figure 1 -----	1-30
X	US 2010/218496 A1 (MILES MARK W [US]) 2 September 2010 (2010-09-02) paragraph [0087] - paragraph [0088] -----	1-30

# INTERNATIONAL SEARCH REPORT

Information on patent family members

International application No <b>PCT/US2012/071524</b>
--

Patent document cited in search report	Publication date	Patent family member(s)	Publication date
GB 1125524	A	28-08-1968	DE 1625923 A1 06-08-1970
			GB 1125524 A 28-08-1968
			NL 6710705 A 05-02-1968
			US 3538815 A 10-11-1970
-----			
US 4644851	A	24-02-1987	NONE
-----			
EP 0330326	A2	30-08-1989	AU 3018389 A 24-08-1989
			CA 1321330 C 17-08-1993
			DE 68914706 D1 26-05-1994
			DE 68914706 T2 04-08-1994
			EP 0330326 A2 30-08-1989
			US 4846051 A 11-07-1989
-----			
WO 0244593	A1	06-06-2002	AU 2706302 A 11-06-2002
			CA 2436938 A1 06-06-2002
			EP 1350046 A1 08-10-2003
			US 2002100363 A1 01-08-2002
			WO 0244593 A1 06-06-2002
-----			
US 7438027	B1	21-10-2008	NONE
-----			
EP 2357348	A1	17-08-2011	CN 102245888 A 16-11-2011
			EP 2357348 A1 17-08-2011
			JP 5110173 B2 26-12-2012
			US 2011197755 A1 18-08-2011
			WO 2010067728 A1 17-06-2010
-----			
US 3956895	A	18-05-1976	NONE
-----			
JP S59101565	A	12-06-1984	JP H0115693 B2 20-03-1989
			JP S59101565 A 12-06-1984
-----			
US 5454351	A	03-10-1995	NONE
-----			
US 6349681	B1	26-02-2002	NONE
-----			
DE 202005018178	U1	23-02-2006	NONE
-----			
CN 101363353	A	11-02-2009	NONE
-----			
US 2010218496	A1	02-09-2010	US 2010218496 A1 02-09-2010
			WO 2010101682 A1 10-09-2010
-----			

INTERNATIONAL SEARCH REPORT

International application No.  
PCT/US2012/071524

Box No. II Observations where certain claims were found unsearchable (Continuation of item 2 of first sheet)

This international search report has not been established in respect of certain claims under Article 17(2)(a) for the following reasons:

1.  Claims Nos.:  
because they relate to subject matter not required to be searched by this Authority, namely:
  
2.  claims nos.: 1-30 (partially)  
because they relate to parts of the international application that do not comply with the prescribed requirements to such an extent that no meaningful international search can be carried out, specifically:  
  
see FURTHER INFORMATION sheet PCT/ISA/210
  
3.  Claims Nos.:  
because they are dependent claims and are not drafted in accordance with the second and third sentences of Rule 6.4(a).

Box No. III Observations where unity of invention is lacking (Continuation of item 3 of first sheet)

This International Searching Authority found multiple inventions in this international application, as follows:

1.  As all required additional search fees were timely paid by the applicant, this international search report covers all searchable claims.
  
2.  As all searchable claims could be searched without effort justifying an additional fees, this Authority did not invite payment of additional fees.
  
3.  As only some of the required additional search fees were timely paid by the applicant, this international search report covers only those claims for which fees were paid, specifically claims Nos. :
  
4.  No required additional search fees were timely paid by the applicant. Consequently, this international search report is restricted to the invention first mentioned in the claims; it is covered by claims Nos. :

Remark on Protest

- The additional search fees were accompanied by the applicant's protest and, where applicable, the payment of a protest fee.
- The additional search fees were accompanied by the applicant's protest but the applicable protest fee was not paid within the time limit specified in the invitation.
- No protest accompanied the payment of additional search fees.

## FURTHER INFORMATION CONTINUED FROM PCT/ISA/ 210

Continuation of Box 11.2

Claims Nos.: 1-30(partially)

It is a fundamental principle of the patent system that an applicant gets a patent in return for making the invention public. The usual practice in patents is for a development to be perceived as an invention and then an application to be filed aimed at this perceived invention. Of course, a certain amount of generalisation in the description of the invention is reasonable, but there are limits as to how far this can be carried. It can be reasonably expected that someone active in a particular technical field will have an overview of that field and will thus be in a position to realistically determine just how much generalisation is reasonable. The current application is one of a series of four - US2012 071 523; US2012 071 524, US2012 071 525 & US2012 071 526. Not in any one of the four applications, nor in all four taken together, is anything apparent which would point to a clearly perceived invention forming the basis of the application(s). It is clear that in some way piston-cylinder combinations are concerned and taking all things together it would seem we are basically looking at the bearing of the piston within the cylinder. Not all claims point that way, however; for example the current application makes no mention of the bearing clearance gap (i.e. the title of the application) in the independent claims. Other than this, there appears to be nothing more than a nebulous cloud listing features which may or may not have some sort of relevance for piston/cylinder combinations. The abstract of the application is symptomatic in this regard in that it includes the word "may" very often and also lists alternatives, but doesn't go so far as to in fact say what the invention actually "is". It would seem the abstract indeed accurately reflects the application. Theoretically the invention is presented in the independent claim. Looking at the present application in more detail, we note 2 independent claims (1 & 16). At first sight it would seem that one is aimed at the piston and the other at the cylinder, however even this is uncertain since both refer to direct or indirect thermal contact and thus state little more than the fact that a heat pipe should be present, without going so far as to say what the heat pipe should achieve. It is clear that the independent claims do not reflect a clearly perceived invention. Looking at the description for help, we note that the summary starts with a statement to the effect that "in some embodiments a piston engine may include a piston and cylinder assembly", thereby implying that not even these components are necessarily present, and on the first page of the summary there is no mention of heat pipes at all. It would thus seem that we are unlikely to readily get further clarity from the description. Under these circumstances no meaningful search based on the full scope included in the precise wording of the claims is possible, rather nothing more than a general overview of the use of heat pipes in piston/cylinder arrangements over the years can be presented.

The applicant's attention is drawn to the fact that claims relating to inventions in respect of which no international search report has been established need not be the subject of an international preliminary examination (Rule 66.1(e) PCT). The applicant is advised that the EPO policy when acting as an International Preliminary Examining Authority is

**FURTHER INFORMATION CONTINUED FROM PCT/ISA/ 210**

normally not to carry out a preliminary examination on matter which has not been searched. This is the case irrespective of whether or not the claims are amended following receipt of the search report or during any Chapter II procedure. If the application proceeds into the regional phase before the EPO, the applicant is reminded that a search may be carried out during examination before the EPO (see EPO Guidelines C-IV, 7.2), should the problems which led to the Article 17(2) declaration be overcome.