

No. 831,794.

PATENTED SEPT. 25, 1906.

K. LÖHLE.
MEANS FOR JOURNALING A VERTICAL SHAFT.
APPLICATION FILED MAY 7, 1906.

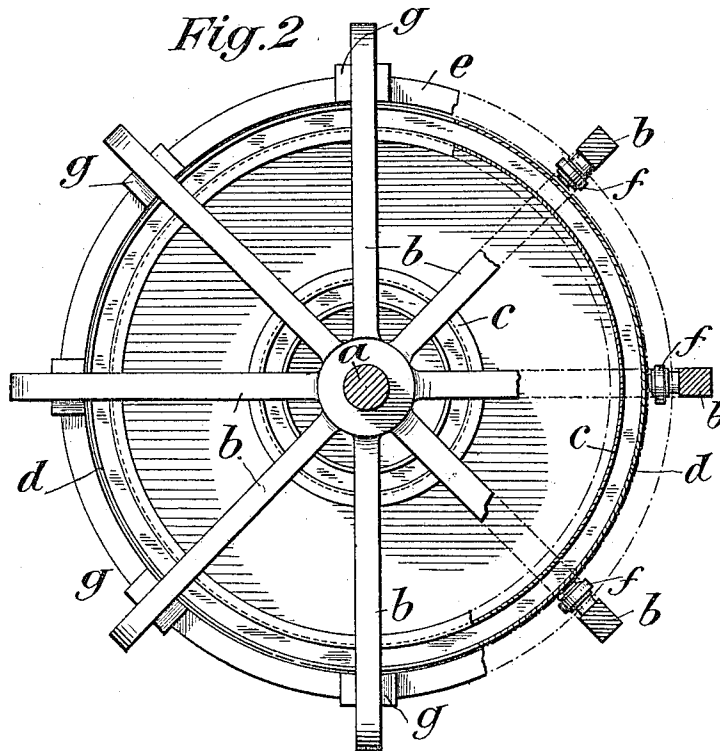
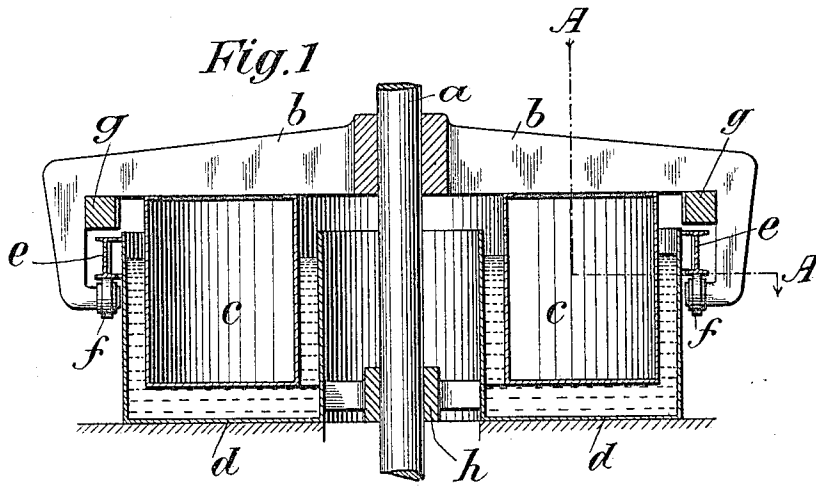

Witnesses:

W. Sommers
M. E. Beall

Inventor:

Karl Löhle
by *Henry Outh*
Att'y.

UNITED STATES PATENT OFFICE.

KARL LÖHLE, OF ZÜRICH, SWITZERLAND.

MEANS FOR JOURNALING A VERTICAL SHAFT.

No. 831,794.

Specification of Letters Patent.

Patented Sept. 25, 1906.

Application filed May 7, 1906. Serial No. 315,629.

To all whom it may concern:

Be it known that I, KARL LÖHLE, a citizen of the Republic of Switzerland, residing at Zürich, Switzerland, have invented new and useful Improved Means for Journaling Vertical Shafts, of which the following is a specification.

The object of the present invention is to provide means for journaling a vertical shaft. This contrivance comprises a float which operates in a receptacle containing a liquid and which is intended to carry the shaft, guiding means, and a brake device which serve to respectively retain the shaft in the vertical position and exert a braking action on the shaft upon the latter being loaded down beyond a predetermined limit.

In the accompanying drawings there is shown, by way of example, a device embodying my invention, in which—

Figure 1 is a vertical sectional elevation; and Fig. 2, a plan view, partly in horizontal section, on line A A of Fig. 1.

The vertical shaft or axle *a* is carried by means of the radiating bracket-arms *b* by the hollow float *c*, concentrically arranged about the shaft and having an annular form of rectangular cross-section. This float operates in a correspondingly annular trough *d*, likewise concentrically arranged about the shaft, which latter is centered in the bushing *h*. In order to prevent the shaft from assuming an oblique position, there is provided on the fixed trough *d* a circular running-board *e*, preferably of I-iron, upon the under face of which run the rollers *f*, secured to the bracket-arms *b*. The rollers are pressed against the runway *e* by the up pressure of the float. By regulating the liquid-level in the trough the degree of pressure exerted by the rollers *f* can be regulated so that moments of tilting acting on the shaft will have no influence on the vertical position thereof.

If for any reason the shaft *a* is overloaded, the float *c* will dip deeper into the liquid, with the result that the brake-shoes *g* cooperate with the runway *e*. These brake-shoes may

be secured directly to the radiating arms *b* or to an auxiliary framework carried by these arms.

It is obvious that the runway *e* could also be secured to the arms *b* instead of to the trough *d*, in which instance the rollers *f* and the brake-shoes *g* should be attached to the trough. I may also construct the walls of the trough *d* so that they serve as runway and brakeway.

Having now particularly described and ascertained the nature of the said invention and in what manner the same is to be performed, I declare that what I claim is—

1. Means for journaling a vertical shaft comprising a liquid-containing receptacle, a float therein adapted to carry a vertical shaft, and means external of the receptacle for guiding said float.

2. Means for journaling a vertical shaft, comprising a trough, a liquid therein, a float in said liquid adapted to carry a vertical shaft, means for horizontally guiding said float, and means for braking down said shaft.

3. Means for journaling a vertical shaft, comprising means for centering the shaft, a liquid-containing annular trough, a float therein carrying the shaft, radiating arms on said shaft, rollers and brake-shoes on said arms, and a runway and brakeway on said trough, alternately cooperating with said runway and brakeway.

4. Means for journaling a vertical shaft, comprising means for centering the shaft, a liquid-containing annular trough, arranged concentrically about said shaft, a float in said trough carrying said shaft, radiating arms on said shaft, and guiding and braking means connected with said trough and said arms respectively.

In testimony whereof I have signed my name to this specification in the presence of two subscribing witnesses.

KARL LÖHLE.

Witnesses:

A. LIEBERKNECHT,
MORITZ VEITH.