

(19)



(11)

EP 2 151 658 B1

(12)

EUROPEAN PATENT SPECIFICATION

(45) Date of publication and mention of the grant of the patent:
15.01.2014 Bulletin 2014/03

(51) Int Cl.:
F41A 19/01 (2006.01)

(21) Application number: **07765890.4**

(86) International application number:
PCT/ES2007/070105

(22) Date of filing: **30.05.2007**

(87) International publication number:
WO 2008/145773 (04.12.2008 Gazette 2008/49)

(54) DEVICE FOR CONTROLLING AMMUNITION CONSUMPTION IN REAL TIME

VORRICHTUNG ZUR ÜBERWACHUNG DES MUNITIONSVERBRAUCHS IN ECHTZEIT

DISPOSITIF PERMETTANT DE CONTRÔLER LA CONSOMMATION DE MUNITIONS EN TEMPS RÉEL

(84) Designated Contracting States:
AT BE BG CH CY CZ DE DK EE ES FI FR GB GR HU IE IS IT LI LT LU LV MC MT NL PL PT RO SE SI SK TR

(74) Representative: **Pons Ariño, Angel**
Pons Patentes y Marcas Internacional, S.L.
Glorieta Ruben Dario 4
28010 Madrid (ES)

(43) Date of publication of application:
10.02.2010 Bulletin 2010/06

(56) References cited:
EP-A1- 0 554 905 EP-A1- 1 574 805
WO-A1-2006/042876 WO-A1-2006/042876
ES-T3- 2 213 132 US-A- 4 541 191
US-A- 5 052 138 US-A- 5 142 805
US-A- 5 303 495 US-A- 5 406 730
US-A1- 2005 114 084 US-A1- 2005 114 084

(73) Proprietor: **Delgado Acarreta, Raul**
31500 Tudela (ES)

(72) Inventor: **Delgado Acarreta, Raul**
31500 Tudela (ES)

EP 2 151 658 B1

Note: Within nine months of the publication of the mention of the grant of the European patent in the European Patent Bulletin, any person may give notice to the European Patent Office of opposition to that patent, in accordance with the Implementing Regulations. Notice of opposition shall not be deemed to have been filed until the opposition fee has been paid. (Art. 99(1) European Patent Convention).

Description

OBJECT OF THE INVENTION

[0001] This invention refers, in general, to a device for counting shots fired with a firearm. More specifically, this invention refers to a device which counts the shots made with a firearm, albeit an automatic, semiautomatic or manual weapon, by means of the acquisition, analysis and interpretation of signals generated in the firearm's firing cycle. The device functions automatically, activating, disconnecting and setting at zero when the ammunition is consumed from the magazine in use, therefore the firearm user does not intervene in the operation of the aforementioned device, and furthermore is provided with information on the ammunition consumption in real time as it is produced.

STATE OF THE ART

[0002] Currently the improvement of firearms, such as short arms or pistols has led to a pistol magazine having a capacity to house more than a dozen cartridges, for example, 18 cartridges.

[0003] In a revolver type firearm, that is, a firearm which has drum normally able to hold 6 cartridges, it is relatively easy to mentally control the number of cartridges shot or used. In the case of a pistol which mounts a magazine which can store 18 20 cartridges, plus one in the chamber, the task of controlling the number of shots carried out may become arduous and complicated, and the shooter may be surprised with the last unexpected shot that is, without prior warning.

[0004] In automatic firearms, with a high shooting rate, between 250 and 1200 shots per minute, the problem is further aggravated as even the slightest excess of time pressing the trigger leads to an enormous waste of ammunition. In manual activation, even though the amount of ammunition spent is much more restrained, as we will be able to keep count of the ammunition spent and the total number of shots fired with the firearm.

Document WO2006/042876 A1 discloses an ammunition consumption control device in real time for a firearm according to the preamble of claim 1. Other prior art useful to understand the invention is EP 1 574 805 A1, US 5 406 730, US 2005/0114084 A1 and US 5 142 805.

CHARACTERISATION OF THE INVENTION

[0005] This invention seeks to resolve or reduce one or more of the disadvantages described above by means of an automatic shot counter such as that defined in claim 1. Embodiments of the invention are established in the dependent claims.

[0006] One object of the invention is to provide a device which is able to count and show, in real time, the number of shots fired with the firearm by means of the weapon's firing cycle.

[0007] The shot counter in this invention counts the number of shots fired with the firearm which has a dynamic or static firing cycle.

[0008] A dynamic firing cycle is that which is fired by an automatic or semiautomatic firearm, which includes at least the mechanical actions of shooting, hammering and loading in such a way that it is prepared for the next shot and which implies movement of specific mechanical elements. Each dynamic cycle corresponds to a partial count and the sum of all the partial counts, that is, the shots fired, corresponds to a total count of the number of shots fired by the firearm throughout its operative life.

[0009] In turn, the static firing cycle is defined as that made by a firearm which comprises, at least, the mechanical action of shooting, and in which the operations of introducing the cartridge into the chamber and extraction of the spent cartridge are made manually. Each static cycle corresponds to a partial count and the sum of all the partial counts, that is, the shots fired, corresponds to a total count of the number of shots fired by the firearm throughout its operative life

[0010] The result of these counts is shown, in real time, in a visual display unit which may or may not be incorporated in the firearm, thus forming part of the shooter's equipment, or of a data collection centre of a multiplicity of shooters. As a result, the shooter is able to know the number of cartridges available at any given movement, permitting him to more effectively control consumption of the ammunition and avoiding the dangerous surprise of running out of ammunition at a highly emotional tense moment.

[0011] Furthermore, the total counter of the shots fired by the firearm enable perfect maintenance of those parts which undergo most wear during use, thus preventing irreparable damage to the firearm.

[0012] In firearms which make dynamic firing cycles, the count thereof is made in one of the following two ways In the first, on the basis of times and speeds of displacement of a linear or rotational movement of an element which is displaced in reaction to the shot, thus forming part of the firearm's closing system.

[0013] In the second, on the basis of the characteristics of the disturbances generated in at least one element of the firearm when the shot occurs. Parameters which characterise a disturbance may be for example, amplitude, duration etc. of the disturbance.

[0014] It should be noted that in both cases it is possible to differentiate the action of shooting of any manual action made by the user thereof. It also enables identification of the last available cartridge which permits the automatic setting at zero of the partial counter.

[0015] In a firearm which makes static firing cycles, the count thereof is made on the basis of the characteristics of the disturbances generated in at least one element of the firearm when the shot is produced. Parameters which characterise a disturbance may be for example, amplitude, duration etc. of the disturbance.

[0016] In this case it is also possible to differentiate the

action of shooting from any other manual action carried out by the shooter.

[0017] The dynamic cycle may be complete or incomplete. A dynamic cycle should be considered to be complete when it ends with a new cartridge fed into the chamber and, therefore, ready to be fired. The dynamic cycle is incomplete when the firearm is unloaded as there are no more cartridges in the magazine or as it has jammed, that is, the firearm cannot fire again until a new magazine has been inserted.

[0018] Another object of the invention is its ability to ensure visibility in real time of the partial and total count in a visual display unit, situated in the firearm itself or in a device situated at a distance from the firearm which is firing the shot and in any situation when using the firearm.

[0019] Another object of the invention is to make a light-weight counter with reduced dimensions which does not interfere with the use of the firearm and which is simple to mount both in long and short arms, of the type already in existence or new manufacture.

[0020] A further object of the invention is that the counter has considerable operational autonomy, including several thousand shots, as a result of its reduced electrical energy consumption. This autonomy is achieved by means of electronic circuits which remain in repose until a shot is fired. At that moment the counter is automatically activated, presents the information relating to the partial count, that is, that which corresponds to the magazine which is being used, during a pre-established time period and finally it returns to the resting position until the next shot.

[0021] Another object of the shot counter is that the shooter does not intervene or interfere in its operation. When a shot is fired, the counter is activated, it memorises the information, shows it during a pre-established time period on the visual display unit so that it does not distract the shooter's attention any longer than necessary and prevents its position from being visible in the dark and returns to its resting state until the next shot. If the user wishes to consult the number of shots fired, a button is activated for this purpose, causing the stored information to be shown on the visual display unit for a number of seconds.

[0022] Another object of the invention is to provide useful information in order to assess the ageing and wear of the main components of the firearm by means of analysis of the firing cycles made with the arm throughout its lifetime.

[0023] Another object of the invention is to use the visual display unit and the electronic circuits of the shot counter to show other information inherent to the operation of the firearm such as, for example, the barrel temperature. In this way we will be able to avoid excessive temperature values during intensive use, in short periods of time, as these could affect the firearm's precision or endanger the shooter and/or the firearm.

BRIEF DESCRIPTION OF THE FIGURES

[0024] A more detailed explanation of the invention is given in the following description based on the attached figures in which:

[0025] Figures 1a and 1b show projected views of a firearm with a counter device in accordance with this invention.

[0026] Figures 2a, 2b, and 2c show profile views of the shot counter in accordance with the invention and

[0027] Figure 3 shows a block diagram of the shot counter device in accordance with the invention.

DESCRIPTION OF THE INVENTION

[0028] Below, figures 1a, 1b, 2a, 2b and 2c show illustrations of shot counter devices 12 for firearms 11, for example, pistols and rifles which include a viewing panel 21 placed preferably round the firearm's aiming system, so that the screen in itself is oriented towards the shooter's sight, and therefore, within the field of vision of the sighting system.

[0029] Figure 3 shows a block diagram of the shot counter 12 which includes a first means of perception or sensor 32 which is adapted to perceive certain physical characteristics relating to the action of the shot made with the firearm 11.

[0030] In the case of a firearm with a dynamic firing cycle, the function of counting the number of shots fired is based on the times or speeds of displacement of an element associated with the firearm's closing system for example. In this case, the sensor 32 includes one or more sensors which may be magnetic, or of the electromagnetic radiation type, irrespective of whether or not they are visible to the human eye, or a combination of these. In order for the sensor 32 to be able to perceive the shot, the aforementioned sensor perceives a solid medium 31 which participates from movement of the alternative sliding, backwards and forwards once more, from at least one element of the closing system of the firearm 11.

[0031] When the sensor 32 is of the magnetic type, the aforementioned solid means 31 is, at least, a magnet situated on the slide or closing system of the firearm, with the possibility of the actual slide being the aforementioned means 31, in which case an auxiliary magnet will be placed close to the sensor 32. When the sensor 32 is of the type with electromagnetic radiations, the solid medium 31 is, at least, a reflective layer or surface situated on the slide or firearm closing system, with the aforementioned means 31 being the slide itself.

[0032] In addition, the firearm which carries out a firing cycle may obtain information in order to count the shots carried out on the basis of the characteristics of the dynamic disturbances suffered by the firearm when it fires a shot. Therefore, the sensor 32, includes one or more vibration sensors such as for example of the piezoelectric type.

[0033] In the case of a firearm which carries out static

firing cycles, the function of counting the number of shots fired is based on the characteristics of the dynamic disturbances to which the firearm 11 is subject in a similar manner to the previously mentioned case. As a result, the sensor 32, includes one or more vibration sensors such as for example of the piezoelectric type as well.

[0034] When a shot is fired brusque and strong dynamic disturbances of the firearm occur. Furthermore, in the firearm 11 with dynamic firing cycle, there is a strong acceleration of the slide or closing system, in the opposite direction of the shot, in general, due to conservation of the movement amount.

[0035] When the slide reaches the end of its run or the closing system causes a backward thrust and driven by the recovery spring it changes the direction of its movement returning forwards again until the firing cycle is completed. Both phenomena are very different from those produced by an accidental blow or by handling of the firearm 11 by the shooter.

[0036] The first means of perception or sensor 32 will directly receive, or through the solid medium 31, the characteristics of the firearm shot 11. The sensor 32 generates at one of its exits an electrical signal which is sent, through electrical connections to a programmable logical control means 33 which, in turn is connected to the visual display unit 21.

[0037] The electrical signal generated is analysed and compared with the signal model corresponding to a shot. In the event that they are equal or substantially similar, the microprocessor 33 varies in a unit both in terms of the number of total shots fired with a firearm 11, total count, such as the number of shots fired with the magazine 13 mounted to the firearm 11, partial count.

[0038] Previously the model electrical signal corresponding to the type of firing cycle characteristic of the firearm 11, dynamic or static, would have been stored in the microprocessor memory 33. This information is a characteristic parameter of each firearm 11 and of the type of ammunition used thereby, so that it is possible to distinguish between a complete and an incomplete cycle as well as handling of the slide by the shooter and the jamming of the weapon or when the casing is trapped by the closing system.

[0039] The programmable logic control means 33 based on a programming means such as a microprocessor, may be connected to an data entry means 34 which includes one or various switches or buttons which permit the selection and visual display in real time on the counter screen 21 the information required by the shooter at any time, such as the total count or partial count etc.

[0040] The partial counter automatically sets to zero when the microprocessor 33 identifies an incomplete dynamic firing cycle, or in another exemplary embodiment, when it identifies that the shooter has acted manually on the slide or closing system of the firearm 11.

[0041] It may also be set at zero with a button included for this purpose or when the loader is changed for another by means of a mechanical microswitch or a magnetic

type sensor, not shown in the drawings, placed on the firearm 11 and a magnet inserted in the loader 13.

[0042] The counter 12 may be configured as an accessory which is coupled to the body of the firearm 11, to any of the firearm components 11 or to any of its accessories; as a system which is housed or embedded in the firearm casing in any of the firearm 11 components, or in any of its accessories etc; so that the screen 21 may be visualised at any time by the shooter when firing a shot, that is, the screen 21 is facing towards the shooter.

[0043] The microprocessor information 33 may be transmitted through electrical connections, or through any means of transmission of information via an air interface to a receiver and data processing system and/or another visual display unit not shown in the drawings which form part of the shooter's equipment, or distanced therefrom.

[0044] The counter 12 comprises a supply unit in the form of a battery or cell 35, not shown, which supplies electrical energy to all counter circuits 12. The battery 35 is small in size and of the long term type. Rechargeable batteries may also be used.

[0045] In order to extend the battery life 35, the counter 12 is automatically activated when a shot is fired. Initially it is in repose, with the visual display unit turned off. When the firearm fires, the sensor 32 generates a signal activating the counter 12. Following a predetermined period of non use of the fire arm, the counter returns to its resting position, maintaining the value of the counters both total and partial.

[0046] The counter 12 may also be automatically activated by an impact sensor, a magnetic switch or a piezoelectric sensor which picks up the mechanical vibrations of the firearm 11 when it fires.

[0047] The counter 12 may also include buttons for carrying out further functions such as: exclusively switching off the screen without affecting the counter as it continues incrementing as new shots are fired or selecting a certain number on the visual display unit 21 so that the counter 12 discounts a unit every time that a new shot is fired.

[0048] The visual display unit may be of the liquid crystal type LCD, electroluminescent, plasma, coherent light or similar, due to the fact that these technologies consume very little power.

[0049] The screen information 21 will be shown with different degrees of light intensity in accordance with ambient light available at any given time in order to facilitate viewing at all times. In this way it will be notably reduced when the intensity of ambient light is low or dark and it will increase when the opposite is the case.

[0050] In respect of figures 1a, 1b, 2a, 2b and 2c, the screen 21 will comprise at least two digits which may be together or separate. It may also be formed by 1½ digits, namely, by a complete digit and another formed solely by two vertical segments aligned in such a way that as they take up a small amount of space it will be easier to integrate them in small firearms. In this case, for the count of more than 20 shots for example, the points at the foot

of each digit will be used in order to codify the information.

[0051] In order to have evidence of the temperature in the barrel of the firearm at least one temperature probe may be placed, not shown in the figures, at an appropriate point of the barrel. This probe generates an electrical signal based on its temperature which is sent, through electrical connections, to the programmable logic control means 33.

[0052] Although the value of the temperature may appear on the visual display unit when activated by the button, in the preferred embodiment it is shown indirectly through the mode which visualises the partial counter. For example, with its intermittent flashing with two different frequencies corresponding to the two temperature scales, one lower for warning and one higher for danger, which have been previously established in the programmable logic control means 33.

[0053] In order to avoid placing long electrical connections along the firearm 11, the temperature probe may be placed at another part of the firearm so that measuring the temperature at that point infers the same, given that the temperature at both points is related given since weapon in question is the same article.

[0054] The embodiments and examples established in this report are presented as the best explanation of this invention and its practical application, and thus permitting experts in the art to put this invention into practice and use.

Claims

1. Device for controlling ammunition consumption, in real time for a firearm (11) which makes the mechanical action of firing, the firearm (11) comprising a chamber for mounting a magazine (13), wherein the counting device (12) comprises a sensor (32) which is adapted to perceive the movement of a means (31) solid to a mobile mechanical element of the firearm which moves as a result of a shot and/or which is adapted to perceive mechanical disturbances generated during the shot of a cartridge; the aforementioned sensor (32) is adapted to generate an electric signal which is sent to a programmable logic control means (33) so that a count in a counter unit stored in said programmable logic control means (33) varies according to the number of shots fired by the firearm (11) or to the number of shots fired with the magazine (13) mounted to the firearm (11) or to the number of cartridges available in the magazine (13), in turn, the programmable logic control means (33) is adapted to send said count generated to a visual display unit (21), wherein the count is based on the realisation of a dynamic firing cycle which includes at least the mechanical actions of shooting, hammering and loading in such a way that an automatic or semiautomatic firearm (11) is prepared for the next shot implying movement of specific mechanical elements,

or based on the realisation of a static firing cycle which includes at least the mechanical action of shooting, and in which the operations of introducing the cartridge into the chamber and extraction of the spent cartridge are made manually **characterised in that** the programmable logic control means is configured such that the count corresponding to the number of shots fired with the magazine (13) mounted to the firearm (11) automatically sets to zero when the counting device (12) identifies the shot of the last available cartridge by an incomplete dynamic firing cycle.

2. **Device** in accordance with claim 1; **characterised in that** the counting device (12) varies the count in the counter unit according to the number of shots fired with the firearm (11) based on the realisation of the dynamic firing cycle compared to the time and/or speed standards of the mobile mechanical element characteristic of the firearm (11) previously stored in the programmable logic control means (33).

3. **Device** in accordance with claim 1; **characterised in that** in the counting device (12) varies the count in the counter unit according to the number of shots fired with the firearm (11) based on the realisation of the dynamic firing cycle compared to the standard value of characteristic mechanical disturbance of the firearm (11), with said value having been previously stored in the programmable logic control means (33).

4. **Device** in accordance with claim 1; **characterised in that** the counting device (12) is automatically activated through the perception or sensor medium (32) by an impact or piezoelectric sensor, or magnetic switch when the firearm is used; following a predetermined period the counter (12) returns to its resting position maintaining the value of the counters, both total and partial.

5. **Device** in accordance with claim 1; **characterised in that** the counting device (12) is equipped with a mechanical sensor and the magazine (13) with a magnet, in order to effect the automatic setting to zero of the partial counter when the magazine is replaced.

6. **Device** in accordance with claim 1; **characterised in that** the counting device (12) is equipped with a microswitch for automatically setting the partial counter to zero when the magazine is substituted.

7. **Device** in accordance with claim 1, **characterised in that** the sensor (32) comprises one or more sensors which may be of the magnetic type, or electromagnetic, visible or not to the human eye, by a combination thereof situated on the firearm (11) or by one or more vibration sensors for example, of the

piezoelectric type.

8. **Device** in accordance with claim 7, **characterised in that** the solid means (31) is the actual slide or at least a layer or a reflective surface situated on the slide or closing system of the firearm when the sensor (32) is of the electromagnetic radiation type. 5
9. **Device** in accordance with claim 7, **characterised in that** the solid means (31) is the actual slide or at least a magnet situated on the slide or closing system of the firearm (11) when the sensor (32) is of the magnetic type. 10
10. **Device** in accordance with claim 9; **characterised in that** an auxiliary magnet is placed next to the sensor (32) when the solid means (31) is the actual slide. 15
11. **Device** in accordance with claim 1; **characterised in that** the counting device (12) varies the count in the counter unit according to the number of shots fired with the firearm (11) based on the realisation of the static firing cycle compared to the standard value of characteristic mechanical disturbance of the firearm (11), with said value having been previously stored in the programmable logic control means(33). 20
12. **Device** in accordance with claim 11; **characterised in that** the sensor 32 includes one or more vibration sensors, for example, of the piezoelectric type. 25
13. **Device** in accordance with claim 1; **characterised in that** it includes a data entry means (34) which is adapted to select at least one item of information stored in the programmable logic medium (33) so that the type of information selected is shown in real time, visually on the visual display unit (21) 30
14. **Device** in accordance with claim 13; **characterised in that** the data entry means (34) consist of one or various buttons. 35
15. **Device** in accordance with claim 14; **characterised in that** the counting device (12) is affixed to the firearm (11) in such a way that the visual display unit (21) is facing towards the shooter. 40
16. **Device** in accordance with claim 14; **characterised in that** an element of the firearm (11) is adapted to receive the counting device (12) in such a way that the visual display unit (21) is facing towards the shooter. 45
17. **Device** in accordance with claim 14; **characterised in that** the counting device (12) is adapted to be integrated in an accessory which is coupled to the firearm (11) in such a way that the visual display unit (21) is facing towards the shooter. 50
18. **Device** in accordance with any of claims 15 to 17; **characterised in that** the visual display unit(21) is a liquid crystal, electroluminescent, plasma, coherent light screen or similar and is situated in the environment of the sighting system of the firearm (11). 55
19. **Device** in accordance with claim 18; **characterised in that** the information stored in the programmable logic medium (33) may be transmitted through electrical connections, or through a transmission means which uses an air interface in order to transmit information, to a reception and data processing system and /or may be shown on another visual display unit different from the screen (21).
20. **Device** in accordance with claim 19; **characterised in that** the counting device (12) is equipped with different buttons for setting the partial counter to zero, switching the visual display unit on or off or pre-establishing a certain number on the visual display unit (21) in such a way that the counter (12) discounts a unit each time that the new shot is fired.
21. **Device** in accordance with claim 18; **characterised in that** the information displayed on the visual display unit may be shown with different light intensities in order to adapt to the intensity of the ambient lighting.
22. **Device** in accordance with claim 18; **characterised in that** the visual display unit may additionally show information relating to the temperature of the barrel of the firearm.
23. **Device** in accordance with claim 22; **characterised in that** the temperature of the barrel of the firearm may be shown with a temperature value.
24. **Device** in accordance with claim 22; **characterised in that** the temperature of the barrel of the firearm may be shown indirectly by means of the manner in which the value of the partial counter is shown.
25. **Firearm** which incorporates a device in accordance with any of the previous claims.

Patentansprüche

1. Vorrichtung zur Steuerung des Munitionsverbrauchs einer Schusswaffe (11) in Echtzeit, welche die mechanische Funktion der Schussabgabe durchführt, wobei die Schusswaffe (11) eine Kammer zur Befestigung eines Magazins (13) umfasst, bei der die Zählvorrichtung (12) einen Sensor (32) umfasst, der zur Erkennung der Bewegung eines Mittels (31) ausgelegt ist, das fest mit einem mobilen mechanischen Element der Schusswaffe verbunden ist, das sich

- als Resultat eines Schusses bewegt, und/oder der dazu ausgelegt ist, mechanische Störungen zu erkennen, die während des Schusses einer Patronenhülse erzeugt werden; wobei der vorstehend erwähnte Sensor (32) dazu ausgelegt ist, ein elektrisches Signal zu erzeugen, das an ein speicherprogrammierbares Steuerungsmittel (33) gesendet wird, sodass eine in dem besagten speicherprogrammierbaren Steuerungsmittel (33) gespeicherte Zählung in einer Zählereinheit entsprechend der Anzahl der von der Schusswaffe (11) abgegebenen Schüsse oder der Anzahl der mit dem an der Schusswaffe (11) befestigten Magazin abgegebenen Schüsse oder der Anzahl der in dem Magazin (13) verfügbaren Patronenhülsen variiert, wobei das speicherprogrammierbare Steuerungsmittel (33) seinerseits dazu ausgelegt ist, die erzeugte Zählung an eine visuelle Anzeigeeinheit (21) zu senden, wobei die Zählung auf der Durchführung eines dynamischen Schussabgabezyklus beruht, der mindestens die mechanischen Funktionen des Schießens, der Hahnbetätigung und der Ladung auf solche Weise einschließt, dass eine automatische oder halb automatische Schusswaffe (11) für den nächsten Schuss vorbereitet wird, was die Bewegung spezifischer mechanischer Elemente beinhaltet, oder auf der Durchführung eines statischen Schussabgabezyklus beruht, der mindestens die mechanische Funktion des Schießens einschließt und bei dem die Arbeitsschritte des Einführens der Patronenhülse in die Kammer und der Ausgabe der verbrauchten Patronenhülse manuell durchgeführt werden, **dadurch gekennzeichnet, dass** das speicherprogrammierbare Steuerungsmittel so ausgelegt ist, dass die Zählung entsprechend der Anzahl der mit dem an der Schusswaffe (11) befestigten Magazin (13) abgefeuerten Schüsse automatisch auf null gesetzt wird, wenn die Zählvorrichtung (12) den Schuss der letzten verfügbaren Patronenhülse mittels eines unvollständigen dynamischen Schussabgabezyklus identifiziert.
2. Eine Vorrichtung nach Anspruch 1, **dadurch gekennzeichnet, dass** die Zählvorrichtung (12) die Zählung in der Zählereinheit entsprechend der Anzahl der mit der Schusswaffe (11) abgegebenen Schüsse beruhend auf der Durchführung des dynamischen Schussabgabezyklus im Vergleich zu den Zeit- und/oder Geschwindigkeitsstandards des mobilen mechanischen Elements variiert, welche die Schusswaffe (11) kennzeichnen und vorher in dem speicherprogrammierbaren Steuerungsmittel (33) gespeichert wurden.
3. Eine Vorrichtung nach Anspruch 1, **dadurch gekennzeichnet, dass** die Zählvorrichtung (12) die Zählung in der Zählereinheit entsprechend der Anzahl der mit der Schusswaffe (11) abgegebenen Schüsse
- beruhend auf der Durchführung des dynamischen Schussabgabezyklus im Vergleich zum Standardwert der charakteristischen mechanischen Störung der Schusswaffe (11) variiert, wobei der besagte Wert vorher in den speicherprogrammierbaren Steuerungsmitteln (33) gespeichert wurde.
4. Eine Vorrichtung nach Anspruch 1, **dadurch gekennzeichnet, dass** die Zählvorrichtung (12) automatisch über das Erkennungs- oder Sensormittel (32) von einem Aufprall- oder piezoelektrischen Sensor oder einem Magnetschalter betätigt wird, wenn die Schusswaffe benutzt wird; wobei der Zähler (12) nach einer vorgegebenen Zeit zu seiner Ruheposition zurückkehrt und die Werte der Zähler, sowohl des Gesamt- als auch des Teilzählers, bewahrt.
5. Eine Vorrichtung nach Anspruch 1, **dadurch gekennzeichnet, dass** die Zählvorrichtung (12) mit einem mechanischen Sensor und das Magazin (13) mit einem Magnet ausgestattet sind, um die automatische Einstellung des Teilzählers auf null durchzuführen, wenn das Magazin ausgetauscht wird.
6. Eine Vorrichtung nach Anspruch 1, **dadurch gekennzeichnet, dass** die Zählvorrichtung (12) mit einem Mikroschalter zur automatischen Einstellung des Teilzählers auf null ausgestattet ist, wenn das Magazin ausgetauscht wird.
7. Eine Vorrichtung nach Anspruch 1, **dadurch gekennzeichnet, dass** der Sensor (32) einen oder mehrere Sensoren umfasst, die magnetischer oder elektromagnetischer Art, dem menschlichen Auge sichtbar oder nicht sichtbar, eine Kombination derselben auf der Schusswaffe (11) oder einer oder mehreren Vibrationssensoren sein können, beispielsweise von der Art eines piezoelektrischen Sensors.
8. Eine Vorrichtung nach Anspruch 7, **dadurch gekennzeichnet, dass** das feste Mittel (31) der Schlitten selbst oder mindestens eine Schicht oder eine reflektierende Oberfläche auf dem Schlitten oder dem Schließsystem der Schusswaffe ist, wenn der Sensor (32) der Art eines elektromagnetischen Strahlungssensors entspricht.
9. Eine Vorrichtung nach Anspruch 7, **dadurch gekennzeichnet, dass** das feste Mittel (31) der Schlitten selbst oder mindestens ein Magnet auf dem Schlitten oder dem Schließsystem der Schusswaffe (11) ist, wenn der Sensor (32) der Art eines Magnetsensors entspricht.
10. Eine Vorrichtung nach Anspruch 9, **dadurch gekennzeichnet, dass** ein Hilfsmagnet neben dem Sensor (32) platziert wird, wenn das feste Mittel (31) der Schlitten selbst ist.

11. Eine Vorrichtung nach Anspruch 1, **dadurch gekennzeichnet, dass** die Zählvorrichtung (12) die Zählung in der Zählereinheit entsprechend der Anzahl der mit der Schusswaffe (11) abgegebenen Schüsse beruhend auf der Durchführung des statischen Schussabgabezyklus im Vergleich zu dem Standardwert der charakteristischen mechanischen Störung der Schusswaffe (11) variiert, wobei dieser Wert vorher in dem speicherprogrammierbaren Steuerungsmittel (33) gespeichert wurde. 5
12. Eine Vorrichtung nach Anspruch 11, **dadurch gekennzeichnet, dass** der Sensor (32) einen oder mehrere Vibrationssensoren einschließt, beispielsweise der piezoelektrischen Art. 10
13. Eine Vorrichtung nach Anspruch 1, **dadurch gekennzeichnet, dass** diese ein Dateneingabemittel (34) einschließt, das dazu ausgelegt ist, mindestens eine in dem speicherprogrammierbaren Steuerungsmittel (33) gespeicherte Informationsposition auszuwählen, damit die Art der ausgewählten Information in Echtzeit sichtbar auf der visuellen Anzeigeeinheit (21) angezeigt wird. 15
14. Eine Vorrichtung nach Anspruch 13, **dadurch gekennzeichnet, dass** die Dateneingabemittel (34) aus einer oder mehreren Tasten bestehen. 20
15. Eine Vorrichtung nach Anspruch 14, **dadurch gekennzeichnet, dass** die Zählvorrichtung (12) an der Schusswaffe (11) auf eine solche Weise befestigt ist, dass die visuelle Anzeigeeinheit (21) in Richtung des Schützen zeigt. 25
16. Eine Vorrichtung nach Anspruch 14, **dadurch gekennzeichnet, dass** ein Element der Schusswaffe (11) dazu ausgelegt ist, die Zählvorrichtung (12) auf eine solche Weise aufzunehmen, dass die visuelle Anzeigeeinheit (21) in Richtung des Schützen zeigt. 30
17. Eine Vorrichtung nach Anspruch 14, **dadurch gekennzeichnet, dass** die Zählvorrichtung (12) dazu ausgelegt ist, in ein Zubehörteil integriert zu werden, das auf eine solche Weise mit der Schusswaffe (11) gekoppelt ist, dass die visuelle Anzeigeeinheit (21) in Richtung des Schützen zeigt. 35
18. Eine Vorrichtung nach Anspruch 15 bis 17, **dadurch gekennzeichnet, dass** die visuelle Anzeigeeinheit (21) ein Flüssigkristall-, Elektrolumineszenz-, Plasma-, kohärenter Lichtbildschirm oder Ähnliches ist und in der Umgebung des Visiersystems der Schusswaffe (11) angeordnet ist. 40
19. Eine Vorrichtung nach Anspruch 18, **dadurch gekennzeichnet, dass** die in dem speicherprogrammierbaren Steuerungsmittel (33) gespeicherte Information über elektrische Verbindungen oder über ein Übertragungsmittel übertragen werden kann, das eine Luftschnittstelle verwendet, um Informationen an ein System zum Empfang und zur Verarbeitung von Daten zu übertragen, und / oder auf einer anderen visuellen Anzeigeeinheit als dem Bildschirm (21) angezeigt werden kann. 45
20. Eine Vorrichtung nach Anspruch 19, **dadurch gekennzeichnet, dass** die Zählvorrichtung (12) mit unterschiedlichen Tasten zur Einstellung des Teilzählers auf null ausgestattet ist, wobei die visuelle Anzeigeeinheit ein- oder ausgeschaltet oder eine bestimmte Zahl auf der visuellen Anzeigeeinheit (21) in einer solchen Weise vorab festgelegt wird, dass der Zähler (12) jedes Mal eine Einheit abzieht, wenn ein neuer Schuss abgegeben wird. 50
21. Eine Vorrichtung nach Anspruch 18, **dadurch gekennzeichnet, dass** die auf der visuellen Anzeigeeinheit angezeigte Information mit unterschiedlichen Lichtstärken angezeigt werden kann, um diese an die Stärke der Umgebungsbeleuchtung anzupassen. 55
22. Eine Vorrichtung nach Anspruch 18, **dadurch gekennzeichnet, dass** die visuelle Anzeigeeinheit zusätzlich Informationen bezüglich der Temperatur der Trommel der Schusswaffe anzeigen kann.
23. Eine Vorrichtung nach Anspruch 22, **dadurch gekennzeichnet, dass** die Temperatur der Trommel der Schusswaffe mit einem Temperaturwert angezeigt werden kann.
24. Eine Vorrichtung nach Anspruch 22, **dadurch gekennzeichnet, dass** die Temperatur der Trommel der Schusswaffe indirekt über die Art und Weise angezeigt werden kann, wie der Wert des Teilzählers angezeigt wird.
25. Schusswaffe, die eine Vorrichtung nach einem der vorhergehenden Ansprüche einschließt.

Revendications

1. **Dispositif de commande de la consommation de munitions** en temps réel pour une arme à feu (11) qui accomplit l'action mécanique de tir, l'arme à feu (11) comprenant une chambre pour le montage d'un chargeur (13), dans lequel le compteur (12) comprend un capteur (32) qui est adapté pour percevoir le mouvement d'un moyen (31) fixé à un élément mécanique mobile de l'arme à feu qui se déplace sous l'effet d'un tir et/ou qui est adapté pour percevoir des perturbations mécaniques générées durant le tir d'une cartouche ; le capteur susmentionné (32)

est adapté pour générer un signal électrique qui est envoyé à un moyen de commande logique programmable (33) de façon à ce qu'un décompte dans une unité de comptage enregistré dans ledit moyen de commande logique programmable (33) varie en fonction du nombre de coups tirés par l'arme à feu (11) ou du nombre de coups tirés avec le chargeur (13) monté sur l'arme à feu (11) ou du nombre de cartouches disponibles dans le chargeur (13), quant au moyen de commande logique programmable (33) il est lui adapté pour envoyer ledit décompte généré à un terminal à écran de visualisation (21), dans lequel le décompte est basé sur la réalisation d'un cycle de tirs dynamiques qui comprend au moins les actions mécaniques consistant à tirer, marteler et charger de façon à ce qu'une arme à feu automatique ou semi-automatique (11) soit préparée pour le tir suivant en impliquant le déplacement d'éléments mécaniques spécifiques, ou basé sur la réalisation d'un cycle de tirs statiques qui comprend au moins l'action mécanique consistant à tirer, et dans lequel les opérations d'introduction de la cartouche dans la chambre et d'extraction de la cartouche usagée sont faites manuellement **caractérisé en ce que** le moyen de commande logique programmable est configuré de façon à ce que le décompte correspondant au nombre coups tirés avec le chargeur (13) monté sur l'arme à feu (11) soit automatiquement remis à zéro lorsque le compteur (12) identifie le tir de la dernière cartouche disponible par un cycle de tirs dynamiques incomplet.

2. **Dispositif** selon la revendication 1, **caractérisé en ce que** le compteur (12) modifie le décompte dans l'unité de comptage en fonction du nombre de coups tirés avec l'arme à feu (11) à partir de la réalisation du cycle de tirs dynamiques par comparaison avec les critères de temps et/ou vitesse de l'élément mécanique mobile caractéristique de l'arme à feu (11) préalablement enregistrés dans le moyen de commande logique programmable (33).
3. **Dispositif** selon la revendication 1, **caractérisé en ce que** le compteur (12) modifie le décompte dans l'unité de comptage en fonction du nombre de coups tirés avec l'arme à feu (11) à partir de la réalisation du cycle de tirs dynamiques par comparaison avec la valeur standard de perturbation mécanique caractéristique de l'arme à feu (11), ladite valeur ayant été préalablement enregistrée dans le moyen de commande logique programmable (33).
4. **Dispositif** selon la revendication 1, **caractérisé en ce que** le compteur (12) est activé automatiquement via le support de perception ou capteur (32) par un capteur de choc ou piézoélectrique, ou un interrupteur magnétique lorsque l'arme à feu est utilisée, après une période prédéterminée le compteur (12)

revient à sa position de repos en conservant la valeur des compteurs, totaux et partiels.

5. **Dispositif** selon la revendication 1, **caractérisé en ce que** le compteur (12) est équipé d'un capteur mécanique et le chargeur (13) d'un aimant, afin d'effectuer la remise à zéro automatique du compteur partiel lorsque le chargeur est remis en place.
6. **Dispositif** selon la revendication 1, **caractérisé en ce que** le compteur (12) est équipé d'un micro-interrupteur pour remettre automatiquement le compteur partiel à zéro lorsque le chargeur est remplacé.
7. **Dispositif** selon la revendication 1, **caractérisé en ce que** le capteur (32) comprend un ou plusieurs capteurs qui peuvent être de type magnétique, ou électromagnétique, visibles ou non pour l'oeil humain, par une de leurs combinaisons située sur l'arme à feu (11) ou par un ou plusieurs capteurs de vibrations par exemple, de type piézoélectrique.
8. **Dispositif** selon la revendication 7, **caractérisé en ce que** le moyen fixé (31) est la coulisse effective ou au moins une couche ou une surface réfléchissante située sur la coulisse ou système de fermeture de l'arme à feu lorsque le capteur (32) est de type à rayonnement électromagnétique.
9. **Dispositif** selon la revendication 7, **caractérisé en ce que** le moyen fixé (31) est la coulisse effective ou au moins un aimant situé sur la coulisse ou système de fermeture de l'arme à feu (11) lorsque le capteur (32) est de type magnétique.
10. **Dispositif** selon la revendication 9, **caractérisé en ce qu'un** aimant auxiliaire est placé près du capteur (32) lorsque le moyen fixé (31) est la glissière effective.
11. **Dispositif** selon la revendication 1, **caractérisé en ce que** le compteur (12) modifie le décompte dans l'unité de comptage en fonction du nombre de coups tirés avec l'arme à feu (11) à partir de la réalisation du cycle de tirs statiques par comparaison avec la valeur standard de perturbation mécanique caractéristique de l'arme à feu (11), ladite valeur ayant été préalablement enregistrée dans le moyen de commande logique programmable (33).
12. **Dispositif** selon la revendication 11, **caractérisé en ce que** le capteur (32) comprend un ou plusieurs capteurs de vibrations, par exemple, de type piézoélectrique.
13. **Dispositif** selon la revendication 1, **caractérisé en ce qu'il** comprend un moyen d'introduction de données (34) qui est adapté pour sélectionner au moins

une information enregistrée dans le support logique programmable (33) pour que le type d'information sélectionné apparaisse en temps réel, sur l'unité de visualisation (21).

14. **Dispositif** selon la revendication 13, **caractérisé en ce que** le moyen d'introduction de données (34) est constitué d'un ou plusieurs boutons.
15. **Dispositif** selon la revendication 14, **caractérisé en ce que** le compteur (12) est assemblé à l'arme à feu (11) de façon à ce que l'unité de visualisation (21) soit en face du tireur.
16. **Dispositif** selon la revendication 14, **caractérisé en ce qu'**un élément de l'arme à feu (11) est adapté pour recevoir le compteur (12) de façon à ce que l'unité de visualisation (21) soit en face du tireur.
17. **Dispositif** selon la revendication 14, **caractérisé en ce que** le compteur (12) est adapté pour être intégré dans un accessoire qui est couplé à l'arme à feu (11) de façon à ce que l'unité de visualisation (21) soit en face du tireur.
18. **Dispositif** selon n'importe laquelle des revendications 15 à 17, **caractérisé en ce que** l'unité de visualisation (21) est un écran à cristaux liquides, électroluminescent, plasma, à lumière cohérente ou élément similaire et qu'elle est située dans le cadre du système de visée de l'arme à feu (11).
19. **Dispositif** selon la revendication 18, **caractérisé en ce que** les informations enregistrées dans le support logique programmable (33) peuvent être transmises via des connexions électriques, ou via un moyen de transmission qui utilise une interface hertzienne pour transmettre des informations, à un système de réception et de traitement de données et/ou peuvent être montrées sur une autre unité de visualisation différente de l'écran (21).
20. **Dispositif** selon la revendication 19, **caractérisé en ce que** le compteur (12) est équipé de différents boutons pour remettre le compteur partiel à zéro en appuyant sur l'interrupteur marche/arrêt de l'unité de visualisation ou pour prédéfinir un certain nombre sur l'unité de visualisation (21) de façon à ce que le compteur (12) décompte une unité à chaque fois que le nouveau coup est tiré.
21. **Dispositif** selon la revendication 18, **caractérisé en ce que** les informations affichées sur l'unité de visualisation peuvent être montrées avec différentes intensités de lumière pour une adaptation à l'intensité de l'éclairage ambiant.
22. **Dispositif** selon la revendication 18, **caractérisé en**

ce que l'unité de visualisation peut en outre montrer des informations relatives à la température du canon de l'arme à feu.

- 5 23. **Dispositif** selon la revendication 22, **caractérisé en ce que** la température du canon de l'arme à feu peut être montrée avec une valeur de température.
- 10 24. **Dispositif** selon la revendication 22, **caractérisé en ce que** la température du canon de l'arme à feu peut être montrée indirectement par la façon dont la valeur du compteur partiel est montrée.
- 15 25. **Arme à feu** qui comprend un dispositif selon n'importe laquelle des revendications précédentes.

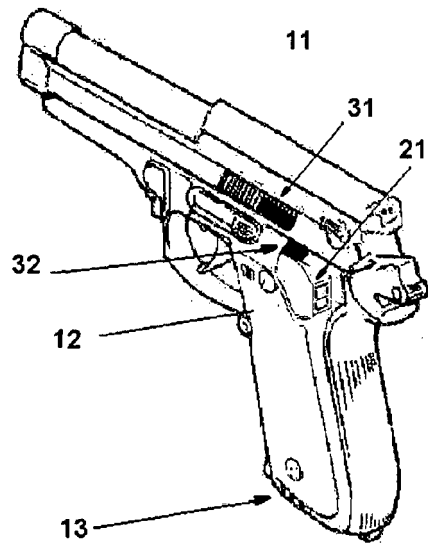

FIG. 1a

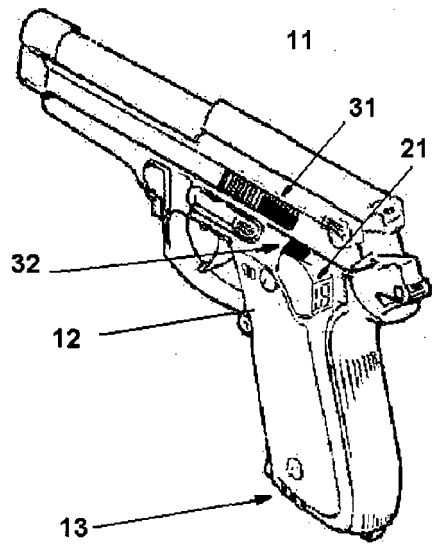

FIG 1 b

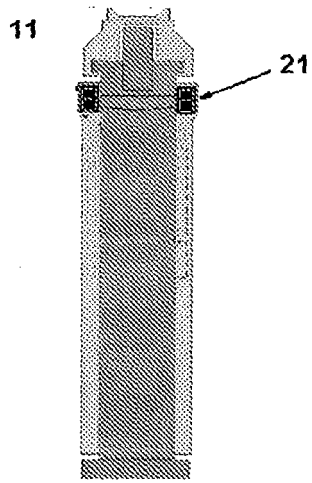

FIG. 2 a

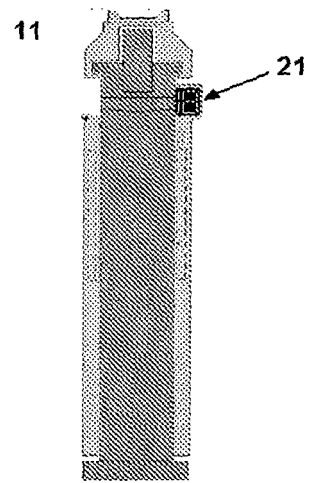

FIG. 2 b

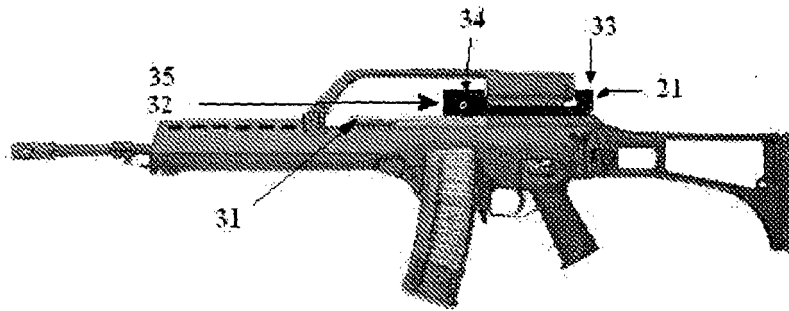

FIG. 2c

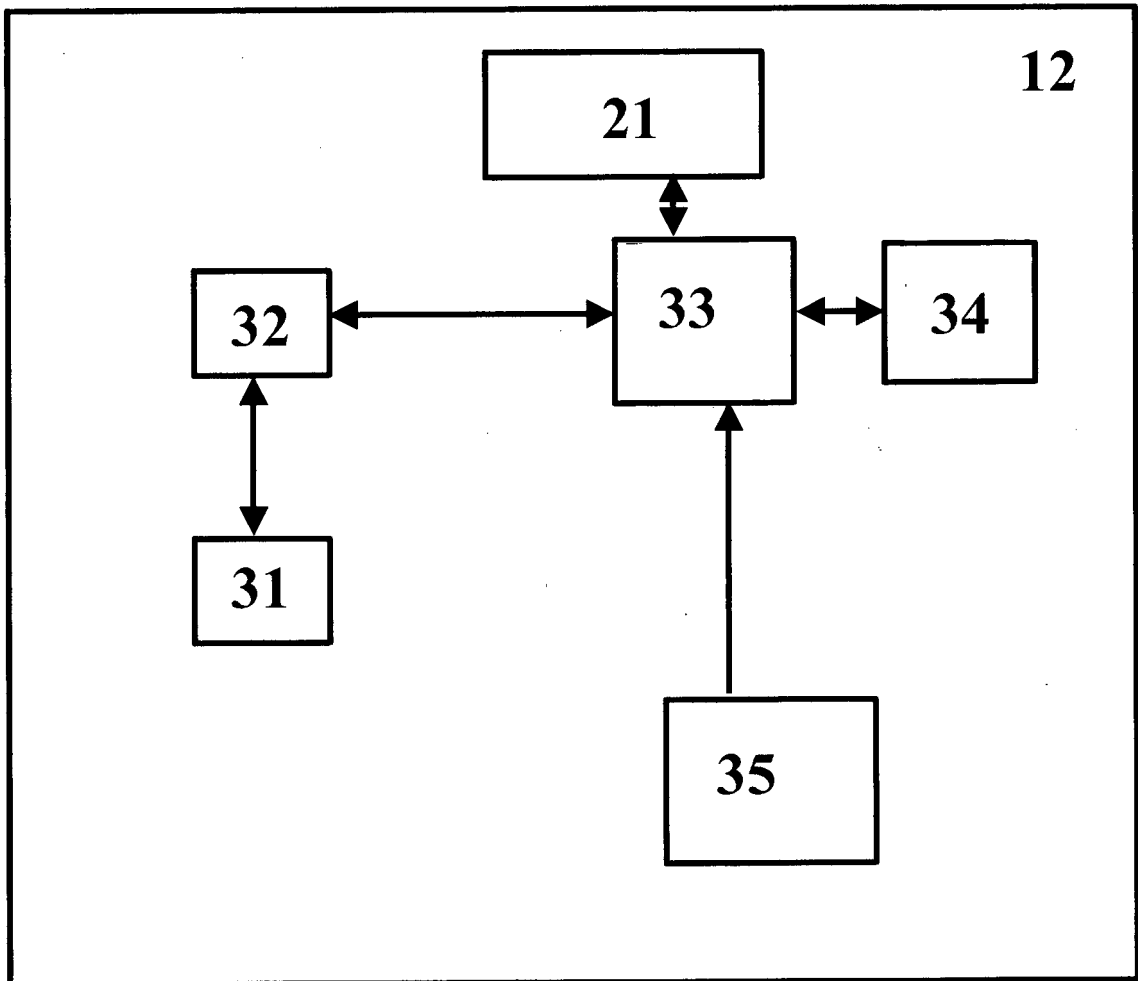

FIG. 3

REFERENCES CITED IN THE DESCRIPTION

This list of references cited by the applicant is for the reader's convenience only. It does not form part of the European patent document. Even though great care has been taken in compiling the references, errors or omissions cannot be excluded and the EPO disclaims all liability in this regard.

Patent documents cited in the description

- WO 2006042876 A1 [0004]
- EP 1574805 A1 [0004]
- US 5406730 A [0004]
- US 20050114084 A1 [0004]
- US 5142805 A [0004]