

(No Model.)

2 Sheets—Sheet 1.

P. RIBARD.
RAILWAY SIGNALING APPARATUS.

No. 522,494.

Patented July 3, 1894.

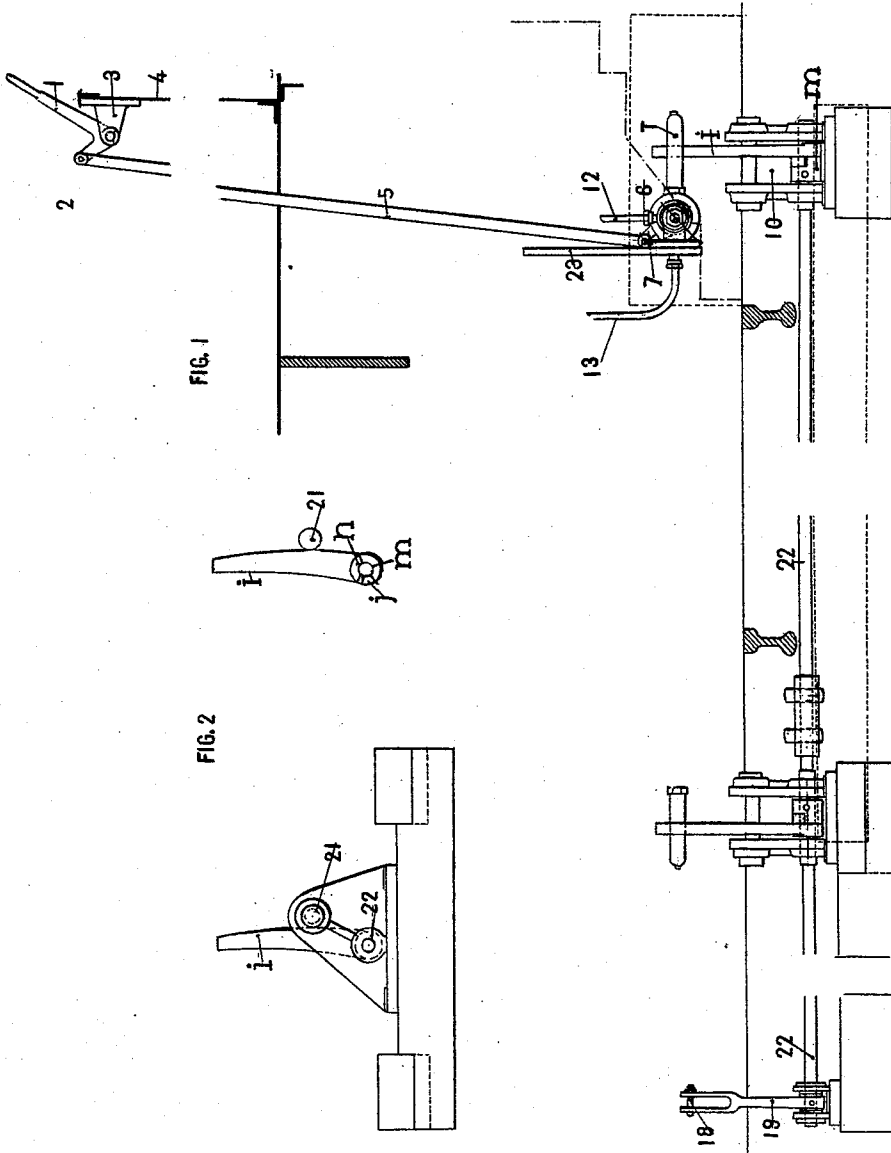

Witnesses

W. Paul
John A. Green

Inventor

Paul Ribard

by James L. Norris
Atty.

P. RIBARD.
RAILWAY SIGNALING APPARATUS.

No. 522,494.

Patented July 3, 1894.

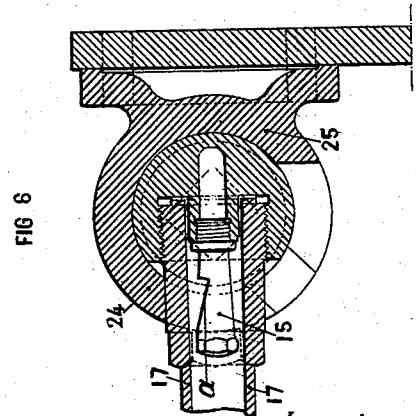
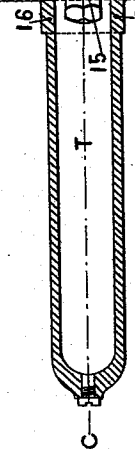
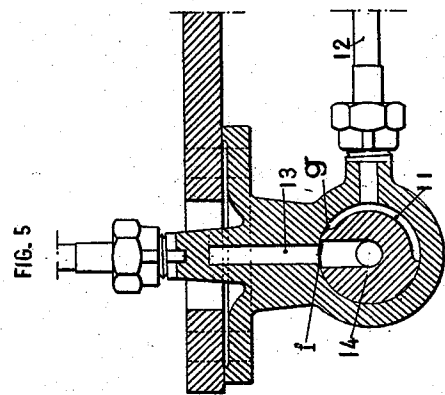
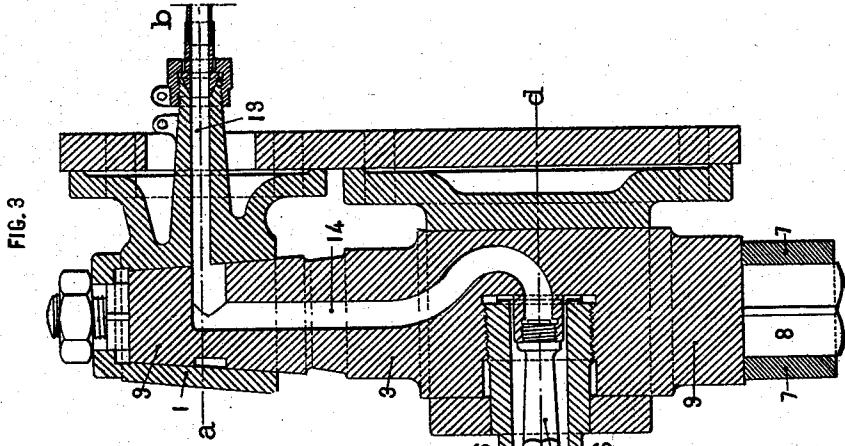
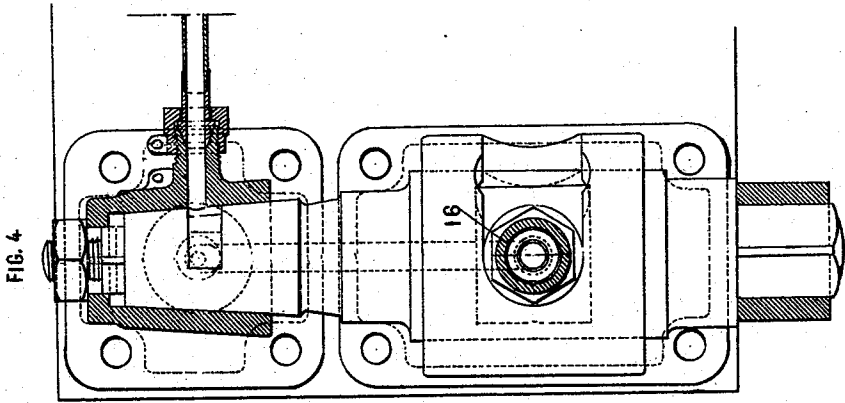

Witnesses
J. A. Paul
Thos. A. Green

Inventor
Paul Ribard
 by *James L. Norris*
Atty.

UNITED STATES PATENT OFFICE.

PAUL RIBARD, OF MARSEILLES, FRANCE.

RAILWAY SIGNALING APPARATUS.

SPECIFICATION forming part of Letters Patent No. 522,494, dated July 3, 1894.

Application filed November 28, 1893. Serial No. 491,996. (No model.)

To all whom it may concern:

Be it known that I, PAUL RIBARD, a citizen of France, and a resident of Marseilles, in the Department of the Bouches-du-Rhône, France, have invented a new and useful Improvement in Railway Signaling Apparatus, of which the following is a specification.

This invention relates to an accessory apparatus for locomotives by the action of which a continuous whistling is infallibly produced whenever a signal set at danger is passed, the said whistling being produced by the action of the engine driver such action being prescribed by the regulations or being produced automatically when from any cause the driver's attention has not been called to the warning disk or signal.

The apparatus forming the subject of this invention also has the effect of affording an indication that the engineer has neglected to pay attention to the danger signal.

In order that my said invention may be fully understood I shall now proceed more particularly to describe the same and for that purpose shall refer to the several figures on the annexed sheet of drawings the same letters and numerals of reference indicating corresponding parts in all the figures.

Figure 1 of the accompanying drawings represents the general arrangement of the apparatus part of which is attached to the locomotive the other part being stationary or fixed on the permanent way and connected as hereinafter explained with the ordinary signaling mechanism. Fig. 2 represents the stationary part in detail. Fig. 3 represents in horizontal section the tube of the whistle showing its connection with the locomotive and the passages for supplying the whistle with steam or compressed air. In this figure the tube is represented in a horizontal position being the position which it occupies regularly. Fig. 4 is a front view of the part supporting the tube viewed in a vertical plane parallel to the direction of the line. Fig. 5 represents a section taken on the line $a-b$ Fig. 3. Fig. 6 is a section on the line $c-d$ Fig. 3.

The engine driver is required to blow a whistle when on the point of passing a danger signal. For this purpose he must move the handle 1 Fig. 1 from the position 1 to the

position 2 by turning it from right to left. The handle 1 is a bell crank lever fulcrumed on a support 3 attached to the rail 4 of the locomotive. In this movement the rod 5 is compelled to descend and moves a lever 7 through a given angle (Figs. 1 and 3). This lever being fixed on the square head 8 of a plug 9 (Fig. 3) causes this plug to rotate. The plug in rotating causes the whistle tube T (Figs. 1 and 3) to move with it and withdraws it from the action of the finger I of the tube breaker 10 (Fig. 1) placed upon the line and hereinafter described.

The plug 9 is provided with a recess notch 11 (Figs. 3 and 5) destined to place in communication two steam passages 12 and 13 (Figs. 3 and 5). The passage 13 opens at a point above the surface of the water in the boiler and supplies the apparatus with steam. It is seen that when the tube is in the horizontal position (Fig. 3) that is to say in the normal position for traveling the steam from the passage 13 goes along the passage 14 formed in the plug and fills the tube T after passing through the mouth a (Fig. 6) of the whistle 15 (Figs. 6 and 3) but when the plug is manipulated in such a manner as to be rotated elevating the tube T directly the rotary motion commences and the small arc $f g$ of a circle (Fig. 5) has been described the passage 13 is placed in communication with the passage 12 and the steam is enabled to pass along this passage the outlet of which is arranged underneath the ordinary whistle or under a special whistle.

It will be seen that the engine driver is simply required to whistle on seeing the signal ahead of him otherwise the tube is broken against the tube breaking device T. This arrangement is a point of great importance as it prevents the engine driver from putting the apparatus out of action. In fact he cannot escape from the tube breaking device except by causing the whistle to sound continuously this being one of the essential features of the invention.

In case the engine driver has failed to observe the signal or, having seen it has omitted hereinbefore described the tube is inevitably broken when the engine passes before a closed signal and when this has taken place the pas-

sage through the whistle 15 being open the whistle sounds until the engine driver has performed the following operations namely: placing the lever in the position 2 thus stopping the whistle 15 and opening the whistle on the locomotive and enabling a fresh tube to be inserted in the place of the broken tube T. In order to effect this exchange the broken end of the tube is unscrewed by means of a key or spanner fitting the hexagonal part 16 (Figs. 3 and 4) on the tube and screwing home a new tube with the same key inserting if required a fresh washer to make the tight joint between the end of the tube T and the seat formed in the plug 9. The tube is so constructed that the fracture must take place at or beyond the point 17 Fig. 6 so that the whistle 15 is protected from injury. The breakage of the tube takes place when the engine is running funnel foremost by the tube breaking arm I placed on the right hand side of the track and in the case of an engine running in the same direction with the fire box end in front, by a similar arm located on the left hand side of the track and actuated at the same time as the other arm by a rod connected to the signal wire. The forked lever 19 Fig. 1 is provided with a pin 18 which can be inserted in one of the links of a chain inserted in the signal wire. The lever 19 is so arranged that when the signal is set at danger the two steel arms I of the tube breaking devices vibrating on a rock shaft 22 being free to turn upon this shaft are elevated by a projection on a sleeve *m* keyed upon this shaft. The arm I is provided with a projection corresponding with that on the sleeve *m* and which enables it to be elevated into the vertical position in which position it is supported by a rod 21 Fig. 2 connecting the two cheeks or brackets of the tube breaking device. The object of this arrangement is to prevent the reaction or effect of the blow which would be transmitted to the rock shaft and to the actuating lever 19 if the two projections *j* and *h* remained in contact. The rod 21 alone receives the shock of the tube and transmits the reaction to the ballast without acting upon the shaft 22 and disturbing the signal wire.

The arm I of the tube breaking device as well as the rod 21 are of steel. The tube is of cast iron, the plug 9 is of gun metal and the supports of the apparatus upon the engine are made of wrought iron.

The gun metal plug is combined with an iron shell constructed with a recess 24, 25 Fig. 6 provided to admit of the rotation of the tube, the ends of this recess receive the shock produced whether the tube be broken in one direction or the other. These recesses protect the screw thread by which the tube is connected to the plug from injury. This arrangement combined with the double acting tube breaking device enables the apparatus to act when the engine is running either forward or backward.

The part of the apparatus carried by the

engine is attached to the part 23 Fig. 1 of the under frame of the engine by one or more connecting plates or supports the length and shape of which are regulated according to the construction of the permanent way and of the rolling stock.

It is generally possible to find a small neutral zone between the different profiles of track adopted by different companies to enable the same form of apparatus to be employed on any track. The arm I of the tube breaking device must be arranged to be elevated within this zone.

The action of the apparatus hereinbefore described is as follows: When the locomotive approaches the signal set at danger the tube breaking arms I are elevated as represented in Fig. 1 and the engine driver at the moment when he is about to pass the signal must manipulate the lever I in such a manner as to elevate the tube T so that the latter may not be broken. This operation opens either the ordinary whistle on the locomotive or a special whistle provided for the purpose. In case the engine driver neglects to do this the tube T is broken and the whistle 15 sounds. The tube T being broken the mistake of the engine driver is disclosed and the whistle continues as hereinbefore explained until the broken tube T has been replaced. The continuous sound of the whistle is an advantage over the warning given by the explosion of fog signals which are not only liable to fail to go off but produce momentary sound which is capable of being confounded with other noises.

Having now described the object of my invention and the means for realizing the same and reserving the right to modify any of the accessory arrangements employed in practical working, I claim as my invention—

1. The locomotive signaling device hereinbefore set forth, consisting essentially of a whistle secured upon the locomotive the base of which forms a steam tight joint, the said whistle being inclosed in a fragile casing, the breakage of which by striking against an obstruction caused to project from the track enables the steam to escape through the whistle and produce an audible signal, substantially as shown and for the purpose specified.

2. A locomotive signal comprising a movable piece arranged to be rotated by the engineer, consisting of a cock provided with a recess communicating with the steam whistle or with an automatic whistling apparatus, the said recess being so arranged that upon the automatic whistle being rendered inoperative the ordinary locomotive whistle is sounded, substantially as described.

3. In the safety signaling apparatus hereinbefore described a steam supply passage and a movable device capable of being rotated by the engine driver and having a fragile or breakable end or projecting part in combination with the apparatus actuated by the ordinary signaling gear and brought into action

whenever a signal is set at danger so as to
cause an arm or obstruction to be placed in
the path of the said breakable part as and for
the purpose substantially as hereinbefore de-
5 scribed with reference to the accompanying
drawings.

4. In a locomotive signal, the combination
of a steam passage, a rotatable multiple way
cock, two whistles independently connected
10 with said steam passage and controlled by
said cock, and a frangible casing connected

with the steam passage, said whistles being
separately actuated by a hand operating de-
vice and by the breakage of the frangible cas-
ing, substantially as described.

In testimony whereof I have signed this
specification in the presence of two subscrib-
ing witnesses.

PAUL RIBARD.

Witnesses:

CLYDE SHROPSHIRE,

W. JONES.

15