

[72] Inventor **John J. Keranen**
Sussex, Wis.
[21] Appl. No. **58,944**
[22] Filed **July 28, 1970**
[45] Patented **Oct. 19, 1971**
[73] Assignee **Cutler-Hammer, Inc.**
Milwaukee, Wis.

[56]		References Cited	
UNITED STATES PATENTS			
3,435,169	3/1969	Bienwald et al.	200/167 A
3,301,988	1/1967	Weitzman	200/167 A
3,294,945	12/1966	McLaughlin	200/167 A
3,409,751	11/1968	Krieger	200/167 A

Primary Examiner—H. O. Jones
Attorneys—Hugh R. Rather and William A. Autio

[54] **LIGHTED TOGGLE LEVER SWITCH**
10 Claims, 5 Drawing Figs.

[52] U.S. Cl.....	200/167 A, 200/172 A
[51] Int. Cl.....	H01h 9/18
[50] Field of Search.....	200/167 A, 172 A

ABSTRACT: A switch having a toggle lever including a snap-on transparent, hollow handle with a lamp inside connected to external terminals. These lamp terminals differ in appearance and location from the external terminals connected to the switch. The handle portion of the toggle lever is easily removable to expose the bulb for replacement in the socket built into the toggle lever. A pair of helical springs positioned at the axis of rotation of the toggle lever form electrical connections from the lamp socket to the external, lamp terminals.

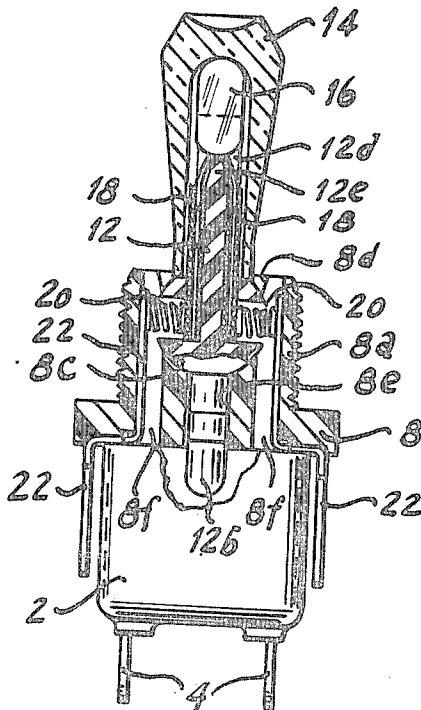

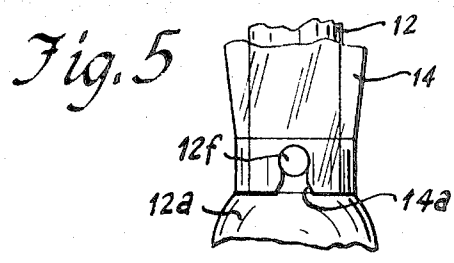
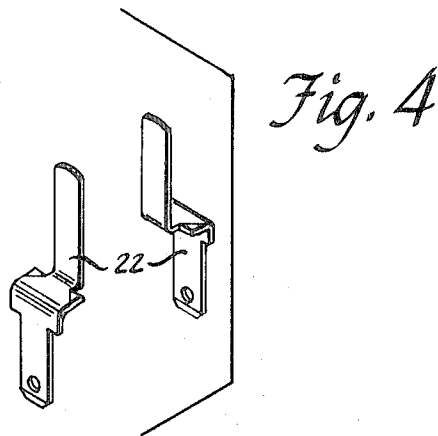
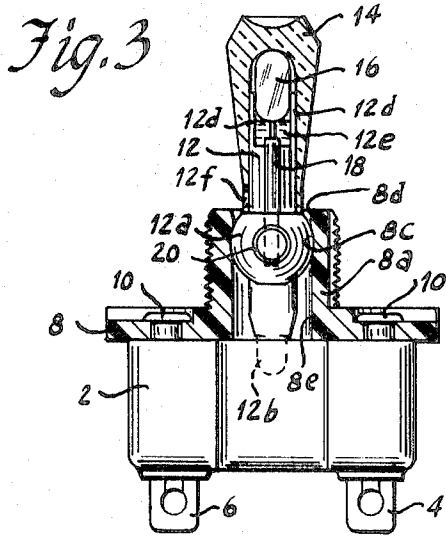
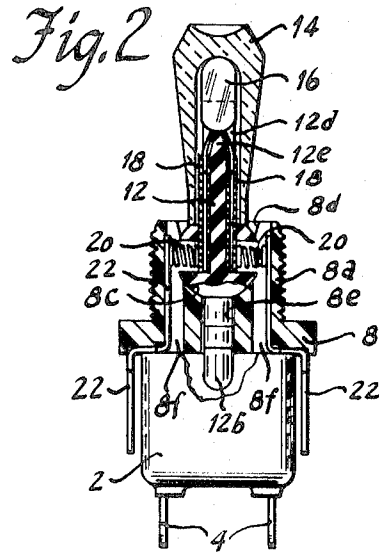
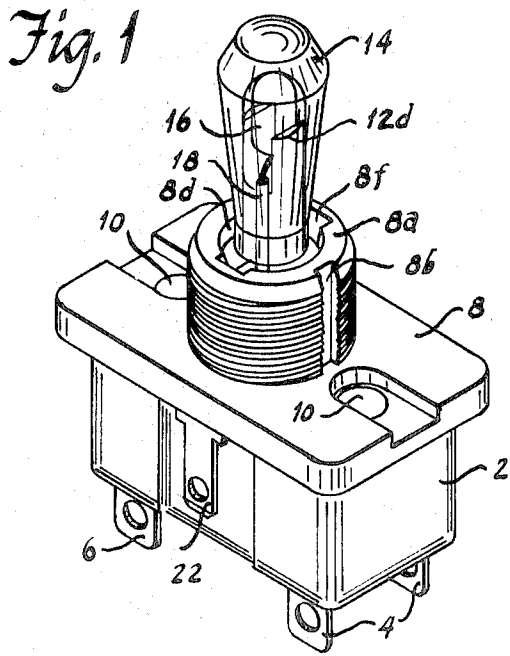

Inventor
John J. Keranen
By *Thos. A. Antis*
Attorney

LIGHTED TOGGLE LEVER SWITCH

BACKGROUND OF THE INVENTION

Lighted toggle lever switches have been known heretofore. However, difficulties have been encountered in these prior switches in that the lamp bulb has been either not replaceable or very difficult to replace, requiring substantial disassembly of the switch. Also, such prior switches have used flexible leads or the like for commutating the current to the lamp in the pivoted handle, with their probability of failure due to repeated bending when the switch is used.

This invention relates to improvements in the lighted toggle lever switch art that overcome the aforementioned disadvantages.

SUMMARY OF THE INVENTION

This invention relates to replaceable bulb lighted toggle lever switches.

An object of the invention is to provide an improved lighted toggle lever switch.

A more specific object of the invention is to provide improved means for mounting an indicator lamp within the handle of a toggle lever switch affording secure mounting and easy replacement of the lamp bulb.

Another specific object of the invention is to provide a lighted toggle lever switch with an improved snap-it handle on the toggle lever affording replacement of the lamp bulb mounted therewithin.

Another specific object of the invention is to provide a lighted toggle lever switch with improved electrical connector means for commutating current from the terminals in the switch base to the lamp bulb in the oscillatable handle.

Another specific object of the invention is to provide a lighted toggle lever switch with improved lamp connector means operating at the axis of rotation of the toggle lever to reduce wear.

Other objects and advantages of the invention will hereinafter appear.

BRIEF DESCRIPTION OF THE DRAWINGS

FIG. 1 is an enlarged isometric view of a lighted toggle lever switch constructed in accordance with the invention;

FIG. 2 is an end view of the switch of FIG. 1 with the upper portion including the toggle lever and cover shown in section in the plane of the pivotal axis;

FIG. 3 is a front view of the switch of FIG. 1 with the upper portion including the toggle lever and cover shown in section transverse to the plane of the pivotal axis;

FIG. 4 is an isometric view of the lamp terminals of the switch of FIGS. 1-3; and

FIG. 5 is an enlarged fragmentary view of the snap-fit portions of the handle and toggle lever also shown in FIG. 3.

DESCRIPTION OF THE PREFERRED EMBODIMENT

Referring to FIG. 1, there is shown a switch according to the invention that may have, for example, a single-pole double-throw switch action. This switch is provided with an insulating base 2 housing the switch contacts.

In the single-pole double-throw version illustrated, two pairs of switch terminals 4 and 6 extend out through the bottom of the base for connection to an external circuit. These terminals are integral with or connected to stationary contacts within the base. The contacts of the two pairs thereof are alternately bridged by a movable bridging contact when the toggle lever is oscillated between its two operating positions. For example, the bridging contact may be a pivoted U-shaped member operated through a compression spring from the toggle lever to provide snap-action closing or opening of the contacts. Switch contacts of this type are known in the art and reference may be had to A. W. Krieger U.S. Pat. No. 1,998,962, dated Apr. 23, 1935, for an illustration and description thereof.

As shown in FIG. 1, the open top of the base is closed by an insulating cover 3 that is rigidly secured to the base by a pair of rivets 10 or the like to provide a switch housing. Integrally formed with the cover, an externally threaded bushing 8a extends up from the center thereof and is provided with a keyway 8b along one side thereof for nonrotatably holding a keyed washer when a nut is threaded thereon to mount the switch to a panel.

As shown in FIGS. 2 and 3, the inside of the bushing is provided with a suitable configuration for snap-in mounting of a toggle lever 12 and for pivotally retaining the toggle lever for movement in the plane of FIG. 3 without allowing it to wobble transverse from its proper plane of movement. For this purpose, the bushing has molded therein a socket 8c for the spherical portion 12a of the toggle lever. The upper sides of this socket diverge to the top of the bushing to form a frustoconical opening 8d through which the spherical portion of the toggle lever may be snapped into its pivotal seat. The lower portion of the bushing below the spherical socket is provided with a reduced opening 8e oblong in cross section to guide the lower end portion 12b of the toggle lever in the plane of its movement.

As shown in FIGS. 2 and 3, the reduced lower end portion 12b of the toggle lever extends part way down into the upper portion of the base and is adapted to engage the upper end of a toggle-action compression spring or the like for obtaining snap-action of the movable contact when the handle is actuated.

As shown in FIGS. 2, 3 and 5, toggle lever 12 has mounted thereon a snap-in transparent or translucent removable hollow handle 14 covering a lamp bulb 16.

The upper end of this toggle lever 12 is provided with a lamp socket. For this purpose, this upper end is formed with a pair of spaced, flat upward projections 12d connected by a narrow web 12e as best shown in FIG. 3 to provide a seat for the lamp bulb. A pair of small-diameter holes extend down through this upper end, one on each side of the narrow web, and terminate in lateral holes extending in opposite directions in spherical portion 12a on the axis of rotation thereof. A pair of small-diameter connector or conductor tubes 18 extend through the two small-diameter holes for receiving the two lamp bulb leads. A pair of resilient connectors such as helical compression springs 20 extend through the lateral holes and are compressed between conductor tubes 18 and lamp terminals 22, respectively.

As shown in FIGS. 1 and 2, bushing 8a is provided with two vertical openings 3f therethrough, one on each side, communicating with the lower and upper ends of the bushing and with the lateral holes in the spherical portion of the toggle lever. Thus, a pair of lamp terminals may be inserted up through the respective openings slightly past the lateral openings so that connector springs 20 bear thereagainst and electrically connect the lamp conductor tubes thereto. These lamp terminals are formed with an offset at about the midpoint as shown in FIGS. 2 and 4 so that they extend laterally out between cover 3 and the upper edges of the base. These lamp terminals extend down in spaced-apart relation to the walls of the base so that suitable complementary terminals can be secured thereon.

The transparent removable handle is provided with a snap-in connection to the toggle lever as shown in FIGS. 3 and 4. For this purpose, the lower end of the handle is provided with a gripper 14a consisting of a round hole connected by a slightly narrower slot to the lower edge of the handle. The toggle lever is provided with a round bead about the size of the hole in the handle. As will be apparent, when the handle is pressed onto the toggle lever, the sides of the slot will spread to allow the bead to snap into the hole to retain the handle on the toggle lever.

From the foregoing, it will be apparent that the switch may be readily assembled. To this end, connector springs 20 are first inserted into the lateral holes in the toggle lever and held in compression clear of the bushing walls by a suitable tool or

jig while the toggle lever is forced down into the bushing. The lamp terminals are then inserted into their openings from below while the connector springs are held compressed. The compression tool may then be extracted to allow the connector springs to expand against lamp terminals 22 thereby to connect lamp socket tubes 18 to the lamp terminals.

The lamp bulb leads may be inserted down into the upper ends of socket tubes 18 whereafter handle 14 is pushed onto the toggle lever over the lamp bulb and snapped into secure connection. This may be done either before or after the toggle lever is assembled in the bushing

While socket tubes 18 have been illustrated as tubular in form, it will be apparent that they could be split tubes or closely wound helical springs or the like. The electric current commutation means is subjected to minimum wear by using compression springs as connectors and placing these springs on the axis of rotation of the toggle lever where the motion is the least. The lamp bulb is arranged to fit snugly within the hole in the handle to minimize shock and bounce of the filaments therein when the switch is operated.

While the structures hereinbefore described are effectively adapted to fulfill the objects stated, it is to be understood that the invention is not intended to be confined to the particular preferred embodiment of lighted toggle lever switch disclosed, inasmuch as it is susceptible of various modifications without departing from the scope of the appended claims.

I claim:

1. In a switch having a housing enclosing contacts, the combination comprising:
 - A bushing at the top of the housing;
 - A toggle lever extending through said bushing and pivotally mounted therein for operating the contacts;
 - A lamp bulb on the outer part of the toggle lever and having a pair of connector leads;
 - A pair of conductors extending down through a portion of the toggle lever to its pivotal axis area forming a lamp socket adapted to receive the lamp bulb leads,
 - a pair of lateral holes extending in opposite directions from the respective conductors at first ends of these holes out through the opposite sides of the toggle lever on the axis of rotation thereof;
 - a pair of lamp terminals extending up through the bushing to be exposed at the other ends of said holes, respectively,
 - a pair of resilient connectors in said lateral holes between said conductors and said lamp terminals, respectively, to complete the electrical connections from said lamp terminals to said lamp bulb;
 - and a hollow removable handle SNAP-in fitted to the toggle lever over said lamp bulb and comprising light-passing material to indicate when the lamp bulb is lit.
2. The invention defined in claim 1, wherein:
 - said toggle lever comprises a substantially spherical enlarged portion about its axis of rotation into which said conductors extend to be exposed in said lateral holes;
 - and said bushing comprises a substantially spherical complementary recess having a slightly constricted opening thereinto through which said toggle lever enlarged portion is snapped thereby to mount said toggle lever for rocking movement in said recess.
3. The invention defined in claim 2, wherein said bushing comprises:
 - a pair of narrow openings extending through said bushing and communicating with the respective spherical complementary recesses therein for receiving the respective lamp terminals from one end and for receiving the respective resilient connectors from their other end when said

toggle lever is pressed into said bushing.

4. The invention defined in claim 1, wherein said pair of resilient connectors comprise:
 - a pair of helical springs compressed between the respective conductors and lamp terminals.
5. The invention defined in claim 1, wherein said pair of conductors comprise:
 - a pair of small-diameter tubular metal members extending through a pair of small holes in said toggle lever.
6. The invention defined in claim 1, wherein said pair of lamp terminals comprise:
 - a pair of flat metal strips each offset at the center so that one end extends into said bushing, the middle part extends laterally out from said housing, and the other end thereof extends in spaced parallel relation to a wall of said housing.
7. An electric switch comprising:
 - a housing enclosing switch contacts and including switch terminals extending through a wall of the housing adapted to be connected to an external circuit;
 - a bushing extending from said housing;
 - a toggle lever extending through said bushing for operating said contacts;
 - pivotal mounting means for said toggle lever within said bushing;
 - a lamp bulb on the external part of said toggle lever having a pair of bare connector leads;
 - a pair of conductors extending from the lamp bulb through said toggle lever to its pivotal area adapted to receive said lamp bulb leads;
 - a pair of lateral recesses opening in opposite directions from the respective conductors through the opposite sides of the toggle lever on the axis of rotation thereof;
 - a pair of lamp terminals extending from said housing part way through said bushing into the area of said lateral recesses
 - a pair of spring connectors in said lateral recesses and normally extending out in opposite directions therefrom requiring compression thereof into said recesses to enable insertion of the toggle lever in said bushing and allowing expansion thereof against said conductors and said lamp terminals, respectively, to afford electrical connections therebetween;
 - and a hollow light-transmitting handle snap-in fitted to the external part of said toggle lever over said lamp bulb to afford a visual indication of the lighted condition of the lamp bulb.
8. The invention defined in claim 7, wherein said pivotal mounting means comprises:
 - a generally spherical enlarged portion on said toggle lever having said recesses therein;
 - and a generally spherical complementary socket in said bushing in which said enlarged portion of said toggle lever is seated for pivotal movement.
9. The invention defined in claim 7, wherein said pair of lamp terminals comprise:
 - a pair of flat conductive strips each offset at the middle so that one straight end extends into said bushing, the middle part extends through a wall of said housing, and the other straight end is in spaced parallel relation with a wall of said housing and is readily distinguishable in appearance from said switch terminals.
10. The invention defined in claim 7, wherein said snap-in fitting between the handle and toggle lever comprises:
 - means affording easy removable of said handle for bulb replacement.