



INTERNATIONAL APPLICATION PUBLISHED UNDER THE PATENT COOPERATION TREATY (PCT)

<p>(51) International Patent Classification ⁶ : F16K 5/00, 47/02, 47/08</p>	<p>A1</p>	<p>(11) International Publication Number: WO 99/05437 (43) International Publication Date: 4 February 1999 (04.02.99)</p>
<p>(21) International Application Number: PCT/US98/15203 (22) International Filing Date: 22 July 1998 (22.07.98) (30) Priority Data: TO97A000671 25 July 1997 (25.07.97) IT (71) Applicant (for all designated States except US): MASCO CORPORATION [US/US]; 21001 Van Born Road, Taylor, MI 48180 (US). (72) Inventor; and (75) Inventor/Applicant (for US only): KNAPP, Francesco [DE/IT]; Via Giacomo Leopardi, 28, I-27061 Cava Manara (IT). (74) Agent: PERMUT, Steven, L.; Reising, Ethington, Learman & McCulloch, P.O. Box 4390, Troy, MI 48099 (US).</p>	<p>(81) Designated States: CA, JP, MX, RU, TR, US, European patent (AT, BE, CH, CY, DE, DK, ES, FI, FR, GB, GR, IE, IT, LU, MC, NL, PT, SE). Published <i>With international search report.</i></p>	

(54) Title: IMPROVED STEM VALVE STOPPER

(57) Abstract

A stem valve stopper that has a shell (1) intended to be mounted to the body of a cock, tap or faucet. A mobile fitting (6) is mounted in the shell so that it can be moved axially and so that it cannot be turned or rotated inside the stopper shell and carries a valve seal (13). An operating stem (8) is mounted for rotation, but is axially fixed in the stopper shell. The stem has one end inside the shell that is threadably engaged with the mobile fitting, and an outer end (8) protruding from the shell of the stopper and constructed to receive an operating handle. The valve seal, supported by the mobile fitting of the stopper is made up of an elastomeric material. A collar (10) is made of rigid material and is mounted in the stopper shell. The collar has a valve seat at one end and is seated on the other opposite end about a passage (p) of the cock, tap and/or faucet. The valve seat is made of elastomeric material and preferably inside its retaining regions has a hollow space so that, in the closed mode, it is dilated by the pressure of the water to press against the valve seat.

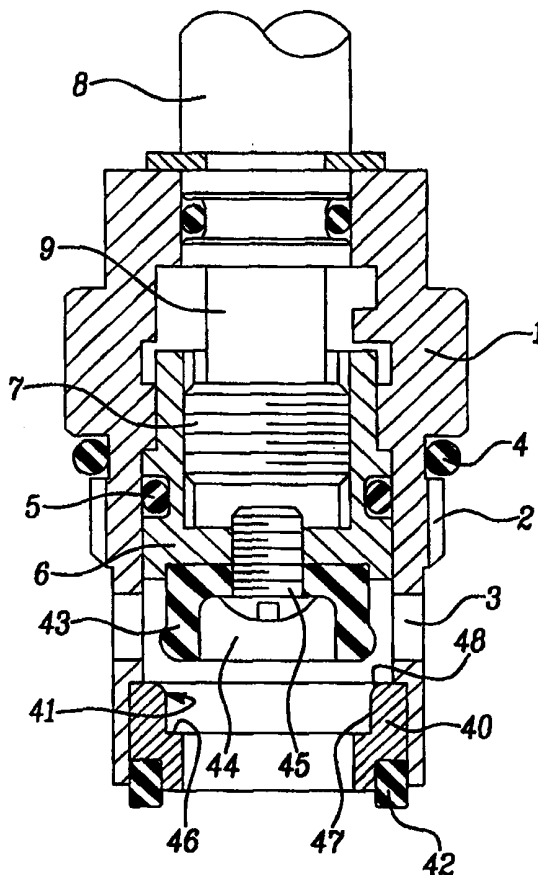

FOR THE PURPOSES OF INFORMATION ONLY

Codes used to identify States party to the PCT on the front pages of pamphlets publishing international applications under the PCT.

AL	Albania	ES	Spain	LS	Lesotho	SI	Slovenia
AM	Armenia	FI	Finland	LT	Lithuania	SK	Slovakia
AT	Austria	FR	France	LU	Luxembourg	SN	Senegal
AU	Australia	GA	Gabon	LV	Latvia	SZ	Swaziland
AZ	Azerbaijan	GB	United Kingdom	MC	Monaco	TD	Chad
BA	Bosnia and Herzegovina	GE	Georgia	MD	Republic of Moldova	TG	Togo
BB	Barbados	GH	Ghana	MG	Madagascar	TJ	Tajikistan
BE	Belgium	GN	Guinea	MK	The former Yugoslav Republic of Macedonia	TM	Turkmenistan
BF	Burkina Faso	GR	Greece			TR	Turkey
BG	Bulgaria	HU	Hungary	ML	Mali	TT	Trinidad and Tobago
BJ	Benin	IE	Ireland	MN	Mongolia	UA	Ukraine
BR	Brazil	IL	Israel	MR	Mauritania	UG	Uganda
BY	Belarus	IS	Iceland	MW	Malawi	US	United States of America
CA	Canada	IT	Italy	MX	Mexico	UZ	Uzbekistan
CF	Central African Republic	JP	Japan	NE	Niger	VN	Viet Nam
CG	Congo	KE	Kenya	NL	Netherlands	YU	Yugoslavia
CH	Switzerland	KG	Kyrgyzstan	NO	Norway	ZW	Zimbabwe
CI	Côte d'Ivoire	KP	Democratic People's Republic of Korea	NZ	New Zealand		
CM	Cameroon			PL	Poland		
CN	China	KR	Republic of Korea	PT	Portugal		
CU	Cuba	KZ	Kazakstan	RO	Romania		
CZ	Czech Republic	LC	Saint Lucia	RU	Russian Federation		
DE	Germany	LI	Liechtenstein	SD	Sudan		
DK	Denmark	LK	Sri Lanka	SE	Sweden		
EE	Estonia	LR	Liberia	SG	Singapore		

IMPROVED STEM VALVE STOPPER

TECHNICAL FIELD

This invention relates to a stopper of the rotating screw type,
intended to be applied to a cock, tap or valve to adjust the flow of water between an
5 intake passage and an outlet passage.

BACKGROUND OF THE INVENTION

Rotating screw stoppers have long been used to control the flow
through a tap or faucet. The screw has an exterior end mounted to a handle. The
10 screw is threadably engaged to a housing and mounting a mobile valve seal or
washer at the interior end.

As the screw valve is tightened, the washer is compressed against
a valve seat. However, the washer by being rotated as it compressed against the
valve seat until the stem was fully tightened unduly wore both the washer and the
15 valve seat. While the washer could be replaced, the valve seat could not.

Furthermore, the stem rose out of the housing as the valve was opened which
many users deemed undesirable. Non-rising stem valves have been developed
that use shearing action of a valve seal. Compressive valves are often still
desirable due to the greater sealing forces available through compression. More
20 rising stem valves have been developed that continue to use compressive action
of the seal against a fixed valve seat.

A non-rising stem stopper essentially comprises a shell, intended to

be affixed securely to the body of a cock, tap or valve. A mobile fitting is mounted in an axially movable manner and in a nonrotatable manner inside the shell of the stopper and bearing a valve seal. An operating stem is mounted for rotation and fixed in an axial direction in the shell of the stopper. The stem has one end inside
5 the shell, linked by a screw threading to the mobile fitting, and an outer end that protrudes from the shell of the stopper and constructed to mount an operating handle. Rotation of the handle causes axial shifting of the mobile fitting and the valve seal which, cooperating in a timely fashion with a valve seat placed between the intake passage and the outlet passage of the shell of a cock, tap or valve brings
10 about the desired adjustment of the water flow.

Traditionally, the valve seal, supported by the mobile fitting, was made up of a packing disc consisting of elastomeric material. The mouth of the inlet passage is formed in the shell of a cock, tap or valve, itself as a valve seat that cooperates with the packing disc to adjust the flow. An example of this traditional
15 arrangement is provided in document DE-U-94 18 554.

With this arrangement, a sealing washer made of elastomeric material was subject to deterioration. After deterioration, the washer can be easily removed by dismantling the shell of the stopper from the body of the set of cocks, taps and valves. Furthermore, the repair was inexpensive. A simple washer with a
20 central hole was attached via a bolt.

However, the valve seat that cooperates with this washer is also subjected to deterioration. Due to the valve seat being a part of the body of a cock,

tap or valve, it can be restored only by working on it with a suitable manual milling machine. Such a repair is not an easy operation nor are the results always satisfactory and the repair cannot be repeated more than several times.

An attempt was therefore undertaken to make this valve seat on an
5 separate member that is screwed into the body of the cock, tap or valve and that can be extracted so that it may be repaired or replaced. Such a modification results in an excessive increase in the cost of the cock, tap or valve. Furthermore, the operations involved in disassembling and reassembling the applied valve seat are not easy and require special tools.

10 An attempt was made to remedy this inconvenience, for example, as disclosed in document EP-B-0 606 419. In this disclosure, the valve seal is a rigid element forming a part of the mobile fitting of the stopper. A special packing made of elastomeric material installed in the shell itself fits tightly against the mouth of the intake passage presented by the body of a cock, tap or valve and which, will
15 cooperate with the rigid valve seal presented by the mobile fitting of the stopper. The body of the cock, tap or valve is thus protected against any deterioration; but the special necessary packing must have a complex configuration and is therefore expensive. The shell of the stopper itself also requires relatively expensive processing to manufacture a seat intended to receive such a packing.

20 In view of the above, it is desired to have a non-rising stem valve stopper that protects the body of the cock, tap or valve against any deterioration without, however, requiring the use of a packing with an excessively complicated

shape and without the need for any expensive work on the body that houses the stopper. What is also desired is a valve stopper that enables the designer of the stopper a great degree of freedom in the choice of the configuration of the valve seal. It is further desired to introduce a flow-splitter that reduces the noise

5 connected with the tapping of small volumes of water into the stopper. It is further desired to facilitate the spontaneous adaptation of the tight holding conditions of the valve seal in response to the effective pressure of the flow, which it is expected to control.

SUMMARY OF THE DISCLOSURE

10 In accordance with one embodiment of the invention, a valve seal is supported on a mobile fitting of a stopper. The valve seal preferably includes a valve packing made of elastomeric material mounted on an operating stem. The stem extends out of one end of a shell. In addition, a collar made of rigid material is mounted at an opposite end of the shell of the stopper. The collar, on one side

15 forms a valve seat that cooperates with the valve seal. The opposite side of the collar carries a static packing or seal to sealingly fit about the mouth of the inlet passage presented by the body of the cock, tap or valve.

The valve seal of the stopper made up of a valve packing of elastomeric material cooperates with the valve seat presented by the collar.

20 Because both the valve seal and collar are mounted in the stopper, both the operating elements for flow regulation subject to deterioration namely, the valve seal and valve seat can be easily repaired or replaced by extracting the stopper from

the body of the cock, tap or valve. The mouth of the inlet passage in the body of the cock, tap or valve is thus protected against any action that might cause it to deteriorate, because it cooperates only with a static seal. The static seal is not subject to any appreciable deterioration because of its static nature, and
5 nevertheless, it can also be easily replaced since it is attached to the removable stopper. Furthermore, the collar that provides the valve seat may be made of a relatively hard material that is particularly resistant to deterioration, without entailing any major expenditure in view of the small mass of the collar itself.

Both the valve seal and the valve seat can without any difficulty be
10 made in various shapes, based on preference of the designer or for easier manufacture or adaption of the stopper to particular requirements. The valve seal packing that is made of elastomeric material can be a unit that is appropriately stamped for this purpose, or it can also be a packing of the commercial type, such as an O-ring or an annular disc washer. For its part, the static seal can also be given
15 various shapes and can be a unit that is appropriately stamped for this purpose, or it can also be a packing of the commercial type, such as an O-ring or a ring-shaped packing with a rectangular cross-section.

Preferably, the valve seal packing made of elastomeric material presents a hollow space so that when in the closed mode, the valve seal packing
20 can be dilated by the pressure of the water against the valve seat. In this way, the holding action of the valve seal against the valve seat is automatically proportional to the effective pressure of the liquid flow to be adjusted.

It is advantageous for the valve seat to have a substantially frusto-conical configuration. The frusto-conical shape diverges downstream so as to direct the flow toward the periphery of the stopper where the outlet passages in the stopper are located. Furthermore, this configuration ensures correct positioning
5 between the valve seal and the valve seat in spite of any eccentricity between the two elements. The frusto-conical configuration causes their spontaneous alignment and gives rise to an effective closing pressure. As an alternative, the valve seal packing can have a substantially bell-shaped configuration and can cooperate with a substantially cylindrical valve seat with a stepped flare mouth.

10 In accordance with another aspect of the invention, a toothed surface, forming a breakwater, capable of slowing down and containing the flow under severe throttle or choking conditions is positioned immediately downstream from valve seat in the direction of flow thus reducing the noise. This toothed surface can be a part of the shell of the stopper or of the collar that provides the
15 valve seat. Alternatively, the toothed surface can be formed in a separate member and it can be constructed to complement various shapes of the valve seat and the valve seal. It is desirably matched with a frusto-conical valve seat.

BRIEF DESCRIPTION OF THE DRAWINGS

Reference is now made to the accompanying drawings in which:

20 Figure 1 is a side elevational and segmented view of a valve stopper according to a first embodiment of the invention;

Figures 2 and 3 analogously illustrate two modified embodiments of the

invention with modified configurations of the valve seal and the valve seat;

Figure 4 analogously illustrates another embodiment of the invention in the open position;

Figure 5 is a view similar to Figure 4 showing the stop valve in the closed
5 position;

Figure 6 partly illustrates a variant of the valve seal illustrated in Figures 4 and 5;

Figure 7 illustrates a preferred shape of the valve seat and the valve seal having frusto-conical shapes for the operationally active sealing sections;

10 Figure 8 analogously represents another embodiment of the valve stopper according to the invention including a noise reducer in the open position;

Figure 9 is an view similar to Figure 8 showing the valve in the closed position; and

15 Figure 10 illustrates a cross-sectional profile along line X-X in Figure 8.

DETAILED DESCRIPTION OF THE PREFERRED EMBODIMENT

Referring now to Figure 1, a stem valve stopper comprises a shell 1 provided with a exterior screw threading 2 for its connection to the body of a cock, tap or faucet (of which the drawing for reasons of clarity only shows the
20 region presenting mouth K of passage P for water intake). The stopper also has peripheral openings 3 for the discharge of water, and a packing 4 to create a tight hold with the body of a cock, tap or faucet. The shell 1 houses a mobile fitting 6

mounted so as to be non-rotatably moved in the axial direction. A packing 5 establishes the seal between shell 1 and mobile fitting 6. In shell 1, there is also housed an operating stem 9. The stem 9 is mounted for rotation but is affixed in the axial direction. Stem 9 has a threaded internal end 7 that is screwed into a
5 corresponding screw threading 14 of mobile fitting 6 and has an outer end 8 that protrudes from shell 1 and is so arranged as to receive an operating handle (not shown). All of the parts described so far are commonly found in a variety of stem valve and are well known. When operating shaft 9 is rotated by means of a
10 handle, the mobile fitting is shifted axially up and down.

10 In the traditional designs, mobile fitting 6 bears a disc-shaped elastomeric packing that functions as a valve element cooperating directly with mouth K of the faucet body. The mouth K acts as the valve seat of intake passage P of the body of the cock, tap or faucet which causes the previously described
15 inconvenience and expense.

15 As shown in Figure 1, a collar 10 made of rigid material is installed in the end of shell 1 that is opposite to operating stem 9. The collar 10 has one end turned toward mobile fitting 6, forming a valve seat 11. The valve seat 11 has an annular shape with an arched cross-section. On the opposite side, collar 10 bears a static packing 12 intended to provide a tight hold against mouth K of intake
20 passage P for the water from the body of the cock, tap or faucet. A passage 15 passes through collar 10. Opposite valve seat 11, mobile fitting 6 mounts a valve seal that includes a valve packing 13 made of elastomeric material.

When the stopper is in the position shown in Figure 1, the water coming from the intake passage P, passes through passage 15 in the collar 10 which is sealed about mouth K and then between valve seat 11 and valve packing 13 and reaches openings 3 through which the liquid enters into the body of the cock, tap or faucet and is then drawn from it. When one operates stem shaft 9 to shut off the faucet, mobile fitting 6 is axially shifted toward collar 10; thereby reducing the free passage offered to the water which in turn regulates the volume, until the stopper is finally closed, which completely stops the flow.

The parts subject to deterioration are primarily the valve packing 13 and, secondarily, valve seat 11. Both of these parts can be reached easily for repair or replacement by unscrewing shell 1 of the stopper from the body of the cock, tap or faucet. Static packing 12 is not generally subject to deterioration, although it is also easily reached. In turn, mouth K of intake passage P of the body of the cock, tap or faucet is not subject to any deterioration.

As is noted, the shape of valve packing is simple and, as the case may be, it can also have the traditional shape of a centrally apertured washer attached by means of a bolt. In turn, collar 10, which does not have any large mass, can also be made without any excessive increase in cost by using a relatively hard material that will be different from the material of shell 1 in order to prevent or substantially reduce deterioration of valve seat 11.

Figure 2 illustrates an embodiment with modified construction of the collar, the valve packing, and the static valve. In this figure and in the following

figures, the same parts or parts corresponding to those described with relation to Figure 1 have the same reference numbers and are not described any further. In this case, collar 20 includes a valve seat 21 that is substantially flared with a curved surface. Valve packing 23 is shaped in a correspondingly converging curved fashion. In this embodiment, static packing 22 has a rectangular cross-section and receives a shoulder of collar 20 in an annular recess 25.

In the embodiment illustrated in Figure 3, collar 30 includes a frusto-conical valve seat 31 and bears a static packing 32 in the shape of an O-ring. In turn, valve packing 33 is in this case likewise made up of an O-ring mounted on a shoulder end 36 of fitting 6.

Figures 4 and 5 illustrate an embodiment incorporating a very advantageous feature of a pressure responsive seal. Valve packing 43 is shaped inside its holding regions to present a hollow space 44 so that it has a substantially bell-shaped configuration. Valve packing 43 is attached to mobile fitting 6 by means of a bolt 5. Valve seat 41 on collar 40 has a substantially stepped shoulder 48 and cylindrical section 47 with a tapered mouth end 48. Static packing 42 has an annular shape with a rectangular cross-section.

In the full open position as illustrated in Figure 4 and in the other partially opened positions slightly shifted with respect to it, the operation of the stopper does not present any difference with respect to what was described earlier. But when the stopper is in the closed position as illustrated in Figure 5, the pressure of the water coming from the intake of the faucet acts in space 44 of valve packing

43 and tends to cause it to expand radially with a force depending on the water pressure. Therefore, valve packing 43 which by itself can be inserted in valve seat 41 with a slight force, when in the closed position is pushed into contact with the valve seat cylindrical section 47 with a force that is dependent or
5 proportional to the water pressure. Thus, a closure seal with a force in proportion to the pressure to be overcome is accomplished in a reliable manner.

The embodiment illustrated in Figure 6 differs from the previously described embodiment only by virtue of the proportion and shape of valve packing 43. Here, the effective sealing pressure on the element 43 can be varied
10 as desired. In the present embodiment, the sealing pressure is less intensive than in the embodiment illustrated in Figures 4 and 5 due to the shallowness of space 44 inside valve packing 43.

Figure 7 illustrates an embodiment in which collar 50 includes a frusto-conical valve seat. Valve packing 53 is also configured accordingly to have an
15 active frusto-conical sealing section and an internal space 54 that causes the previously described radial dilation due to water pressure. These frusto-conical configurations offer the advantage of directing the flow when it is considerably choked radially outward and directed to outlet opening 3. Furthermore, these configurations also ensure correct cooperation between the valve seal and the
20 valve seat where some eccentricity due to manufacture tolerances between the seat 51 and the packing 53 causing their spontaneous alignment and giving rise to a better, more effective closing pressure at equal force exerted by the mobile

fitting compared to other embodiments.

Reference is now made to Figures 8 - 10 where the configurations of collar 60 and of valve packing 63 substantially correspond to the one according to Figure 7. However, shell 1 of the stopper incorporates a tothing 66 interposed
5 between valve seat 61 of collar 60 and outlet opening 3 of shell 1. This tothing 66 constitutes a breakwater, which – when the water flow is choked and when it then produces a noise – slows down and regulates the flow itself. This results in a major reduction of the noise produced by the flow.

Tothing 66 can be a part of shell 1 of the stopper in which it can be made
10 in a simple and economical fashion, for example, by means of broaching. Alternatively, it can also be made up of correspondingly upwardly extending configured appendix of collar 60. In another alternative, the tothing 66 could also be made up of a separate member inserted in the desired position.

Tothing 66 cooperates in an optimum fashion with a frusto-conical flared
15 valve seat 61; however, it can also be adopted in the presence of valve seats having different shapes.

The stem valve stopper according to the invention thus can attain all or a part of the above stated advantages without any significant increase in its production cost. In particular, the designer can in an optimum fashion adapt the
20 features of the stopper to any special requirements connected with each particular application.

It is understood that the invention is not confined to the embodiments

described and illustrated by way of example. Changes are well within the grasp of one ordinary skilled in the field, especially as regards to the configuration of the collar, the valve seat, the valve packing or the static packing and, when it exists, the internal space intended to cause the radial dilation of the valve

5 packing. Furthermore, the invention could also be applied to rising valve stem stoppers of a kind where the mobile fitting is screw-connected to the shell of the stopper and is directly linked to the operating stem so that both of the mentioned parts will be shifted axially when the operating stem is rotated. In this case, the valve seal can be carried by the mobile fitting in a rotatable manner.

10 Other variations are foreseen without departing from the spirit and scope of the invention as defined in the appended claims.

I claim:

1. A valve stopper includes a shell constructed to be sealingly securable to the body of one of a cock, tap and faucet; a mobile fitting, mounted
5 in an axially movable fashion inside said shell of the stopper and bearing a valve seal, and an operating stem mounted rotatably in said shell of the stopper having one end inside the shell operably connected with said mobile fitting, and an outer end protruding from the shell of the stopper and constructed to mount an operating handle, said valve stopper characterized by;
10 a collar made of rigid material being mounted in the shell of the stopper at its end opposite the end where said operating stem protrudes;
said collar, at one axial end forms a valve seat cooperating with said valve seal and, on the opposite side, carries a static sealing element constructed to provide a sealing hold about a mouth of an inlet passage in the body of one of the
15 cock, tap and faucet.
2. A stem valve stopper as defined in claim 1, further characterized by;
said valve seal being made of elastomeric material, and having a hollow space facing upstream so that when in the closing mode, it is dilated by the water
20 pressure against said valve seat.
3. A stem valve stopper as defined in Claim 1 further characterized by:

said operative stem mounted only for rotatable motion but fixed in an axial direction in said shell;

said mobile fitting is non-rotatably fixed on said shell and threadably engaged to said stem for axial movement as said stem is rotated.

5

4. A stem valve stopper as defined in claim 3 further characterized by; in that said valve seat being made of elastomeric material, is made up of one of an O-ring and an annular washer.

10

5. A stem valve as defined in Claim 3 further characterized by: said static seal is made up of a seal of the commercial type from one of an O-ring and an annular seal with a rectangular cross-section.

15

6. A stem valve stopper as defined in claim 3 further characterized by: said valve seat has a substantially outwardly flared configuration, constructed to direct the flow radially outward toward the periphery of the stopper where the outlet passages are located.

20

7. A stem valve stopper as defined in Claim 3 further characterized by: said valve seal has a substantially bell-shaped configuration and

cooperates with a substantially cylindrical valve seat with a flared mouth.

8. A stem valve stopper as defined in Claim 3 further characterized
by:

5 a toothed surface capable of slowing down and regulating the flow under
conditions of severe choking being positioned in a region immediately following
said valve seat in the direction of flow.

9. A stem valve stopper as defined in claim 8 further characterized
10 by:

said toothed surface being integrally formed with the shell of the stopper
valve.

10. A stem valve stopper as defined in claim 8 further characterized
15 by:

said toothed surface being integrally formed as part of the collar
presenting the valve seat.

11. A stem valve stopper as defined in claim 8 further characterized
20 by:

said toothed surface being part of a separate member inserted in the shell
of the stopper between said collar and an outlet in said shell.

12. A stem valve stopper as defined in claim 1 further characterized
by:

said valve seal being made of elastomeric material and being made up of
5 one of an O-ring and an annular washer.

13. A stem valve stopper as defined in claim 1 further characterized
by:

said static seal being made up of a seal of the commercial type from one
10 of an O-ring and an annular seal with a rectangular cross-section.

14. A stem valve stopper as defined in claim 1 further characterized
by:

said valve seat having a substantially outwardly flared configuration
15 constructed to direct the flow radially outward toward the periphery of the
stopper where the outlet passages are located.

15. A stem valve stopper as defined in claim 1 further characterized
by:

20 said valve seal having a substantially bell-shaped configuration and
cooperates with a substantially cylindrical valve seat with flared mouth.

16. A stem valve stopper as defined in claim 1 further characterized
by:

a toothed surface capable of slowing down and regulating the flow under
conditions of severe choking being positioned in a region immediately following
5 said valve seat in the direction of flow.

17. A stem valve stopper as defined in claim 16 further characterized
by:

said toothed surface being integrally formed with the shell of the stopper.
10

18. A stem valve stopper as defined in claim 16 further characterized
by:

said toothed surface being integrally formed as a part of the collar
presenting the valve seat.
15

19. A stem valve stopper as defined in Claim 16 further characterized
by:

said toothed surface being part of a separate member inserted in the shell
of the stopper between said collar and an outlet in said shell.
20

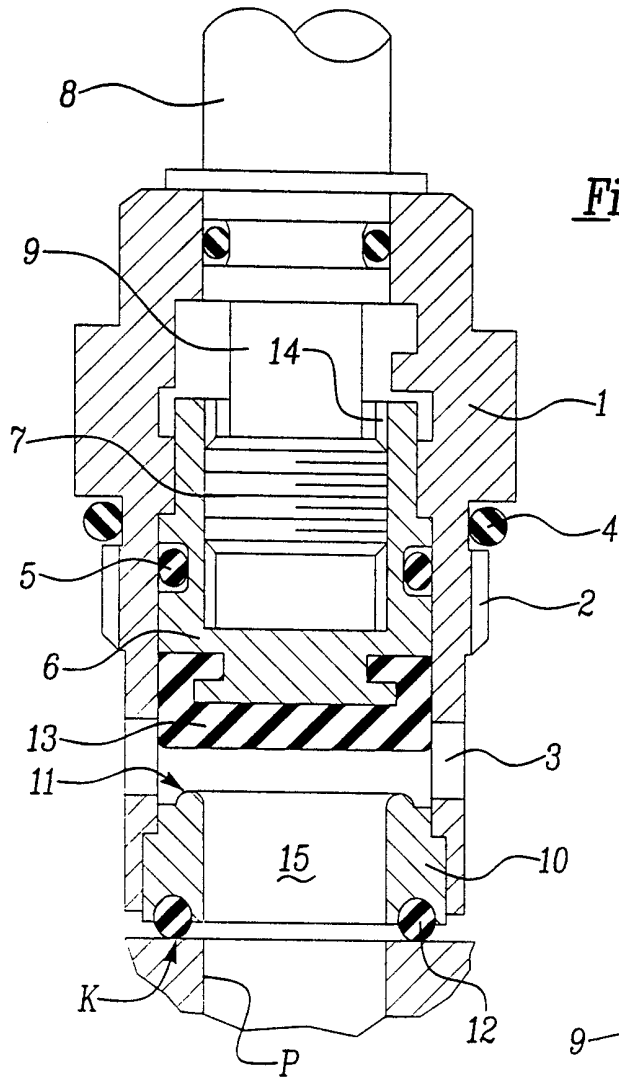

Fig-1

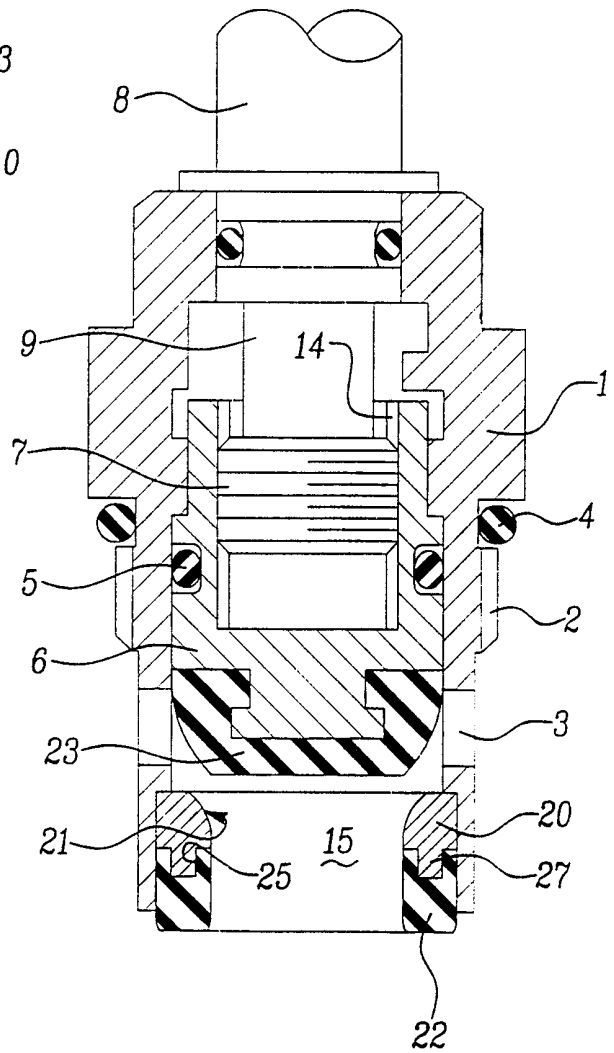

Fig-2

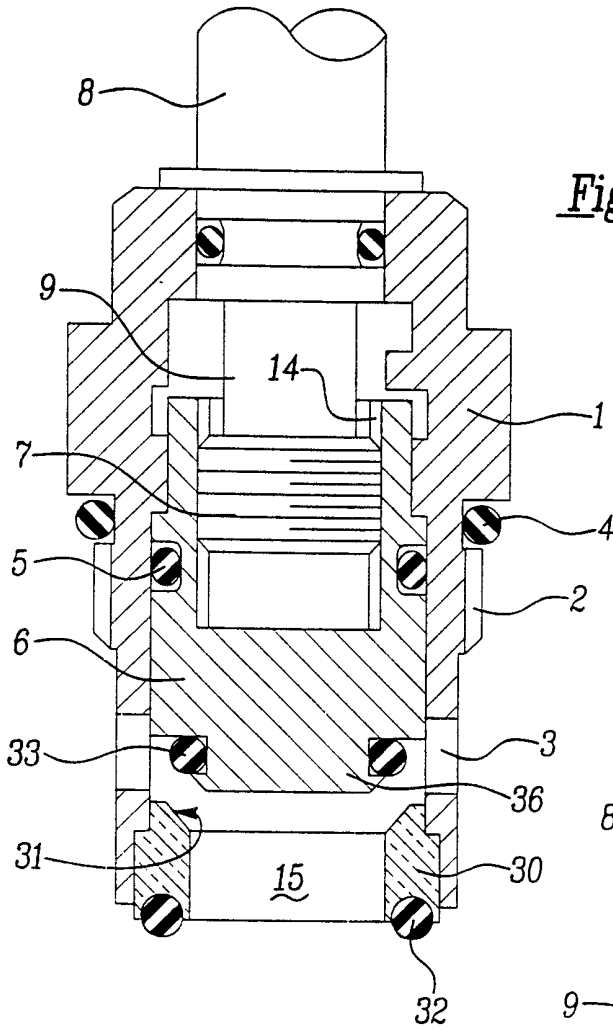

Fig-3

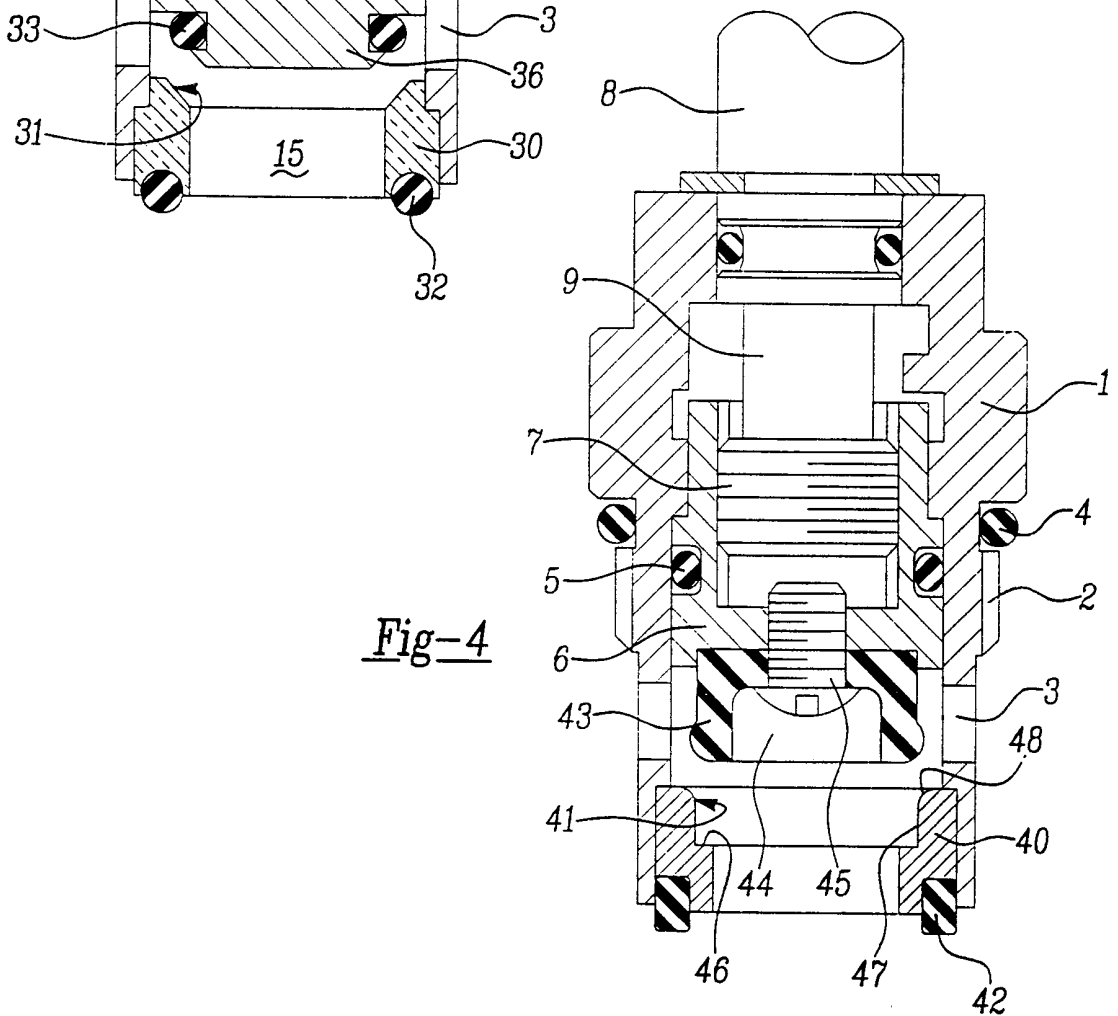

Fig-4

3/4

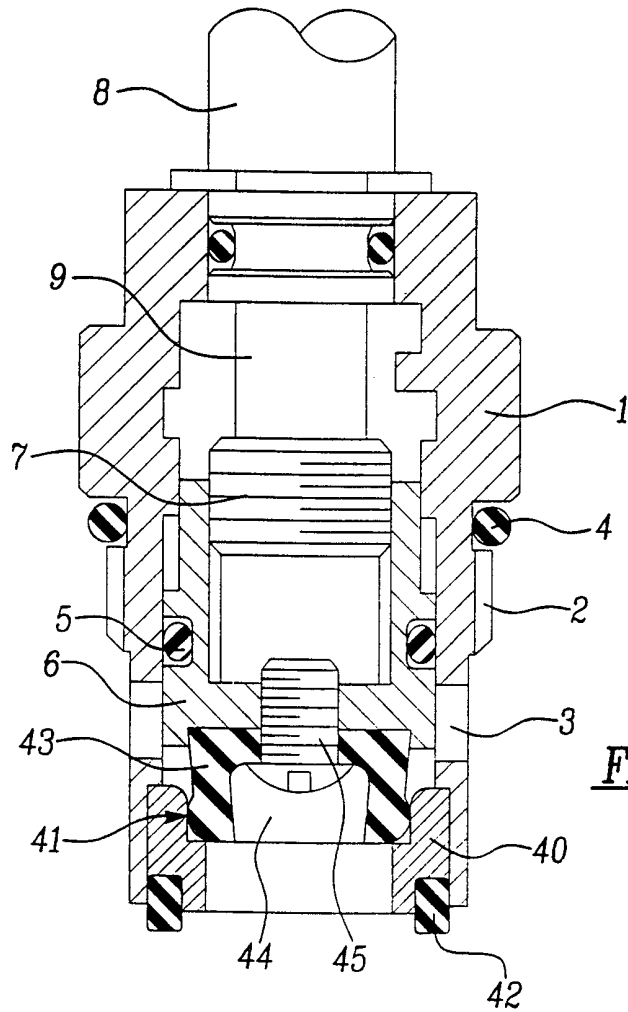

Fig-5

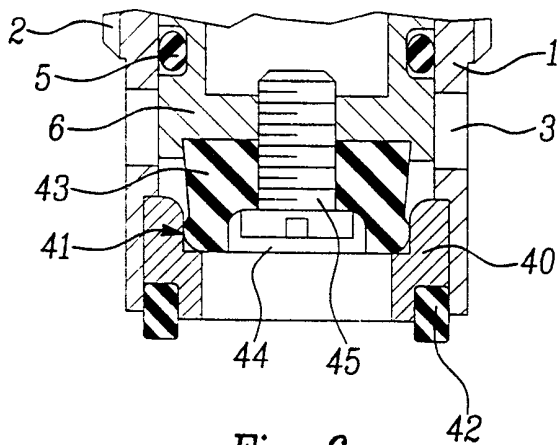

Fig-6

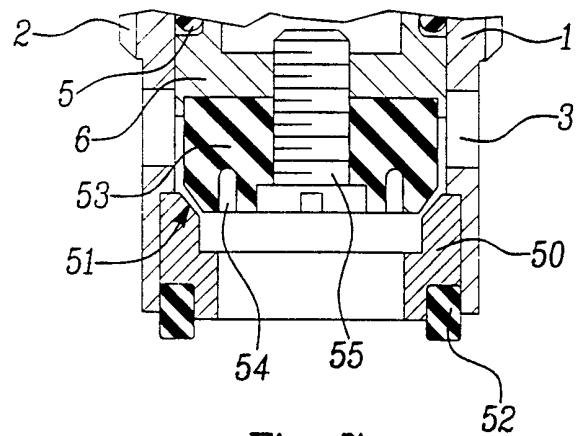

Fig-7

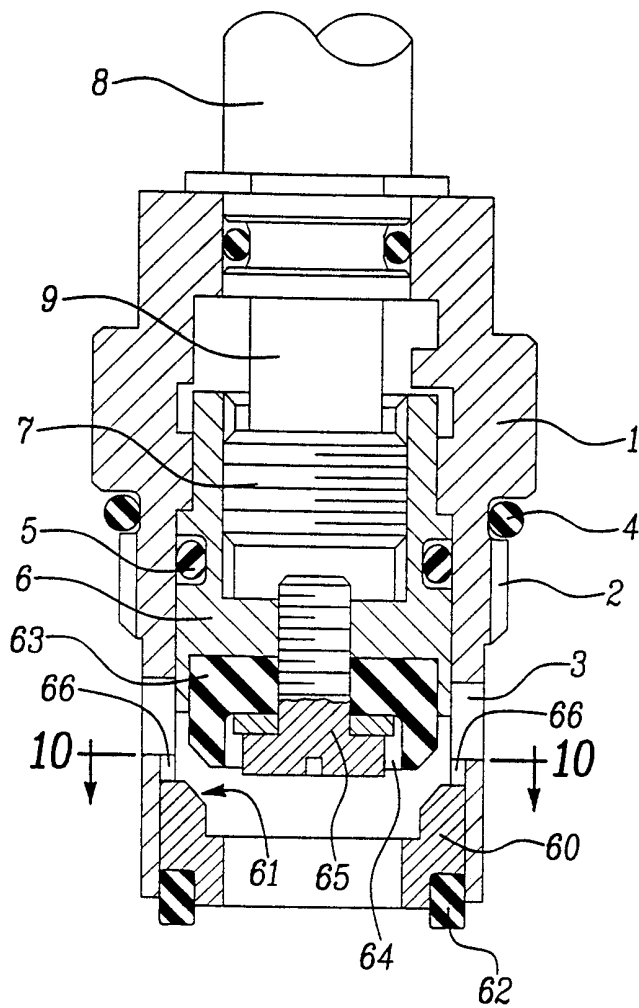

Fig-8

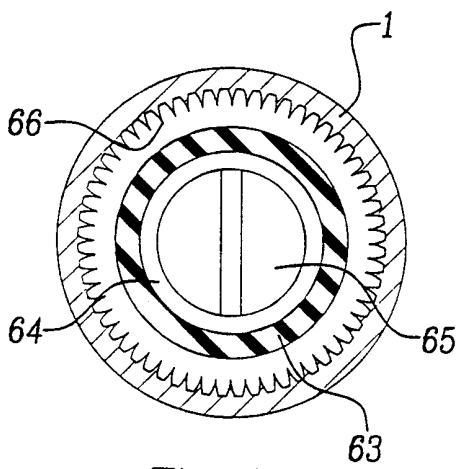

Fig-9

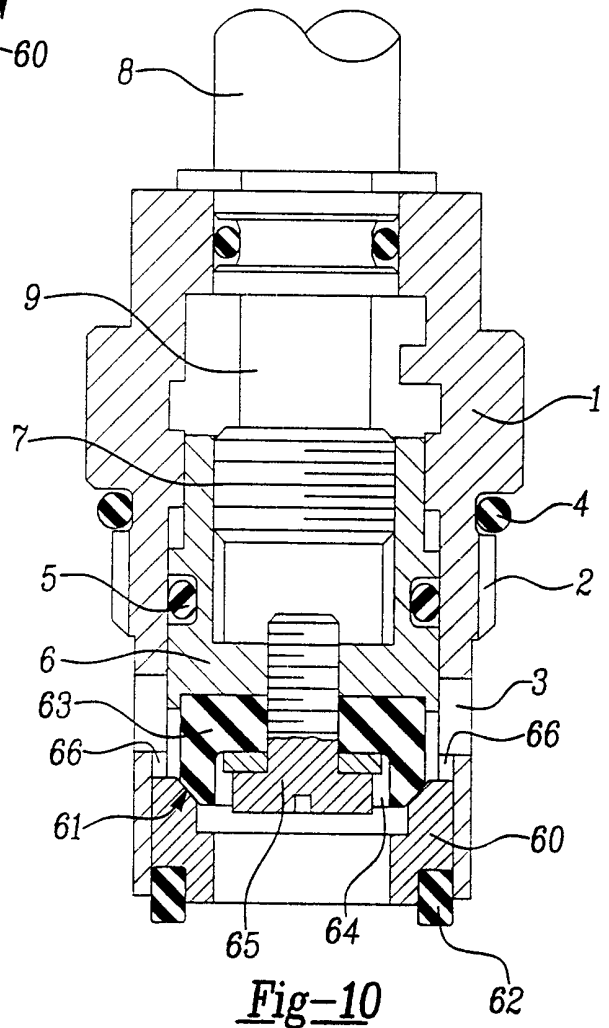

Fig-10

INTERNATIONAL SEARCH REPORT

International application No.
PCT/US98/15203

A. CLASSIFICATION OF SUBJECT MATTER
 IPC(6) :F16K 5/00, 47/02, 47/08
 US CL :137/454.5, 454.6; 251/214, 215, 118, 120, 121, 126, 127, 357
 According to International Patent Classification (IPC) or to both national classification and IPC

B. FIELDS SEARCHED
 Minimum documentation searched (classification system followed by classification symbols)
 U.S. : 137/454.5, 454.6; 251/214, 215, 118, 120, 121, 126, 127, 357

Documentation searched other than minimum documentation to the extent that such documents are included in the fields searched

Electronic data base consulted during the international search (name of data base and, where practicable, search terms used)

C. DOCUMENTS CONSIDERED TO BE RELEVANT

Category*	Citation of document, with indication, where appropriate, of the relevant passages	Relevant to claim No.
X	US 3,006,361 A (REINEMANN) 31 October 1961, see entire patent.	1-7, 12-15
---		-----
Y	US 2,649,273 A (HONEGGER) 18 August 1953, see entire patent.	8-11, 16-19

Further documents are listed in the continuation of Box C. See patent family annex.

* Special categories of cited documents:	*T* later document published after the international filing date or priority date and not in conflict with the application but cited to understand the principle or theory underlying the invention
A document defining the general state of the art which is not considered to be of particular relevance	*X* document of particular relevance; the claimed invention cannot be considered novel or cannot be considered to involve an inventive step when the document is taken alone
E earlier document published on or after the international filing date	*Y* document of particular relevance; the claimed invention cannot be considered to involve an inventive step when the document is combined with one or more other such documents, such combination being obvious to a person skilled in the art
L document which may throw doubts on priority claim(s) or which is cited to establish the publication date of another citation or other special reason (as specified)	*G* document member of the same patent family
O document referring to an oral disclosure, use, exhibition or other means	
P document published prior to the international filing date but later than the priority date claimed	

Date of the actual completion of the international search 01 OCTOBER 1998	Date of mailing of the international search report 30 OCT 1998
--	--

Name and mailing address of the ISA/US Commissioner of Patents and Trademarks Box PCT Washington, D.C. 20231 Facsimile No. (703) 305-3230	Authorized officer <i>George L. Walton</i> GEORGE L. WALTON Telephone No. (703) 308-2596
---	---