

J. W. S. & W. P. JONES.
 COUCH OR BED.
 APPLICATION FILED JUNE 18, 1909.

966,450.

Patented Aug. 9, 1910.

2 SHEETS—SHEET 1.

Fig. 1.

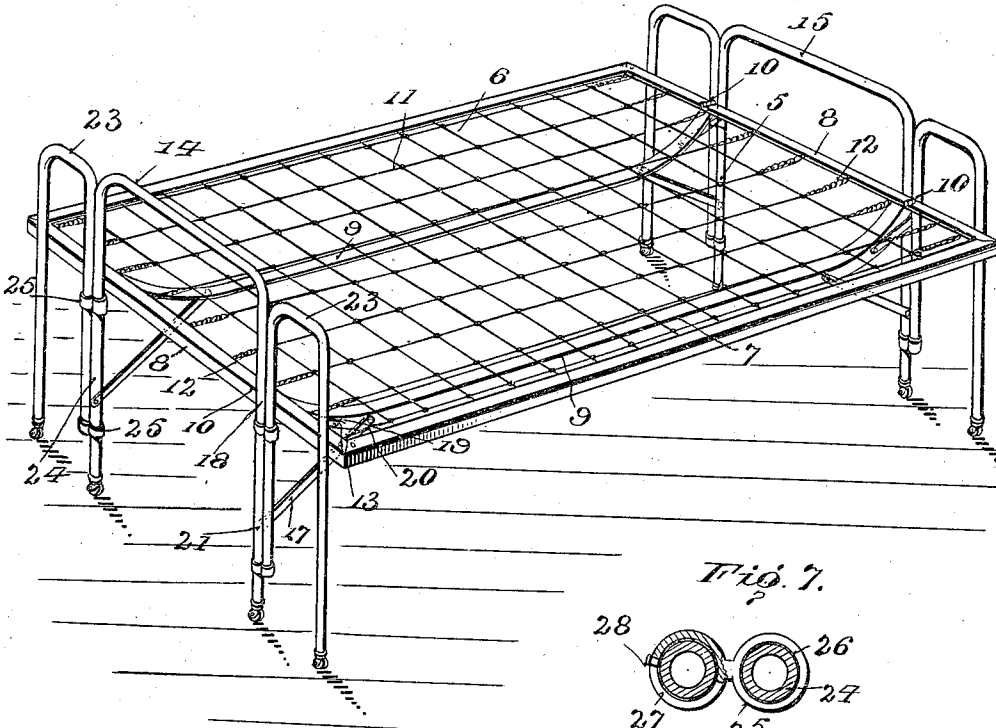

Fig. 7.

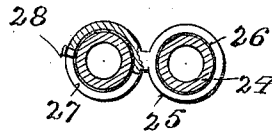
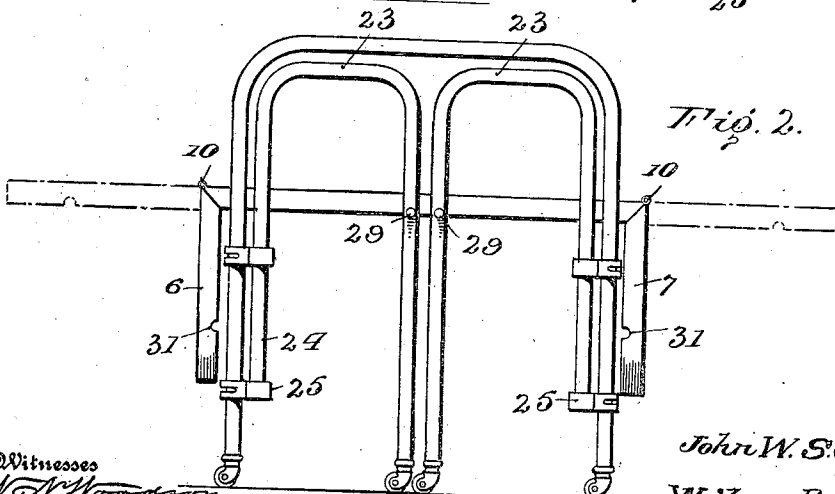

Fig. 2.



Witnesses

W. J. Woodman

Jessie M. Fallin

Inventor

John W. S. Jones

Wilson P. Jones

By

W. H. Macey, Attorneys

J. W. S. & W. P. JONES.
 COUCH OR BED.
 APPLICATION FILED JUNE 18, 1909.

966,450.

Patented Aug. 9, 1910.

2 SHEETS—SHEET 2.

Fig. 3.

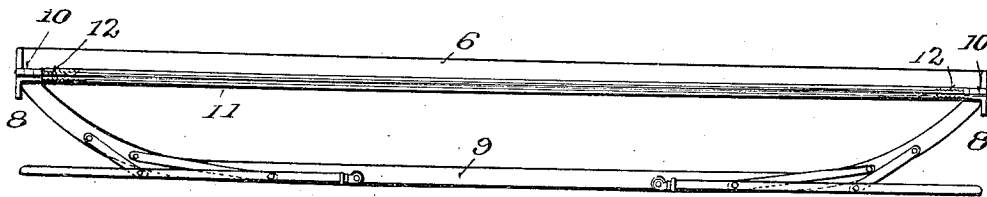

Fig. 4.

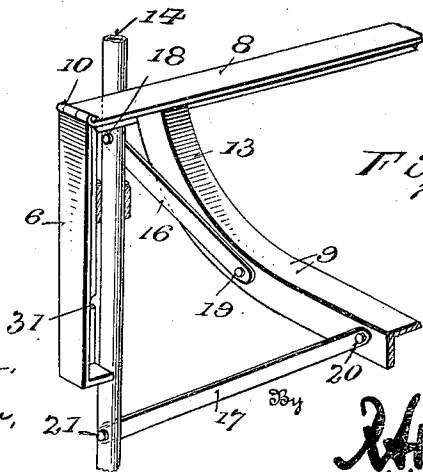
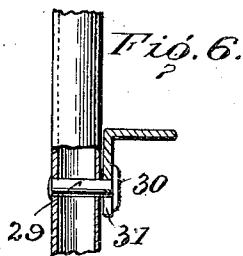
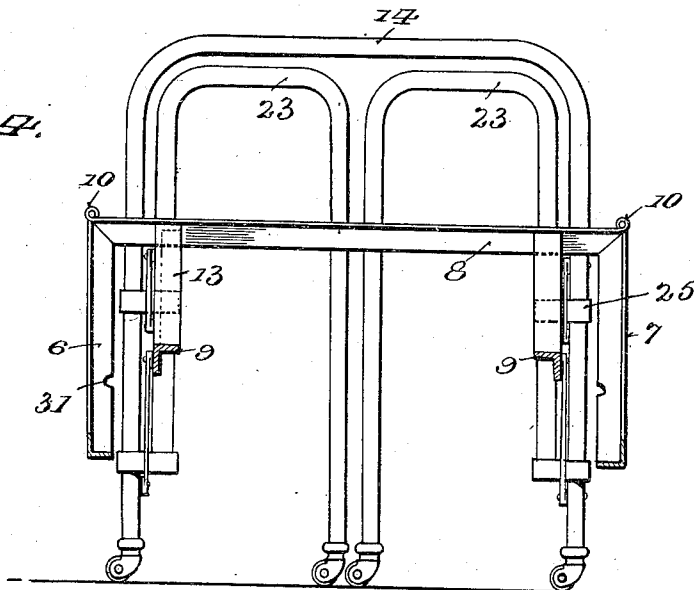

Fig. 5.

Witnesses
W. V. Woodson,
Juana M. Gallin,

Inventor
John W. S. Jones
Wilson P. Jones

H. A. Macy, Attorneys.

UNITED STATES PATENT OFFICE.

JOHN W. S. JONES AND WILSON P. JONES, OF BIRMINGHAM, ALABAMA.

COUCH OR BED.

966,450.

Specification of Letters Patent.

Patented Aug. 9, 1910.

Application filed June 18, 1909. Serial No. 503,001.

To all whom it may concern:

Be it known that we, JOHN W. S. JONES and WILSON P. JONES, citizens of the United States, both residing at Birmingham, in the county of Jefferson and State of Alabama, have invented certain new and useful Improvements in Couches or Beds, of which the following is a specification.

This invention relates to folding beds or couches and has for its object to provide a comparatively simple and thoroughly efficient device of this character the construction of which is such as to permit the same to be compactly folded for transportation or storage.

A further object is to provide a folding bed or couch having curved side rails connected through the medium of pivoted links with the head and foot sections of the bed thus to provide a clearance between the springs and the side rails and also to permit the head and foot sections to be moved to folded position parallel with the side rails.

A further object is to form the head and foot sections of the bed or couch with pivotally mounted auxiliary sections or feet adapted to engage and support the side sections when the latter are swung upwardly to elevated position.

A still further object of the invention is generally to improve this class of devices, so as to increase their utility, durability, and efficiency, as well as to reduce the cost of construction.

Further objects and advantages will appear as the description proceeds, it being understood that various changes in form, proportions, and minor details of construction may be resorted to within the scope of the appended claims.

For a full understanding of the invention and also to acquire a knowledge of the details of construction and the means for effecting the result, reference is to be had to the following description, and accompanying drawings, in which;

Figure 1 is a perspective view of the combined couch or bed constructed in accordance with our invention; the pivoted side sections being shown in horizontal alinement with the intermediate section to produce a bed; Fig. 2 is an end elevation, the pivoted side sections being shown in dotted lines in elevated position, Fig. 3 is a side elevation showing the bed or couch in folded position; Fig. 4 is a transverse sectional view; Fig. 5

is a perspective view of a portion of the bed showing the construction of the curved side rail and the links for connecting the side rail with the adjacent head sections; Fig. 6 is a detailed sectional view showing the manner of locking the pivoted side sections in engagement with the auxiliary head and foot sections; Fig. 7 is a detail view of one of the castings for the auxiliary head and foot sections of the bed.

Corresponding and like parts are referred to in the following description and indicated in all the views of the accompanying drawings by the same reference characters.

The folding bed or couch forming the subject matter of the present invention includes a relatively stationary intermediate section or body portion 5, having side sections 6 and 7 pivotally connected therewith, and movable laterally and downwardly against the intermediate section when the device is used as a couch, and adapted to be swung upwardly into horizontal alinement with the intermediate section when the couch is used as a bed. The intermediate section 5 comprises spaced transverse rails 8, preferably in the form of angle bars, as shown, and connected by longitudinal side rails, the opposite ends of the side sections 6 and 7 being pivotally connected to the end rails 8, as indicated at 10.

The bottom 11 covers both the intermediate section and the side sections of the couch and is preferably formed of pivotally united links, the terminal links of which are connected to the end rails 8 and the corresponding end rails of the side sections by means of coiled springs 12. The opposite ends of the side rails 9 are bent or curved upwardly at 13 thereby to provide a clearance between the side rails and the springs and also to permit the head and foot sections 14 and 15 to be moved to folded position parallel with the side rails, as best shown in Fig. 3 of the drawings. The opposite legs of the head section 14 are pivotally connected with the intermediate section 5 of the bed by means of links 16 and 17, one of the links on each side of the bed being shorter than the other, and having one end thereof pivotally mounted at 18 on the adjacent leg of said head section and its other end pivotally mounted at 19 on the curved terminal of the adjacent side rail. The pivoted end 20 of each long link on each side of the bed is disposed in

advance of the pivot pin 19 of the adjacent short link 16, while the pivot pin 21 of said long link pierces the adjacent leg of the head section at a point above the caster. Similar
 5 links form a pivotal connection between the opposite legs of the foot section 15 and the curved terminals of the side rails as shown. Thus it will be seen that when the bed is in the position shown in Fig. 1 of the drawing
 10 the braces 16 and 17 at each end thereon will support the adjacent head and foot sections in vertical position and prevent accidental collapsing of the bed when the latter is occupied.

15 Pivotaly connected with the head and foot sections 14 and 15 are auxiliary head and foot sections 23 which latter are preferably of inverted U-shape and adapted to support the side sections 6 and 7 when said
 20 side sections are moved to elevated position in alinement with the intermediate bed section.

Rigidly secured to the short leg 24 of each auxiliary section 23 are spaced brackets or
 25 castings 25 having vertically alined sockets 26 formed therein for the reception of the legs of the adjacent main head or foot section, thus to permit the auxiliary sections 23 to be swung laterally in alinement with the
 30 sections 14 and 15 when the couch is converted into a bed and to be swung laterally and inwardly against the sections 14 and 15 when the device is changed from a bed to a couch. The brackets or castings 25 are
 35 rigidly secured to the sections 23 but are free to swing laterally on the head and foot sections 14 and 15, there being segmental slots 27 formed in the castings at the sockets 26 and adapted to receive suitable
 40 pins 28 secured to the head and foot sections for the purpose of limiting the swinging movement of the auxiliary sections 23. The outer or long leg of each section 23 is
 45 provided with a laterally extending pin 29 having an enlarged head 30, the shanks of the pins 29 being adapted to enter suitable recesses 31 formed in the pivoted side sections 6 and 7 when the latter are in elevated position, thus to brace the side
 50 sections 6 and 7 and prevent accidental folding of the same when the bed is occupied.

In order to fold the bed or couch for transportation or shipment the side sections
 55 6 and 7 are disengaged from the pins 29 and swung laterally and downwardly on the intermediate bed section 5 after which the auxiliary sections 23 are swung laterally and inwardly against the adjacent head and foot
 60 sections 14 and 15 and the latter folded beneath the intermediate section 5, thereby causing the head and foot sections together with the auxiliary sections 23 to rest on the floor or other support in a position parallel
 65 with the side rails 9 as best shown in Fig. 3 of the drawings, so that the bed will take

up very little space and thus permit several of such beds to be arranged one above the other in superposed relation during transportation or shipment.

When it is desired to convert the couch
 70 into a bed the side sections 23 are swung laterally to the position shown in Fig. 1 of the drawings, and the side sections 6 and 7 swung downwardly until the recesses 31 engage the pins 29 and in which position the
 75 side sections 6 and 7 will be securely retained in horizontal alinement with the intermediate bed section 5.

It is obvious that by disengaging the side rails 6 and 7 from the pins 29 and swinging
 80 the auxiliary section 23 laterally to the position shown in Fig. 2 of the drawings, the device may be used as an ordinary couch.

By curving the opposite ends of the side rails upwardly, a clearance between the side
 85 rails of the springs 11 is provided when the bed or couch is in both folded and operative positions, this construction of side rail also obviating the necessity of building up the usual straight side rails to provide a clear-
 90 ance, as is at present the case in this class of devices.

It will here be noted that the bed or couch may be folded without the necessity
 95 of first removing screws, bolts, or similar fastening devices, and may be readily set up for use by merely swinging the head and foot sections outwardly to the position shown in Fig. 1 of the drawings.

The cost of constructing a bed provided
 100 with curved side rails is not only materially less than the cost of making a bed provided with straight side rails, but by reason of the curved or deflected ends of the rails the bed is reinforced and strengthened and a proper
 105 clearance provided between the upper rails and the springs.

While the curved side rails and pivoted
 110 head and foot sections are shown in connection with a couch, it will of course be understood that the same may be used with equally good results on cots, davenport or wherever a device of this construction is found desirable or applicable.

Having thus described the invention, what
 115 is claimed as new is;—

1. A folding couch including a body portion, having spaced side rails, the opposite
 120 ends of which are curved upwardly, head and foot sections supporting the body portion, side sections pivotally connected with said body portion, links forming a pivotal connection between the head and foot sections and the curved terminals of the side
 125 rails, auxiliary sections pivotally mounted on the head and foot sections and provided with means for supporting the side sections in horizontal position, said head and foot sections together with the auxiliary sections being foldable laterally to a position be- 130

neath the body portion and parallel with the side rails thereof.

2. A folding couch including a body portion, side sections pivotally connected with the body portion, head and foot sections supporting said body portion and free to swing beneath the same, links forming a pivotal connection between the head and foot sections and the body portion, and auxiliary sections pivotally connected with the head and foot sections and adapted to engage the pivoted side sections for supporting the latter in horizontal alinement with the body portion, said auxiliary sections being movable to a position within the lines of the head and foot sections and adapted to be folded together with said head and foot sections beneath the body portion.

3. A folding couch including a relatively stationary intermediate section, head and foot sections supporting the intermediate section, links forming a pivotal connection between the head and foot sections and said intermediate section, side sections pivotally connected with the intermediate section and having recesses formed therein, and auxiliary sections pivotally connected with the head and foot sections and provided with pins adapted to enter the recesses in the side sections for supporting the latter in horizontal alinement with the intermediate section, said auxiliary sections being foldable simultaneously with the head and foot sections to a position beneath the body portion.

4. A folding couch including a relatively stationary intermediate section, side sections pivotally connected therewith, and having recesses formed in their opposite ends, head and foot sections supporting the intermediate section, links forming a pivotal connection between the head and foot sections and said intermediate section, auxiliary sections pivotally mounted on the head and foot sections, and movable laterally to extended position, and pins carried by the auxiliary sections and adapted to enter the recesses in the side sections for supporting the latter in a horizontal plane, said auxiliary sections being movable to a position within the lines of the head and foot sections.

5. A folding couch including a body portion having end rails spaced apart by side rails having their opposite ends curved upwardly and rigidly connected to the adjacent end rails, side sections pivotally connected with the body portion, head and foot sections forming a support for the body portion, oppositely inclined links of different lengths forming pivotal connections between the curved ends of the side rails and the adjacent head and foot sections of the bed, and auxiliary sections pivotally connected with the head and foot sections, said auxiliary sections being movable to a position within the lines of the head and foot sections and foldable together with the latter beneath said body portion.

6. A folding couch including a body portion having movable side sections, head and foot sections supporting the body portion, auxiliary sections for supporting the side sections in horizontal alinement with the body portion, brackets loosely mounted on the head and foot sections and rigidly secured to the auxiliary sections, said auxiliary sections being foldable to a position within the lines of the head and foot sections.

7. A folding couch including a body portion having movable side sections, head and foot sections supporting the body portion and provided with laterally extending stop pins, auxiliary sections having means for engagement with the side sections for supporting said sections in horizontal alinement with the body portion, and brackets rigidly secured to the auxiliary sections and provided with sockets loosely fitting the head and foot sections and provided with segmental slots adapted to receive the stop pins, said auxiliary sections being movable to a position within the lines of the head and foot sections.

In testimony whereof we affix our signatures in presence of two witnesses.

JOHN W. S. JONES. [L. S.]
WILSON P. JONES. [L. S.]

Witnesses:

R. F. MANLY,
FANNY HENRY.