

E. W. BRIDGE.

Improvement in Toy Watches.

No. 133,196.

Patented Nov. 19, 1872.

Fig. 1

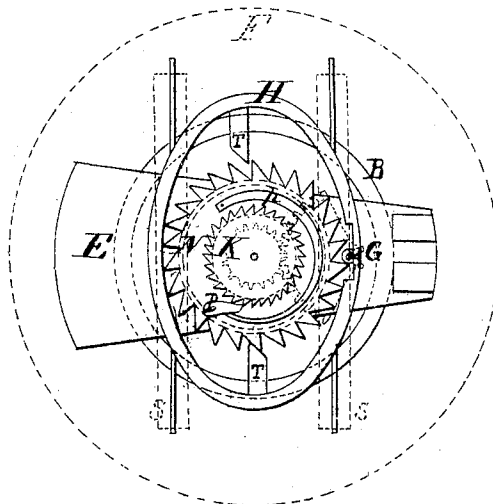
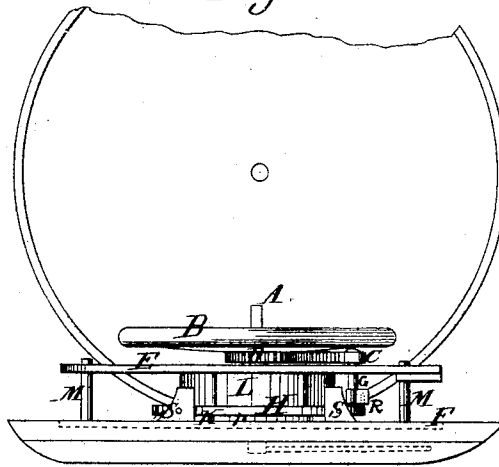

Fig. 2



Witnesses.

S. M. Hopkins
John H. Carter

E. W. Bridge
Inventor.

By
Chas. L. Burrows
att'y.

UNITED STATES PATENT OFFICE.

EDWARD W. BRIDGE, OF PHILADELPHIA, PENNSYLVANIA.

IMPROVEMENT IN TOY WATCHES.

Specification forming part of Letters Patent No. **133,196**, dated November 19, 1872.

To all whom it may concern:

Be it known that I, EDWARD WHITECROFT BRIDGE, of the city and county of Philadelphia, State of Pennsylvania, have invented an Automatic Toy Watch; and I do hereby declare the following to be a full, clear, and exact description of the same, reference being had to the accompanying drawing making part thereof.

The object of the invention is to produce a toy watch which shall take the place of those now made and sold for the amusement and gratification of children. Those watches, ordinarily, have hands painted or printed upon the dial-face, and in some instances have hands, which are made to move by a key applied to a short post, on which they are fixed, and which, of course, cease to move when the key is withdrawn. By my invention I am enabled to produce a cheap and inexpensive watch, which can be made and sold at little cost, shall be within the means of every one, and which, on being "wound" with a key, will run for a few minutes when the key is withdrawn, but which is not designed, of course, to keep time, being strictly a toy.

To enable others skilled in the art to make and use my invention, I will describe its construction and operation.

In the accompanying drawing, in which the same letters designate the same parts in both figures, Figure 1 is a plan view of the works, looking from the face of the watch; and Fig. 2 is a side view, the back of the watch being represented as open.

A represents the center shaft or key-post, to which are applied the balance-wheel B, balance-pinion D, shown dotted in Fig. 1, ratchet-wheel K, and escape-wheel N. The back end of this post is made square to receive the key with which the mechanism is to be wound, and to its front end, under the crystal, are secured a pair of hands, shown dotted in the lower part of Fig. 2. M M are posts, to which are secured the dial-plate F and back plate E. G is a shaft, to which are secured a toothed sector, C, and a tappet, R, the latter engaging a pin projecting rearward from an ellip-

tical pallet, H, which is arranged to slide back and forth, parallel to the escape-wheel, on the pallet-rest S S, and being provided with teeth T T, which engage alternately with the teeth of the escape-wheel N. L is a barrel, containing a coiled spring, which constitutes the whole motive power of the works; and P is a click, which is held to engagement with the ratchet K by a spring, *p*. One end of the coiled mainspring is attached to a stationary post and the other to the center shaft or key-post A. These are all inclosed in a cheap metallic case, and the dial-face to be of paper with the figures representing hours printed upon it.

The operation is as follows: The key being inserted through a hole in the back of the case and turned to the right, the mainspring is coiled up and held by the ratchet K and click P. When fully wound the key is withdrawn. As the spring uncoils the escape-wheel N turns and its teeth, engaging alternately with those on the pallet H, causes the latter to slide horizontally back and forth on its rests S S. As the pallet slides, the pin upon it engages alternately with the two teeth of the pallet R, causing it, its shaft G, and sector C to vibrate, and the latter, gearing with the balance-pinion D, compels it and the balance-wheel B to move back and forth in a circular path. The rotary motion of the shaft A and escape-wheel N compels the hands to traverse around the dial-face, and the sound produced by the movements of the several parts is very similar to the beat of an ordinary watch.

The works and the case are to be made of very cheap material; and, the mechanism being very simple and void of complication, it will be seen that I produce an article which will be made and sold at a very low cost, and afford much more amusement to children than the old style of toy watches, and at but little or no additional expense.

Having thus described my invention, what I claim is—

1. An automaton toy watch, substantially as herein described.

2. The combination of the elliptic pallet H, tappet R, shaft G, sector C, pinion D, and balance-wheel B, for governing the time and speed of movement of the hands and their actuating mechanism, substantially as and for the purpose described.

3. The combination, with the case and dial made substantially as herein described,

of mechanism, substantially as described, for producing a sound and movement similar to those of a watch.

EDWARD WHITECROFT BRIDGE.

Witnesses:

WILLIAM K. FERGUSON,
GEORGE W. SYMONDS.