



Europäisches Patentamt
European Patent Office
Office européen des brevets



(11) **EP 0 836 363 B1**

(12) **EUROPEAN PATENT SPECIFICATION**

(45) Date of publication and mention
of the grant of the patent:
03.09.2003 Bulletin 2003/36

(51) Int Cl.7: **H04R 25/00**

(21) Application number: **96115687.4**

(22) Date of filing: **01.10.1996**

(54) **Loudness limiter**

Lautstärkebegrenzung

Limiteur d'intensité sonore

(84) Designated Contracting States:
AT CH DE DK FR LI

(74) Representative: **Troesch Scheidegger Werner AG**
Patentanwälte
Postfach
8032 Zürich (CH)

(43) Date of publication of application:
15.04.1998 Bulletin 1998/16

(56) References cited:
EP-A- 0 237 203
WO-A-94/23548

EP-A- 0 661 905
US-A- 4 475 230

(73) Proprietor: **PHONAK AG**
8712 Stäfa (CH)

(72) Inventor: **Bächler, Herbert, Dr.sc.techn.,**
Dipl.-EL-Ing.
8706 Meilen (CH)

EP 0 836 363 B1

Note: Within nine months from the publication of the mention of the grant of the European patent, any person may give notice to the European Patent Office of opposition to the European patent granted. Notice of opposition shall be filed in a written reasoned statement. It shall not be deemed to have been filed until the opposition fee has been paid. (Art. 99(1) European Patent Convention).

Description

[0001] The present invention is directed to a method for limiting the signal transmitted to the human ear in dependence on an incoming acoustical signal and is further directed to a hearing apparatus which comprises an input acoustical/ electric transducer, the output thereof being operationally connected to the input of a signal processor unit with a controllable spectral transfer characteristic, the output of this processor unit being operationally connected to the input of an output transducer for the human ear.

Definition of Loudness

[0002] Loudness of an audio signal is a psycho-acoustical entity. Several models have been developed to quantify the loudness which a standard individual will perceive dependent on incoming audio signals. We refer as examples to:

- E. Zwicker, "Psychoakustik", Springer Verlag Berlin, Hochschultext, 1982;
- A. Leijon "Hearing Aid Gain for Loudness-Density Normalization in Cochlear Hearing Losses with Impaired Frequency Resolution", Ear and Hearing, Vol. 12, No. 4, 1990;
- EP-0 661 905 of the same applicant as the present application;
- H. Dillon, "Compression? Yes, but for low or high frequencies, for low or high intensities, and with what response times?", Ear and Hearing, Vol. 17, No. 4, 1996.

[0003] All models used for calculation of loudness perception apply the concept of an auditory filterbank and subdivide an audio signal into spectral bands. In psychoacoustic these filter-bands are called the critical bands. They provide a constant filter bandwidth on a psychoacoustical frequency scale, normalised to Bark (Zwicker) or ERB. (B. Moore "Perceptual consequences of cochlear damage", Oxford Psychology Series 28, Oxford University Press, 1995).

[0004] In a first step the auditory filterbank is performing a transformation of the physical spectrum into a so-called excitation pattern. The excitation pattern, output response of the auditory filterbank, can be calculated for arbitrary signal spectra, procedures are described in the literature (Moore).

[0005] In the second step the loudness provided by the respective cochlear excitation is calculated from the contributions in each critical band, called the specific loudness and is further integrated or summed over all the bands of the auditory filterbank, yielding the total loudness of the signal spectrum.

[0006] The parameters of the loudness model are known and standardised for normal hearing listeners and can be modified for impaired subjects accordingly, methods for the measurement of loudness model parameters of individual subjects have been proposed (S. Launer, "Loudness Perception in Listeners with Sensorineural hearing Impairment", Dissertation, Dept. of Physics, University of Oldenburg, Germany, 1995.)

[0007] With respect to the standard of normal hearing we refer to ISO 226, "Acoustics - normal equal-loudness contours", International Organization for Standardization, Geneva 1987.

[0008] Loudness of an audio signal spectrum can be generically expressed by:

$$L(S(f), P) = \sum_{k=1}^n L'_k(S_k, P_k)$$

L(P): loudness

L'_k(S_k(f), P_k): specific loudness, loudness contribution of the frequency band no. k

P_k: band specific model parameters

S_k(f): the physical spectrum of the signal in band no. k out of the physical spectrum S(f).

P: the entity of P_k parameters

[0009] In this literature loudness is often referred to with the symbol N and respectively N' instead of L, L'.

[0010] Due to safety and comfort it is known that hearing aids necessitate a system for limiting the power of signals,

as especially the sound pressure for electric/acoustical output transducers, which is transmitted to the human ear in dependence on incoming acoustical signals. Even under broader aspect and thus under the aspect of human ear protection in very loud environment, the need of such limiting is evident.

[0011] In today's hearing aid technology two limiting techniques are known, namely the so-called "peak clipping (PC)" and the so-called "automatic gain control (AGC)" technique (H. Dillon).

[0012] According to the PC technique the transmitted power is clamped to a threshold value. This has obviously the disadvantage that a considerable amount of harmonic distortion occurs as soon as the transmitted signal reaches the clipping level. It is thereby customary at hearing aids of this technique to provide the limiting threshold adjustable.

[0013] According to the AGC technique the transmitted power is measured, compared to an admitted level and according to the result of this comparison the gain of the hearing aid apparatus is adjusted as by feedback control. Thereby, it has further been proposed to divide the transfer characteristics of the hearing aid into distinct spectral bands, setting for each spectral band a specific threshold value and, by AGC, to limit the transmitted power separately in each frequency band.

[0014] All these approaches depart from the attempt to limit the power level according to a power limit where hearing becomes uncomfortable or even harmful. Thereby, it is known that human beings do not perceive physical power as especially sound pressure level, but do perceive the psychoacoustic loudness and that especially discomfort is caused by too high loudness.

[0015] Following up this knowledge, it is an object of the present invention to provide a method and an apparatus as was stated above which limits such signal transmitted to the human ear according to human perception of acoustical signals.

[0016] Departing from a method as stated above, this object is realized by

- providing a limiting hearing apparatus which generates from an input acoustical signal an output signal which is transmitted to the human ear with a controllable transfer characteristic;
- storing at the apparatus a threshold value;
- generating at the apparatus a signal which is dependent on loudness of the signal transmitted to the human ear and
- reducing loudness of the transmitted signal to the ear by automatically adjusting parameters of the transfer characteristic which determine the loudness of the signal transmitted to the human ear as soon as the signal dependent on loudness of said transmitted signal reaches the threshold value.

[0017] In opposition, especially to the approach of AGC, inventively the loudness of a transmitted signal is monitored or modelled as a test entity. This is performed by applying a model calculating the perceived loudness out of a spectrum representing an acoustical signal, and it is this loudness which is compared with a comfort loudness threshold which is standard and/or individually determined by experiments so as to limit the loudness of the transmitted signal. In a preferred embodiment lowering the loudness is performed by lowering the loudness contributions in all or in a predominant part of the critical bands individually or by equal percentage.

[0018] Also, and not limiting the present invention, the inventive method is predominantly applied with hearing aid apparatus as the limiting apparatus.

[0019] In a further preferred embodiment of the inventive method, the spectral transfer characteristic of the apparatus is set or permanently adjusted in dependence on the loudness perceived by an individual carrying the hearing aid and of the reference loudness which would be perceived by a standard individual without hearing aid.

[0020] The inventive hearing apparatus construed to perform the object as mentioned above comprises a presettable storing unit and a calculating unit with an input operationally connected to the output of the processor unit which calculating unit generates an output signal which is dependent on loudness of an acoustical signal represented by the signal at the input of the output transducer. The output of the presettable storing unit and the output of the calculating unit are operationally connected to respective inputs of a comparing unit, the output of which being operationally connected to adjusting inputs at the signal processor unit, thereby automatically adjusting its transfer characteristic. Thereby, by adjusting the transfer characteristic of the signal processor unit, the resulting loudness as monitored by the calculating unit according to a preselected model is accordingly lowered down to reaching, e.g. in a negative feedback control loop or by iteration, the value as preset in the storing unit which accords to the loudness level of maximum acceptable loudness, MAL.

[0021] The invention and further embodiments will be understood by the skilled artisan when reading the detailed description and claims which follow. The figures show:

fig. 1 a highly simplified functional block/signal flow diagram of an inventive limiting apparatus performing the in-

ventive method,

fig. 2 a functional block/signal flow diagram of a hearing aid apparatus construed according to the present invention and in today's preferred form,

fig. 3 heuristically the spectrum of a signal at the output of the inventive apparatus leading to over-loudness and limited to a loudness below or on MAL.

[0022] According to fig. 1, an inventive limiting apparatus comprises an input acoustical/electrical transducer 1, the output thereof being operationally connected to the input of a processor unit 3, the output of which being operationally connected to an output transducer, as shown to an output electrical/mechanical transducer 5.

[0023] The signal processor unit 3 has a transfer characteristic $T(f)$ as a function of frequency f (in Hz, Bark or ERB) which is adjustable at control inputs E_3 as exemplified with the characteristics in unit-block 3. As will be described later in connection with the preferred embodiment, the transfer function T is preferably formed by a bank of filters e.g. in parallel structure, each filter defining and thus predominantly acting in a specific spectral band, e.g. according to the critical bands of human hearing.

[0024] A calculating unit 7 has its input operationally connected to the output of processor unit 3 and calculates loudness $L(S,P)$ of the output signal of unit 3. This unit performs calculation of loudness L following a selected loudness model, as e.g. disclosed in the EP-0 661 905 or in S. Launer, which both references are incorporated with respect to loudness modelling into the present description.

[0025] Selected model parameters P are input to the calculation unit 7. The output of the calculation unit 7 representing loudness as a psychoacoustical entity is fed to an input of a comparing unit 9, the other input of which being operationally connected to a storing unit 11 which has been loaded with the MAL-value, be it of an individual or be it as a generic standard safety value. If the loudness L -value as calculated by unit 7 reaches or exceeds the MAL-value, the comparator unit 9 acts on an adjusting unit 13 wherein transfer function control signals applied to E_3 are adjusted so as to reduce loudness $L(S,P)$ as modelled by calculation unit 7.

[0026] Thus, the actual loudness as transmitted to the human ear and thus perceived is monitored and the signal transferred to the human ear is reduced as soon as the monitored loudness reaches MAL.

[0027] In fig. 2 a preferred embodiment of the present invention implied preferably in a hearing aid apparatus is shown.

[0028] The processor unit 30 is construed as a filter bank with a number of band-pass filters, e.g. in parallel structure, and acting preferably each predominantly in one of the critical frequency bands or realized as a Fast-Fourier transform unit. Attention is drawn to the EP-0 661 905, especially to figs. 12a to 16, and the respective description with respect to such filter bank provided for loudness correction on an individual "I" to which, via output transducer 5, loudness corrected acoustical signals are transmitted.

[0029] At the output A of processor unit 30 calculating unit 70a calculates, according to a loudness model selected, the loudness $L_I(S,P_I)$ which the individual "I" will perceive and as corrected by the processor unit 30 of the hearing aid. The model parameters P_I of the individual are entered into unit 70a, for instance the parameters according to the Leijon-model, whereabouts the EP-0 661 905 or S. Launer (see above) shall be considered as integral part of the present application. We draw especially the attention to fig. 15 as well as to figs. 3 to 9 and the according description of EP-0 661 905.

[0030] Similarly, the signal input to the processor unit 30 is led to a calculating unit 70b which may be implied at the same hardware unit as unit 70a and may in fact be the same unit. There, standard (N) loudness $L_N(S,P_N)$ of the incoming signal S is calculated according to standard parameters P_N as also described in the EP-0 661 905 and in Launer which, here too, shall be considered as integral parts of the present description. The output signal of the calculating units 70 respectively representing loudness L_N and L_I are operationally connected to a control unit 72 wherein the two loudness values are compared. The control unit 72 which acts with its outputs on the control inputs E_{30} which control the loudness-relevant parameters P_{30} at the processor unit 30, i.e. at the respective filters of the filter bank incorporated therein. The perceived and calculated actual loudness L_I is compared as a single time-varying value at comparing unit 90 with the MAL-value, output from storage 110. The comparison result, i.e. the output of the comparator unit 90, acts on an encoder unit 112 which generates a number of output signals led to weighing unit 114 whereat the parameter values emitted from control unit 72 to adjust the transfer function of unit 30 are further adjusted, thereby preventing L_I to increase over MAL.

[0031] In fig. 3 the spectrum a) of a signal A output from the processor unit 30 is shown over frequency e.g. scaled in Barks. The spectrum a) leads to loudness L_{Ia} as represented by the area which is shaded under spectrum a) well above the MAL-value.

[0032] By the invention according to fig. 1 or 2, this is detected and the transfer function of unit 30 is adjusted, e.g. to result in a signal A according to characteristic b) which now and according to the hatched surface area below characteristic b) accords with a loudness L_{Ib} well below MAL.

[0033] By the present invention the signal transferred to the human ear is limited according to psychoacoustical loudness perception of the human ear and not by preselecting any physical limit values.

5 **Claims**

1. A method for limiting a signal transmitted to the human ear in dependence on an incoming acoustical signal, **characterized by** the steps of:

- 10
- providing a limiting hearing apparatus generating from an input acoustical signal (S) a signal (A) transmitted to the human ear with a controllable transfer characteristic;
 - storing at said apparatus a threshold value (MAL);

15

 - generating at said apparatus a signal dependent on loudness of said transmitted signal ($L(S,P)$; $L_I(S,P_I)$);
 - reducing loudness of said transmitted signal (A) to the ear by adjusting parameters of said transfer characteristic which determine the loudness (L ; L_I) of said signal (A) transmitted to the ear as soon as said signal dependent on loudness (L ; L_I) of said transmitted signal (A) reaches said threshold value (MAL).

20 2. The method of claim 1, **characterized by** implementing said limiting hearing apparatus into a hearing aid apparatus.

25 3. The method of claim 1 or 2, **characterized by** the steps of individually adjusting said transfer characteristic in dependence on loudness as perceived by a specific individual and of loudness as perceived by a standard.

4. The method of claim 2 or 3, further comprising the steps of:

- 30
- calculating loudness ($L_N(S,P_N)$) as perceived by a standard on an acoustical signal (S) input to said apparatus;
 - calculating loudness ($L_I(S,P_I)$) as perceived from the individual on said acoustical signal and dependent on loudness of said transmitted signal (A);

35

 - calculating a desired hearing aid transfer characteristic from said calculated loudnesses of standard and individual;
 - adjusting said transfer characteristic (T) of said hearing aid according to said desired transfer characteristic;

40

 - performing said limiting by additionally adjusting said desired transfer characteristic in dependence on said loudness of said transmitted signal (A) and said threshold value (MAL).

5. A hearing apparatus, comprising

- 45
- an input acoustical/electric transducer (1), the output thereof being operationally connected to the input of
 - a signal processor unit (3; 30) with a controllable transfer characteristic (T), the output thereof being operationally connected to an input of

50

 - an output transducer (5) for the human ear,

characterized by the facts that there is provided:

- 55
- a presettable storing unit (11; 110);
 - a calculating unit (7; 70a), the input thereof being operationally connected to the output of said processor unit (3, 30) and generating an output signal which is dependent on loudness of an acoustical signal represented by said signal at the input of said output transducer (5), whereby

- the outputs of said calculating unit (7; 70a) and of said presettable unit (11; 110) are operationally connected to respective inputs of a comparing unit (9; 90);
- the output of said comparing unit (9; 90) is operationally connected to adjusting inputs (E_3 ; E_{30}) for said characteristic of said processor unit (3; 30).

6. The apparatus of claim 5, **characterized by** said transducers (1, 5) and said processor unit (3; 30) being part of a hearing aid apparatus.

7. The apparatus of claim 6, **characterized by**

- a second calculating unit (70b), the input thereof being operationally connected to the output of said input transducer (1) and generating an output signal representing a standard loudness of an acoustical signal input to said input transducer (1);
- the outputs of said one and said further calculating units (70a, 70b) being operationally connected to a third calculating unit (72);
- the output of said further calculating unit (72) being operationally connected to said adjusting inputs (E_{30}).

8. The apparatus of the claims 5 to 7, **characterized by** the facts that said processor unit (3; 30) comprises a predetermined number of band-pass filters, each predominantly acting in a respective spectral band, said adjusting inputs (E_3 ; E_{30}) being operationally connected to adjusting inputs of said filters.

Patentansprüche

1. Verfahren zum Begrenzen eines an das menschliche Ohr übertragenen Signals in Abhängigkeit von einem ankommenden Schallsignal, **gekennzeichnet durch** die folgenden Schritte:

- Vorsehen einer begrenzenden Hörvorrichtung, die aus einem eingehenden Schallsignal (S) ein Signal (A) erzeugt, das an das menschliche Ohr mit einer steuerbaren Übertragungscharakteristik übertragen wird;
- Speichern eines Schwellenwertes (MAL) in der Vorrichtung;
- Erzeugen eines von der Lautheit ($L(S, P)$; $L_I(S, P_I)$) des übertragenen Signals abhängenden Signals in der Vorrichtung;
- Verringern der Lautheit des an das Ohr übertragenen Signals (A) **durch** Einstellen von Parametern der Übertragungscharakteristik, die die Lautheit (L ; L_I) des an das Ohr übertragenen Signals (A) bestimmen, sobald das von der Lautheit (L ; L_I) des übertragenen Signals (A) abhängende Signal den Schwellenwert (MAL) erreicht.

2. Verfahren nach Anspruch 1, **gekennzeichnet durch** Implementieren der Hörvorrichtung in einem Hörgerät.

3. Verfahren nach Anspruch 1 oder 2, **gekennzeichnet durch** die Schritte, bei denen die Übertragungscharakteristik in Abhängigkeit von der Lautheit, die von einer bestimmten einzelnen Person wahrgenommen wird und in Abhängigkeit von der Lautheit, die von einem Standard wahrgenommen wird, individuell eingestellt wird.

4. Verfahren nach Anspruch 2 oder 3, das ferner die Schritte umfaßt, bei denen:

- die Lautheit ($L_N(S, P_N)$), die durch einen Standard bei einem in die Vorrichtung eingegebenen Schallsignal (S) wahrgenommen wird, berechnet wird;
- die Lautheit ($L_I(S, P_I)$), die von der einzelnen Person bei dem Schallsignal wahrgenommen wird, in Abhängigkeit von der Lautheit des übertragenen Signals (A) berechnet wird;
- eine gewünschte Hörgerät-Übertragungscharakteristik aus den berechneten Lautheiten des Standards bzw.

der einzelnen Person berechnet wird;

- die Übertragungscharakteristik (T) des Hörgeräts in Übereinstimmung mit der gewünschten Übertragungscharakteristik eingestellt wird;
- die Begrenzung durch zusätzliches Einstellen der gewünschten Übertragungscharakteristik in Abhängigkeit von der Lautheit des übertragenen Signals (A) und des Schwellenwertes (MAL) ausgeführt wird.

5. Hörvorrichtung, mit

- einem Eingangs-akustisch/elektrischen Wandler (1), dessen Ausgang wirkverbunden ist mit dem Eingang
- einer Signalprozessoreinheit (3; 30) mit einer steuerbaren Übertragungscharakteristik (T), deren Ausgang wirkverbunden ist mit einem Eingang von
- einem Ausgangs-Wandler (5) für das menschliche Ohr,

dadurch gekennzeichnet, daß vorgesehen sind:

- eine im voraus setzbare Speichereinheit (11; 110);
- eine Recheneinheit (7, 70a), deren Eingang mit dem Ausgang der Prozessoreinheit (3, 30) wirkverbunden ist und die ein Ausgangssignal erzeugt, das von der Lautheit eines Schallsignals abhängt, das durch das Signal am Eingang des Ausgangs-Wandlers (5) repräsentiert wird, wobei
- die Ausgänge der Recheneinheit (7; 70a) bzw. der im voraus setzbaren Einheit (11; 110) mit entsprechenden Eingängen einer Vergleichseinheit (9; 90) wirkverbunden sind;
- der Ausgang der Vergleichseinheit (9; 90) mit Einstelleingängen (E_3 ; E_{30}) für die Charakteristik der Prozessoreinheit (3; 30) wirkverbunden ist.

6. Vorrichtung nach Anspruch 5, **dadurch gekennzeichnet, daß** die Wandler (1, 5) und die Prozessoreinheit (3; 30) Teil eines Hörgeräts sind.

7. Vorrichtung nach Anspruch 6, **gekennzeichnet durch**

- eine zweite Recheneinheit (70b), deren Eingang mit dem Ausgang des Eingangs-Wandlers (1) wirkverbunden ist und die ein Ausgangssignal erzeugt, das eine Standardlautstärke eines an den Eingangs-Wandler (1) eingegebenen Schallsignals repräsentiert;
- wobei die Ausgänge der einen und der weiteren Recheneinheit (70a, 70b) mit einer dritten Recheneinheit (72) wirkverbunden sind;
- und der Ausgang der weiteren Recheneinheit (72) mit den Einstelleingängen (E_{30}) wirkverbunden ist.

8. Vorrichtung nach den Ansprüchen 5 bis 7, **dadurch gekennzeichnet, daß** die Prozessoreinheit (3; 30) eine vorgegebene Anzahl von Bandpaßfiltern umfaßt, wovon jedes hauptsächlich in einem entsprechenden Spektralband wirkt, wobei die Einstelleingänge (E_3 , E_{30}) mit Einstelleingängen der Filter wirkverbunden sind,

Revendications

1. Procédé permettant de limiter un signal transmis à l'oreille humaine, dépendamment d'un signal acoustique entrant, **caractérisé par** les étapes consistant à :

- fournir un appareil auditif limiteur générant à partir d'un signal acoustique entrant (S) un signal (A) transmis à l'oreille humaine avec une caractéristique de transfert réglable ;
- stocker au niveau dudit appareil une valeur de seuil (MAL) ;

EP 0 836 363 B1

- générer au niveau dudit appareil un signal dépendant de la sonie dudit signal transmis ($L(S,P)$; $L_I(S,P_I)$) ;
- réduire la sonie dudit signal transmis (A) à l'oreille en ajustant les paramètres de ladite caractéristique de transfert qui détermine la sonie (L ; L_I) dudit signal (A) transmis à l'oreille dès que ledit signal dépendant de la sonie (L ; L_I) dudit signal transmis (A) atteint ladite valeur de seuil (MAL).

5
2. Procédé selon la revendication 1, **caractérisé par** l'implémentation dudit appareil auditif limiteur dans un appareil de correction auditive.

10
3. Procédé selon la revendication 1 ou 2, **caractérisé par** les étapes consistant à ajuster individuellement ladite caractéristique de transfert en fonction de la sonie telle que perçue par un individu spécifique et de la sonie telle que perçue par un individu standard.

4. Procédé selon la revendication 2 ou 3, comprenant en outre les étapes consistant à :

- 15
- calculer la sonie ($L_N(S,P_N)$), telle que perçue par un individu standard, d'un signal acoustique (S) entré dans ledit appareil ;
 - calculer la sonie ($L_I(S,P_I)$), telle que perçue par l'individu, dudit signal acoustique et dépendant de la sonie dudit signal transmis (A) ;
 - calculer une caractéristique de transfert de correction auditive désirée à partir de ladite sonie calculée du
- 20
- standard et de l'individu ;
 - ajuster ladite caractéristique de transfert (T) de ladite correction auditive en fonction de ladite caractéristique de transfert désirée ;
 - réaliser ladite limitation en ajustant en plus ladite caractéristique de transfert désirée dépendamment de ladite sonie dudit signal transmis (A) et de ladite valeur de seuil (MAL).
- 25

5. Appareil auditif, comprenant :

un transducteur acoustique/électrique d'entrée (1), dont la sortie est connectée fonctionnellement à l'entrée d'une :

- 30
- unité de traitement du signal (3 ; 30) possédant une caractéristique de transfert réglable (T), dont la sortie est connectée fonctionnellement à l'entrée d'un
 - transducteur de sortie (5) destiné à l'oreille humaine,

35 **caractérisé par le fait que** sont fournis :

- une unité de stockage préchargeable (11 ; 110) ;
 - une unité de calcul (7 ; 70a), dont l'entrée est connectée fonctionnellement à la sortie de ladite unité de traitement (3 ; 30), et générant un signal de sortie dépendant de la sonie d'un signal acoustique représenté par ledit signal au niveau de l'entrée dudit transducteur de sortie (5), tenant compte que:
- 40
- les sorties de ladite unité de calcul (7 ; 70a) et de ladite unité préchargeable (11 ; 110) sont connectées fonctionnellement aux entrées respectives d'une unité de comparaison (9 ; 90) ;
 - la sortie de ladite unité de comparaison (9 ; 90) est connectée fonctionnellement aux entrées de réglage (E_3 ; E_{30}) pour ladite caractéristique de ladite unité de traitement (3 ; 30).
- 45

6. Appareil selon la revendication 5, **caractérisé en ce que** lesdits transducteurs (1, 5) et ladite unité de traitement (3 ; 30) font partie d'un appareil de correction auditive.

50 7. Appareil selon la revendication 6, **caractérisé par** :

- une seconde unité de calcul (70b), dont l'entrée est connectée fonctionnellement à la sortie dudit transducteur d'entrée (1), générant un signal de sortie représentant la sonie standard d'un signal acoustique entré dans ledit transducteur d'entrée (1) ;
 - la connexion fonctionnelle des sorties de ladite unité de calcul initiale et desdites unités de calcul supplémentaires (70a, 70b) à une troisième unité de calcul (72) ;
 - la connexion fonctionnelle de la sortie de ladite unité de calcul supplémentaire (72) auxdites entrées de réglage (E_{30}).
- 55

EP 0 836 363 B1

8. Appareil selon les revendications 5 à 7, **caractérisé en ce que** ladite unité de traitement (3 ; 30) comprend un nombre prédéterminé de filtres passe-bande, chacun fonctionnant principalement dans une bande spectrale respective, lesdites entrées de réglage (E_3 ; E_{30}) étant connectées fonctionnellement aux entrées de réglage desdits filtres.

5

10

15

20

25

30

35

40

45

50

55

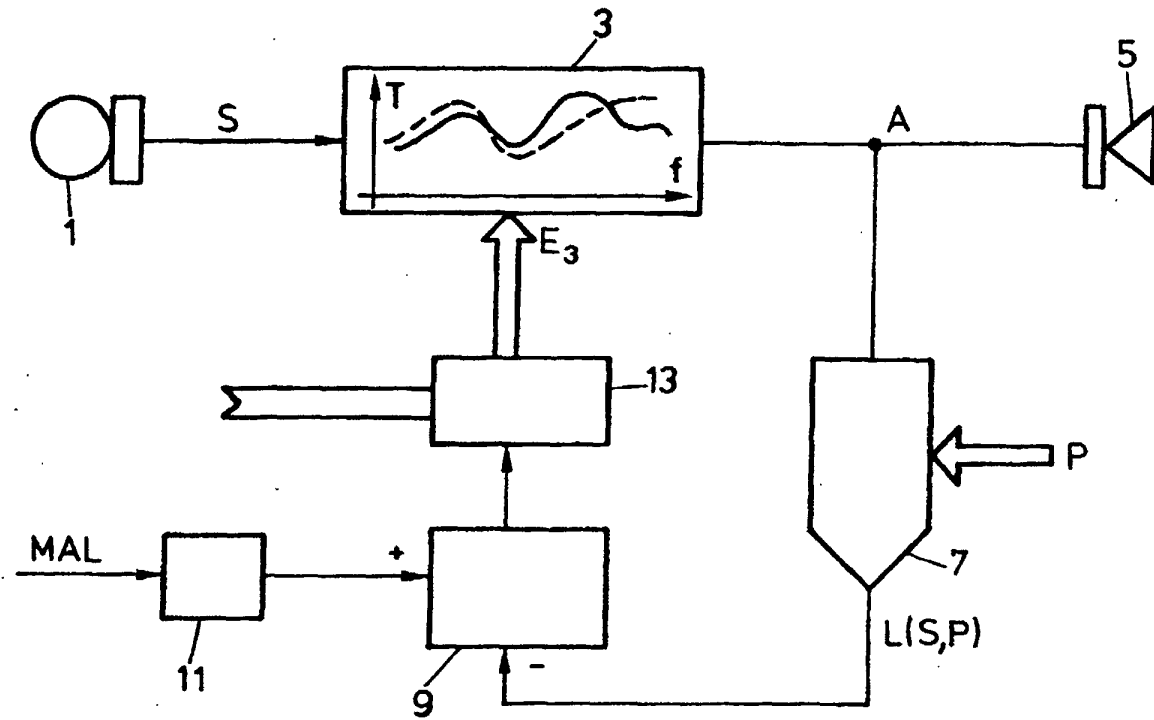

FIG. 1

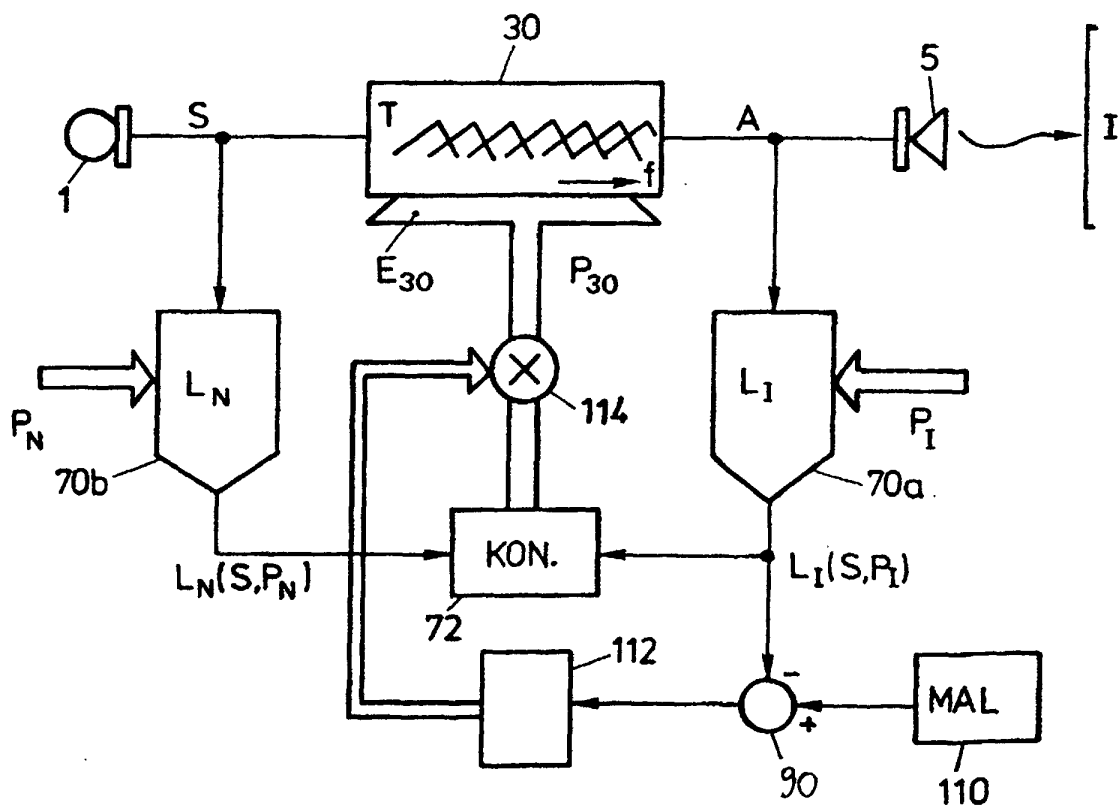

FIG. 2

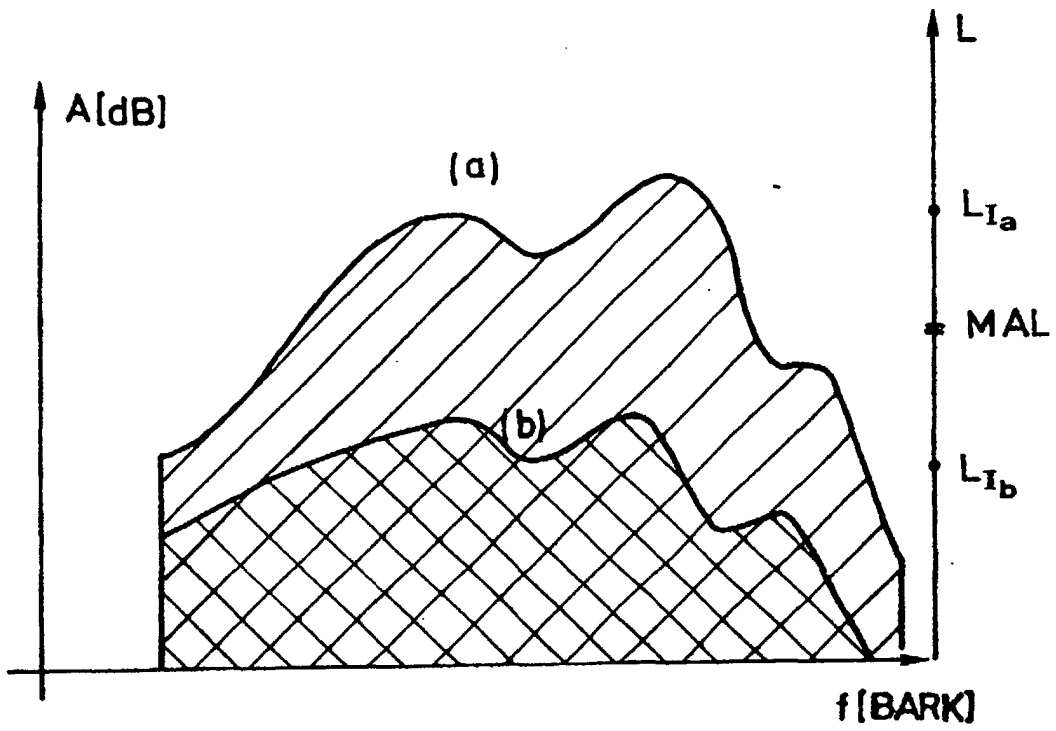

FIG. 3