



(22) **Date de dépôt/Filing Date:** 2010/07/12

(41) **Mise à la disp. pub./Open to Public Insp.:** 2011/01/15

(45) **Date de délivrance/Issue Date:** 2017/07/11

(30) **Priorité/Priority:** 2009/07/15 (IE2009/0538)

(51) **Cl.Int./Int.Cl.** *E06B 3/263* (2006.01),  
*E06B 3/67* (2006.01), *E06B 3/673* (2006.01)

(72) **Inventeur/Inventor:**  
RAWLINGS, DAVID, GB

(73) **Propriétaire/Owner:**  
ARCHITECTURAL & METAL SYSTEMS LIMITED, IE

(74) **Agent:** MARKS & CLERK

(54) **Titre : ELEMENT DE CHASSIS ISOLE**

(54) **Title: INSULATED FRAME MEMBER**

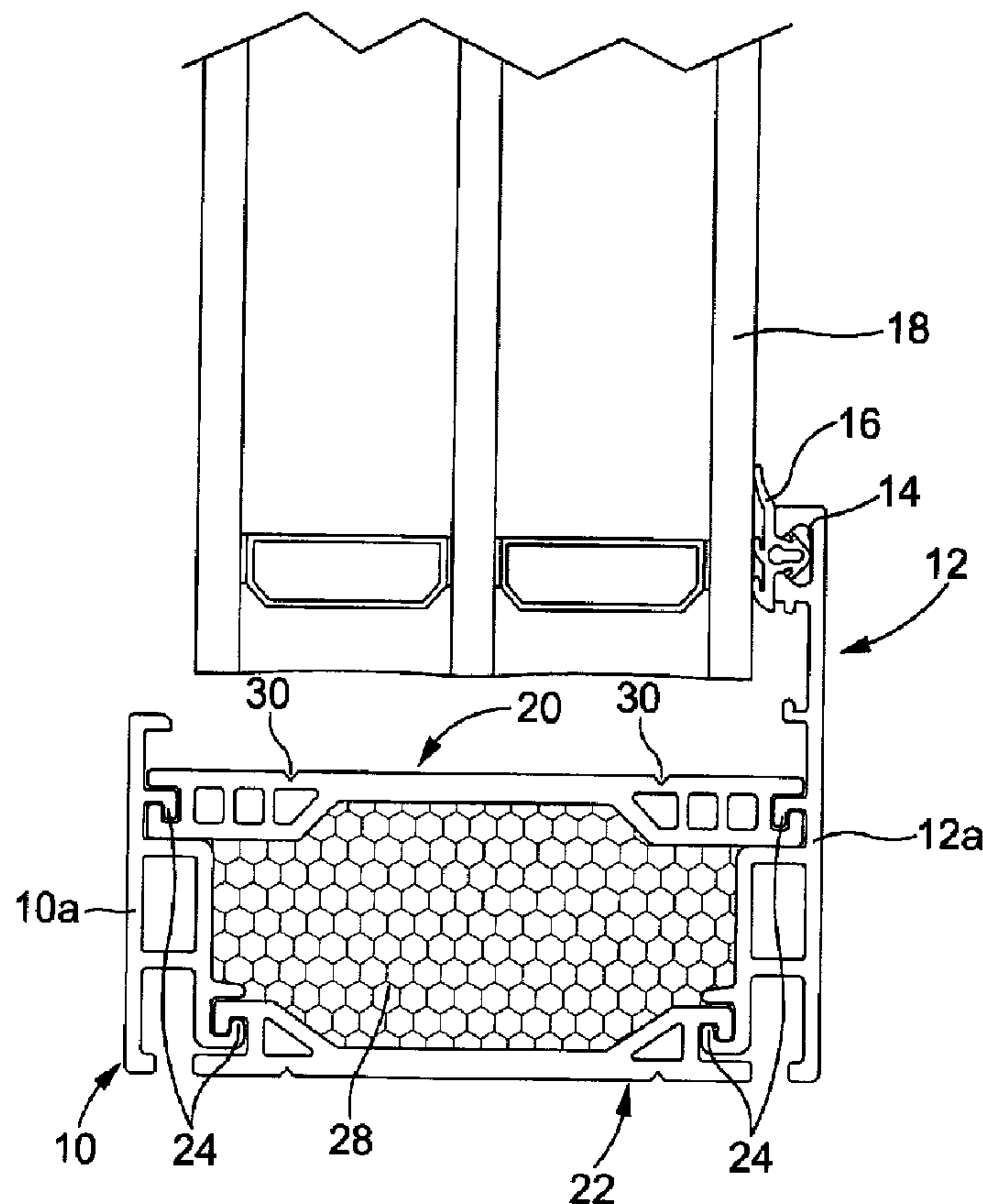

(57) **Abrégé/Abstract:**

An insulated frame member comprising first and second frame components 10, 12 held in a spaced relationship by a first, glazing unit facing connector component 20 and by a second connector component 30, the first and second frame components 10, 12 together defining a void substantially filled with a foamed material 28, wherein the first connector component 20 is of width greater than or equal to the thickness of the glazing unit 18.



**ABSTRACT**

5           An insulated frame member comprising first and second frame components  
10, 12 held in a spaced relationship by a first, glazing unit facing connector  
component 20 and by a second connector component 30, the first and second frame  
components 10, 12 together defining a void substantially filled with a foamed material  
28, wherein the first connector component 20 is of width greater than or equal to the  
10 thickness of the glazing unit 18.

INSULATED FRAME MEMBER

This invention relates to an insulated frame member suitable for use in the formation of a window or door frame or the like. In particular, the invention relates to an insulated frame member of the type including first and second, or inner and outer, elongate metallic frame components and a thermal break interconnecting the frame components.

One type of insulated frame member is described in EP 0007416 and comprises inner and outer extruded aluminium frame components which are interconnected by a pair of plastics material connector components in such a manner as to define an elongate void bounded by the frame components and connector components, the void being filled by a foamed insulating material. During manufacture, the foamed material expands to fill the void and to lock together the frame components and connector components to form a strong, rigid thermal break between the frame components. The frame member is also of good strength and rigidity.

It is desirable to enhance the thermal efficiency of buildings. One area that is important in achieving good thermal efficiency is in the construction of window and door frames. One object of the invention is to provide an insulated frame member suitable for use in meeting the PassivHaus standard, although the invention is suitable for use in other applications.

Although the insulated frame member described above includes a thermal break which may be effective in reducing the conduction of heat between the inner and outer frame components, it is thought to be unsuitable for complying with more up-to-date, stringent requirements and so is unsuitable for reaching the PassivHaus or other modern standards.

According to an aspect of the present invention there is provided an insulated frame member comprising first and second frame components held in a spaced relationship by a first, glazing unit facing connector component and by a second connector component, the first and second frame components together defining a void

substantially filled with a foamed material, wherein the first connector component is of width greater than or equal to the thickness of the glazing unit, and wherein the first and second frame components are provided with L-shaped mounting formation received within corresponding mounting recesses defined by the first connector component to secure the first and second frame components to the first connector component.

As a result, radiation and convection losses from the glazing unit to the frame components may be reduced.

Preferably the first connector component extends from an outer wall of the outer frame component to an inner wall of the inner frame component.

The invention further relates to a door or window frame manufactured from at least one such frame member. Accordingly, according to another aspect of the present invention there is provided a door/window frame comprising at least one insulated frame member as described herein.

According to a further aspect of the present invention there is provided a method of manufacturing an insulated frame member comprising first and second frame components held in a spaced relationship by a first, glazing unit facing connector component and by a second connector component, the first and second frame components together defining a void substantially filled with a foamed material, wherein the first connector component is of width greater than or equal to the thickness of the glazing unit, the first and second frame components being provided with L-shaped mounting formations received within corresponding mounting recesses defined by the first connector component to secure the first and second frame components to the first connector component, the method comprising the steps of assembling the first and second frame components and the first and second connector components to define an elongate void, and injecting a liquid foaming material into the void.

This invention will further be described, by way of example, with reference to the accompanying drawings, in which:

Figure 1 is a sectional view illustrating an insulated frame member in accordance with one embodiment of the invention; and

2a

Figure 2 is an exploded view illustrating parts of the embodiment of Figure 1.

The insulated frame member illustrated in Figures 1 and 2 comprises an inner extruded metallic frame component 10 and an outer extruded metallic frame component 12. Although specific profiles are illustrated in the accompanying drawings, it will be appreciated that the invention is not restricted to these specific profiles, but rather extends to a number of modifications and alterations thereto. The outer frame component 12 includes an outer wall 12a and is shaped to define a recess 14 adapted to receive part of a sealing gasket 16 which seals, in use, against the outer face of a glazing unit 18. In the arrangement illustrated, the glazing unit 18 is of the triple glazed form. However, it will be appreciated that the invention is not restricted to such arrangements and that it is equally applicable to, for example, double-glazed arrangements. The inner frame component 10 includes an inner wall 10a and is adapted to have secured thereto a glazing bead (not shown) which bears against the opposing surface of the glazing unit 18, in use, to secure the glazing unit 18 in position.

The inner and outer frame components 10, 12, are held in a spaced relationship by first and second connector components 20,22. The connector components 20, 22 are each of extruded form, being manufactured from a suitable plastics material. Each of the connector components 20, 22 is shaped to define mounting recesses 24 which, in use, receive corresponding mounting formations 26 of the inner and outer frame components 10, 12.

As shown in Figure 1, it will be appreciated that the assembly of the inner and outer frame components 10, 12 and first and second connector components 20, 22 defines a void of elongate form which, as shown in Figure 1, is filled with a foamed insulating material 28.

It will be appreciated that the provision of the first and second connector components 20, 22 and foamed insulating material 28 connecting the inner and outer frame components 10, 12 to one another provides a good thermal break resisting the conduction of heat energy between the inner and outer frame components 10, 12. The first connector component 20 which faces the glazing unit 18, in use, extends across substantially the full width between the inner wall 10a of the inner frame component 10 and the outer wall 12a of the outer frame component 12, and thus is of width greater than the thickness of the glazing unit 18. As a result, it will be appreciated that most heat energy radiating from the edges of the glazing unit 18 will not be incident upon a relatively good thermal conductor in the form of part of one or other of the frame components 10,12, but rather will be incident on a plastics component of poor thermal conductivity. Radiation losses are thus reduced. By reducing radiation of heat energy from the glazing unit 18 to the frame components 10, 12 it will be appreciated that the thermal efficiency of the insulated frame member is enhanced. Further, convection losses in the space between the frame member and the glazing unit 18 are reduced.

As illustrated, the first connector component 20 is provided with mounting locations 30 in the form of grooves to assist in the correct location of, for example, friction stay tracks or other components. Typically, such components are secured in position using screws. As the first connector component 20 is of double walled form at these locations, including an outer wall 20a and an inner wall 20b, it will be appreciated that such screws are firmly secured in position, the dual wall formation of

that part of the connector component 20 providing additional anchorage for the screws as well as enhancing the stability of the screws.

5 During assembly of the insulated frame member the first and second connector components 20, 22 are secured to the inner frame component 10 by sliding the first and second connector components 20, 22 onto the inner frame component 10 from one end thereof, the formations 26 being introduced into the recesses 24 of the connector components 20, 22. It will be appreciated that the combination of the inner frame component 10 and connector components 20, 22 together defines an open channel into which a thermally insulating foaming material is introduced. The outer frame component 12 is then secured to the first and second connector components 20, 22 by sliding the outer frame component 12 into position in a manner similar to that by which the connector components 20, 22 are secured to the inner frame component 10. Shortly after the outer frame component 12 is secured in position, the thermally insulating foaming material will have commenced foaming and will fill the void defined between the connector components 20, 22 and frame components 10, 12. The foaming and expansion of the thermally insulating foaming material 28 serves to lock together the frame and connector components 10, 12, 20, 22 enhancing the rigidity of the frame member as well as providing a thermal break therebetween.

Alternatively, the frame and connector components 10, 12, 20, 22 may be assembled to form an elongate component defining an elongate void, and liquid foaming material may be injected into the void, for example from an end thereof or through one or more openings formed in one or other of the components, for example through an opening formed at the mid-point of the assembly. Such an arrangement requires the use of less equipment during assembly and lends itself to being supported in a static jig to maintain straightness during foaming, although this may not always be necessary.

30 In the arrangement illustrated, the void is of symmetrical form thus during foaming the foam will tend to apply equal opposite pressures to the aluminium sections, assisting in maintaining straightness with minimal use of jigs.

In use, the frame member can be used in the construction of door or window frames or the like and the invention extends not only to the insulated frame member itself but also to frames manufactured therefrom. If desired, a reverse butt joint can be used, where appropriate, as the connector components 20,22 are shaped in such a manner that the thermal break is substantially symmetrical.

It is envisaged that when used with a triple glazed glazing unit 18, a door or window frame formed using the insulated frame member will have a U value of approximately 0.8 and an A energy rating. Such a frame would therefore be suitable for use in a building satisfying the PassivHaus standard. It will be appreciated, however, that the insulated frame member may be used in other applications.

A number of modifications or alterations may be made to the arrangement described hereinbefore without departing from the scope of the invention.

The embodiments of the invention in which an exclusive property or privilege is claimed are defined as follows:

1. An insulated frame member comprising first and second frame components held in a spaced relationship by a first, glazing unit facing connector component and by a second connector component, the first and second frame components together defining a void substantially filled with a foamed material, wherein the first connector component is of width greater than or equal to the thickness of the glazing unit, and wherein the first and second frame components are provided with L-shaped mounting formations received within corresponding mounting recesses defined by the first connector component to secure the first and second frame components to the first connector component.
2. A frame member according to Claim 1, wherein the first connector component extends from an outer wall of the outer frame component to an inner wall of the inner frame component.
3. A frame member according to Claim 1 or Claim 2, wherein the void is of substantially symmetrical form.
4. A frame member according to any of claims 1 to 3, wherein the first connector component is provided with an elongate location marking.
5. A frame component according to Claim 4, wherein the first connector component is of double walled form adjacent the elongate location marking.
6. A frame component according to Claim 5, wherein the first connector component is provided with a pair of location markings and associated double walled regions.
7. A door/window frame comprising at least one insulated frame member as defined in any one of Claims 1 to 6.
8. A method of manufacturing an insulated frame member comprising first and second frame components held in a spaced relationship by a first, glazing unit facing connector component and by a second connector component, the first and second

frame components together defining a void substantially filled with a foamed material, wherein the first connector component is of width greater than or equal to the thickness of the glazing unit, the first and second frame components being provided with L-shaped mounting formations received within corresponding mounting recesses defined by the first connector component to secure the first and second frame components to the first connector component, the method comprising the steps of assembling the first and second frame components and the first and second connector components to define an elongate void, and injecting a liquid foaming material into the void.

9. A method according to Claim 8, wherein the liquid foaming material is injected into the void from an end thereof.

10. A method according to Claim 8, wherein the liquid foaming material is injected into the void through an opening that opens into the void part way along the length thereof.

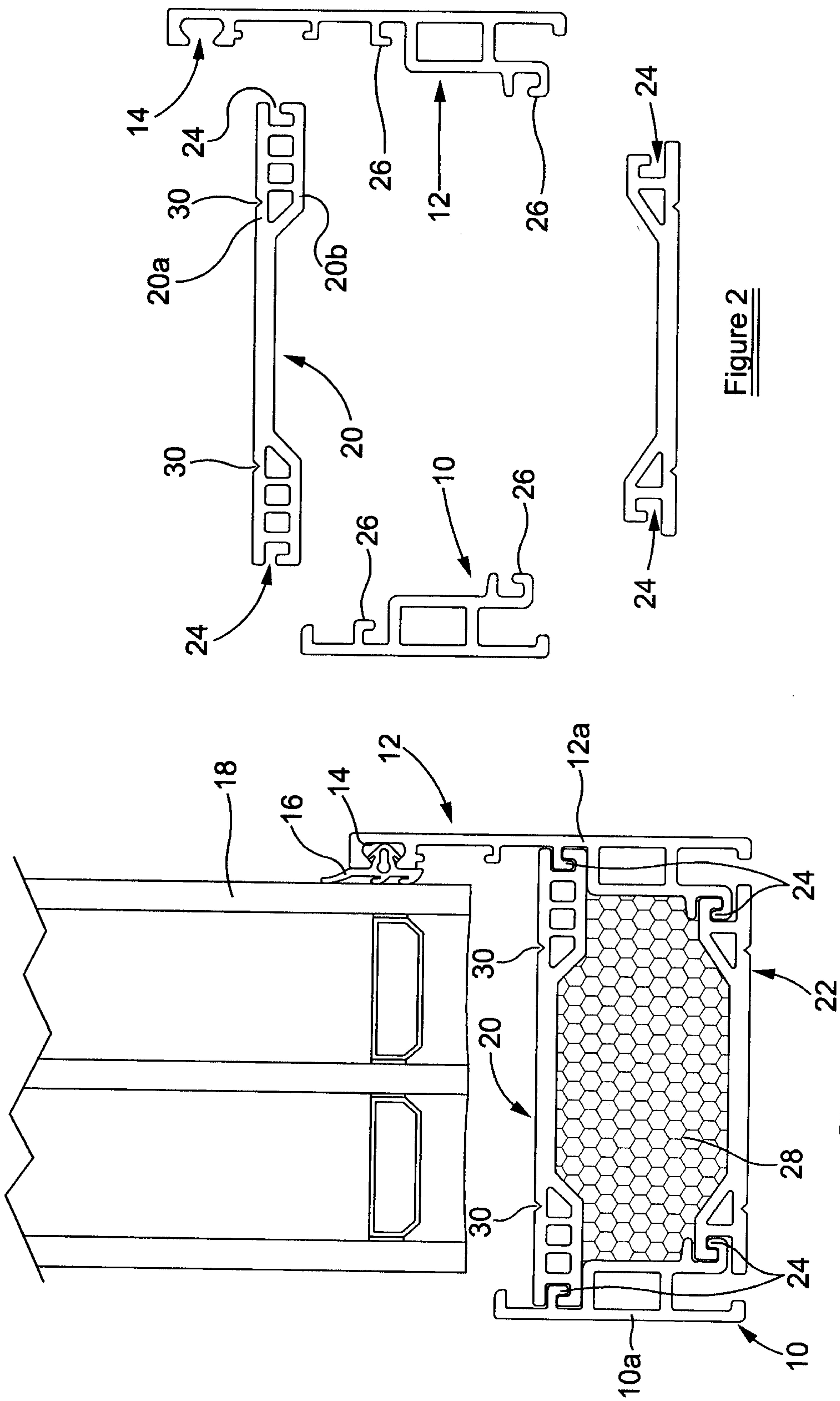

Figure 2

Figure 1

